

University of Zagreb Faculty of Textile Technology



BOOK OF PROCEEDINGS

**13th International
Scientific – Professional Symposium
TEXTILE SCIENCE & ECONOMY**

University of Zagreb Faculty of Textile Technology

**TEXTILE SCIENCE AND
ECONOMY
CHINESE-CROATIAN FORUM
BOOK OF PROCEEDINGS**

13th International Scientific – Professional Symposium

**Innovation, Design and Digitalization in the
Textile and Leather Sector**



18th September 2020, Zagreb, Croatia



ISSN 2787 – 477X

Organized by:

**UNIVERSITY OF ZAGREB
FACULTY OF TEXTILE TECHNOLOGY**

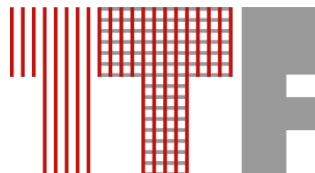

Co-organizer:

College of Textile and Clothing Engineering, Soochow University, China



Partners:

**Confucius Institute at the
University of Zagreb**



**CARNET
Croatian Academic and Research Network**



Patrons:



Republic of Croatia
Ministry of Science and Education



University of Zagreb



Croatian Academy of Engineering



Republic of Croatia
Ministry of Economy, Entrepreneurship and Crafts



BASTE – Balkan Society of Textile Engineers

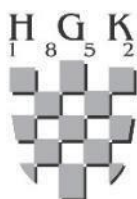

Croatian Chamber of Economy



Croatian Chamber of Trades and Crafts



Croatian Employers' Association



Croatian Engineering Association



HIST – Croatian Association of Textile Engineers



Croatian Leather and Footwear Society

Publisher:

University of Zagreb Faculty of Textile Technology

Editor-in-Chief :

Prof. Slavenka Petrak, Ph.D.

Editors:

Assist. Prof. Emilija Zdraveva, Ph.D., Prof. Budimir Mijović, Ph.D.

TZG Logo/TZG Logo:

Prof. Martinia Ira Glogar, Ph.D.

Contact address:

University of Zagreb
Faculty of Textile Technology
Prilaz baruna Filipovića 28a
CRO-10000 Zagreb
☎: +(385) (1) 3712500
✉: tzg2020@tff.unizg.hr
<http://tzg.tff.unizg.hr/?lang=en>
<http://tzg.tff.unizg.hr/>

Note:

All the papers presented in this publication have been reviewed by international review committee. However the editors and the organizers are not responsible for the contents presented within the papers. All the rights belong to the authors, meaning further publication conditions should be agreed upon with the authors. Upon the Book of the Proceedings publication the authors, so as the other persons or institutions wishing to publish reference or in some other manner use the papers from this publication are kindly requested to explicitly identify prior publication in the Book of the Proceedings TSE 2020.

Scientific Programme Committee

President of the Scientific Committee: Prof. Budimir Mijović, Ph.D. (Croatia)

Vice President of the Scientific Committee: Prof. Ke-Qin Zhang, Ph.D. (PR China)

Members of the Scientific Committee:

Prof. Emeritus Ana-Marija Grancarić, Ph.D. (Croatia, University of Zagreb Faculty of Textile Technology)
Prof. Mirela Blaga, Ph.D. (Romania, Gheorghe Asachi Technical University of Iasi)
Prof. Omar Cherkaoui, Ph.D. (Morocco, École Supérieure des Industries du Textile et de l'Habillement (ESITH))
Prof. Snježana Firšt Rogale, Ph.D. (Croatia, University of Zagreb Faculty of Textile Technology)
Prof. Jelka Geršak, Ph.D. (Slovenia, Univerza v Mariboru, Fakulteta za strojništvo)
Prof. Katarzyna Grabowska, Ph.D. (Poland, Lodz University of Technology, Faculty of Material Technologies and Textile Design)
Prof. Atif Hodžić, Ph.D. (Bosnia and Herzegovina, Technical Faculty of the University of Bihać)
Prof. Paul Kiekens, Ph.D. (Belgium, Ghent University, Centre for Textile Science and Engineering)
Prof. Shunichi Kobayashi, Ph.D. (Japan, Shinshu University, Faculty of Textile Science and Technology)
Prof. Vladan Končar, Ph.D. (France, Ecole Nationale Supérieure des Arts et Industries Textiles · GEMTEX)
Prof. Victor Kuzmichev, Ph.D. (Russia, Ivanovo State Polytechnic University · Textile Institute)
Prof. Yi Li, Ph.D. (Great Britain, University of Manchester, Department of Materials, School of Natural Sciences)
Prof. Yu Bin, Ph.D. (PR China, Zhejiang University)
Prof. Rimvydas Milašius, Ph.D. (Lithuania, Kaunas University of Technology · Department of Materials Engineering)
Prof. Gordana Pavlović, Ph.D. (Croatia, University of Zagreb Faculty of Textile Technology)
Prof. Vasilije Petrović, Ph.D. (Serbia, University of Novi Sad, Technical faculty "Mihajlo Pupin" Zrenjanin)
Assoc. Prof. Iva Rezić, Ph.D. Ph.D. (Croatia, University of Zagreb Faculty of Textile Technology)
Prof. Xianyi Zeng, Ph.D. (France, Ecole Nationale Supérieure des Arts et Industries Textiles · GEMTEX)
Prof. Xungai Wang, Ph.D. (Australia, Deakin University, Institute for Frontier Materials)
Assoc. Prof. Vien Cheung, Ph.D. (Great Britain, University of Leeds, Faculty Of Arts, Humanities And Cultures)

Organizing Committee

President of the Organizing Committee: Prof. Slavenka Petrak, Ph.D.

Vice President of the Organizing Committee: Prof. Darko Ujević, Ph.D.

Members of the Organizing Committee:

Prof. Martinia Ira Glogar, Ph.D.
Prof. Željko Penava, Ph.D.
Assoc. Prof. Sanja Ercegović Ražić, Ph.D.
Assoc. Prof. Art. Koraljka Kovač Dugandžić
Assist. Prof. Ivana Schwarz, Ph.D.
Assist. Prof. Blaženka Brlobašić Šajatović, Ph.D.
Assist. Prof. Lea Botteri, Ph.D.
Assist. Prof. Art. Marin Sovar
Assist. Prof. Emilija Zdraveva, Ph.D.
Maja Mahnić Naglič, mag. ing. techn. text.
Željka Pavlović, mag. ing. techn. text.
Ivan Beritić, mag. ing. techn. text.
Srđan Cvetanović

Reviewers:

Aminoddin Haji, Ana-Marija Grancarić, Andrej Demšar, Anita Tarbuk, Antonela Curteza, Atif Hodžić, Blaženka Brlobašić Šajatović, Bosiljka Šaravanja, Budimir Mijović, Darko Ujević, Dejla Ramić, Dragan Đorđević, Dragana Kopitar, Edit Csanák, Emilija Zdraveva, Emriye Perrin Akçakoca Kumbasar, Fatma Kalaoglu, Goran Čubrić, Hüseyin Kadoglu, Irena Šabarić, Irfan Hošić, Ivana Salopek Čubrić, Jelka Geršak, Katarina Nina Simončič, Krste Dimitrovski, Lubos Hes, Maja Mahnić Naglič, Marija Gorjanc, Mario Cetina, Martin Dadić, Martinia Ira Glogar, Nenad Ćirković, Olivera Šauperl, Omar Cherkaoui, Renata Hrzenjak, Riza Atav, Sandra Flinčec Grgac, Slavenka Petrak, Snežana Stanković, Snježana Brnada, Snježana Firšt Rogale, Sonja Šterman, Suzana Đorđević, Tanja Pušić, Tatjana Rijavec, Vasilije Petrović, Vesna Marija Potočić Matković, Vien Cheung, Zbigniew Draczyński, Zenun Skenderi

Editor's word

13th scientific-professional symposium Textile Science and Economy 2020 – TSE 2020, which was postponed due to the pandemic caused by the COVID-19 virus, was held on September 18, 2020, organized by the University of Zagreb Faculty of Textile Technology. Given the unfavourable epidemiological situation in many countries around the world, including the Republic of Croatia, the Symposium was held as a video conference.

This year's symposium is organized as a CHINESE-CROATIAN FORUM, encouraged by the established scientific and bilateral cooperation between the scientists from the University of Zagreb Faculty of Textile Technology and the Zhejiang University as well the College of Textile and Clothing Engineering, Soochow University in China. In this sense, we have further chosen the Confucius institute at the University of Zagreb as a partner in the organization of the Symposium. The main role of the Confucius institute in Croatia is to promote the Chinese language and culture, thus to strengthen the economic bond between the Republic of Croatia and the People's Republic of China. The technical support for the organization of the videoconference was provided by the Croatian Academic and Research Network. On this occasion, I would like to thank our partners for their contribution. This year's symposium was held under the auspices of the umbrella state institutions, one international and other Croatian associations, important for the Textile and Leather sector, which I would also like to thank. I want to particularly thank all the distinguished guests and senior government officials for their presence, welcome speeches and their support.

The main topic of the symposium was "Innovation, Design and Digitization in the Textile and Leather Sector", which is also promoted by the strategies of the European Union and has also opened the possibility of presenting the latest scientific and technological achievements, the potential for their commercialization and development trends through an interdisciplinary approach at the global level, as directions for future Textile and Leather sector's development. The Conference was held simultaneously within three virtual rooms:

VIRTUAL ROOM 1 - a central room where invited lectures were held.

VIRTUAL ROOM 2 - a room where several national scientific projects by our esteemed professors were presented, as well as economic block, where presentations of company representatives and promotional activities of companies from the Textile and Leather sector were held. Some of the former students of the University of Zagreb Faculty of Textile Technology, also presented themselves as successful young entrepreneurs.

VIRTUAL ROOM 3 - PhD students' room, where both students' presentations from the University of Zagreb Faculty of Textile Technology and other participating Institutions were held.

14 invited lectures were held by eminent scientific and professional experts from seven countries, who have given lectures on nowadays' hot scientific research topics, on the economic sector challenges during the global pandemic and some guidelines for a possible growth. The same are based on the implementation of innovations in the development processes, important for the economy, digitalization of business processes, networking as well as challenges and opportunities of the digital age, in terms of global economy. The economy of the 21st century is facing new challenges in the field of entire business digital transformation, as well as product development, based on innovation. The digital transformation implies a thorough and fast transformation of the business, processes, capabilities and models, with the aim to fully exploit the possibilities of digital technologies and their impact on the economy, but also on the society as a whole. Within this respect, special attention was given to China, as the world's largest market and economic superpower of the 21st century. I would like to thank them all, as well as all other participant in two other virtual rooms. My special thanks go also to all sponsors and donation partners, which have supported the realization of the video conference in this extremely difficult time of the economy sector.

Numerous scientists and experts from the international scientific community and the Republic of Croatia, as well as prominent experts, have contributed to the symposium by submitting their

scientific, review or professional papers. We have accepted a total of 55 papers, out of which 21 are submitted by the PhD students, enrolled in the doctoral study Textile Science and Technology at the University of Zagreb Faculty of Textile Technology. Among those, several are coming from the Technical University of Lodz in Poland and the University of Zagreb Faculty of Electrical Engineering and Computing. In this sense, Symposium accompanies the edition of the Book of Proceedings, as well as the Book of Abstracts in the online edition with open access. I would like to thank all the authors and co-authors of the papers for their contribution, as well as the Scientific Committee and our distinguished scientists from the International Review Committee, who have contributed with their expertise, to the Proceedings compilation of scientific, review and professional papers, covering relevant research topics.

Given that this year's Symposium was held as an international video conference for the first time, in addition to the numerous participants who actively participated in the symposium realization within the virtual rooms, public monitoring of the video conference was provided via a live stream through TSE 2020 official website, TTF official website and You Tube channels. The video conference was followed by more than 700 participants from a number of countries around the world, from the international academic community, the economic sector, state institutions and participants from the field of vocational education, Textile and leather sector.

I would like to thank all the participants for their presence and I do hope it was beneficial for them. I also hope that this event will positively contribute to the visibility of the entire activity of the University of Zagreb Faculty of Textile Technology in the international academic community, as well as in the economic sector. I would sincerely like to thank the Faculty management for their trust, support and help and finally, my great thanks to all my dear colleagues from the organizing committee for all the support, enthusiasm and effort invested in the organization of the first international video conference organized by the University of Zagreb Faculty of Textile Technology.

Zagreb, September 18th, 2020.

Proceedings Editor-in-Chief:



Prof. Slavenka Petrak, Ph.D.



CONTENTS

ORIGINAL SCIENTIFIC PAPERS:**A - High performance fibres, yarns and 3D composites**

Antoneta TOMLJENOVIĆ; Zlatko VRLJIČAK; Juro ŽIVIČNJAK; Mateja VLAINIĆ & Ivana BONIĆ Evaluation of usage quality of weft knitted fabrics made of viscose fibres	1
Ivana SALOPEK ČUBRIĆ & Antonija PETROV The influence of aging on tensile properties of knotted yarns	7
Ivana SALOPEK ČUBRIĆ & Martina CVETKO Characterization of yarns used to maintain dental health	11

D - Advanced technologies and processes – application in textiles, clothing, leather and footwear production

Sanja ERCEGOVIĆ RAŽIĆ; Jadranka AKALOVIĆ; Tomislav IVANKOVIĆ; Jelena PERAN & Katarina IŠTEF Plasma pre-treatments improves antimicrobial properties of bovine splitted leather	15
Suzana ĐORĐEVIĆ; Dragan ĐORĐEVIĆ; Stana KOVAČEVIĆ & Ivana SCHWARZ Synthetized corn starch - environmentally acceptable for cotton warp sizing	21

E - Medical and protective textiles, clothing and footwear

Uwe REISCHL & Budimir MIJOVIĆ Changes in fabric elasticity in response to sterilization with ozone	27
---	----

F - Advanced processes of finishing, care, dyeing and printing of textiles and leather

Anita TARBUK; Dragan ĐORĐEVIĆ; Sandra FLINČEC GRGAC; Marija KODRIĆ; Eva Magovac & Ivana ČORAK The influence of lipase surface modification to polyester crystallinity and absorbility	33
Dragan ĐORĐEVIĆ; Anita TARBUK; Marija, KODRIĆ; Radica NIČIĆ; Nenad ĆIRKOVIĆ & Nemanja VUČKOVIĆ Bioprocessing of polyester knitwear by papain enzymes	39
Ivana ČORAK; Tihana DEKANIĆ; Petra KAŠAJ & Anita TARBUK The optimization of di(cyanstyryl) derivative application to polyester fabric and its blend	45
Sandra FLINČEC GRGAC; Tea-Dora BIRUŠ; Anita TARBUK; Rajna MALINAR & Zbigniew DRACZYŃSKI The influence of maleic acid concentration on the binding of chitosan with cotton cellulose	51
Tanja PUŠIĆ; Bosiljka ŠARAVANJA; Krešimir MALARIĆ & Silvia BEŠLIĆ Impact of wet treatments on shield effectiveness of nickel/copper coated fabric	56

G - Analysis and methods of measurement in textiles, clothing and footwear

Iva REZIĆ; Lela PINTARIĆ; Mislav MAJDAK & Maja SOMOGYI ŠKOC Thin layer chromatographical determination of metals used as antibacterial components on biodegradable polymers	62
Željko PENAVAL; Diana ŠIMIĆ PENAVAL & Maja BANIČEK Prediction of boundary elongation force of fabric in elastic area by lethersich's rheological model	68

I - Textile design, fashion and functional clothing design, footwear and accessories design

Danijela JEMO; Sandra FLINČEC GRGAC; Danijela ERAK & Agneza ŠTAJER
Charleston beaded dress: preliminary analysis..... 75

Katarina ZMEŠKAL & Slavenka PETRAK
Design and computer pattern making of a collection of individualized medical uniforms..... 80

J - Digitalization of textile, fashion and footwear industry

Ana-Marija GUŠA; Slavenka PETRAK & Maja MAHNIĆ NAGLIĆ
Elements of traditional China in computer design of author's fashion clothing collection..... 86

Elena TOMOVSKA
Influence of social media on fashion innovativeness..... 92

K - Anthropometric body measurements – modern measurement systems and applications

Darko UJEVIĆ; Blaženka BRLOBAŠIĆ ŠAJATOVIĆ; Yu BIN & Zhu FEICHAO
Comparation of Croatian and Chinese clothing size system with reference to characteristic body proportions 98

N - Ecology and sustainable development, waste problems in the textile and leather sector

Ana Maria BOČAK; Ružica BRUNŠEK; Anita TARBUK & Ana SUTLOVIĆ
Linen fabric dyed with flavonoid compounds extracted from waste onion skin..... 104

REVIEW PAPERS:**H - Thermophysiological properties and comfort of textiles, clothing and footwear**

Snežana STANKOVIĆ; Mateja BIZJAK; Dušan POPOVIĆ & Goran POPARIĆ
Potential of hemp textile fabrics in terms of comfort 111

J - Digitalization of textile, fashion and footwear industry

Edit CSANÁK
AI for fashion..... 117

L - Innovative clothing engineering – wearable technology, devices and electronics

Snježana FIRŠT ROGALE, Dubravko ROGALE & Daniel ČASAR VELIČAN
E-clothing for stage performances..... 124

M - Industry 4.0

Vasilije PETROVIĆ; Gordan SMUĐ; Marija PEŠIĆ; Marija PETROVIĆ; Jovana STEPANOVIĆ & Anita MILOSAVLJEVIĆ
The fourth industrial revolution in clothing production..... 132

Q - Modern educational methods of learning and teaching

Ivana SALOPEK ČUBRIĆ; Ines KATIĆ KRIŽMANČIĆ; Branka TOMIĆ Creative thinking techniques - strategies for successful doctoral research	139
---	-----

PROFESSIONAL PAPERS:**G - Analysis and methods of measurement in textiles, clothing and footwear**

Željko PENAVALA; Diana ŠIMIĆ PENAVALA & Tea JOVANOVIĆ Comparison of anisotropic properties of woven fabrics and knitted fabrics subjected to tensile load	146
--	-----

I - Textile design, fashion and functional clothing design, footwear and accessories design

Branka TOMIĆ; Ivana SCHWARZ & Koraljka KOVAČ DUGANDŽIĆ Reflecting on tradition through the creation of contemporary textile object in the old-fashioned way	152
Dejla RAMIĆ; Belma GUTLIĆ A creative consideration of rainwear	158
Emma IVANKOVIĆ; Katarina Nina SIMONČIĆ; Irena ŠABARIĆ Study case - reconstruction of men's clothing from the second half of the 16 th century	164
Irena ŠABARIĆ; Franka KARIN & Doriana DUIĆ The revival of gold thread embroidery in the concept of slow fashion	170
Ivan MIHALJEVIĆ; Blaženka BRLOBAŠIĆ ŠAJATOVIĆ & Maja MAHNIĆ NAGLIĆ The influence of Chinese folk costume on the design of women's business clothing	175
Sara ŠUMANOVIĆ & Renata HRŽENJAK Construction of a modern women's costume inspired by men's fashion	182
Valentina FERENČAK; Tena OMEROVIĆ & Vesna Marija POTOČIĆ MATKOVIĆ Designing a knitwear collection based on motifs and symbols of dynastic China textiles	188

M - Industry 4.0

Ivan KATIĆ & Slavenka PETRAK Leather furniture cutting room - Industry 4.0 with Lectra Versalis	194
--	-----

The Doctoral Students' Section (DSS)**ORIGINAL SCIENTIFIC PAPERS:****A - High performance fibres, yarns and 3D composites**

Tea JOVANOVIĆ; Željka PAVLOVIĆ; Miloš LOZO & Zlatko VRLJIČAK Knitting short socks with siro and modal yarns	202
--	-----

B - Novel materials: biomaterials, nanomaterials and smart materials

- Lela MARTINAGA; Sara ČAČKO; Stella HAMILTON; Ana VRSALović PRESEČKI & Iva REZIĆ
Environmentally acceptable synthesis of nanoparticles for their potential use as textile coatings..... 208
- Zorana KOVAČEVIĆ, Sandra BISCHOF, Mizi FAN
Nanobiocomposites reinforced with Spanish broom (*Spartium junceum* L.) fibres 214

D - Advanced technologies and processes – application in textiles, clothing, leather and footwear production

- Ivana VITLOV; Ivana SCHWARZ; Stana KOVAČEVIĆ & Snježana BRNADA
Properties of PA/cotton yarns enhanced by the sizing process 220
- Snježana KIRIN & Anica HURSA ŠAJATOVIĆ
Research on workload in the technological sewing process using ANSI Z 365 standards.....226

E - Medical and protective textiles, clothing and footwear

- Franka ŽUVELA BOŠNJAK; Sandra FLINČEC GRGAC & Suzana MIHANOVIĆ
Application of microscale combustion calorimeter to characterize protective properties of bovine leather 232

F - Advanced processes of finishing, care, dyeing and printing of textiles and leather

- César Israel HERNÁNDEZ VÁZQUEZ; Zbigniew DRACZYŃSKI & Grzegorz SZPARAGA
Results of chitosan fibres formation by wet spinning method in a high-efficiency laboratory set.....239
- Dominik Sikorski & Zbigniew Draczyński
Assessment of the degree of attachment of acid groups to chitosan fibers 245
- Ksenija VIŠIĆ & Tanja PUŠIĆ
The influence physico-chemical properties of anti-redeposition agents on the zeta potential of washed cotton fabrics 248
- Nina TARZYŃSKA & Zbigniew DRACZYŃSKI
Impact of the aging process on sodium alginate solutions with the addition of low molecular weight ionic compounds..... 252

G - Analysis and methods of measurement in textiles, clothing and footwear

- Katia GRGIĆ & Tanja PUŠIĆ
Adsorption of cetylpyridinium chloride on standard polyester fabric in the electrokinetic analyzer. 257
- Kristina ŠIMIĆ; Ivo SOLJAČIĆ & Tihana PETROVIĆ LEŠ
Analysis of metal threads in the historical Croatian textile from 17th to 20th century.....261
- Mateo Miguel KODRIČ KESOVIA & Željko PENAVALA
Applying image analysis for measuring the density of historical textiles 265
- Rajna MALINAR & Sandra FLINČEC GRGAC
Textile dust generation from cotton and cotton/polyester blend fabrics 271
- Željka PAVLOVIĆ & Zlatko VRLJIČAK
Modern knitted fabrics for underwear.....275

H - Thermophysiological properties and comfort of textiles, clothing and footwear

Nikolina JUKL; Snježana FIRŠT ROGALE & Dubravko ROGALE Thermal insulation properties of the protective vest tested on a thermal manikin in static mode	282
---	-----

K - Anthropometric body measurements – modern measurement systems and applications

David BOJANIĆ; Kristijan BARTOL; Tomislav PETKOVIĆ; Tomislav PRIBANIĆ A review of rigid 3D registration methods	286
Maja MAHNIĆ NAGLIĆ & Slavenka PETRAK Development of a female body types classification method.....	297
Marija NAKIĆ & Slavica BOGOVIĆ Designing of functional garment item for people with disabilities	303

PROFESSIONAL PAPERS:**F - Advanced processes of finishing, care, dyeing and printing of textiles and leather**

Anna BEDNAROWICZ & Zbigniew DRACZYŃSKI Modification of cotton fabric with cross-linked and grafted gelatine	309
--	-----

I - Textile design, fashion and functional clothing design, footwear and accessories design

Ines KATIĆ KRIŽMANČIĆ; Koraljka KOVAČ DUGANDŽIĆ & Martinia Ira GLOGAR Innovation of bauhaus textile designers as inspiration for contemporary textile design	315
---	-----

N - Ecology and sustainable development, waste problems in the textile and leather sector

Anja LUDAŠ; Suzana VIDEK & Ana SUTLOVIĆ Agro-waste and easily renewable plants as sources for natural silk dyes	321
--	-----

Presentation of Selected Scientific Projects of the University of Zagreb Faculty of Textile Technology

Dubravko, ROGALE Development and thermal properties of intelligent clothing (IP-2018-01-6363)	328
Zenun, SKENDERI Comfort and antimicrobial properties of textiles and footwear (IP-2016-06-5278)	329
Budimir, MIJOVIĆ Custom Tailored Fibrous Scaffold Prototype for Tissue Cells Culture via Combined Electrospinning (IP-2016-06-6878).....	330

Partners

CONFUCIUS INSTITUTE AT THE UNIVERSITY OF ZAGREB 萨格勒布大学孔子学院	332
---	-----

CARNET - The Croatian Academic and Research Network333

Sponsors and donors

Sponsors and donors 335

Hrvatski klaster konkurentnosti industrije tekstila, kože i obuće
Croatian cluster of textile, leather goods and footwear industry competitiveness

Čateks d.d. Čakovec

Tekstilpromet d.d.

Hrvatska obrtnička komora
Croatian chamber of trades and crafts

Obrtnička komora Zagreb
Zagreb chamber of trades and crafts

Tekstilpromet d.d.

Jelen Professional d.o.o.

Tekstilna galanterija Panić

Coca Cola HBC Hrvatska d.o.o.

Vinarija Šafran

Appendix

Symposium program



AUTHOR INDEX

Author Indeks

A		F	
Akalović, Jadranka	15	Fan, Mizi	214
B		Feichao, Zhu	98
Baniček, Maja	68	Ferenčak, Valentina	188
Bartol, Kristijan	286	Firšt Rogale, Snježana	124, 282
Bednarowicz, Anna	309	Flinčec Grgac, Sandra	33, 51, 75, 232, 271
Bešlić, Silvia	56	G	
Bin, Yu	98	Glogar, Martinia Ira	315
Biruš, Tea-Dora	51	Grgić, Katia	257
Bischof, Sandra	214	Guša, Ana-Marija	86
Bizjak, Mateja	111	Gutlić, Belma	158
Bočak, Ana Maria	104	H	
Bogović, Slavica	303	Hamilton, Stella	208
Bojanić, David	286	Hernández Vázquez,	239
Bonić, Ivana	1	César Israel	182
Brlobašić Šajatović,	98, 175	Hrženjak, Renata	226
Blaženka		Hursa Šajatović, Anica	
Brnada, Snježana	220	I	
Brunšek, Ružica	104	Ištef, Katarina	15
C		Ivanković, Emma	164
Csanák, Edit	117	Ivanković, Tomislav	15
Cvetko, Martina	11	J	
Č		Jemo, Danijela	75
Čačko, Sara	208	Jovanović, Tea	146, 202
Časar Veličan, Daniel	124	Jukl, Nikolina	282
Čorak, Ivana	33, 45	K	
Ć		Karin, Franka	170
Ćirković, Nenad	39	Kašaj, Petra	45
D		Katić, Ivan	194
Dekanić, Tihana	45	Katić Križmančić, Ines	139, 315
Draczyński, Zbigniew	51, 239, 245, 252, 309	Kirin, Snježana	226
Duić, Doriana	170	Kodrić Kesovia, Mateo Miguel	265
Đ		Kodrić, Marija	33, 39
Đorđević, Dragan	21, 33, 39	Kovac Dugandžić,	152, 315
Đorđević, Suzana	21	Koraljka	
E		Kovačević, Stana	21, 220
Erak, Danijela	75	Kovačević, Zorana	214
Ercegović Ražić, Sanja	15		

L		S	
Lozo, Miloš	202	Salopek Čubrić, Ivana	7, 11, 139
Ludaš, Anja	321	Schwarz, Ivana	21, 152, 220
M		Sikorski, Dominik	245
Magovac, Eva	33	Simončić, Nina Katarina	164
Mahnić Naglič, Maja	86, 75, 297	Smuđ Gordan	132
Majdak, Mislav	62	Soljačić, Ivo	261
Malarić, Krešimir	56	Somogyi Škoc, Maja	62
Malinar, Rajna	51, 271	Stanković, Snežana	111
Martinaga, Lela	62, 208	Stepanović, Jovana	132
Mihaljević, Ivan	175	Sutlović, Ana	104, 321
Mihanović, Suzana	232	Szparaga, Grzegorz	239
Mijović Budimir	27	Š	
Milosavljević, Anita	132	Šabarić, Irena	164, 170
N		Šaravanja, Bosiljka	56
Nakić, Marija	303	Šimić, Kristina	261
Ničić, Radica	39	Šimić Penava, Diana	68, 146
O		Štajer, Agneza	75
Omerović, Tena	188	Šumanović, Sara	182
P		T	
Pavlović, Željka	68, 202, 275	Tarbuk, Anita	33, 39, 45, 51, 104
Penava, Željko	68, 146, 265	Tarzyńska, Nina	252
Peran, Jelena	15	Tomić, Branka	139, 152
Pešić, Marija	132	Tomljenović, Antoneta	1
Petković, Tomislav	286	Tomovska, Elena	92
Petrak, Slavenka	80, 86, 194, 297	U	
Petrov, Antonija	7	Ujević, Darko	98
Petrović Marija	132	V	
Petrović, Vasilije	132	Videk, Suzana	321
Petrović Leš Tihana	261	Višić, Ksenija	248
Poparić Goran	111	Vitlov, Ivana	220
Popović, Dušan	111	Vlainić, Mateja	1
Potočić Matković, Vesna	188	Vrljičak, Zlatko	1, 202, 275
Marija		Vrsalović Presečki, Ana	208
Pribanić, Tomislav	286	Vučković, Nemanja	39
Pušić, Tanja	56, 248, 257	Z	
R		Zmeškal, Katarina	80
Ramić, Dejlja	158	Ž	
Reischl, Uwe	27	Živičnjak, Juro	1
Rezić, Iva	62, 208	Žuvela Bošnjak, Franka	232
Rogale, Dubravko	124, 282		



ORIGINAL SCIENTIFIC PAPERS

EVALUATION OF USAGE QUALITY OF WEFT KNITTED FABRICS MADE OF VISCOSE FIBRES

Antoneta TOMLJENović; Zlatko VRLJIČAK; Juro ŽIVIČNJAK; Mateja VLAINIĆ
& Ivana BONIĆ

Abstract: Knitwear that are worn in direct contact with the skin, are often made of man-made artificial fibres from cellulose. In this paper four different circular weft double jersey knitted fabrics made of standard single viscose ring spun yarn, viscose rotor and air-jet spun yarns, and SiroSpun® ring two-play yarn of the same linear density were used. The usage quality of raw and finished knitted fabrics were evaluated and their applicability assessed. Along with the basic characterization of yarns, testing of mass per unit area, thickness and number of wales and courses per unit length of knitted fabrics were carried out. Knitwear usage quality were evaluated by determination of breaking strength and elongation, dimensional change and spirality after laundering, permeability of fabrics to air, their propensity to surface pilling and abrasion resistance, all according to the standardized test methods.

Keywords: viscose knitwear, double jersey, usage quality, textile testing

1. Introduction

The number of European standards related to testing and characterization of knitted fabrics are low [1]. Therefore, it is necessary to expand the research in the field of their usage quality evaluation. Knitwear that are worn in direct contact with the skin, are often made of man-made artificial fibres from cellulose (eg. viscose, modal or lyocell) which provide silky touch, better hydrophilicity and exceptional contact comfort. Knitted fabrics were usually made of single spun yarns produced by conventional ring spinning system. More recently in application were also spun yarns made by unconventional SiroSpun® ring, rotor and air-jet spinning systems. Different spinning systems provide spun yarns of different structure and properties [2].

In this paper four different circular weft double jersey knitted fabrics made of standard single viscose ring spun yarn, viscose rotor and air-jet spun yarns, and SiroSpun® ring two-play yarn of the same linear density were used. The usage quality of raw and finished knitted fabrics were evaluated and their applicability assessed. Along with the basic characterization of yarns, testing of mass per unit area, thickness and number of wales and courses per unit length of knitted fabrics were carried out. Knitwear usage quality were evaluated by determination of breaking strength and elongation, dimensional change and spirality after laundering, permeability of fabrics to air, their propensity to surface pilling and abrasion resistance, all according to the standardized test methods.

2. Materials and methods used

Four different yarns of the same linear density (20 tex) chosen for the knitting purpose were used: standard single viscose ring spun yarn as a reference; single rotor spun and air-jet yarns, and SiroSpun® ring two-play yarn, all made of bright staple viscose fibres of linear density of 1.3 dtex and length of 38/40 mm. Properties of the yarn used are shown in the Table 1.

Table 1: Properties of viscose yarns used

Yarn/fibre type	Linear density (tex)	Breaking strength (cN)	Breaking elongation (%)	Tenacity (cN/tex)
1 ring/viscose	20	312	13.8	15.6
2 rotor/viscose	20	267	10.5	13.4
3 air-jet/viscose	20	286	12.3	14.3
4 SiroSpun® /viscose	20	393	13.6	19.7

Four samples of weft double jersey knitted fabrics were made using circular double-bed knitting machine with E17 gauge and needle bed diameter of 200 mm (8 inches). All dry relaxed knitted fabrics (raw samples) were finished in the production plant: firstly washed thoroughly at 40 °C, further treated with the addition of detergent, bleaching/dyeing and stabilization agent at 95 °C; rinsed, cold washed with neutralization and softening; and

dried at 150 °C with a passage rate of 0.15 m/s. Mass per unit area, thickness and total number of wales and courses per unit length of raw and finished knitted fabrics are shown in Table 2.

Table 2: Characterisation of raw and finished viscose knitted fabrics

Knitted fabrics sample	Mass per unit area (g/m ²)	Thickness		Total number of wales/cm	Total number of courses/cm
		Th (mm)	CV (%)		
1 Ring viscose/raw	170	0.61	5.13	22	12.5
1 Ring viscose/finished	146	0.42	2.76	21	12.5
2 Rotor viscose/raw	155	0.65	3.35	20	12.5
2 Rotor viscose/finished	175	0.42	1.25	20	13.5
3 Air-jet viscose/raw	144	0.81	0.83	18	12.5
3 Air-jet viscose/finished	143	0.67	2.50	17	14
4 SiroSpun® viscose/raw	188	0.63	1.94	21	13.5
4 SiroSpun® viscose/finished	152	0.54	3.08	20	12.5

Th-thickness, CV-coefficient of variation

With the purpose of analysing the influence of different spun viscose yarns and the knitted fabrics processing level on their properties, after the conditioning (at temperature: 20 ± 2 °C and air relative humidity: 65 ± 4%) the usage quality of raw and finished knitted fabrics were evaluated by determination of:

- breaking strength and breaking elongation according to the EN ISO 13934-1 [3] using the strip method. Arithmetic mean of the five measurements in the length and width directions and coefficient of variation were calculated;
- dimensional change in the length and width directions of knitted fabric in tubular form, after one washing and drying cycle according to the procedure 4M at 40 °C (mild agitation during heating, washing and rinsing) of EN ISO 6330 [4] with non-phosphate ECE reference detergent (without optical brightener) and open-air drying (procedure A, line dry). The percentage change in the length and width of the knitwear was calculated, and the state of whether the dimension has decreased (shrinkage) was expressed by means of minus, or increased (extension) by means of plus;
- spirality after one washing and drying cycle according to the ISO 16322-2 [5] (procedure B);
- permeability of fabrics to air according to the EN ISO 9237 [6] using test surface area of 5 cm² and pressure drop of 100 Pa. Arithmetic mean of the 10 individual readings and coefficient of variation were calculated;
- propensity to surface fuzzing and pilling according to the Martindale method (EN ISO 12945-2 [7]). The knitted fabrics were rubbed with wool abrasant fabric and visually assessed (by grades: 1 – 5) after 125, 500, 1000, 2000, 5000 and 7000 rubbing cycles;
- abrasion resistance by determination of specimen breakdown using the Martindale abrasion tester according to the EN ISO 12947-2 [8]. When using this method the specimens moves according to the Lissajous curve, and standard woven wool fabric is abraded over the entire surface.

3. Results and discussion

The results obtained are presented in Tables 3 - 8.

Table 3: Breaking strength and breaking elongation of raw and finished viscose knitted fabrics

Knitted fabrics sample	Breaking strength				Breaking elongation			
	in length		in width		in length		in width	
	F (N)	CV (%)	F (N)	CV (%)	ε (%)	CV (%)	ε (%)	CV (%)
1 Ring viscose/raw	304.8	6.7	65.1	7.1	50.8	1.7	131.3	5.4
1 Ring viscose/finished	182.7	10.0	60.6	3.5	37.7	5.7	123.3	4.7
2 Rotor viscose/raw	204.7	6.2	64.9	6.3	38.1	3.4	171.8	3.3
2 Rotor viscose/finished	203.0	8.5	63.7	8.8	47.7	3.1	146.1	2.9
3 Air-jet viscose/raw	242.9	8.9	74.9	3.6	44.1	6.2	165.7	3.2
3 Air-jet viscose/finished	146.8	23.7	82.8	5.7	51.1	6.1	119.3	2.5
4 SiroSpun® viscose/raw	317.7	6.2	76.9	7.6	50.7	3.5	135.9	3.3
4 SiroSpun® viscose/finished	194.4	7.6	73.3	5.7	37.3	7.8	126.9	4.5

F-breaking strength, ε-breaking elongation, CV-coefficient of variation

Table 4: Changes in dimensions in the length and width directions of raw and finished viscose knitted fabrics after one washing and drying cycle

Knitted fabrics sample	Dimensional stability in length (%)	Dimensional stability in width (%)
1 Ring viscose/raw	-20.0	+13.3
1 Ring viscose/finished	-15.0	+8.3
2 Rotor viscose/raw	-19.4	-11.7
2 Rotor viscose/finished	-12.5	-6.7
3 Air-jet viscose/raw	-23.8	+7.3
3 Air-jet viscose/finished	-8.1	+5.7
4 SiroSpun® viscose/raw	-15.6	+10.0
4 SiroSpun® viscose/finished	-11.3	+6.7

Table 5: Visually assessed propensity to surface pilling of raw and finished viscose knitted fabrics by grade of pilling

Knitted fabrics sample	Number of pilling rubs					
	125	500	1000	2000	5000	7000
1 Ring viscose/raw	4/5	4	3	3	2/3	2
1 Ring viscose/finished	4/5	4	4	3	2/3	2
2 Rotor viscose/raw	4/5	4/5	4/5	4/5	4	3/4
2 Rotor viscose/finished	5	5	4/5	4/5	3	3
3 Air-jet viscose/raw	5	4/5	4/5	4	4	3/4
3 Air-jet viscose/finished	5	4/5	4/5	4	4	3/4
4 SiroSpun® viscose/raw	4	4	3	3	2/3	2
4 SiroSpun® viscose/finished	4	4	3	3	2/3	2

Table 6: Face of viscose knitted fabrics test specimen at the end of reached rubbing stage during assessment of propensity to surface pilling

Knitted fabrics sample	Number of pilling rubs				
	500	1000	2000	5000	7000
1 Ring viscose/raw					
1 Ring viscose/finished					
2 Rotor viscose/raw					
2 Rotor viscose/finished					
3 Air-jet viscose/raw					

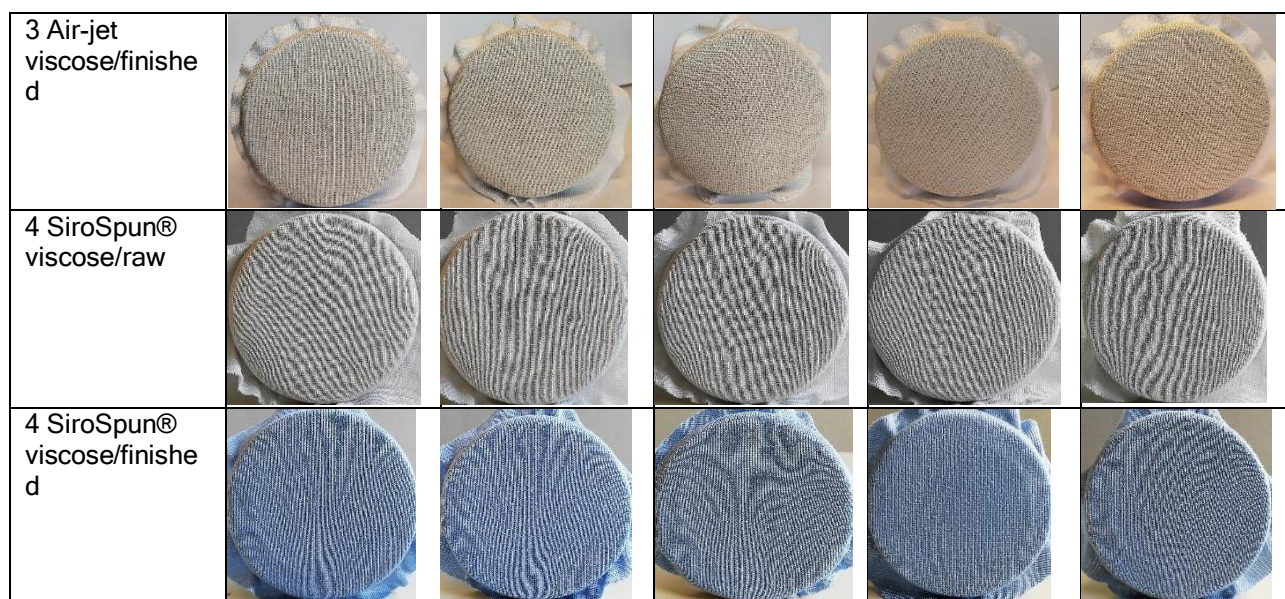



Table 7: Permeability of raw and finished viscose knitted fabrics to air

Knitted fabrics sample	Air permeability		
	R (mm/s)	R (dm ³ /min cm ²)	CV (%)
1 Ring viscose/raw	1752.9	52.5	6.20
1 Ring viscose/finished	1942.1	58.1	4.88
2 Rotor viscose/raw	3604.9	107.9	3.06
2 Rotor viscose/finished	2478.1	74.2	8.23
3 Air-jet viscose/raw	3249.7	97.3	1.61
3 Air-jet viscose/finished	2321.6	69.5	4.65
4 SiroSpun® viscose/raw	2072.2	62.0	9.22
4 SiroSpun® viscose/finished	2214.0	66.3	6.15

R -air permeability, CV-coefficient of variation

Table 8: Abrasion resistance of raw and finished viscose knitted fabrics - determination of specimen breakdown

Knitted fabrics sample	Number of rubs to reach endpoint		Face of test specimen at the end of the test	
	raw	finished	raw	finished
1 Ring viscose	50 000	40 000		
2 Rotor viscose	35 000	30 000		
3 Air-jet viscose	35 000	35 000		

4 SiroSpun® viscose	45 000	45 000		
---------------------	--------	--------	--	---

After finishing the thickness of all viscose knitted fabrics samples is reduced (Table 2). Changing of mass per unit area additionally affects the dimensional change of knitwear (confirmed by changing of number of wales and courses/cm). That is also confirmed with results of air permeability of raw and finished viscose knitted fabrics presented in Table 7.

Breaking strength of knitted fabrics (Table 3) is conditioned by breaking strength of the yarn used for knitting (shown in Table 1). Rotor spun yarn have lower tenacity when compared with ring and SiroSpun® ring viscose yarns. In the length direction of all knitwear samples it has been found higher values of breaking strength and lower breaking elongation, and in the width direction the lower breaking strength and higher breaking elongation. After finishing the breaking strength of all knits in length direction is reduced, primarily because of the dimensional change of knitwear.

Fabric shrinkage is a serious problem for knitwear, originating from dimensional changes in the fabric, particularly stitches. The on-balanced condition of viscose knitwear is quite easy changing when knitwear is laundered and dried. Therefore, the geometrical dimensions of knitwear are changing [9, 10]. All raw knitted fabrics show high deformability after laundering (shrinkage in length direction and extension in width direction (Table 4)), except the fabric made of viscose rotor yarns. Changes in dimensions are significantly reduced after finishing. The fabric made from rotor spun yarns had relatively better dimensional stability (shrinkage in the booth directions). After laundering all the tested knitted samples do not show the tendency to spiral deformation.

With increasing the number of abrasion cycles, in all knitwear samples increases the propensity to surface fuzzing and pilling (Tables 5 and 6). Best rated knitwear are those made of viscose air-jet spun yarns because of their lower hairiness and specific structure when compared with ring and rotor spun yarns.

Yarn structure, linear density, twist and hairiness are the main properties which affect abrasion resistance of textile materials. The production method of yarn has also an influence on the abrasion resistance [10]. Knitted fabrics from ring spun yarns have better abrasion resistance than knitted fabrics from rotor spun yarns. Ring spun yarns are hairier but more compactly structured than rotor yarns, this well aligned compact structure doesn't promote easy fibre wear of. SiroSpun® is a modified ring spinning process that two rovings per spindle are fed to the drafting system within specially developed condensers separately and drafted simultaneously. Fabric knitted from SiroSpun® yarns show better abrasion resistance than ring, air-jet and rotor spun yarns (Table 8) because of better evenness, hairiness, regular and tightly structure. By finished knitwear samples made of SiroSpun® and single ring viscose yarns, specimen breakdown occurs by 45 000 and 40 000 abrasion rubs. This can be connected also with the fact that the ring spun yarns have higher tenacity (Table 1), and viscose fibres are highly twisted on the surface of the yarn.

4. Conclusion

On the basis of the results obtained, it was concluded that for selection of the viscose spun yarn for knitted fabrics production is necessary to consider their price, structure and the characteristics, but also the fact that yarn spinning technique, as well as the process of knitted fabric finishing significantly influence knitwear usage quality.

Acknowledgement

This paper is funding by the Croatian science foundation within the project IP-2016-06-5278 (Comfort and antimicrobial properties of textiles and footwear, principal investigator: prof. Zenun Skenderi, PhD).

References

- [1] Tomljenović, A. et al: Durability Assessment of Functionally Printed Knitted Fabrics for T-Shirts, *Fibres & Textiles in Eastern Europe*, Vol. 24 (2016) No. 4, pp. 129-138, ISSN 1230-3666

- [2] Kopitar, D. et al: Surface Friction Coefficient of Spun Yarn, *Proceedings of International Conference MATRIB 2016, Materials, Tribology, Recycling*, Žmak I. (Ed.), pp. 178-188, ISBN 2459-5608, Vela Luka, Croatia, 23-25 June 2016, : Croatian Society for Materials and Tribology, Zagreb (2016)
- [3] EN ISO 13934-1:2013 Textiles - Tensile properties of fabrics - Part 1: Determination of maximum force and elongation at maximum force using the strip method
- [4] EN ISO 6330:2012 Textiles - Domestic washing and drying procedures for textile testing
- [5] ISO 16322-2:2005 Textiles - Determination of spirality after laundering - Part 2: Woven and knitted fabrics
- [6] EN ISO 9237:1995 Textiles - Determination of the permeability of fabrics to air
- [7] EN ISO 12945-2:2000 Textiles - Determination of fabric propensity to surface fuzzing and to pilling - Part 2: Modified Martindale method
- [8] EN ISO 12947-2:2016 Textiles - Determination of the abrasion resistance of fabrics by the Martindale method - Part 2: Determination of specimen breakdown
- [9] Hashimoto, Y. et al: Effect of Washing and Drying Conditions on Dimensional Change in Various Articles of Knitted Clothing, *Journal of Fiber Bioengineering and Informatics*, Vol. 11 (2018) No. 4, pp 227-240, ISSN 1940-8676
- [10] Mikučionienė, D. & Laureckienė, G: The Influence of Drying Conditions on Dimensional Stability of Cotton Weft Knitted Fabrics, *Materials Science*, Vol. 15 (2009), No. 1, pp. 64 -68, ISSN 1392-1320
- [11] Ōzdil, N. et al: Analysis of Abrasion Characteristic in Textiles, In *Abrasion Resistance of Materials*, InTech, ISBN 978-953-51-0300-4, Rijeka, (2012), pp. 119-146

Authors:

Antoneta TOMLJENOVIC (corresponding author);
Zlatko VRLJIČAK; Juro ŽIVIČNJAK; Mateja VLAINIĆ; Ivana BONIĆ
University of Zagreb Faculty of Textile Technology
Prilaz baruna Filipovića 28a, HR-10000 Zagreb, Croatia
Phone: +385 1 3712522 Fax: +385 1 37712599
Phone: +385 1 3712578 Fax: +385 1 37712599
Phone: +385 1 3712524 Fax: +385 1 37712599

E-mail: antoneta.tomljenovic@tff.unizg.hr
E-mail: zlatko.vrljicak@tff.unizg.hr
E-mail: juro.zivicnjak@tff.unizg.hr
E-mail: matea.vlainic@gmail.com
E-mail: ivanabonic@gmail.com

THE INFLUENCE OF AGING ON TENSILE PROPERTIES OF KNOTTED YARNS

Ivana SALOPEK ČUBRIĆ & Antonija PETROV

Abstract: For a number of human activities, a knowledge on yarn knotting techniques is extremely important in order to ensure high level of safety. This paper focuses at investigation of knotted yarns used for scouting, but can also be applied for similar activities, like mountain climbing. In the introductory part of the paper is given a review of the scouting activity and importance of yarn knotting. It is followed by results of previous investigation. The main objective of the present paper is to examine the tensile properties of knotted yarns, i.e. yarns that are tied to various scouting knots. The investigations are carried out on knotted yarns in 4 different states: (a) in dry state, (b) in dry state, after exposure to aging in water, c) in wet state, after exposure to aging in water, (d) in dry state after 100 cycles of abrasion and (e) in dry state after 300 cycles of abrasion. The results obtained are compared and conclusions are drawn. The importance of the presented examination is evident in the fact that knowledge on the tensile properties of targeted samples is essential for the preservation of personal and general safety of the individuals who use them.

Keywords: yarn, tensile properties, aging, wet state, dry state, abrasion

1. Introduction

Scouting aims to build and develop young people's confidence, sense of adventure and outdoor skills, as well as encouraging them to explore their beliefs, attitudes and creativity. It offers them the independence to put these skills into practice at camps and international trips. Scouting today has followers in 210 countries and territories of the world, with more than 25 million members. Scouting, in short, can be explained as education outside formal and traditional institutions. It is a training for the youth with purpose of reaching the full physical, intellectual, emotional, social and spiritual potentials. In doing so, harmonious living with nature and in nature, knowing and safeguarding its laws, have a primary place. Robert Baden Powell first launched the Scout movement in 1907 in the UK. The year 1907 is considered the year the Scout movement was founded because on August 1, 1907, Baden-Powell organized a test camp for 20 boys on the Isle of Browns in England. He was inspired by their enthusiasm and wrote the book *Scouting for Boys* [1].

People have been tying knots on yarns for thousands of years. Today, despite the development of technology in every field, knots are still as necessary as were in the past. The ability to tie knots is a useful skill. Understanding the purpose of a particular type of knot and when it should be used is equally important. Using a wrong knot in single activity or situation can result in negative consequences. All knots have a certain purpose and it is just as important to understand what that purpose is, and when the knot is used, as having the ability to tie it appropriately. Until the 20th century, ropes were made from vegetable fibers from various sources: such as flax and hemp, agave leaves (sisal) and abaca (Indian hemp), fiber shells coconut, silk, wool, camel hair and human hair [3]. Natural fibers are attractive for use, but they also have a number of disadvantages. It is impossible to untie a knot of natural fiber if it gets wet. In icy conditions, ropes freeze, brittle fibers break and get damaged, and the tightness of the rope decreases. Natural fiber ropes are solid but not like synthetic ropes made of fibers of continuous length. The nylon rope is more than twice as tight as the manila rope of equal length, and is half as light and four times as durable. All synthetic ropes have almost the same characteristics: high strength, durability, good sorption properties, do not rot or lose strength in seawater and are generally resistant to chemical damage. Although more resistant synthetic, ropes also have their disadvantages, just like natural fiber ropes. Synthetic ropes are sensitive to friction heat, they are very smooth and easy to untie [3].



In the preliminary investigation [4, 5], samples of yarn are tied to different knots, i.e. *Figure eight knot*, *Figure eight double knot*, *Square knot*, *Overhand knot*, *Granny knot*, *Double overhand knot*, *Bowline knot* and *Overhand bend knot*. On the basis of the examination of the tensile properties of yarns tied to various scouting knots, it was found that the breaking elongation was highest for the yarn tied to figure eight double knot, that is widely used in climbing and caving. Lowest breaking elongation had a yarn tied to overhand knot. As far as the breaking force is concerned, the highest values have yarns tied to granny knot and square knot.

For this experiment are, based on the previous outcomes, selected four typical knots. In the focus of the research is investigation of tensile properties of knotted yarns under simulated conditions of aging, more precise exposure to water and abrasion.

2. Experimental

For the purpose of investigation are selected four types of knots, all presented in the Table 1.

Table 1: List of selected knots [8-10]

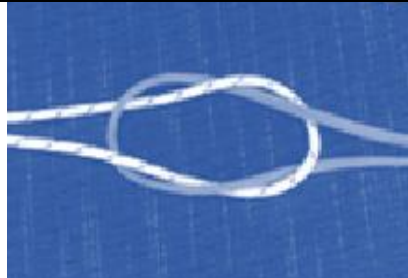
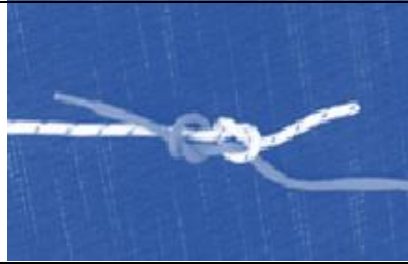
Knot	Name	Image	Description
K1	Multiple overhand knot		Multiple overhand knot is a more complex structure of an ordinary knot. It is obtained by repeatedly passing through the loop of a regular knot. It serves as stop knot, so it can be difficult to untie it once tightened.
K2	Figure eight knot		This knot is reminiscent of number eight and is relatively simple to tie. The figure-eight knot is a type of stopper knot. According to the literature, it is very reliable and is characterized by a low probability of accidental untying.
K3	Granny knot		This type of knot is mainly used for the continuation of two strands. It consists of two half-knots. This knot is asymmetric and determined as rather unreliable. Therefore, it is necessary to secure it further, since the knot itself can easily be untied.
K4	Fishing knot		The fishing knot is also known under the name English knot or rafting knot. Its application is ideal slippery ropes and monofilaments. It provides high level of security, but is very difficult to untie. A properly tied knot needs to be symmetrical to fulfil its function.

The measurements are carried out on knotted yarn (raw material 100% CV, 50x3x3 tex) in 4 different states, i.e.:

- **a:** in dry state,
- **b:** in dry state, after exposure to aging in water for period of 40 days,
- **c:** in wet state and after exposure to aging in water for period of 40 days,
- **d:** in dry state after 100 cycles of abrasion and
- **e:** in dry state after 300 cycles of abrasion.

The designation of yarns is given in the Table 2.

Table 2: Yarn designation

Knot designation	Yarn designation considering description of state				
	a	b	c	d	e
K1	K1a	K1b	K1c	K1d	K1e
K2	K2a	K2b	K2c	K2d	K2e

K3	K3a	K3b	K3c	K3d	K3e
K4	K4a	K4b	K4c	K4d	K4e

3. Results and discussion

The results of measured breaking force and breaking elongation are used to define relative change of measured properties due to exposure to water or abrasion. The change is given in relation to breaking force/breaking elongation of knotted yarns measured in dry state (i.e. state “a”), without exposure to water or abrasion. The results are shown in the figures 1 and 2.

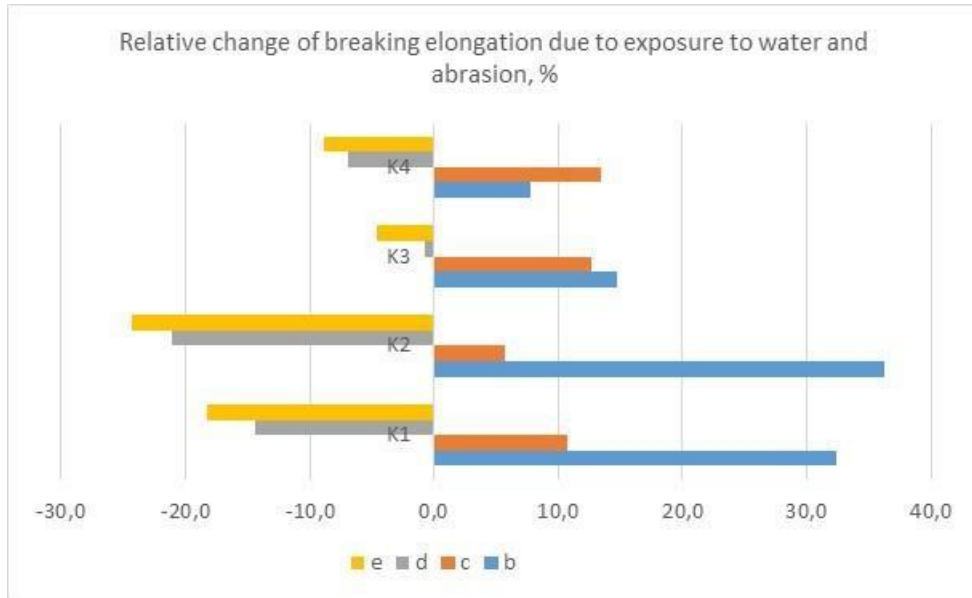

Figure 1: Breaking elongation of knotted yarns

The results presented in the Figure 1 indicate that exposure of knotted yarns to aging in water led to significant increase of breaking elongation. The increase of breaking elongation in comparison to breaking elongation of non-exposed samples is up to 13% (when investigated in wet state) and up to 36% (when investigated in dry state). The increase of observed property is most prominent for the yarn tied to figure eight knot (sample K2b). The abrasion of knotted yarns affected decrease of breaking elongation for all observed knotted yarns for up to 32% (sample K2e). After only 100 cycles of abrasion, the decrease of observed property is up to 21%.

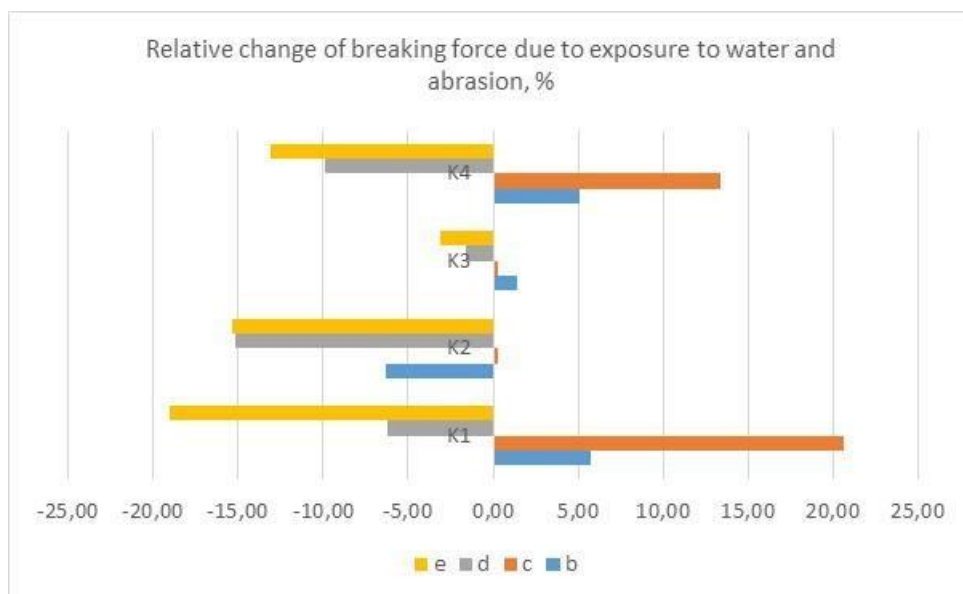

Figure 2: Breaking force of knotted yarns

The results presented in the Figure 2 demonstrate the changes of breaking force due to exposure to water and abrasion. As can be seen, there is no consistency in the behaviour of the knotted yarns due to water exposure. Precisely, there is higher increase of breaking force for the yarns knotted to multiple overhand knot and fishing knot (samples K1b, K1c, K4b, K4c) and decrease of breaking force for the yarn knotted to figure eight knot (sample K2b). The abrasion of knotted yarns (through both 100 and 300 cycles) affected decrease of breaking force for all observed samples up to 18%. The lowest decrease is observed for the yarn tied to granny knot (sample K3d).

4. Conclusion

For scouts, as well as other groups of people that use knotted yarns, it is important that the knots tied to the yarn do not slip and that are tight enough to prevent interruptions and unintended consequences. The aim of this paper was to investigate the effect of yarn aging (by exposure to water and abrasion) to the changes of breaking force and breaking elongation.

The results indicated the following:

- exposure of knotted yarns to aging in water led to significant increase of breaking elongation (up to 36%) and is most prominent for yarn tied to figure eight knot. The same knot is the only one among selected knots that demonstrated decrease of breaking force after exposure.
- the abrasion affected decrease of both breaking elongation and breaking force for all observed samples (up to 32%). The lowest decrease is observed for the yarn tied to granny knot.

In the practical application of knotted yarns, and especially in the situations of survival, it is essential to know which knot is more secure. Therefore, the results of this study have practical application and should be used when selecting optimal knot for defined purpose. The future investigations may be expanded by larger number of samples or more specifically defined aging conditions.

References

- [1] Bailey, J.: Scouting Skills: A Complete Guide, Doubleday, 2010
- [2] Prskalo, I., Kičina, B: Scouts and school, Faculty of Education University of Zagreb, Zagreb (2007)
- [3] Olliffe, N., Olliffe M. Basic knots, Zagreb, Mozaik knjiga (2012)
- [4] Petrov A.: Tenacity of yarns tied to scout knots, Undergraduate thesis, University of Zagreb Faculty of Textile Technology (2017)
- [5] Petrov, A.; Salopek Čubrić, I.: The tensile properties of yarns tied to the scout knots, Book of Proceedings of 12th International scientific-professional symposium Textile Science & Economy, Novak, I. (ed.) pp. 179-186, ISSN 1848-9699, Zagreb, Croatia, University of Zagreb Faculty of Textile Technology (2019)
- [6] Olliffe N., Olliffe M.: Basic knots, Mozaik knjiga, Zagreb (2012)
- [7] Nautical info: Litter school of knots, available at <http://www.plovidba.info> (Accessed: Feb 28, 2020)
- [8] Croatian Mountaineering Society: Fishing knot, available at <http://hpd-plocno.com> (Accessed: Feb 28, 2020)
- [9] Petrov A.: Analysis of tensile properties of yarns used in scouting, Diploma thesis, University of Zagreb Faculty of Textile Technology (2019)
- [10] ISO 2062:2009 Textiles – Yarns from packages – Determination of single-end breaking force and elongation at break using constant of extension (CRE) tester

Authors:

Assoc. Prof. Ivana SALOPEK ČUBRIĆ, PhD (corresponding author)
University of Zagreb Faculty of Textile Technology
Prilaz baruna Filipovića 28a, 10000 Zagreb, Croatia
Phone: +385 1 37 12 573

E-mail: ivana.salopek@unizg.ttf.hr

Antonija PETROV, mag. ing. techn. text.
Diadema d.o.o.
Ante Starčevića 11d, 10 360 Sesvete
Phone: +385 91 584 72 60

E-mail: petrov.antonija@gmail.com

CHARACTERIZATION OF YARNS USED TO MAINTAIN DENTAL HEALTH

Ivana SALOPEK ČUBRIĆ & Martina CVETKO

Abstract: *The concept of Oral Health-Related Quality of Life (OHRQOL) has evolved in recent decades, largely thanks to western European countries and the USA. The goal of modern dentistry is not only to improve oral health, but also to improve the overall quality of life of patients. Important role in this segment has the textile industry, due to the fact that specific yarns, called "floss", are produced and used to clean teeth from plaque, bacteria and food debris. The first uses of such yarns were dominantly focused at use of spun yarns produced of natural fibres. Nowadays, natural materials have lost their importance due to the complexity of processing into dental floss, high costs and restricted physical properties.*

The research presented in this paper focuses at investigation of properties of yarns available at the marked and comparison of their properties, specifically, yarn fineness, diameter and tensile properties (breaking force and breaking elongation).

Keywords: *yarn, filament, breaking force, breaking elongation, dental*

1. Introduction

The Oral Health-Related Quality of Life (OHRQOL) concept has been developing in the last few decades, mostly due to the effort of European western countries and the USA. Before that, significant attention wasn't given to this problem. The oral disease only appeared as an unpleasant experience of the patient without significant consequences on health. The goal of modern dentistry is not only to improve oral health, but also to improve the overall quality of life of patients [1]. It is not possible to confirm with certainty the origin and the beginning of the use of dental floss, but anthropologists have found evidence that more ancient civilizations have used a variety of tools to clean teeth, such as pointy sticks and twig. The main precursor of dental floss is horse's hair. In the near history, dental floss became a widespread product around 1815, when the dentist from New Orleans, Dr. Levi Spear Parmly invented a thin, wax thread, to allow his patients more detailed cleaning of the teeth [2]. Dental floss is a thread used to clean teeth from plaque, bacteria and food residues. Hundreds of extremely thin fibers that form dental floss are firmly merged into a single unit. After entering the interdental space, these fibers open like ribbons, performing their own "cutting" action and removing the plaque. Dental floss is used in combination with brushing teeth, and it has been found that its application reduces primarily the appearance of caries and periodontitis, but also the appearance of gingivitis, and halitosis [1].

The base of the dental floss can be made from natural materials (such as wool and silk) or of artificial materials (such as nylon and teflon). Dental floss is usually made from one of the two synthetic compounds specified. Further, it could be coated with wax and can contain aromas, sweeteners and taste enhancers. Natural materials have lost the importance of the appearance of synthetic materials for the manufacture of threads due to the complexity of processing in dental floss, its price, as well as the weaker physical-mechanical properties. Unlike the usual dental floss, consisting of a series of nylon threads, the Oral-B laboratory has produced a thread containing a patented mesh of interwoven fibres that are resistant to cracking and breakage. Spongy texture threads also work in a different way than conventional dental yarn. When entering the interstellar spaces it is thinned, then returns to its original thickness to retain plaque inside the interwoven threads. The Ultra thin thread is soft for sensitive gums, and the thread is pre-cut in length of about 45 cm, recommended by the ADA (American Dental Association). Due to the complicated and prolonged use of dental floss, companies like Philips work to find an equally effective solution, but with much simpler use. Conventional dental floss is thought to be replaced by advanced technological devices in the future [3]. Packaging and packaging design are very important in the sales aspect and product positioning. Packaging is a medium of direct physical contact between the customer and the product. The standard packaging of dental floss implies a box containing between ten and a hundred meters of thread, with a protective blade to separate the desired thread quantity. Recently, the innovations of some manufacturers are a box on which the construction of the thread is located to measure the amount of yarn. It has to be pointed out that there are no strict rules that apply to specification of product related to yarn properties. This segment is largely dependent on the politics of the producer and result is a wide discrepancy of information.

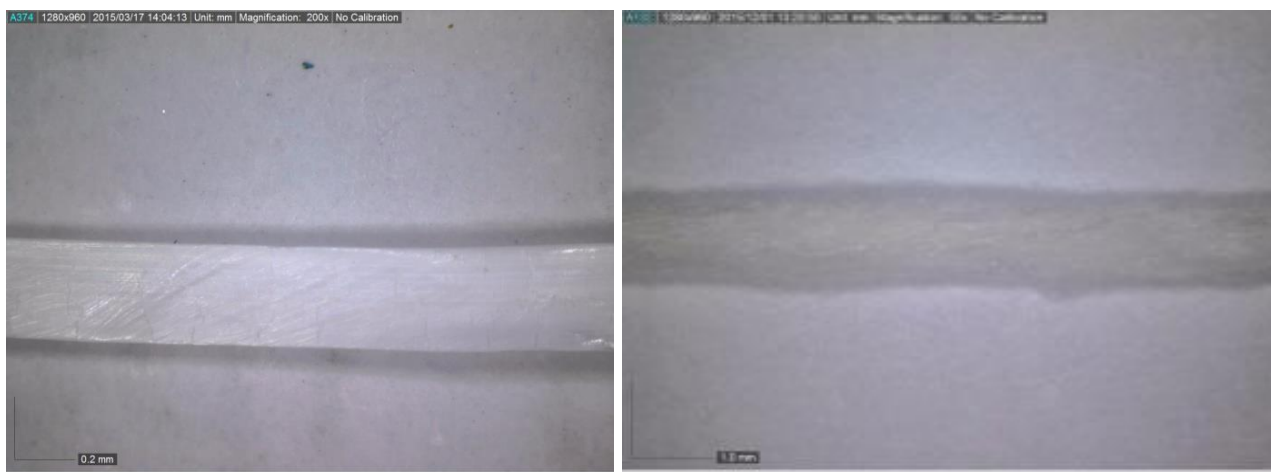

Figure 1: Examples of dental flosses, images taken under magnification of 200x

Previously conducted research in the field was focused towards experimental measurements of floss' properties and attitude of consumers towards flossing and their preferences for purchase. The results of measurements showed that differences within the values of breaking force and elongation of selected samples may be more than 20%. The same stands for the differences in diameter. The results of survey conducted among consumers indicated that advertising plays an important role in convincing consumers to choose certain product. The next influencing factor is positive experience. Among others factors are more pronounced price, brand and floss properties [4].

The aim of the research presented in this paper is to investigate physical-mechanical properties of flosses available on the market and make an incentive to develop product declaration guidelines.

2. Experimental

For the investigation presented in this paper are selected 10 different yarns used as “dental floss” that available are at Croatian market. The specifications of yarns, given by producer, are presented in the Table 1 [5].

Table 1: Specifications of yarns

Yarn designation	Specifications given on product declaration	Yarn designation	Specifications given on product declaration
Y1	PTFE, film, brilliant white	Y9	Soft for the gums, removes plaque, mint flavored
Y2	PL, filament, for sensitive teeth	Y10	For cleaning teeth and toothbrushes
Y3	PA6, filament, antibacterial	Y11	NYLON, filament, fresh taste,
Y4	PTFE, film, brilliant white	Y12	NYLON, filament, unwaxed
Y5	NYLON + PTFE, filament, fresh taste, waxed	Y13	NYLON, filament,
Y6	NYLON, filament, neutral taste, unwaxed	Y14	Ultra-sensitive
Y7	NYLON, filament, ultra-sensitive	Y15	mint flavoured
Y8	PTFE, film	Y16	mint flavored

All presented samples are subjected to investigation of yarn fineness, yarn diameter and tensile properties. The yarn fineness was determined using the ISO 2060 [6].

The yarn diameter is determined from a microscopic image obtained using the Dino-Lite digital microscope. For the exact measurement of diameter, DinoCapture 2.0 software is used. The diameters are determined

using the microscopic image with magnification 200x. Tensile properties of yarns are measured on dynamometer Statimat M produced by Textechno, using the method A, as described in the standard ISO 2062 [7].

3. Results and discussion

The results related to measured yarn fineness and diameter are shown in the Table 2. The results of measured breaking force and breaking elongation are shown in the Figure 2.

Table 2: Yarn fineness and diameter

Property	Yarn designation															
	Y1	Y2	Y3	Y4	Y5	Y6	Y7	Y8	Y9	Y10	Y11	Y12	Y13	Y14	Y15	Y16
Tt	128	202	88	105	88	99	137	114	135	92	80	100	140	120	140	210
CV	2,52	1,77	6,24	3,50	1,70	1,47	1,31	7,89	8,55	7,24	3,45	4,23	1,50	4,30	5,30	3,48
d	0,68	1,22	0,69	0,73	0,79	0,83	1,00	1,29	1,23	0,42	0,40	0,91	1,12	1,35	1,25	1,30
CV	2,96	5,87	4,73	8,42	11,91	7,38	5,30	3,15	3,52	9,65	10,10	10,11	5,30	4,11	4,20	8,40

Legend: Tt (tex) - yarn fineness; CV (%) - coefficient of variation; d (mm) - yarn diameter

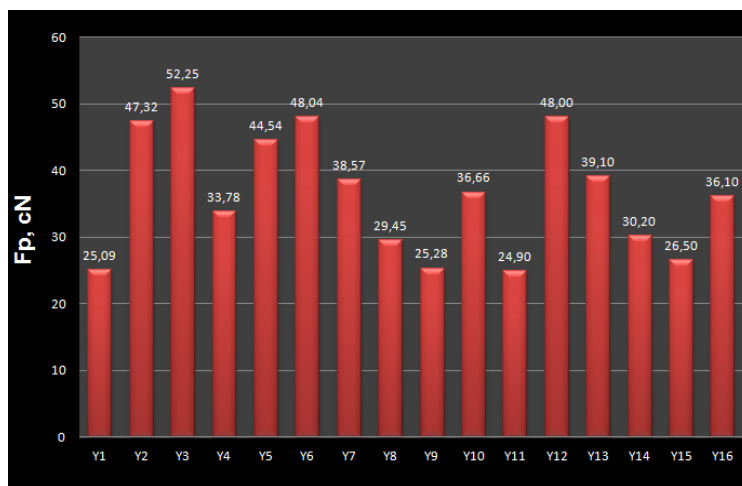

a.

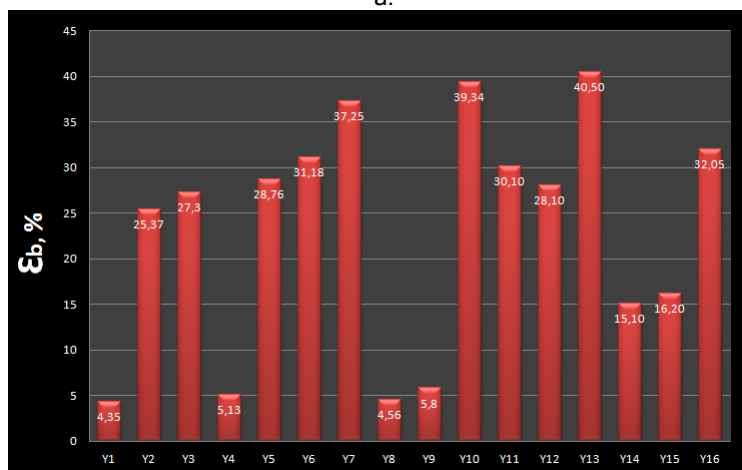

b.

Figure 2: Breaking force (a) and breaking elongation (b) of investigated yarns

The measured yarn fineness is within the range 80-210 tex. This indicates large diversity within examined samples, what is not declared in the product specification. The similar could be concluded if the values of the

measured diameter are observed. Those values are within the range 0,40 -1,35, meaning that diameter of sample Y14 is more than three times bigger than of sample Y11. It has to be pointed out that some producers indicate that produced yarn is more appropriate for individuals with higher interdental spacing between teeth, but this is more an exception than a rule.

Considering this aspect, a sample Y11 would be most suitable for use by individual with a lower interdental spacing. In contrast, the samples Y14 and Y15 have the highest diameters, thus their use is limited to individuals who have a large interdental spacing. The coefficient of variation of the observed property ranges from 2,96% to even 11,91% for sample Y5.

The breaking force of investigated yarns ranges from 24,90 cN to 52,25 cN. It is lowest for the samples Y1 and Y11, for which a possible break during the use may be expected. The breaking elongation ranges from 4,35% to 40,50%. The lowest value has a sample Y1 and the highest sample Y13. The results of both breaking force and breaking elongation measurement indicate significant differences between samples what is expected to be noticed during regular use on daily basis.

4. Conclusion

The results of the study on physical-mechanical properties of different yarns used for flossing pointed to the following:

- the fineness of the examined yarns is in the range 80 to 210 tex,
- the values of the diameter are in the range 0,40 to 1,35 mm,
- the breaking force of the samples ranges from 24 to 52 cN,
- the breaking elongation is within the range 4% to 40%.

The results of measurement indicated significant differences between investigated samples in all observed segments. This leads to the need for further analysis of yarns (both from the aspect of physical-mechanical properties and microbiological properties) resulting in a more comprehensive declaration of the products that should be obligatory for each producer

References

- [1] Cvetko, M.: Analysis of yarns used for dental health preservation, Thesis, University of Zagreb Faculty of Textile Technology, Zagreb (2019)
- [2] Colgate: Flossing; available at <https://www.colgate.com/en-us/oral-health/basics/brushing-and-flossing/how-to-floss> (Accessed: Feb 27, 2020)
- [3] Caufield PW, Li Y., Dasanayake A.: Dental caries: an infectious and transmissible disease, *Compend Contin Educ Dent.*, **26** (2005), 5 Suppl 1, 10-6.
- [4] Salopek Čubrić, I.; Vilus, T.; Čubrić, G.: Investigating Mechanical Properties of Filament Yarns Used for Health Preservation, *Book of Proceedings of the 6th International Ergonomics Conference ERGONOMICS 2016 - Focus on synergy*, Sušić A.; Jurčević Lulić T.; Salopek Čubrić I.; Sumpor D.; Čubrić G. (ed.), pp. 301-306, ISSN 1848-9699, Zagreb, June 2016, Croatian Ergonomics Society, Zagreb (2016)
- [5] Cvetko, M.: Characterization of properties of yarns used in dental medicine, *Thesis*, University of Zagreb Faculty of Textile Technology, Zagreb (2016)
- [6] ISO 2060: 1994 Textiles – Yarn from packages – Determination of linear density (mass per unit length) by the skein method
- [7] ISO 2062: 2003 Textiles — Yarns from packages — Determination of single-end breaking force and elongation at break using constant rate of extension (CRE) tester

Authors:

Assoc. Prof. Ivana SALOPEK CUBRIC, PhD (corresponding author)
University of Zagreb Faculty of Textile Technology
Prilaz baruna Filipovica 28a, 10000 Zagreb, Croatia
Phone: +385 1 37 12 573

E-mail: ivana.salopek@unizg.ttf.hr

MARTINA CVETKO, mag. ing. techn. text.
Boxmark Leather d.o.o.
Gospodarska ulica 12, 42202 Trnovec Bartolovečki, Croatia
Phone: +385 99 517 59 48

E-mail: cvetkomartina.301@gmail.com

PLASMA PRE-TREATMENTS IMPROVES ANTIMICROBIAL PROPERTIES OF BOVINE SPLITTED LEATHER

Sanja ERCEGOVIĆ RAŽIĆ; Jadranka AKALOVIĆ; Tomislav IVANKOVIĆ; Jelena PERAN;
& Katarina IŠTEF

Abstract: This paper presents the application of oxygen and argon plasma pre-treatments in combination with 1,2,3,4 - butantetracarboxylic acid (BTCA) and chitosan, as part of research of pre-treatment processes for bovine leather tanned with various tanning agent. Pre-treatments of leather-tested substrate were conducted using different gases in order to assess different impacts of chemically reactive oxygen and inert argon gas on leather surface properties. The tests were carried out on bovine chrome tanned cleaved leather. Simple drop test was used for testing hydrophilicity of the sample, while the surface morphological changes were analysed using SEM microscopy. In order to examine leather performance in conditions of usage, the permeability of alkaline sweat solution under defined conditions was measured. Antimicrobial efficacy of treated leather sample was tested according to agar diffusion plate test against two bacterial species *Staphylococcus aureus* and *Klebsiella pneumoniae*. Based on the obtained results it can be concluded that applied plasma pre-treatments in optimized process conditions can contribute to the improvement of functional (antimicrobial) properties as well as wearability in conditions of use, primarily intended for footwear insole and similar products.

Keywords: Plasma surface pre-treatments, semi-processed bovine splitted leather, chitosan, SEM analysis, sorption properties, antibacterial activity.

1. Introduction

Natural leather as a unique natural biological material consists of several layers (*epidermis* - a thin cellular outer layer, *dermis* and *subcutaneous* layer - inner layer) and represents a heterogeneous nano-fibril system (Figure 1a). The dermis layer contains intertwined collagen fibers, which represent the most important layer of raw leather for obtaining the finished product. Collagen fibers are made of fibrils - elemental fibers placed in parallel, slightly bended and interconnected, and contribute to different thicknesses of collagen fibers. The dermis is additionally composed of two layers - *papillar* (upper layer composed of thinner collagen fibers) and *reticular* (lower layer composed of thicker bundles of collagen fibers). The reticular layer is a more complex and metabolically active layer consisting of thicker bundles of collagen fibers, intertwined in a complex three-dimensional network. The unique property of the natural leather is strength of the leather that is determined by the orientation of the fibrils - high strength leather has fibrils mostly parallel to the surface and a smaller interlacing angle, while the weaker leather has a higher interlacing angle with fibrils that are not so parallel to its surface (Figure 1b) [1-5].

The industry of leather is one of the biggest polluters of the environment, so it is necessary to develop environmentally friendly leather processing methods. A major problem is the implementation of satisfactory treatments, which are mostly carried out by conventional procedures, and are usually very harmful to the environment. The use of plasma as a medium for processing is an acceptable technique to achieve desired properties. One of the advantages of cold plasma is its applicability to all types of materials, and the possibility of various modifications without negative effects on the basic (mechanical) properties of the material, and without high consumption of chemicals and energy [6].

Plasma treatment of the leather leads to modifications in the surface layer, so-called surface cleaning and its activation thus achieving better hydrophilicity for some new chemical reactions. Using plasma technology is possible to apply chemical agents in monomeric form with the ability to polymerize with the substrate, resulting in cleavage or crosslinking of the agent on the activated surface, in order to achieve or improve the desired functional properties [6].

The emphasis of this paper is application of an ecologically acceptable technique of cold plasma, in achieving of satisfactory sorption and antibacterial properties of the leather under the usage conditions (for footwear insole, primarily), by surface modifications of semi-processed bovine chrome tanned splitted leather, with plasma and ecological bio-agent chitosan.

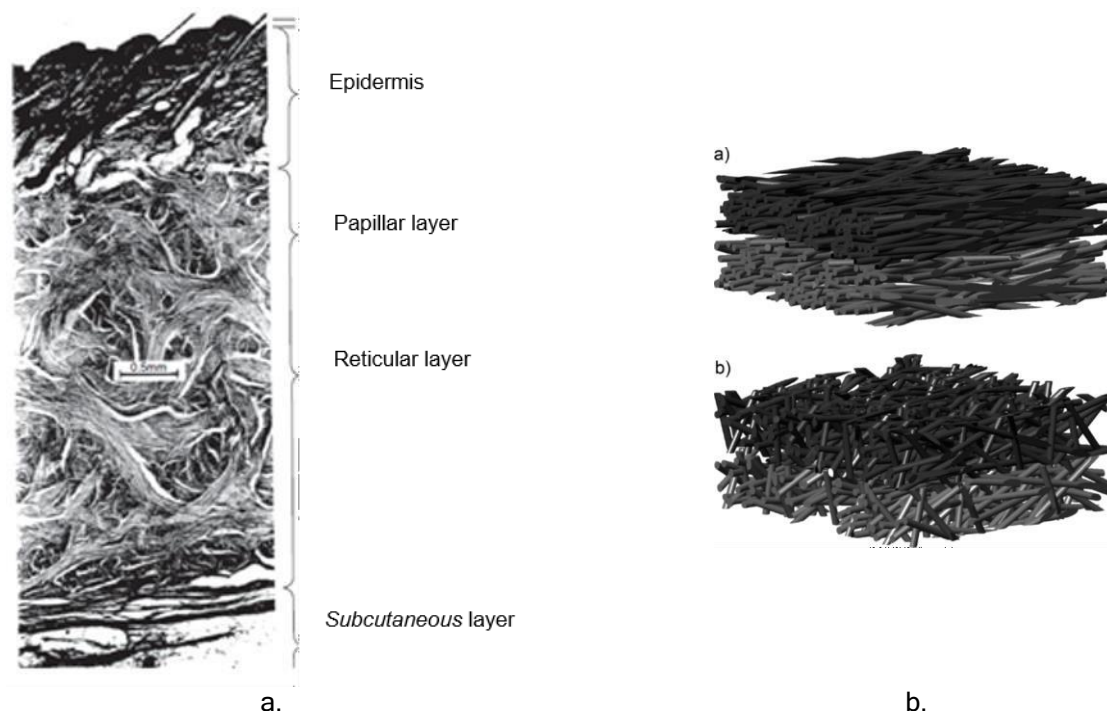

Figure 1: a - Cross-section of bovine leather [4]; b - Schematic of collagen fibrils orientation; a - high strength leather, b - weaker leather [5]

2. Experimental

2.1 Material and methods

Industrially prepared semi-processed bovine chrome tanned leather of hydrophobic properties was supplied by Viviani company (Rešetari, Croatia). The specification of the bovine leather is listed in Table 1. 1,2,3,4 - butantetracarboxylic acid (BTCA) used in pre-treatment was purchased from Sigma-Aldrich. Chitosan ($C_{56}H_{103}N_9O_{39}$, medium molecular weight, 100 -300 kDa) used in treatment of pre-treated leather (labelled as CH, 1% solution dissolved in 0,1 mol/L acetic acid) was purchased from Acros Organics, respectively. Bacterial species *Staphylococcus aureus* and *Klebsiella pneumonia* were used for antibacterial efficiency tests.

Table 1: Specification of tested leather

Sample name	Thickness [mm]	Sample description	Sample appearance
chrome/crust bovine splitted leather - natural	1.0 - 1.2	semi-processed bovine chrome tanned, hydrophobic leather	

2.2 Plasma pre-treatment

For plasma pre-treatments, we used oxygen and argon gases (purity 99.998%, by Messer) at a defined pressure, gas flow and constant frequency of 40 kHz in a low-pressure plasma system (NANO LF, Diener electronic), Table 2. To determine the effect of exposure time and power on leather surface properties, samples were treated for 10 minutes under 500 and 800 W.

Table 2: Plasma pre-treatment conditions

Pre-treatment/gas	t [min]	P [W]	p [Pa]	q [cm ³ /min]	$l \times d$ [mm]
1. oxygen	10	500	32	220	100x100
2. oxygen		800			
3. argon		500			

To remove moisture and consequently accelerate vacuum acquirement, samples were dried at 50°C for 24 hours prior to plasma pre-treatment.

2.3 Plasma treatment

For plasma polymerization process, we used pure BTCA (Sigma-Aldrich) as reagent (in monomer bottle) at a pressure of 50 Pa, gas flow of 200 cm³/min and frequency of 40 kHz in a low-pressure plasma system (NANO LF, Diener electronic). To determine the effect of exposure time and power on polymerization rate, samples were treated for 30 minutes under 100 W.

2.4 Spraying method

In the second part of the experiment, 1% chitosan solution was applied on the plasma treated leather samples by spray method in order to achieve antibacterial effectiveness. For enhanced deposition of chitosan as antibacterial agent, plasma pre-treated leather substrate was sprayed with chitosan solution for 5 second and dried at 65°C for 15 minutes.

2.5 Surface morphology

The surface morphology of untreated and plasma pre-treated leather substrates was analysed with a Jeol scanning electron microscope (SEM) (JEOL LV-6060) at 100x and 2000x magnifications. In order to obtain conductivity, samples were coated with gold for 20 minutes, using a sputter coater before analysis. Results are presented at Figures 1.-3.

2.6 Sorption properties

The effect of plasma pre-treatment on wicking (hydrophilicity) properties was evaluated by determining absorption time of the water drop according to AATCC 79-2000 standard. Results are presented in Table 3.

2.7 Permeability of alkaline sweat solution

For examining the behaviour of the leather under the usage conditions (for footwear insole), the permeability of the alkaline sweat solution is measured under defined conditions. The testing of absorbency and permeability of alkaline sweat solution under simulated laboratory conditions was performed on untreated and pre-treated samples. A previously weighed sample dimensions 100 mm x 100 mm was placed on a Petri dish containing an alkaline sweat solution with a volume of 40 ml (pH 8 ± 0.2). The test was performed in an oven at 37 °C for 8 hours. At the end of the test, the mass of the samples was determined (m₂, g), the remaining volume of the sweat solution, while the amount of sweat leaked (ΔV , ml) was calculated.

2.8 Antibacterial activity

Antibacterial activity against *S. aureus* (ATCC 25 923) and *K. pneumoniae* (ATCC 11 296) in treated leather samples was determined with the qualitative agar diffusion plate test following ISO 20645:2004 standard and was compared with an untreated leather sample. The final assessment of antibacterial activity included the inhibition zone and the growth of the bacteria under the specimen.

3. Results and discussion

3.1 SEM analysis

The micrographs of untreated chrome tanned splitted leather sample (Figure 2) shows that the collagen fibers are almost vertical oriented to the surface, and of different fineness with visible tangled fibrils along the visible surface. After plasma pre-treatments and treatments with BTCA/CH solutions, collagen fibers are oriented parallel to the surface with more bundles sticker together due to the agent applied during treatments. The overall structure of the leather surface is smoother with a residual agent on the surface of the bundles of collagen fibers, presented at Figures 3 and 4.

This orientation of the fibers is present in leather of higher strength in which the fibers are oriented parallel to the surface of the leather with a smaller angle of interlacing compared to leather of lower strength, and will be the focus in future research.

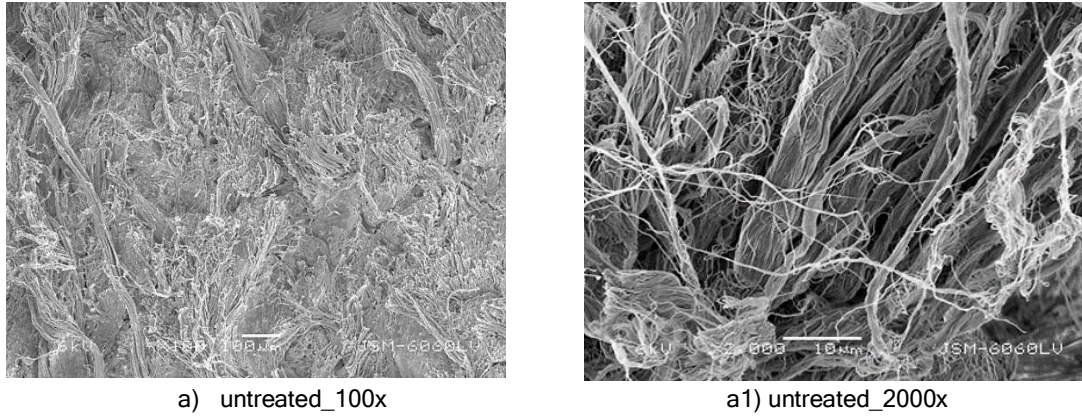

Figure 2: SEM micrographs of untreated leather samples; observed at 100x and 2000x magnifications.

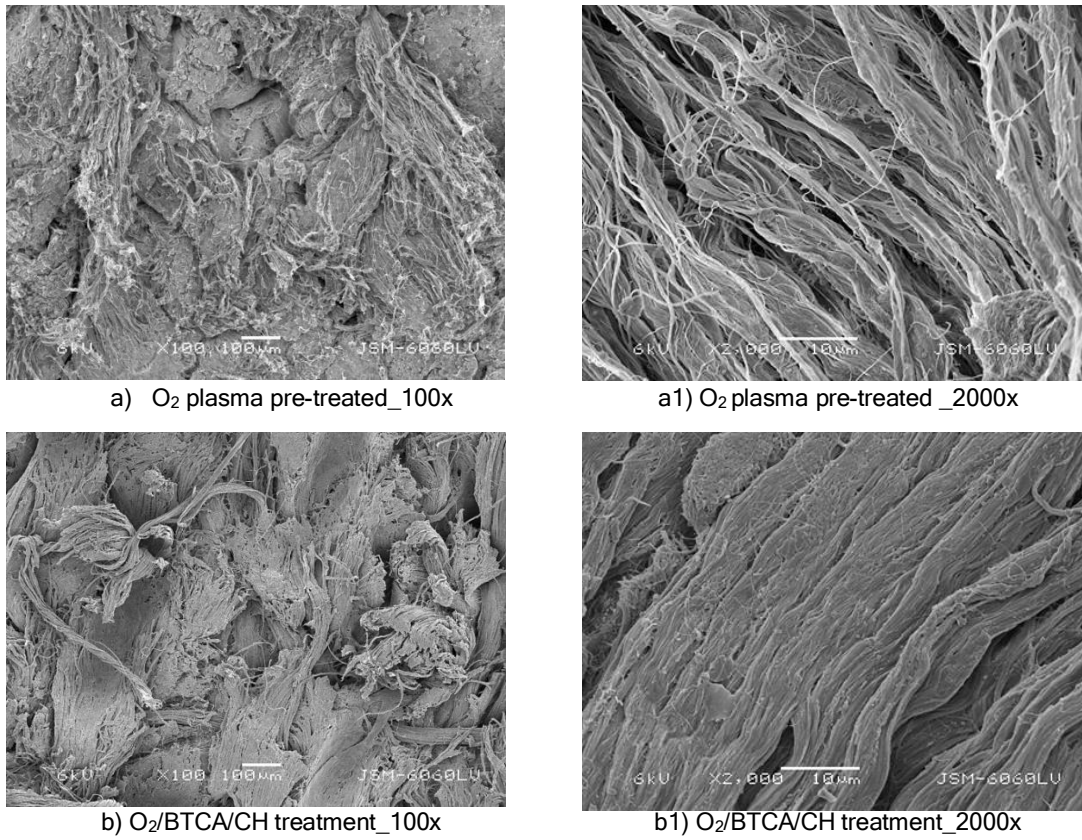
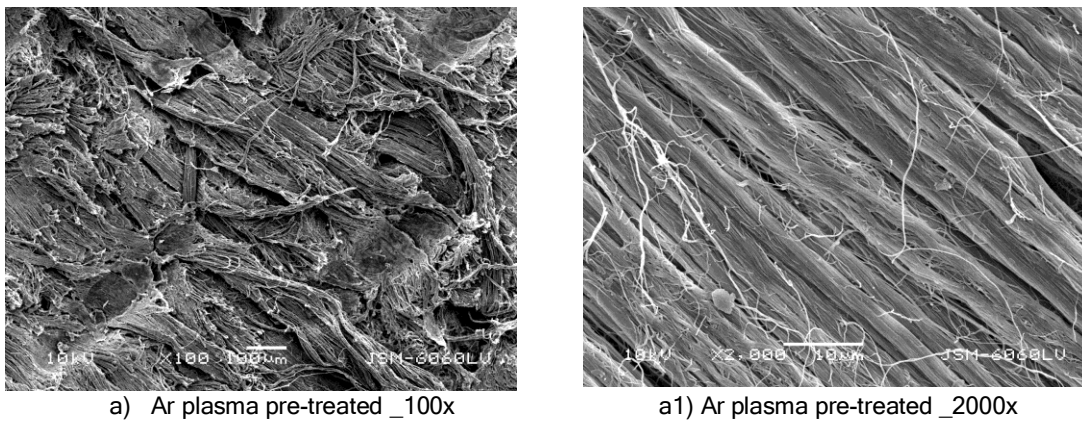

Figure 3: SEM micrographs of splitted leather samples; observed at 100x and 2000x magnifications: a), a1) - O₂ plasma pre-treatment; b), b1) - treatment with O₂/BTCA/CH.



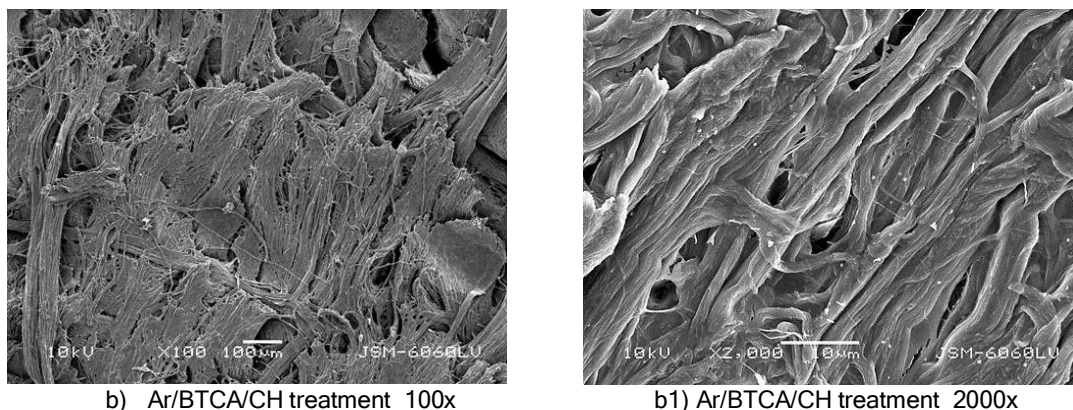

Figure 4: SEM micrographs of splitted leather samples; observed at 100x and 2000x magnifications: a), a1) - Ar plasma pre-treatment; b), b1) - treatment with O₂/BTCA/CH.

3.2 Hydrophilicity

Table 3: Water absorption of the leather surface after pre-treatments

Leather sample – pre-treatments		t [s]	Evaluation
chrome tanned splitted leather	untreated	280.0	hydrophobic
	O ₂ plasma	8.6	hydrophilic
	Ar plasma	1.4	hydrophilic

According to the results of water absorption (Table 3), plasma pre-treatments carried out under tested conditions resulted in an increase of hydrophilicity of the leather sample. These changes can be attributed to changes of the collagen fibers surface during plasma pre-treatments. Plasma-activated species bombard the surface with active species, which react with the surface and cause etching and ablation of the surface that results in the increases surface micro-roughness, and finally could improve wetting of the sample.

3.3 Results of permeability of alkaline sweat solution

The test results expressed as the change of sample weight, Δm [%], the proportion of permeable sweat solution through the sample into the environment was expressed as the difference between the initial volume and the residual volume, ΔV [%], and are shown in Table 4.

Table 4: Permeability of alkaline sweat solution of untreated and pre-treated samples

Leather sample – pre-treatments		m ₁ [g]	m ₂ [g]	Δm [%]	P _{8h} [g]	V _{8h} [ml]	ΔV [%]
chrome tanned splitted leather	untreated	6.7249	6.9309	3.06	0.2060	26.9	-32.75
	O ₂ plasma	6.7190	7.1283	6.09	0.4093	26.4	-34.00
	Ar plasma	6.1415	6.5336	6.38	0.3921	25.0	-37.50

m₁- sample weight (g); m₂ - sample weight after treatment with sweat solution (g); P_{8h} (m₂ - m₁) - sweat solution permeability through sample after 8 hours of treatment (g); V_{8h} - volume of residual sweat solution (ml). Initial amount of sweat solution volume V₀ (ml) = 40 ml.

Based on the results presented in Table 4, it can be concluded that the weight of leather samples increases over a period of 8 hours, and at the same time the permeability of the sweat solution through the structure of the pre-treated samples was increased, compared to the untreated one. Trend of increasing the ability to absorb and release the solution of sweat of pre-treated samples into the environment is evident.

3.4 Antibacterial activity against selected bacteria

The results of antimicrobial efficacy of untreated and treated leather samples against specified bacteria *Staphylococcus aureus* and *Klebsiella pneumoniae* are shown in Table 5. and Figure 4.

Table 5. Antibacterial activity of untreated and plasma pre-treated leather samples

Leather sample – treatment		Growth under the specimen	Assessment*
<i>Staphylococcus aureus</i>			
	untreated	Slight	Limit of efficacy

chrome tanned splitted leather	O ₂ /BTCA/CH	None	Good effect
	Ar/BTCA/CH	None	Good effect
<i>Klebsiella pneumoniae</i>			
chrome tanned splitted leather	untreated	None	Good effect
	O ₂ /BTCA/CH	None	Good effect
	Ar/BTCA/CH	None	Good effect

^aAssessment is based on ISO 20 645:2004 - "Determination of antibacterial activity - Agar diffusion plate test", where "good effect" is described as "no growth" under the specimen and "limit of efficacy" as "slight growth (only some restricted colonies or growth nearly totally suppressed)" under the specimen.

Considering the obtained results, the sample treated with O₂ or Ar/BTCA/CH shows a good effect against *S. aureus* bacteria. Untreated chromium tanned cleaved leather, obtained a slight growth of bacteria, which indicates a limit of antimicrobial efficacy, which is after treatments manifested (although there is no zone of inhibition) by inhibition of bacteria below the sample and indicates a good antimicrobial effect. The lack of an inhibition zone can be aggravated by the specific fibrillary structure of the leather surface, which can act as barrier to the better contact of bacteria and antimicrobial agent.

4. Conclusions

The following conclusions are proposed:

- pre-treatment conditions with O₂ and Ar plasma are optimized; the ability to absorb water increase after pre-treatments. Achieving a higher level of hydrophilicity is important for wearing comfort due to the change in liquid moisture of the leather product;
- morphological changes of leather after plasma pre-treatment analysed with SEM microscope indicate on higher binding of collagen fibers into bundles, which can affect on better transport of water from the surface through the structure and into the environment;
- the results of the permeability of the alkaline sweat solution indicate on a trend of increasing absorption capacity, and the transfer of the sweat solution through the samples treated with plasma;
- satisfactory antimicrobial efficacy of the tested samples against the selected bacteria was achieved after the performed treatments.

ACKNOWLEDGEMENTS

This work has been fully supported by the Croatian Science Foundation under the project (IP-2016-06-5278). Work (SEM analysis) was also financed by Slovenian Finance Agency, Slovenia (Infrastructure Centre RIC UL-NTF).

References

- [1] Li, Z. et al.: Mechanical behaviour of natural cow leather in tension, *Acta Mechanica Solida Sinica*, **22** (2009) 1, 37- 44, ISSN 0894-9166.
- [2] Akalović, J. et al.: Propusnost vodene pare govede kože za izradu profesionalne obuće, *Koža & obuća*, **67** (2018) 6-11, ISSN 1849-9767.
- [3] Štěpánová, V. et al.: Surface modification of natural leather using diffuse ambient air plasma, *International Journal of Adhesion and Adhesives*, **77** (2017) 198-203, ISSN 01437496.
- [4] Herman F.M.: *Encyclopedia of polymer science and technology*, J. Wiley & Sons ISBN 978-1-118-63389-2, (2011).
- [5] Basil-Jones M.M. et al.: Collagen fibril orientation in ovine and bovine leather affects strength: A small angle X-ray scattering (SAXS) study, *Journal of Agricultural and Food Chemistry*, **59** (2011) 9972-9979, ISSN 1520-5118.
- [6] Kaygusuz, M. et al.: Modification of Leather Surface with Atmospheric Pressure Plasma and Nano-Finishing, *Polymer-Plastics Technology and Engineering*, **57** (2018) 4, 260-268, ISSN 2574-0881.

Authors:

Assoc. prof. Sanja ERCEGOVIĆ RAŽIĆ, PhD. (corresponding author)
 Jadranka AKALOVIĆ, dipl. ing.; Jelena PERAN, mag.ing.techn.text. PhD student and Katarina IŠTEF, mag.ing.techn.text.
 University of Zagreb Faculty of Textile Technology
 Prilaz baruna Filipovića 28a, 10 000 Zagreb, Croatia
 Phone: +(385) (01) 3712 523 Fax: +(385) (01) 3712 577 E-mail:sanja.ercegovic@tff.unizg.hr
 Phone: +(385) (01) 3712 500 E-mail:jadranka.akalovic@tff.unizg.hr

Assist. prof. Tomislav IVANKOVIĆ
 University of Zagreb Faculty of Science
 Rooseveltov trg 6, 10 000 Zagreb, Croatia
 Phone: +(385) (01) 6189 712 Fax: +(385) (01) 4826 260 E-mail: tomislav.ivankovic@biol.pmf.hr

SYNTHETIZED CORN STARCH - ENVIRONMENTALLY ACCEPTABLE FOR COTTON WARP SIZING

Suzana ĐORĐEVIĆ; Dragan ĐORĐEVIĆ; Stana KOVAČEVIĆ & Ivana SCHWARZ

Abstract: This paper investigates newly developed synthesized corn starch for the sizing process, as an environmentally-friendly product used for cotton yarn sizing. The development of such newly synthesized natural starch led to a decrease in its molar mass, which made it easier to dissolve and thus easier to penetrate into the yarn structure and subsequently easier to remove from the fabric. Acrylamide (AA) and 2-hydroxyethyl methacrylate (HEMA) were used as monomers in the corn starch grafting process. The same initiators were used for the more efficient formation of grafted monomers on starch: azobisisobutyronitrile (AIBN), potassium persulfate (KPS) and benzoyl peroxide (BP). Research results and FTIR analysis showed that efficient new synthesized corn starch was obtained. The justification of usage of synthesized corn starch was confirmed, especially initiator AIBN in grafting process with 2-hydroxyethyl methacrylate (HEMA) on starch. Analysis of sized yarns found that coarser single as well as plied yarns adsorb or bind more sizing agents in all cases than finer yarns, which can be explained by a larger capacity in volume, looser structure and a smaller number of twist. After sizing process, the mechanical properties of the yarn changes, the breaking force increases, while the breaking elongation partially decreases. The micrographs of the yarns treated with the new starch have a more compact structure with fibres glued together, as well as great parallelism in the direction of the yarn longitudinal axis. Careful choice of the active agent synthesis process, a valid combination and optimal choice of temperature-time regime, can ensure the proper composition of sizing mass and processing method, which will ensure a high quality and uniform yarn sizing process. Based on the extensive conducted analyses, it can be concluded that there is a qualitative and environmental cost-effectiveness using the synthesized potato starch.

Keywords: synthesized potato starch; cotton yarn; FTIR spectrum; size pick-up; physical-mechanical properties.

1. Introduction

In fabric manufacturing the eternal question is: "Is sizing absolutely necessary?", because it represents a significant environmental and economic burden. The need for sizing is actually conditioned by the yarn, structural fabric parameters, weaving conditions and customer requirements on the quality of the finished fabric. The complexity of the sizing process is reflected in a number of parameters that relate to the properties of sizing agents, yarns, sizing and weaving machines, and optimizing size pick-up, which requires extremely complex and thorough research. Comprehensive research requires a broader knowledge of textile technology, chemistry, ecology, development and application of electronic controls and monitoring of many parameters in the sizing and weaving process. It is necessary to know how to detect a problem and to solve it in a short time. This points to the need for teamwork and research by experts of various profiles. The final goal of sizing is actually to reduce the number of breaks and the occurrence of deformations of warp threads in the weaving process, thereby increasing the quality of the fabrics and the utilization of the looms [1-3]. Improvements in the sizing process are reflected primarily in the development and application of new sizing agents, all with the aim of achieving a more economical, efficient and environmentally friendly product [4, 5]. In the beginning stages of sizing natural starches such as corn, potatoes, wheat starch and the like were used. Their disadvantage was the size of molecules that could not easily penetrate through the interstices of threads, viscosity instability when changing the temperature, the formation of a rigid film on the thread surface, reduction of thread elasticity, rapid decay, occurrence of gelatinization, creation of foam in the sizing box, non-uniform size pick-up, starch removal in the weaving process, multiple yarn breaks, desizing with microorganisms, etc. [6-8]. Modification of natural starches reduces or almost eliminates the aforementioned disadvantages. As environmentally friendly products, it is necessary to strive to gradually replace fully synthetic sizes based on polyvinyl alcohol (PVA), **carboxymethyl** cellulose (CMC), polyacrylate (PA) and other synthetic agents used today for the sizing process [9-11]. The goals of this research are primarily to create adequate, environmentally friendly and productive sizing agents for sizing warp threads. By graft-copolymerization monomers are grafted onto shorter starch macromolecules, creating lateral shorter or longer branches on the main chain, thus forming a product for a more efficient use in yarn processing. Since HEMA grafting has not been applied to corn starch in the sizing process so far, this research has this goal in mind. The sizing process was performed on structurally different cotton yarns (single or double) using different recipes of sizing agents, with the aim of

finding the best combinations that will show the most effective results under practical conditions on the loom. These studies are based on the fact that newly developed sizing agents require a new approach and a new technological organization in the process of sizing cotton yarns, which under practical conditions on the loom will show the most efficient results.

2. Experimental part

2.1 Materials

Ring-spun single cotton yarns with counts of 20 tex and 30 tex (701 twists/m) and ply yarns with counts of 20x2 tex and 30x2 tex (324 twists/m) were used for testing. Cotton fibers were spun into a yarn 27 to 28 mm thick and 4.5 μm in diameter, and they were supplied from Egypt.

For the purpose of this study, corn starch, hydrochloric acid (HCl), ethyl alcohol (C₂H₅O) and sodium carbonate (Na₂CO₃) were used. As initiators of the grafting process azobisisobutyronitrile (AIBN) i.e. (2,2'-azobis (2-methylpropionitrile) 99%, potassium persulfate (KPS) K₂S₂O₈ and benzoyl peroxide (BP) (C₆H₅CO)₂O₂ were used. As monomers of the grafting process acrylamide (AA) C₃H₅NO and 2-hydroxy-ethyl methacrylate (HEMA) C₆H₁₀O₃ were used.

2.2 Sizing machines

The yarn sizing process was performed on an innovative laboratory sizing machine adapted to industrial conditions, constructed on University of Zagreb Faculty of Textile Technology (Figure 1). The following parameters were monitored and kept constant: The optimization refers to the definition of the particular parameters of the laboratory sizing machine: thread tension at the entry of the size box (42 cN), temperature of the size in the size box (85°C), sizing speed (3m/min), pressure on the last pair of the squeezing rollers (1.5 N/cm²), drying temperature (110-130°C) and outlet humidity of threads (5.5%).

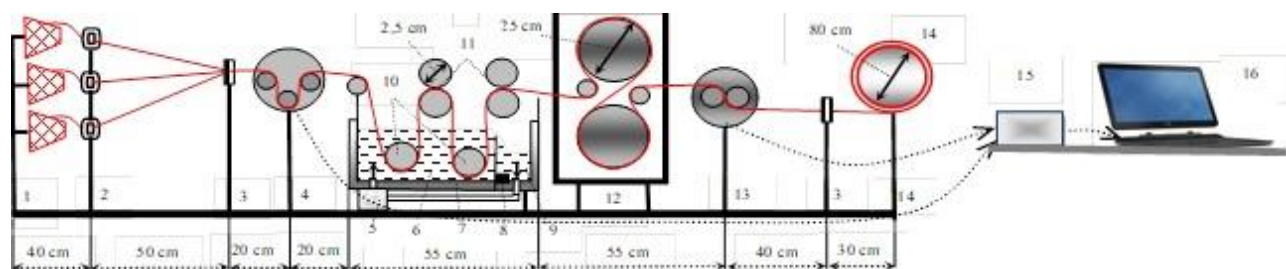

Figure 1: Laboratory sizing machines, 1 - bobbin creel, 2 - thread guides and brakes, 3 - comb, 4 - tensiometer, 5 - pump, 6 - size box, 7 - double wall of the box with heater, 8 - thermostat, 9 - support box, 10 - dipping rollers, 11 - extrusion size rollers, 12 - contact dryer, 13 - moisture tester, 14 - sized yarn winder, 15 - AD converter. 16 - computer

2.3 Test methods

Sizing was performed with concentrations of 1%, 3% and 5% of sizing agents for the ply yarn and with concentrations of 5%, 10% and 15% of sizing agents for the single yarn. The following tests were carried out:

- the FTIR analysis - potassium bromide technique, spectrophotometer BOMEM Hartmann & Braun MB-Series in the range of wavelengths 4000-400 cm⁻¹
- size pick-up (D) on the yarn was obtained using the mass procedure according to equation

$$D = \frac{m_1 - m_0}{m_0} \times 100 (\%) \quad (1)$$

where: m_1 - yarn mass after sizing (g); m_0 - yarn mass before sizing (g),

- breaking force and elongation at break of the yarn tested on the Textechno STATIMAT M tensile tester according to standard ISO 2062
- Scanning Electron Microscopy (SEM) - JEOL JSM - 6610LV microscope.

3. Results and discussion

3.1. Starch modification

For the purposes of this study corn starch was used for hydrolysis and afterwards for grafting of various monomers. Starch hydrolysis was carried out to reduce the molar mass, which implies easier solubility without bulky agglomerates in the solution, easier penetration into the yarn structure and later easier removal from the fabric. Monomers were grafted onto shorter starch macromolecules when they form lateral shorter or longer branches on the main chain, resulting in a product for more successful use in yarn processing. Characterization of all monomers grafted onto hydrolyzed starch was performed. Table 1 shows some parameters indicating the efficiency of hydrolysis and monomer grafting onto starch depending on the type of initiator and the FTIR spectra of hydrolyzed and grafted starch.

Table 1: FTIR spectra of hydrolyzed and grafted starch by type of graft initiators

Samples		PHS (%)	PriK (%)	PrpK (%)	PEK (%)	KMP (%)
AA grafted starch	HS	76.92	-	-	-	-
	HS-AA-AIBN	-	79.33 ^a	19.00 ^a	38.31 ^a	99.20 ^b
	HS-AA-KPS	-	80.0 ^a	20.00 ^a	40.65 ^a	98.40 ^b
	HS-AA-BPO	-	81.33	22.00	44.49	98.90
HEMA grafted starch	HS-HEMA-AIBN	-	84.67	27.00	54.88	98.40
	HS-HEMA-KPS	-	81.33 ^a	22.00 ^a	44.81 ^a	98.20 ^b
	HS-HEMA-BPO	-	83.33 ^a	25.00 ^a	50.71 ^a	98.60 ^b
	FTIR spectra of the hydrolyzed and grafted starch					
FTIR spectra of the hydrolyzed and grafted starch						

where: PHS – yield of starch hydrolysis (%), PriK – graft yield (%), PrpK – grafting percentage (%), PEK -percentage of graft efficacy (%), KMP – conversion of monomer to polymer (%), ^a- for significance level of 0.05, mean value of the group sample is significantly different from the hypothetical mean value, ^b- for significance level of 0.05, mean value of the group sample is not significantly different from the hypothetical mean value, HS - hydrolyzed starch, KPS - potassium persulfate, AIBN - azobisisobutyronitrile, BP - benzoyl peroxide, AA - acrylamide, HEMA - 2-hydroxyethyl methacrylate

It can be observed from the FTIR spectrum of hydrolyzed starch that a wide peak occurs at about 3400 cm⁻¹ originating from O-H valence vibrations, as well as a lower peak at 2928 cm⁻¹ attributed to C-H valence vibrations. Wave numbers at about 1151, 1081 and 1020 cm⁻¹ describe the C-O-C stretch (starch triplet) and the peak band at 1640 cm⁻¹ originates from water molecules [12].

In the case of the starch grafted with acrylamide, the OH valence band of the starch hydroxyl group and the NH valence band of the poly (acrylamide) amide group overlap and result in a peak at 3730 cm⁻¹ resting on a peak occurring at about 3670 cm⁻¹. Peaks at about 570, 764, 860 cm⁻¹ (vibrations of -OH groups) in grafted starch change in intensity and shape, indicating that OH starch groups changed during the reaction. Thus, the presence of these additional peaks in the case of grafted starch in relation to hydrolyzed starch confirms the successful grafting of poly (acrylamide) chains onto starch [13].

The following monomer bands were observed in the FTIR spectrum of starch with HEMA grafting initiator: C-O valence vibrations at 1295 and 1170 cm⁻¹, C = C valence vibrations of double bonds at 1650 cm⁻¹, C-H bond vibrations: ν_s (CH₃) at 2925 cm⁻¹, and OH group valence vibrations at about 3420 cm⁻¹. Vibrations of the ring of the aromatic core were observed at 1600, 1505 and 1470 cm⁻¹. Asymmetric and symmetrical stretching vibrations of the methyl group were observed at 1455 and 1380 cm⁻¹ [14].

3.2 Size pick-up

Increasing the sizing agent concentration expectedly increased the mass of the yarn sample or the size pick-up (Figure 2). The size pick-up of the copolymer or grafted starch was slightly higher than that of hydrolyzed starch at the same concentration. It can be claimed that HS-AA starch with BP initiator shows a higher size pick-up compared to HS-HEMA starch with AIBN initiator. The plied yarn adsorbs or bonds more sizing agent in relation to finer yarns which is associated with higher concentration, higher volume, looser structure (yarn porosity) and with lower yarn twist. The size of lower concentration penetrates the structure - yarn depth - more easily, forms adhesive layers bonding the fibers together, while higher viscosity reduces the inner presence and increases surface pick-up [15].

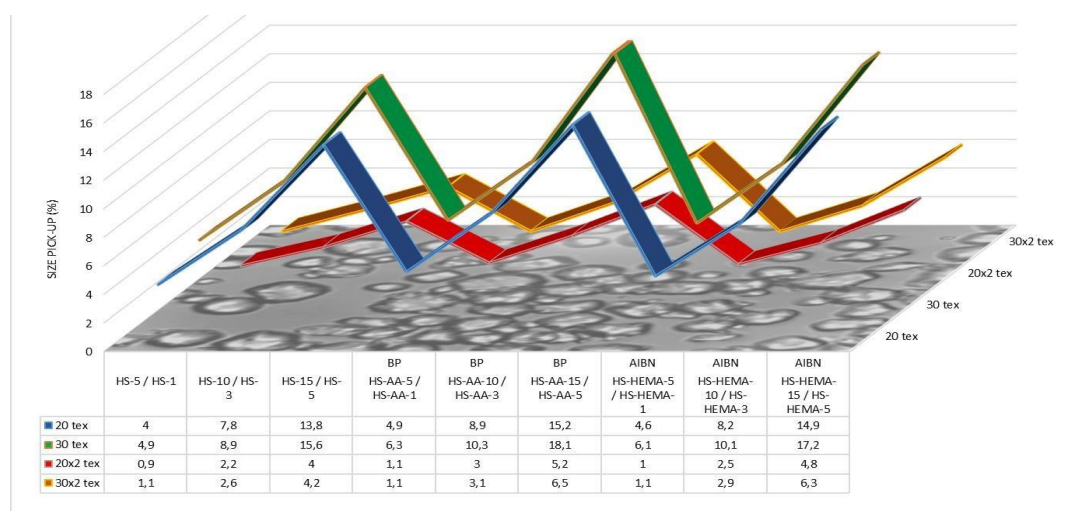

Figure 2: Size pick-up on the yarn sized with hydrolyzed starch grafted with AA and BP initiator and with hydrolyzed starch grafted with HEMA and AIBN initiator, meaning of designations: HS-5/HS-1 → HS - hydrolyzed starch, 5 - concentration (5%), 1 - concentration (1%);

3.3 Breaking force and elongation at break

Table 2: Breaking forces and elongations at break of the yarn per counts, monomers of starch and concentrations

Starch designation	Yarn count															
	20 tex				30 tex				20×2 tex				30×2 tex			
	F ₂₀ (cN)	CV (%)	ε ₂₀ (%)	CV (%)	F ₃₀ (cN)	CV (%)	ε ₃₀ (%)	CV (%)	F _{20×2} (cN)	CV (%)	ε _{20×2} (%)	CV (%)	F _{30×2} (cN)	CV (%)	ε _{30×2} (%)	CV (%)
Before sizing	330	8.1	4.1	9.1	459	7.4	5.4	7.1	650	4.4	6.3	6.8	824	5.3	5.1	5.5
HS-5 / HS-1	349	9.2	2.9	8.8	478	6.6	3.8	6.5	665	4.8	5.5	7.5	835	4.5	4.6	6.2
HS-10 / HS-3	410	8.2	2.8	7.5	546	6.1	3.7	6.3	675	2.8	5.4	8.3	852	4.4	4.5	7.3
HS-15 / HS-5	445	7.8	2.7	7.9	574	7.2	3.5	5.5	688	5.2	5.3	9.6	877	3.5	4.3	5.8
HS-AA-5 / HS-AA-1	374	7.6	3.1	7.5	486	7.5	4.1	4.7	665	4.6	5.9	8.0	838	6.4	4.7	5.2
HS-AA-10 / HS-AA-3	436	7.9	3.0	7.8	555	7.3	4.1	3.9	686	4.1	5.7	7.3	839	5.4	4.5	8.0
HS-AA-15 / HS-AA-5	450	7.8	2.9	7.8	586	7.1	3.9	5.2	695	4.6	5.6	5.4	880	8.3	4.4	8.2
HS-HEMA-5 / HS-HEMA-1	385	8.5	3.5	8.8	497	8.1	4.5	5.7	671	6.0	6.1	10.2	845	4.7	4.9	10.0
HS-HEMA-10 / HS-HEMA-3	443	8.2	3.4	8.1	586	8.1	4.4	4.6	687	4.8	6.0	9.6	860	3.8	4.9	6.5
HS-HEMA-15 / HS-HEMA-5	467	7.4	3.4	8.2	601	8.2	4.3	7.3	705	3.8	5.8	6.7	903	5.4	4.7	9.8

where: $F_{20,30,20 \times 2,30 \times 2}$ - breaking force according to yarn designations (cN), $\epsilon_{20,30,20 \times 2,30 \times 2}$ - elongation at break according to yarn designations (%), CV - variation coefficient (%)

One of the tasks of the sizing process is that the breaking forces of the warp yarns are “sufficiently” higher than the maximum warp stretching in the weaving process. The test results of some mechanical properties, Table 2, reveal that after sizing there was an increase in the breaking forces of all the analyzed yarns, meaning that one of the basic tasks of the warp sizing processes was realized.

Starch hydrolysis resulted in an increase in breaking forces in all samples. Grafting of starch resulted in an additional increase in breaking forces. The HEMA grafted starch achieves better results than AA in terms of breaking forces, for all types of yarns, which indicates its more uniform distribution and appropriate adhesion both on the surface and in the inside of the yarn. Due to a higher concentration level, the breaking force increases in the single yarn (concentrations 5, 10, and 15%) and in the plied yarn (concentrations 1, 3, and 5%), but the elongation at break mostly decreased. The consequence of sizing is a reduction of elongation at break for all yarns, probably because the yarn became encapsulated and trapped by the size coating, making it less elastic. This reduction in elongation at break yarn is a drawback of sizing, whereby it is extremely significant that result variations are as low as possible which is manifested in this study. It is interesting to mention that the plied yarn retained a high percentage of elongation, which is convenient for practical use.

3.4. Electron microscopy

Before sizing the yarn contains fibers that are not sufficiently interconnected as a whole, resulting in poorer mechanical properties, pronounced unevenness and hairiness (Figure 3a). By sizing the yarn structure becomes uniform, full and compact (Figure 3b). Sizing agents fill the interspace of the fibers, glue them together, direct them along the length, create a smooth surface layer that protects the thread from abrasion, connects all the fibers into one thread, and thus act together as one solid unit.

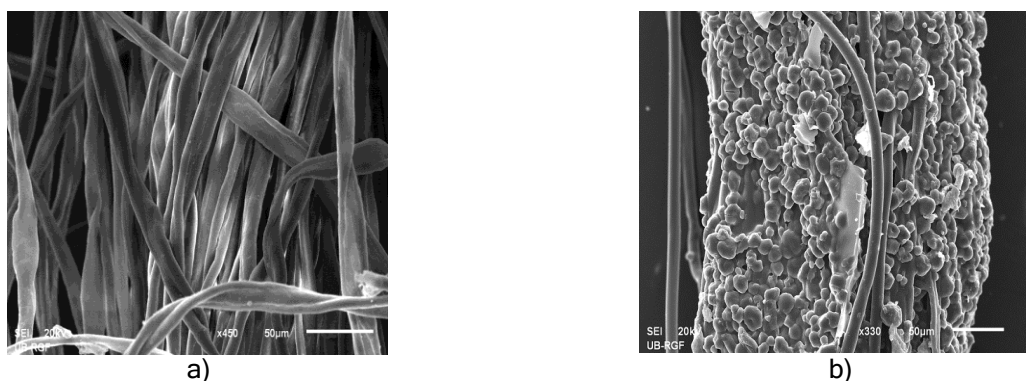

Figure 3: Micrographs of 20 tex yarn: a) unsized yarn, b) sized yarn

4. Conclusion

On the basis of the research methods of grafted hydrolyzed corn starch and its use for sizing cotton yarns, the following can be concluded: A higher size concentration resulted in a higher size pick-up, containing hydrolyzed and grafted starch. A greater effect of concentration was observed in starch with AA initiator. The plied and coarser yarn had a higher size pick-up than the single and finer yarn. All the samples of the sized yarn had a higher breaking force. Starch hydrolysis caused increased breaking forces. Grafting of vinyl monomers depends on the initiator used. The HEMA initiator gave better results than the AA initiator. The consequence of sizing is a reduction of elongation at break for all yarns. By increasing breaking forces, elongation at break also increased. The most important measurements in the synthesis of starch, the yield of hydrolysis and grafting, the percentage and efficiency of grafting, the conversion of monomers into polymer, as well as FTIR analysis confirmed that this is a newly synthesized starch that significantly improved the properties of the yarn in warp sizing. The analysis of the sized yarn shows that synthesized starches gave good results in terms of increasing breaking force (20 tex: 5.76-41.52%; 30 tex: 4.14-30.94%; 20x2 tex: 2.31-8.46% and 30x2 tex: 1.33-9.59%), and yarn elongation at break decreased with sizing (20 tex: 14.63-34.15%, 30 tex: 16.67-35.19%; 20x2 tex: 3.17-15.87% and 30x2 tex: 3.92-15.69%). By carefully selecting the synthesis procedure of the active agent as well as by a valid combination of modified sizing agents, it is possible to obtain an appropriate size concentration that ensures optimal, high-quality and uniform yarn sizing. Based on the analyses carried out, it is possible to conclude that it is economically, qualitatively and cost-effectively justifiable to return natural

starches into the sizing process, but only by synthesizing and grafting with appropriate initiators, which significantly improve their properties.

Acknowledgements

This work has been fully supported by Croatian Science Foundation (HRZZ) under the projects IP-2018-01-3170 Multifunctional woven composites for thermal protective clothing.

References

- [1] Đorđević S.: Synthesis of starch-based derivatives and their application in processes of yarn sizing, Doctoral Dissertation, University of Niš, Faculty of Technology in Leskovac, Leskovac, 2014.
- [2] Maatoug, S.; Ladhari, N. & Sakli, F.: Evaluation of the weavability of sized cotton warps, *Autex Research Journal*, Vol. 8 (2007) No. 4, pp 239-244 (2007) 239-244, ISSN 2456-0235
- [3] Stegmaier, T., et. All: A sizing agent in fabric production - development and ecological evaluation, *Clean – Soil Air Water*, Vol 36 (2008) No. 3, pp 279-286, ISSN 1863-0669
- [4] Sun, S., et. all, Eco-friendly sizing technology of cotton yarns with He/O₂ atmospheric pressure plasma treatment and green sizing recipes, *Textile Research Journal*, Vol. 83 (2013) No. 20, pp. 2177-2190, ISSN 0040-5175. online ISSN 1746-7748
- [5] Utrilla-Coello, R. G., et. All: Acid hydrolysis of native corn starch: Morphology, crystallinity, rheological and thermal properties, *Carbohydrate Polymers*, Vol. 103 (2014) No. 1, pp. 596-602, ISSN 0144-8617
- [6] Zhu, Z. & Cao S.: Modifications to improve the adhesion of crosslinked starch sizes to fiber substrates, *Textile Research Journal*, Vol. 74 (2004) No. 3, pp 253-258, ISSN 0040-5175. online ISSN 1746-7748
- [7] Hebeish, A., et. all, Innovative starch derivatives as textile auxiliaries for application in sizing, finishing and flocculation, *Starch/Stärke*, Vol. 60 (2008) No. 2, pp. 97-109, ISSN 0038-9056
- [8] Z., Zhu & Xiong, Z.: Effect of starch/SiO₂ nanoparticle blends on the adhesion of starch to fibers for warp sizing, *AATCC Review*, Vol. 8 (2008) No. 10, pp. 45-48, ISSN 1532-8813
- [9] Kovačević S., et. All: Synthesized Potato Starch-A New Eco Sizing Agent for Cotton Yarns, *Polymers*, Vol. 11 (2019) No. 5, pp. 908-930 online, ISSN 2073-4360
- [10] Djordjević S. et. all, Sizing process of cotton yarn by size from a copolymer of methacrylic acid and hydrolyzed potato starch, *Textile research journal*, Vol. 89 (2019), No. 17, pp. 3457-3465, ISSN 0040-5175. online ISSN 1746-7748
- [11] Kovačević, S.; Đorđević, S. & Đorđević, D.: Natural Modified Starch and Synthetic Sizes in Function of Characteristics of Sized Yarn, *Fibres & Textiles in Eastern Europe*, Vol. 24 (2016) No.1, ISSN 1230-3666
- [12] Mostafa, Kh. M.: Graft polymerization of methacrylic acid on starch and hydrolyzed starches, *Polymer degradation and stability*, Vol. 50 (1995) No. 2, pp. 189-194, ISSN 0141-3910
- [13] Carvalho, A. J. F.; Curvelo, A. A. S. & Gandini A.: Surface chemical modification of thermoplastic starch: reactions with isocyanates, epoxy functions and stearyl chloride, *Industrial Crops and Products*, Vol. 21 (2005) No. 3, pp. 331-336, ISSN 0926-6690
- [14] Rahman, L., et. All: Graft Copolymerization of methyl acrylate onto sago starch using ceric ammonium nitrate as an initiator, *Journal of Applied Polymer Science*, Vol. 76 (2000) No. 3, pp. 516-523, ISSN 0021-8995, online ISSN 1097-4628
- [15] Jenkins, P. J. & Donald, A. M.: The effect of acid hydrolysis on native starch granule structure, *Starch/Stärke*, Vol. 49, (1997) No. 7/8, pp. 262-267, ISSN 0038-9056

Prof. Suzana ĐORĐEVIĆ, Ph.D. (corresponding author)
Technological and Artistic Professional School Leskovac, Textile Department
16.000 Leskovac, Serbia
Phone: +(381) (16) 242-569 Fax: +(381) (16) 233 911 E-mail: szn971@yahoo.com

Prof. Dragan ĐORĐEVIĆ, Ph.D.
University of Nis, Faculty of Technology, Textile Department, Bulevar Oslobođenja 124
16.000 Leskovac, Serbia
Phone: +(381) (16) 247 203 Fax: +(381) (16) 242 859 E-mail: drdrag64@yahoo.com

Prof. Stana KOVAČEVIĆ, Ph.D.
University of Zagreb, Faculty of Textile Technology, Department of Textile Design and Management
Prilaz baruna Filipovića 28a, 10 000 Zagreb, Croatia
Phone: +(385) (1) 37 12 575 Fax: +(385) (1) 37 12 500 E-mail: stana.kovacevic@ttf.hr

Assis. Prof. Ivana Schwarz, Ph.D.
University of Zagreb, Faculty of Textile Technology, Department of Textile Design and Management
Prilaz baruna Filipovića 28a, 10 000 Zagreb, Croatia
Phone: +(385) (1) 3712 574 Fax: +(385) (1) 37 12 500 E-mail: ivana.schwarz@ttf.hr

CHANGES IN FABRIC ELASTICITY IN RESPONSE TO STERILIZATION WITH OZONE

Uwe REISCHL & Budimir MIJOVIC

Abstract: *A limited supply of personal protective equipment (PPE) in the current COVID-19 pandemic has led to frequent unsafe reuse of protective clothing by healthcare workers and the public. The application of ozone gas to sterilize PPEs before reuse has been proposed. However, the potential damage caused to the fabric materials has not been reported in the scientific literature. A study was conducted to investigate changes in the elasticity of eight combinations of fabric materials exposed to ozone gas under controlled laboratory conditions. No evidence of material degradation was found. The results of this study suggest that the use of ozone gas to sterilize PPEs can be effective and may allow persons to reuse their equipment multiple times.*
Keywords: *Ozone sterilization, PPE reuse, Fabric elasticity*

1. Introduction

The COVID-19 pandemic has created global shortages in the supply of personal protective equipment needed by healthcare workers and the public to protect against the transmission of the corona virus. While currently available equipment is intended for single-use only, safe and effective disinfection with ozone gas may allow such equipment to be reused multiple times. This approach may be able to address the shortage of available personal protective equipment in the future.

Ozone gas is an effective disinfectant that kills bacteria and viruses upon contact [1-3]. Ozone is a highly reactive gas that can reach poorly accessible surfaces and spaces other disinfection methods cannot reach. Ozone gas does not produce harmful residues since residual ozone always converts back to oxygen. Therefore, this method can provide an effective alternative to sterilizing personal protective equipment against the COVID-19 virus. However, there are questions regarding the potential damage that high concentrations of ozone may inflict on textile materials [4,5]. Elasticity characteristics reflect the structural integrity of the material and damage to the material can change its elasticity [6,7]. To investigate this matter further, a pilot study was conducted to evaluate the impact of ozone exposure on changes in fabric elasticity.

2. Methods and Procedures

2.1. Fabric Samples

Eight types of fabric were evaluated in this study. Each sample was 20 mm wide and 100 mm long. All samples were obtained from previously used clothing. The materials consisted of various combinations of Polyester, Cotton, Rayon, Spandex, Nylon and Silk. A summary of the composition of the samples is presented in Table 1.

2.2. Elasticity Measurements

Incremental increases in tensile force ranging from 0 to 323 grams were applied to measure changes in elasticity (stretch). Fabric stretch was measured using two reference markers placed on each sample prior to testing. The distance between the two reference markers was 60 mm. The design of the apparatus used in this study is shown in Figure 1.

2.3. Ozone Exposure

Fabric samples were placed into an enclosed 20-Liter chamber and exposed to an ozone concentration of 17 ppm for a total duration of 120 minutes. The exposure chamber design is illustrated in Figure 2.

Table 1: Composition of fabric samples tested for elasticity changes after ozone exposure

Sample #	Fabric Type	Composition
1	Polyester	95%
	Spandex	5%
2	Cotton	55%
	Rayon	10%
	Spandex	5%
3	Polyester	100%
4	Polyester	87%
	Rayon	10%
	Spandex	3%
5	Cotton	70%
	Rayon	30%
6	Nylon	100%
7	Silk	95%
	Spandex	5%
8	Cotton	100%

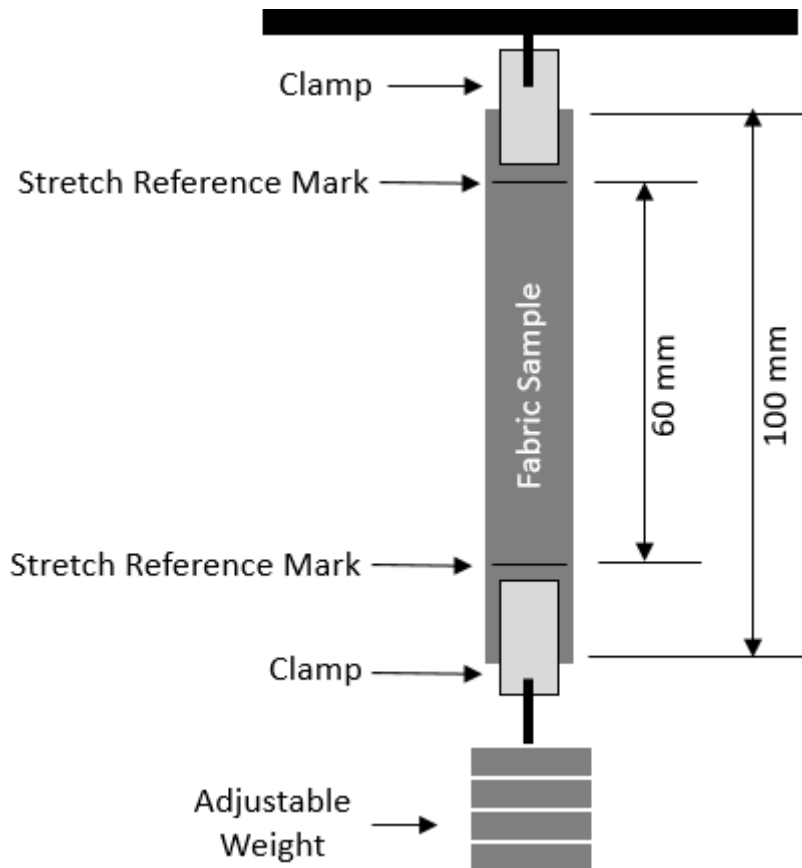

Figure 1: Test apparatus used for determining fabric elasticity (stretch) in response to controlled tensile forces.

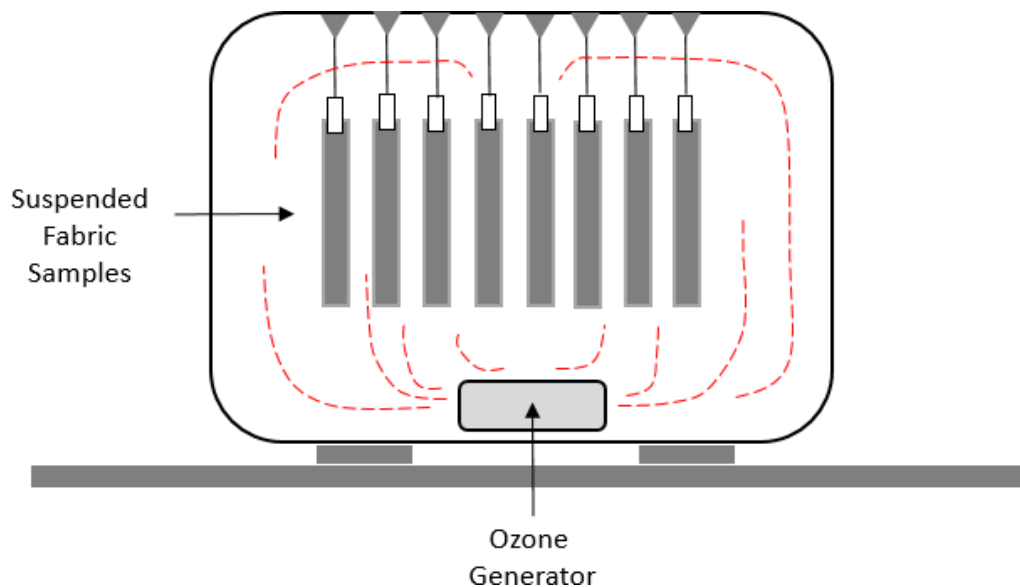

Figure 2: Illustration of exposure chamber design with internal placement of ozone generator and fabric samples

3. Results

Fabric stretch values obtained for the six tensile force conditions were compared to the references marked on each fabric sample prior to testing. The stretch value was then converted to a percentage (%) change relative to the non-stretched condition (0 force). Table 2 summarizes the “stretch” values obtained for fabric samples 1-4 under the “control” condition. Table 3 summarizes the “stretch” values obtained under the “control” condition for fabric samples 5-8.

Table 2: Stretch values obtained for samples 1-4 for the “control” condition.

Applied Tension	#1 95% Polyester	#2 55% Cotton	#3 100% Polyester	#4 87% Polyester
Force (g)	Stretch (%)	Stretch (%)	Stretch (%)	Stretch (%)
0	0	0	0	0
53	21	14	3	16
104	29	22	5	21
157	35	25	5	25
211	39	32	5	30
253	40	33	5	30
323	40	33	5	30

Table 3: Stretch values obtained for samples 5-8 for the “control” condition.

Applied Tension	#5 70% Cotton	#6 100% Nylon	#7 95% Silk	#8 100% Cotton
Force (g)	Stretch (%)	Stretch (%)	Stretch (%)	Stretch (%)
0	0	0	0	0
53	15	5	12	24
104	24	8	13	34
157	31	8	17	44
211	34	12	18	51
253	37	12	20	56
323	37	12	20	58

4. Analysis

The fabric samples evaluated before exposure to ozone exhibited normal stress/strain characteristics. The tensile forces applied to the samples did not exceed their elastic capacity. A complete return to the original conditions was observed. The stress/strain profile for fabric samples 1-4 are illustrated in Figure 3 and the stress/strain profile for fabric samples 5- 8 are illustrated in Figure 4.

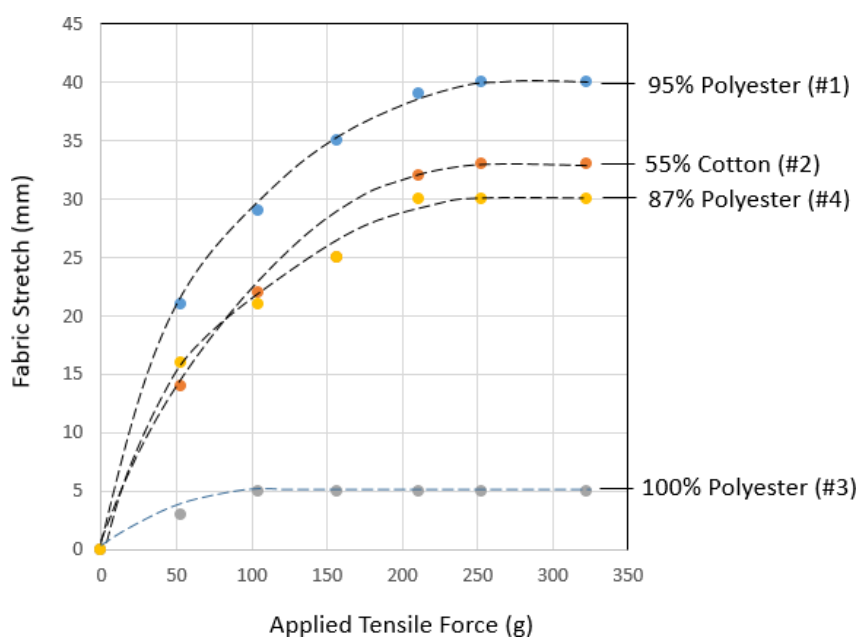

Figure 3: Stress/strain profile for fabric samples 1-4.

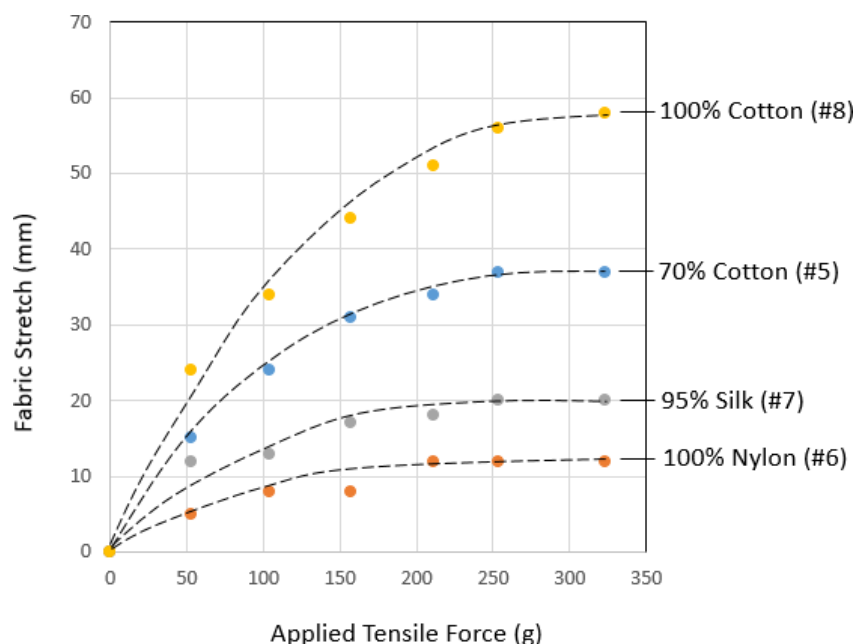

Figure 4: Stress/strain profile for fabric samples 5-8.

Comparison of the “control” stress/strain data with the post ozone exposure stress/strain data show no significant damaging effects on the fabric samples, i.e., no significant shifts in elasticity as illustrated in Table 3. The two-hour exposure period to ozone at a concentration of 17 ppm represents an “extreme” condition which is not needed to sterilize personal protective equipment. Therefore, with no observable degradation in the elastic properties of the fabric samples, the results suggest that disinfecting fabrics similar to those tested in this study, and not exposed to higher concentrations, can be done safely.

Table 3: Comparison of fabric stretch values between “control” condition and ozone exposure condition.

Fabric Sample #	Control	Post Ozone Exposure
	Fabric Stretch (%)	Fabric Stretch (%)
1	40	35
2	33	35
3	5	5
4	30	22
5	37	29
6	12	10
7	20	22
8	58	44
Avg.	29.4	25.3

5. Conclusion

The results suggest that fabrics similar in composition to those tested in this study can be exposed repeatedly to ozone gas concentrations up to 17 ppm for two hours without significant changes in elasticity. Ozone sterilization of personal protective clothing should, therefore, be considered a viable PPE sterilization strategy that can allow healthcare workers and the public in the future to reuse personal protective equipment safely.

References

- [1] Tseng, C.; Li, C.: Inactivation of Surface Viruses by Gaseous Ozone, *Journal of Environmental Health*, **70** (2008) 10, pp. 56-63, ISSN: 0022-0892
- [2] Li, C. S.; Wang, Y. C.: Surface Germicidal Effects of Ozone for Microorganisms, *AIHA Journal: a Journal for the Science of Occupational and Environmental Health and Safety*, **64** (2003) 4, pp. 533-537, ISSN: 15428117
- [3] Karpendale, M. T. F.; Freeber, J. K.: Ozone Inactivates HIV at Noncytotoxic concentrations, *Antiviral Research*, **16** (1991) 3, pp. 281-292, ISSN: 0166-3542
- [4] Perincek, S.; Duran, K.; Korlu, A. et al.: An investigation in the use of ozone gas in the bleaching of cotton fabrics, *Ozone Science and Engineering*, **29** (2007) 5, pp. 325-333, ISSN: 0191-9512
- [5] Prabakaran, M.; Rao J. V.; Nayar, R. et al.: A study on the advanced oxidation of a cotton fabric by ozone, *Coloration Technology*, **116** (2000) 3, pp. 83-86, ISSN: 1478-4408
- [6] Su, C. I.; Maa, M. C.; Yang, H. Y.: Structure and Performance of Elastic Core-Spun Yarn, *Textile Research Journal*, **74** (2004) 7, pp. 607-610, ISSN: 1746-7748
- [7] Gorjanc, S.; Bukosek, V.: The behavior of fabric with elastane yarn during stretching, *Fibers and Textiles in Eastern Europe*, **68** (2008) 3: pp. 63-68, ISSN: 1230-3666

Authors:

Prof. Uwe REISCHL, Ph.D. (corresponding author)
Boise State University
Department of Community and Environmental Health
1910 University Ave., Boise, Idaho 83725-1835

E-mail: ureisch@boisestate.edu

Prof. Budimir MIJOVIC, Ph.D.
University of Zagreb, Faculty of Textile Technology
Prilaz baruna Filipovića 28a, 10 000 Zagreb, Croatia
Phone: +(385) (1) 3712 557 Fax: +(385) (1) 3712 599

E-mail: budimir.mijovic@ttf.unizg.hr

THE INFLUENCE OF LIPASE SURFACE MODIFICATION TO POLYESTER CRYSTALLINITY AND ABSORBILITY

Anita TARBUK; Dragan ĐORĐEVIĆ; Sandra FLINČEC GRGAC; Marija KODRIĆ;
 Eva Magovac & Ivana ČORAK

Abstract: Poly(ethylene-terephthalate) (PET) fabric has small absorption due to high fibre crystallinity. The alkali hydrolysis and aminolysis, conventional surface modifications, are not eco-friendly. Therefore, the alternative methods have been researched, and the application of enzymes is one of them. In this paper the lipase surface modification of light PET satin woven fabric was performed and compared to alkali hydrolysed one. The degree of crystallinity was calculated from the absorption on 973 cm^{-1} and 1018 cm^{-1} measured on FTIR-ATR, Spectrum 100, PerkinElmer. The liquid moisture management properties: Wetting time, Absorption Rate, Maximum Wetted Radius, Spreading Speed, Accumulative One-way Transport Capability, and Overall (liquid) Moisture Management Capability were determined according to AATCC TM 195-2017 Liquid Moisture Management Properties of Textile Fabrics on Moisture Management Tester (MMT M290 by SDL Atlas). It has been showed that lipase treatment lowers the PET crystallinity from 29.65 to 24.73%, similar as alkali hydrolysis 24.90%. The MMT results showed better absorption, moisture management, indicating better comfort of such treated fabrics.

Keywords: poly(ethylene-terephthalate) (PET), lipase, hydrolysis, crystallinity, liquid moisture management

1. Introduction

Poly(ethylene-terephthalate) (PET) has extreme crystallinity, and consequently, small quantity of free active groups. Therefore, fabrics made of PET have small sorption of dyestuff and textile auxiliaries, which affect its comfort, so the surface modification is necessary. The conventional surface modifications, as alkali hydrolysis and aminolysis, are not eco-friendly, so the alternative methods have been researched [1-9]. Enzymatic hydrolysis is one of them (Figure 1.)

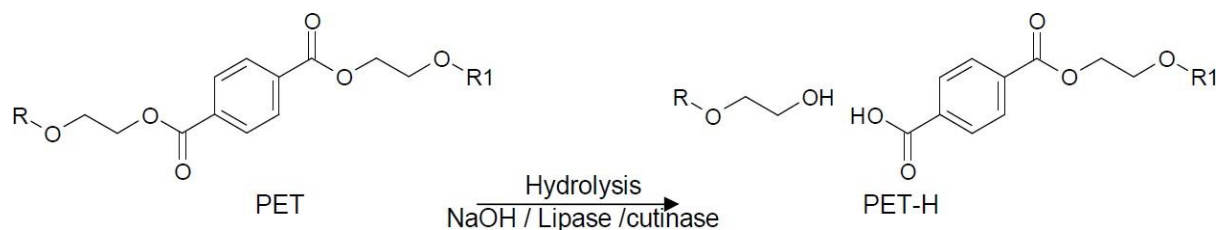

Figure 1: Hydrolysis of poly(ethylene terephthalate) [9]

Alkaline hydrolysis is topochemical saponification of polyester fibres which results in weight loss, reduced fibre diameter and strength. The effect of alkali hydrolysis of PET fabric is modification of its surface to achieve silk like material of improved comfort [2]. In practice the alkaline hydrolysis is done by a relatively concentrated aqueous sodium hydroxide solution at elevated temperature ($80\text{-}110^\circ\text{C}$) applying some cationic compounds as accelerators.

It was discovered that aliphatic-aromatic copolyesters and even aromatic polyesters can be attacked and modified by lipolytic enzymes. Reaction takes place in mild conditions, and because of the size of enzymes, reaction occurs on the fibre surface so that the main characteristic of the fibre remains unaltered. Enzymes active on PET substrates include various cutinases, lipases, and esterases [4-9].

Therefore, in this paper the lipase hydrolysis of light PET satin woven fabric was performed and compared to alkali hydrolysis.

2. Material and Methods

In this research light satin woven fabric of 100% PET (poly(ethylene-terephthalate)) with a surface mass of 100 g/m² was used. The fabric was woven of textured multifilament yarns which are consisted of delustered fibers with trilobal cross section in warp and circular cross section in weft, previously heat set. Fineness of the yarn was 50 dtex (16f). Surface of PET fabrics was modified by hydrolysis, by alkali and enzyme lipase. Labels, treatments and procedure are presented in Table 1.

Table 1: Labels, treatments and procedures of PET fabrics

Label	Treatment / surface modification procedure
PET	Untreated PET fabric
PET-H	Alkali hydrolysis: PET fabric was treated in 1.5 mol/l NaOH for 60 min at 100 °C in horizontal stirrer at 110 rpm (LR 1:50), until the theoretical [3] weight loss of 20 % was accomplished. It was rinsed and neutralized using 1wt % HCl
PET-L	Enzyme treatment: PET fabric was treated in 50 ml/l lipase from <i>Penicillium roqueforti</i> by batch wise method (LR 1:50) at pH 7, 40 °C for 180 min in horizontal stirrer at 110 rpm. Afterwards, temperature was elevated to 60 °C for enzyme degradation, followed by rinsing and air drying.

The hydrolyzed PET fabrics were analyzed by FTIR spectrometer (PerkinElmer, software Spectrum 100). 16 scans at a resolution of 4 cm⁻¹ were recorded for each sample between 1100 cm⁻¹ and 850 cm⁻¹. The degree of crystallinity (C) was calculated from the absorption on 973 cm⁻¹ and 1018 cm⁻¹ according to [10]:

$$C = \frac{A_{973}}{A_{1018}} \cdot 100 \% \quad (1)$$

where A_{973} and A_{1018} are corrected absorption maximum at on 973 cm⁻¹ and 1018 cm⁻¹, respectively.

The liquid moisture management properties: Wetting time, Absorption Rate, Maximum Wetted Radius, Spreading Speed, Accumulative One-way Transport Capability, and Overall (liquid) Moisture Management Capability were determined according to AATCC TM 195-2017 *Liquid Moisture Management Properties of Textile Fabrics* on Moisture Management Tester (MMT M290 by SDL Atlas).

3. Results and Discussion

In this paper, the influence of lipase surface modification to polyester crystallinity and absorptivity was researched. For that purpose, the lipase surface modification of PET fabric was performed and compared to alkali hydrolysis.

The spectrum of each sample measured on FTIR-ATR, Spectrum 100, PerkinElmer between 1100 cm⁻¹ and 850 cm⁻¹ with characteristic peak are given in Figure 2. In this case, the crystalline regions contain only the trans-conformation of ethylene glycol, while the amorphous regions of the PES, in addition to the trans-, also contain the cis-conformation of ethylene glycol [11]. The difference in bands of used PET fabric to theoretical one for of PET film [12] depends on fibre/fabric processing. Therefore, absorption band closest to 973 cm⁻¹ was taken to calculate the degree of crystallinity. Furthermore, the IR absorption bands of PES at 1018 cm⁻¹ do not show sensitivity to changes in temperature, and can therefore be selected as absorption band for calculating the degree of crystallinity [13]. Values closest to 1018 cm⁻¹ were taken for the purposes of this paper. The degree of crystallinity was calculated according to (1) from the absorption peaks at 970 cm⁻¹ and 1017 cm⁻¹. the corrected absorption at the characteristic wavelengths and calculated degree of crystallinity of PET fabrics are shown in Table 2.

Table 2: The corrected absorption at the characteristic wavelengths and degree of crystallinity of PET fabrics

Sample	The corrected absorption at		Degree of crystallinity C [%]
	1017 cm ⁻¹	970 cm ⁻¹	
PET	0.39	0.12	29.65
PET-H	0.42	0.10	24.90
PET-L	0.40	0.10	24.73

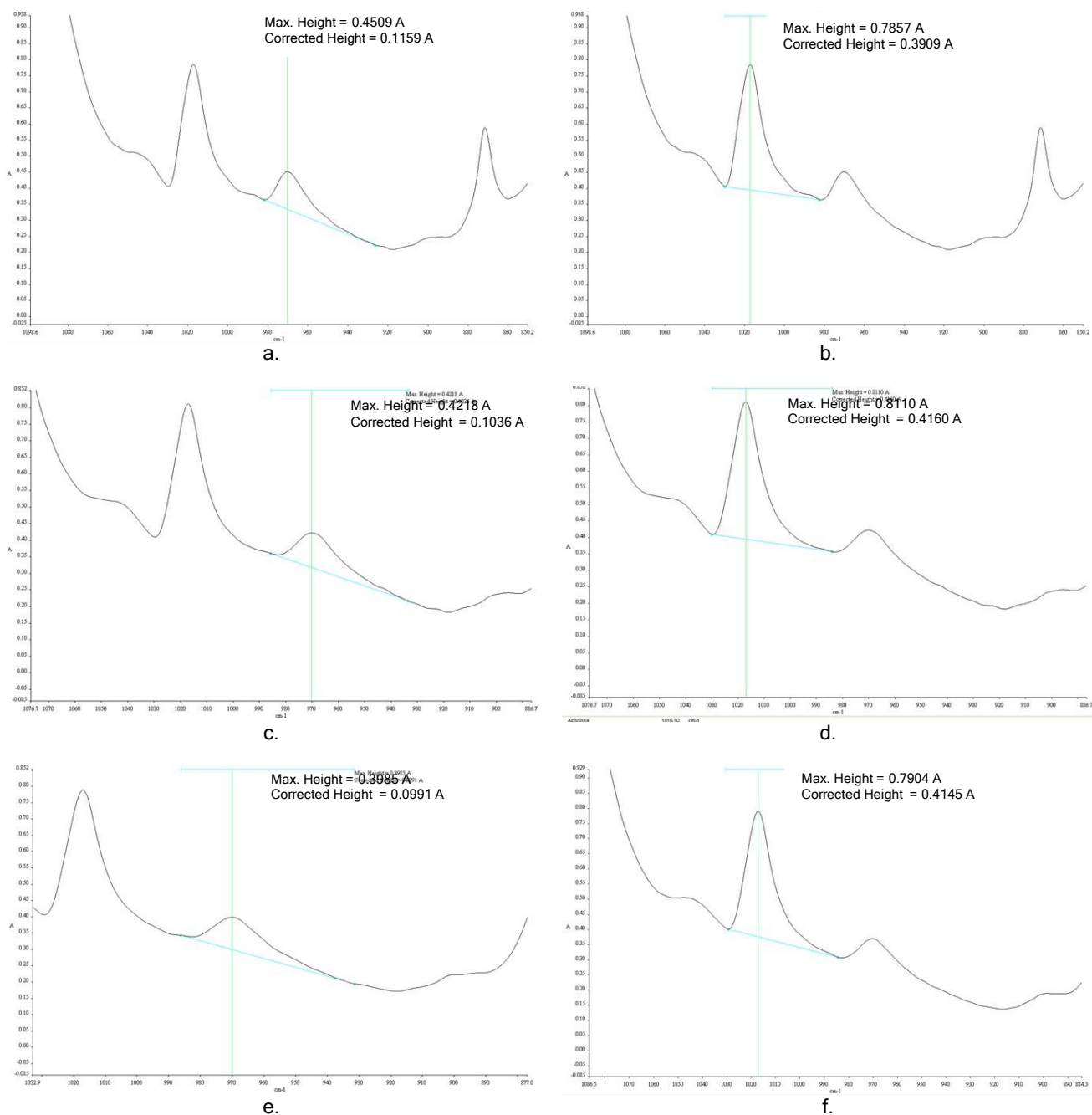

Figure 2: The characteristic FT-IR absorption band at wavelengths 970 cm⁻¹ (a, c, e) and 1017 cm⁻¹ (b, d, f) of untreated PET (a, b), alkali hydrolysed PES-H (c, d) and lipase hydrolysed PES-L (e, f) fabrics

According to the obtained values, the highest degree of crystallinity was obtained from the untreated PET (29.65%). The degree of crystallinity of alkali hydrolysed (24.90%) shows that the treatment resulted in lower crystallinity, hence the amorphous increased for 5%. Comparing the degree of crystallinity of lipase hydrolysed PET to alkali one, the achieved results is similar (24.73%), indicating similar modification.

It should be noted that FT-IR does not measure the total degree of crystallinity that varies with temperature, but only the degree of crystallinity relative to an amorphous fraction located at a wavelength of 1017 cm⁻¹, which is constant regardless of temperature, and which penetrates up to a maximum of 500 nm inside the fibre [11-13]. It is evident from the results that the crystallinity content of both hydrolysed PET samples decreased relative to the untreated sample.

The liquid moisture management properties were determined according to AATCC TM 195-2017 on Moisture Management Tester (MMT). Results are presented in Table 3 and as Grading Summary Table e.g. Finger Print in Figure 3.

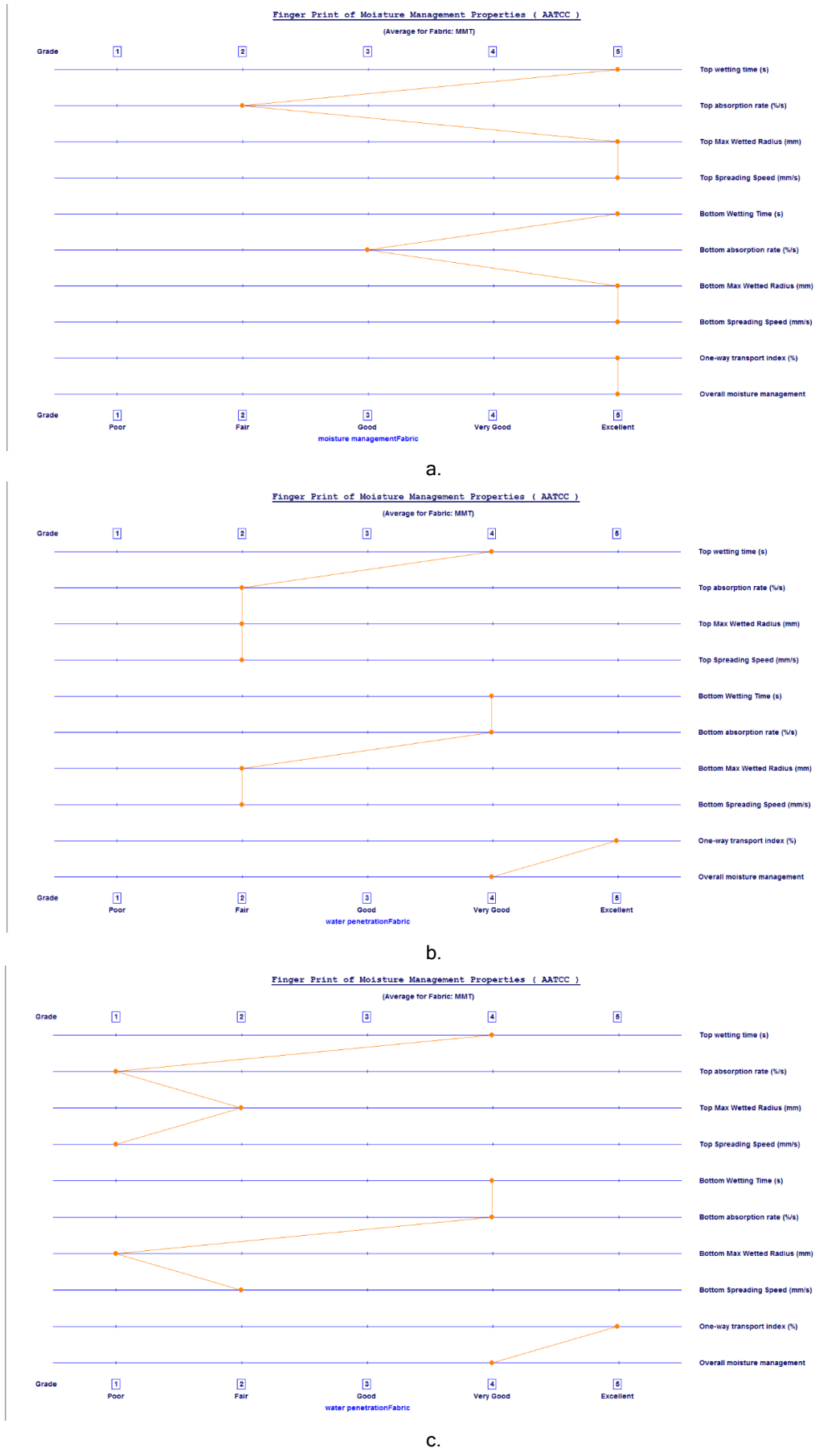

Figure 3: Fingerprint of PET fabrics according to AATCC TM 195-2017; a. PET, b. PET-H, and c. PET-L

Table 3: Moisture management properties of PET fabrics

	Wetting Time Top (s)	Wetting Time Bottom (s)	Top Absorption Rate (%/s)	Bottom Absorption Rate (%/s)	Top Max Wetted Radius (mm)	Bottom Max Wetted Radius (mm)	Top Spreading Speed (mm/s)	Bottom Spreading Speed (mm/s)	Accumulative One-way transport index (%)	OMMC
PET	0.187	0.187	16.7555	32.7435	23.3333	26.6667	20.698	20.8239	430.3915	0.8132
cv	0	0	0.0592	0.1472	0.1237	0.1083	0.0078	0.0138	0.0685	0.0165
PET-H	8.237	7.02	8.569	65.825	16.6667	16.6667	8.6749	8.6877	509.4471	0.6826
cv	0.9781	0.9084	0.5654	0.3768	0.6928	0.6928	1.5049	1.5091	0.3459	0.0725
PET-L	5.3353	3.4003	10.1718	52.6026	8.3333	6.6667	1.2694	1.5182	654.5040	0.6615
cv	0.4949	0.0693	0.3934	0.0105	0.3464	0.433	0.5014	0.2085	0.0567	0.0420

*cv - variation coefficient

The wetting time measured on MMT is the time period in which the top and bottom surfaces of the fabric just start to get wetted [14]. From Table 3 it can be seen that untreated fabric has extremely short WT, and large wetted radius indicating hydrophobic surface of high capillarity. It would be expected that hydrophobic PET have no wetting time. However, it is to point out here main difference between PET film and PET fabric: in the case of film surface is homogenous, whilst fabric has heterogeneous surface due to intra- and inter-yarn porosity [15]. In the case of hydrolysed PET, wetting time is 8 s for alkali and 5 s for lipase hydrolysed one. The reason is change of surface, and better absorbency, so the small amount of water is bonded to new PET surface groups. Therefore, bottom absorption rate is PET is significantly higher for hydrolysed PET fabrics. Absorption rate represents the average speed of liquid moisture absorption for the top and bottom surfaces of the specimen during the initial change of water content during a test. The spreading speed, which represents the accumulated rate of surface wetting from the centre of the sample where the test solution is dropped to the maximum wetted radius, on hydrophobic surface of untreated PET (20.7 mm/s) is faster than on hydrolysed PET (alkali 8.7 mm/s and lipase 1.3 mm/s) suggesting higher capillarity of untreated PET, but at the same time better absorption of hydrolysed ones.

Accumulative one-way transport capability (OWTC) represents the difference between the area of the liquid moisture content curves of the top and bottom surfaces of a specimen with respect to time. If the water content on top surface is much higher than on bottom one, the absorbency is higher. Therefore, hydrolysed PET higher OWTC and better absorbency than untreated one.

Overall (liquid) moisture management capability (OMMC) is calculated by combining three measured attributes of performance: the liquid moisture absorption rate on the bottom surface, the one-way liquid transport capability, and the maximum liquid moisture spreading speed on the bottom surface. It represents an index of the overall capability of a fabric to transport liquid moisture. Based on the results the MMT classifies fabrics [14]. For untreated PET fabric OMMC is excellent, suggesting moisture management fabric, whilst for hydrolysed ones is very good, suggesting water penetration fabric.

4. Conclusion

The influence of lipase surface modification to polyester crystallinity and absorptivity was researched. For that purpose, the lipase surface modification of PET fabric was performed and compared to alkali hydrolysis. It has been showed that lipase treatment lowers the PET crystallinity from 29.65 to 24.73%, similar as alkali hydrolysis 24.90%. The MMT results showed better absorption, indicating better comfort of such treated fabrics.

Acknowledgment:



This work has been supported in part by Croatian Science Foundation under the project UIP-2017-05-8780 HPROTEX.

This work is a result of Croatia-Serbia cooperation in science and technology 2019-2021 entitled "Bio-innovative polyesters".

References

- [1] Pfeifer H.: *Über den Abbau von Polyester fasern durch Hydrolyse und Aminolyse*, Westdeutscher Verlag, Köln, Germany (1964)
- [2] Kallay N.; Grancarić, A. M. & Tomić, M.: Kinetics of Polyester Fibre Dissolution, *Text. Res. J.* **60** (1990) 11, pp. 663-668, ISSN 0040-5175
- [3] Avny, Y., Rebenfeld, L.: Chemical modification of polyester fiber surfaces by amination reactions with multifunctional amines, *Journal of Applied Polymer Science* **32** (1986) 3, pp. 4009-4025, ISSN 0021-8995
- [4] Đorđević, D. *et al.*: Commercial and Laboratory Application of Enzymatic Lipase Preparation in the Polyester Fabric Processing to Improve the Sorption and Dyability Properties, *Tekstil* **55** (2006) 8, pp. 402-409, ISSN 0492-5882
- [5] Guebitz G. M. & Cavaco-Paulo, A. Enzymes go big: surface hydrolysis and functionalization of synthetic polymers. *Trends Biotechnol.* **26** (2008) 1, pp. 32-38, ISSN 0167-7799.
- [6] Tarbuk, A. *et al.*: Eco Surface Modifications of PET Fabric, *Book of Proceedings of the 7th International Textile, Clothing & Design Conference*, Dragčević, Z.; Hursa Šajatović, A.; Vujasinović, E. (Eds.). pp. 250-255, ISSN 1847-7275, Dubrovnik, Oct 2014, University of Zagreb Faculty of Textile Technology, Zagreb (2014)
- [7] Vertommen, M. A. M. E. *et al.*: Enzymatic surface modification of poly(ethylene terephthalate), *Journal of Biotechnology* **120** (2005) 4, pp. 376-386, ISSN 0168-1656
- [8] Donelli, I. *et al.*: Surface structure and properties of poly-(ethylene terephthalate) hydrolyzed by alkali and cutinase, *Polymer Degradation and Stability*, **95** (2010) 9, pp.1542-1550, ISSN 0141-3910
- [9] Tarbuk, A.; Grancarić, A. M. & Čorak, I.: Cutinase Hydrolysis of Poly(ethylene-terephthalate) Fabric, *Book of Proceedings of the 8th Central European Conference on Fiber-grade Polymers, Chemical Fibers and Special Textiles*, Dekanić, T.; Tarbuk, A. (Eds.), pp. 97-102, ISBN 978-953-7105-63-1, Zagreb, Sept 2015, University of Zagreb Faculty of Textile Technology, Zagreb (2015)
- [10] Farrow, G. & Bagley, J.: The Measurement of Molecular Orientation in Polyethylene Terephthalate Filaments by X-Ray Diffraction. *Text Res J.* **32** (1962) 7, pp. 587-598, ISSN 0040-5175
- [11] Yazdaniyan, M.; Ward, I. M. & Brody, H.: An infra-red study of the structure of oriented poly(ethylene terephthalate) fibres. *Polymer* **26** (1985) 12, pp. 1779-1790, ISSN 0032-3861
- [12] Miyake, A.: The infrared spectrum of polyethylene terephthalate. I The effect of crystallization, *Journal of polymer science*, **38** (1959) 134, pp. 479-495, ISSN 0887624X
- [13] Ward, I. M. & Wilding, M. A.: Infra-red and Raman spectra of poly(m-methylene terephthalate) polymers, *Polymer* **18** (1977) 4, pp. 327-335. ISSN 0032-3861
- [14] M290 Moisture Management Tester, Instruction Manual, Rev. 1.4 (06/18) www.sdlatlas.com
- [15] Grancarić, A. M.; Chibowski, E. & Tarbuk, A.: Surface Free Energy of Textiles (Slobodna površinska energija tekstila), *Tekstil* **57** (2008) 1-2; pp. 29-39, ISSN 0492-5882

Authors:

Assoc. Prof. Anita TARBUK, PhD; Assoc. Prof. Sandra FLINČEC GRGAC, PhD; Eva MAGOVAC, mag. ing.; Ivana ČORAK, mag. ing.
University of Zagreb Faculty of Textile Technology, Department of Textile Chemistry and Ecology
Prilaz baruna Filipovića 28a, HR-10000 Zagreb, Croatia
Phone: +385 1 3712 500

E-mail: anita.tarbuk@tff.unizg.hr
E-mail: sflincec@tff.unizg.hr
E-mail: eva.magovac@tff.unizg.hr
E-mail: ivana.corak@tff.unizg.hr

Prof. Dragan ĐORĐEVIĆ, Ph.D.; Marija KODRIĆ, M. Tech.
University of Nis, Faculty of Technology, Textile Department
Bulevar Oslobođenja 124, 16000 Leskovac, Serbia
Phone: +381 16 247 203

E-mail: drdrag64@yahoo.com
E-mail: izida50@gmail.com

BIOPROCESSING OF POLYESTER KNITWEAR BY PAPAIN ENZYMES

Dragan ĐORĐEVIĆ; Anita TARBUK; Marija, KODRIĆ; Radica NIČIĆ; Nenad ĆIRKOVIĆ & Nemanja VUČKOVIĆ

Abstract: *The possibilities of the application of commercial papain enzymes from the papaya latex and its application in the modification of polyester knitwear were investigated in this paper. Two types of papain enzymes of corresponding properties were used together with activators to modify the surface morphology of polyester fibres. The polyester knitwear was treated with different temperature, pH, treatment time, and concentration. The optimal papain treatment conditions were identified as a pH 8, at temperature 40°C, for 120 min, and papain concentration of 75 %. The results show that the papain treatments bring adequate effects. Especially, it was to refer to a water penetration, absorption and wetting time. The mechanical indicators are also checked (strength, elongation). Scanning electron microscopy has utilized to the structural and morphological understanding of polyester fibres surface in treated regime. This study confirmed that papain acts as an esterase, hydrolysing ester bonds in polyester fibres in knitwear.*

Keywords: *polyester knitwear, papain enzyme, papaya latex, mechanical properties, sorption properties.*

1. Introduction

Poly(ethylene terephthalate) (PET) fibre is the commonly used fibre for majority of end-use applications. Today, the polyester fibre market accounts for about half of the total global fibre market. Synthetic polyesters have gained a significant share from most other man-made and natural fibres because of their superior properties like high strength and toughness, waterproofing, high volume to weight ratio, and stain resistance. These characteristics made them an essential material in almost every manufacturing industry with major application in the production of fabrics for clothing, garments, or other finished textile goods. PET has been considered resistant to biodegradation, and the resulting large-scale accumulation of plastic waste in the biosphere has given rise to the problem of severe environmental pollution [1].

Green chemistry using biotechnology has joined incredible importance in the textile wet processing industry. The search for new, efficient and eco-friendly alternatives have increased interest in using green catalysts i.e. enzymes. Developments in genetic engineering bring about improvements in the stability, specificity, economy as well as overall application potential of industrial enzymes in textile finishing. Over the past four to five decades not only is the demand for poly(ethylene terephthalate) textile fibres increasing, but also the desire for improved textile properties such as wettability or hydrophilicity. Furthermore, effects like better dyeability with water soluble dyes or surface functionalization for special purposes like coupling of flame retardants are desirable from the perspective of the textile industry [2,3].

Recent studies have reported a new way for surface modification of synthetic polymers: enzymatic treatment. Enzymes are catalysts for reactions with high selectivity and specificity in mild conditions. From an economic and ecological point of view, new processes using lipase, proteases, papain, glycosidases etc. are safe with low energy consumption. It may lead to huge developments and wide applications of enzymes in the functionalization of polymer surface [2,4]. Furthermore, researchers are interested in the benefits in material performance brought by new enzyme treatment compared to chemical hydrolysing technologies. The mechanism of the hydrolysis was deeply explored by studying the kinetics of hydrolysis process and the surface properties of polyester. As an efficient and economic process for potential industry applications, the new enzyme treatment technology for PET fiber was systematically studied together with traditional alkali treatment technology [5,6].

Papain, also known as papaya proteinase I, is a cysteine protease (EC 3.4.22.2) enzyme that is found in species of papaya, *Carica papaya* and *Vasconcellea cundinamarcensis*. The enzyme is found to be localized in the skin of papaya, and is collected from slashed unripe papayas as a crude latex. Papain is used in food, pharmaceutical, textile, and cosmetic industries. While it has been used for the treatment of inflammation and pain via topical administration, papain has also shown to have anthelmintic and tooth-whitening properties. Present in over-the-counter mixture products consisting of different digestive enzymes, its active site contains a catalytic diad that plays a role in breaking peptide bonds. Papain is also used as an ingredient in various enzymatic debriding preparations [7,8].

In this paper, the efficacy check of papain enzymes against polyester as a substrate, was made in order to achieve adequate effects that can improve the usable properties of textile products.

2. Material and Methods

In the experimental part of this research, raw, undyed 100 % polyester (polyethylene terephthalate) knitted fabric has been used which is common in practice with the following characteristics: interlacement interlock, fineness of yarn 10 tex, course count 14 cm⁻¹, wale count 15 cm⁻¹ and surface mass 145 g/m².

Prior to treatment with papaya enzymes, PET knitwear was washed in pure distilled water (liquor-to-textile ratio 100:1, 40°C, 30 min). Subsequently, the knitwear was dried at room temperature. The enzyme used was commercial papain (Sigma-Aldrich, USA), the properties of the papains are presented in Table 1.

The buffer solution (pH 8) used was a mixture of tris (hydroxymethyl) aminomethane (Centrohem, Serbia) and HCl (Centrohem, Serbia), (100 ml 0.1 M tris (hydroxymethyl) aminomethane + 58.4 ml 0.1 M HCl).

Ethylenediaminetetraacetic acid (EDTA, Centrohem, Serbia) was used as activator in concentration 5% owf. The samples of polyester knitwear were treated with papain in Tris buffer solution, using a liquor ratio (LR) 1:60. The concentrations of both papain enzymes, for processing polyesters was 75% (owb). It should be noted that concentrations of papain (%), both enzymes, for processing polyesters ranged from 5% to 80% (o.w.b.). A concentration of 75% proved to be most effective in the effects achieved on PET fibres.

All the enzyme treatments were carried out in LINITEST laboratory machine with LR 1:60, at pH 8, 40°C for 120 min. Subsequently, the inactivation of the enzyme was performed in such a way that the PET samples were immersed in hot water (90°C) with the LR 1:40 for 15 minutes. Table 2 shows data related to the labels and content of polyester processing recipes.

Table 1: Labels, origins and characteristics of enzymes

Labels	Enzyme origins	Characteristics
P1	papaya latex, Carica Papaya	crude powder, 1.5-10 units/mg, mol. wt. 21 kDa
P2	papaya latex, Carica Papaya	lyophilized powder, ≥10 units/mg, mol. wt. 21 kDa

Table 2: Labels and recipes processing of polyester knitwear

Labels	Treatments
PET	Untreated PET knitwear
PET-P1	PET knitwear treated with P1 enzyme
PET-P2	PET knitwear treated with P2 enzyme

The characterization of surface and chemical composition of such modified polyester knitwear was performed applying instrumental methods - scanning electron microscopy (SEM), JEOL JSM-6610LV (Jeol, Japan). Fourier-transform infrared spectroscopy (FTIR) spectra of PET samples registered on the device FTIR spectrophotometer Bomem Hartmann & Braun MB-series in the range of wavelengths of 4000-400 cm⁻¹. The mechanical properties of knitting fabric are determined on the basis of the ASTM D2594-04 standard. For checking the effects of enzyme hydrolysis, the following methods have been used: the power of water absorption-capillarity, SRPS F.S2.042; the power of water absorption, SRPS F.S2.041 and time of wetting, AATCC TM27-2013. The hydrophilicity methods of PES samples were checked on 5 samples each and the results of the mean values of these measurements are presented.

3. Results and Discussion

It is noticeable that a large amount of papain enzyme was applied. This is due to the effects on the polyester, which were absent from smaller amounts of the enzyme. Understandable as it is an enzyme that is primarily a protease that hydrolyses both amides and esters [9]. The surface characterization of modified polyester knit fabric was performed by FTIR and SEM. Figure 1 gives comparative FTIR spectra of modified (PET-P1) and unmodified-control polyester (PET) sample based on which the appearance of structural transformations can be determined by changing the intensity of a functional group, the emergence of a new or loss of an existing group, and etc. From this figure, i.e. spectral lines, it can be noticed that practically there are no major changes; the position and size of the strip are largely identical with minimal variation. The spectrum for PET-P2 is not shown in this figure because it is very similar to the spectrum for papain P1, practically the curves coincide.

These absorption peaks were attributed as follows. Asymmetry stretching aliphatic vibration of C-H of the methylene, symmetry stretching aliphatic vibration of C-H of the methylene, bending (scissoring) vibration of C-H of the methylene, in plane C-H deformation of the aromatic ring, ester (C-O) stretching-trans, and CH₂ out-of-plane bending vibrations are indicative by the peaks at 2967, 2852, 1456, 1410, 1292, 873, and 725 cm⁻¹, respectively. The band at 1341 cm⁻¹ that corresponds to CH₂ wagging of trans conformation of the ethylene glycol unit [10].

The bands at 3432 and 1016 cm⁻¹ are characterized by intermolecular O-H bonded to C=O groups and O-H out-of-plane bending in terminal carboxylic domains of polymer. The bands at 1504 and 1094 cm⁻¹ are assigned to C-C and C-O-O stretching vibrations. A strong band observed at 1712 cm⁻¹ is related to C=O symmetric stretching of carbonyl groups [10].

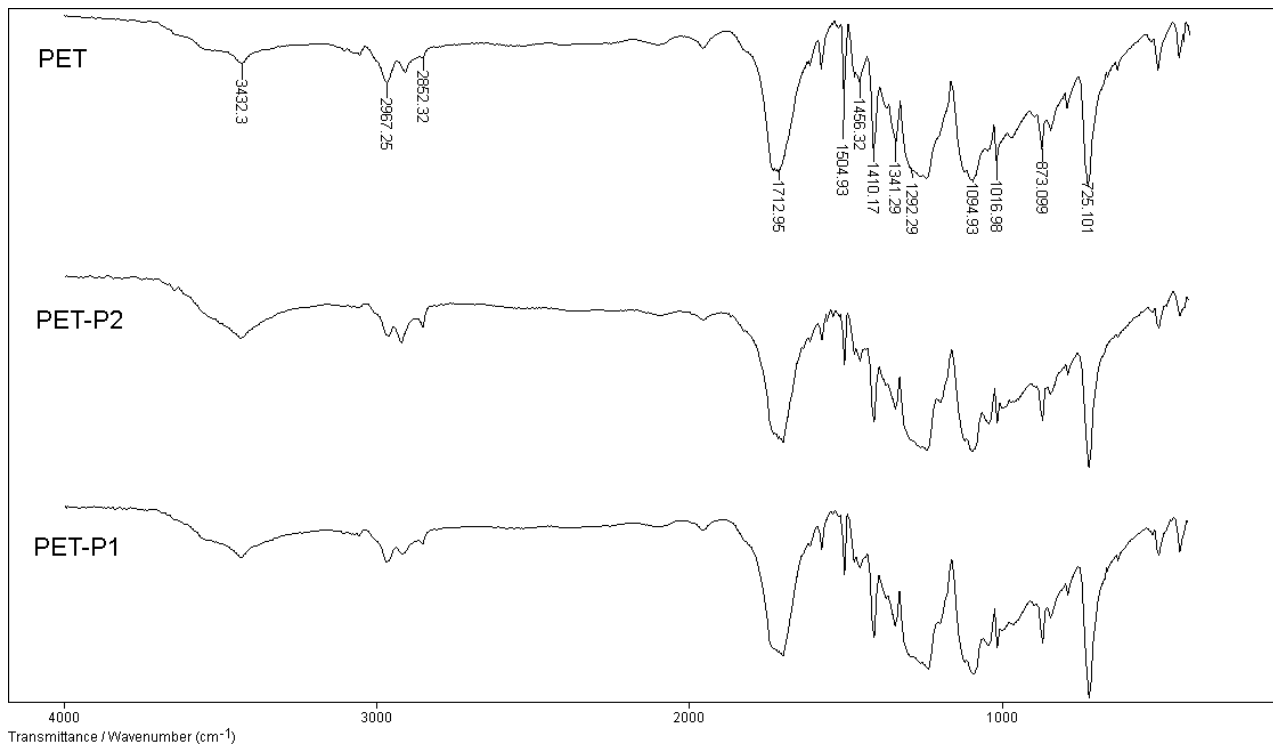

Figure 1: FTIR diagram of PET and PET-treated samples

From SEM micrographs of polyester knitwear before (PET) and after treatment with papain enzymes (PET-P1, PET-P2), shown in Figure 2, it can be seen that untreated PET has relative smooth microscopic appearances, Fig. 2A. In most cases, the primary enzyme's attack catalysed hydrolysis of ester in the PET fibres. This first step of the process is a surface erosion process (enzymes cannot penetrate the polymer bulk). Because of the sheer size of the enzyme molecules, hydrolysis on polyester fibres is limited to the surface. Hydrolytic chain scissions can occur along the polyester chain and possibly the end unit. The changes on of papain-treated PET fibre surface are visible on SEM micrographs (Figure 2B and 2C)

The surface indicated appearance of peelings, differentiation and stratification of the surface layers of the fibres. It is assumed that the active agents caused visible changes of the surface of the polyester fibre, which, ultimately, can derive from the enzymes. These changes in the surface layers of the fibers due to the action of the enzyme define the surface morphology, which directly affects the ability to absorb moisture, which is the main objective of this research.

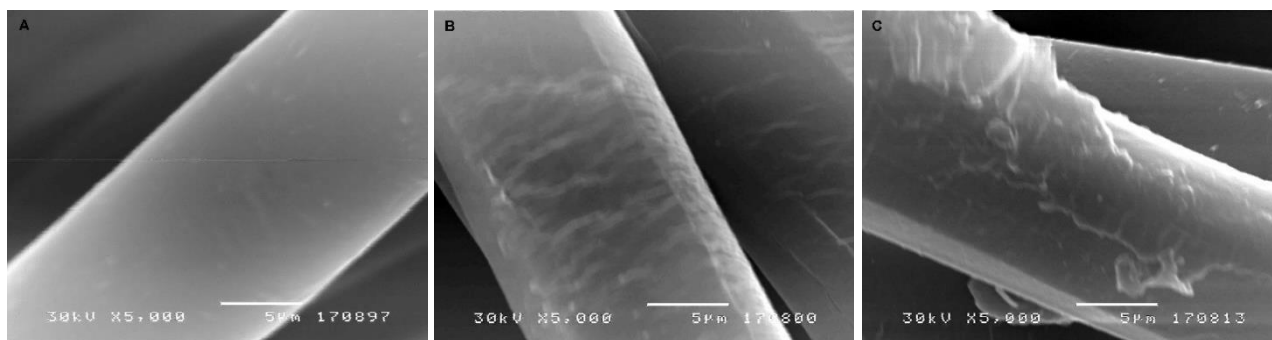

Figure 2: SEM micrographs of polyester knitwear at magnification of 5000 \times : A - untreated PET; B - PET-P1; C - PET-P2; The results of breaking strength tests of the treated PET knitted fabric samples have been slightly worse comparing with the control samples, Fig. 3. Moreover, relatively long time of treatment and the presence of papain enzymes have probably resulted structure reorganisation of the surface layers when arose worse results. The breaking strength and elongation of break from the enzymes treated PET knitwear (Fig. 3) are 218 N (PET-P2, wale direction) in worst case and 220 N (PET-P1, wale direction). Results in course direction of PET knitwear was similar and not showed in the diagram of the figure 3. In general, changes in surface fibres have determinate of behaviour of PET yarns and knitwear during the investigation. The elongation of break slightly changed showing slightly higher values in %.

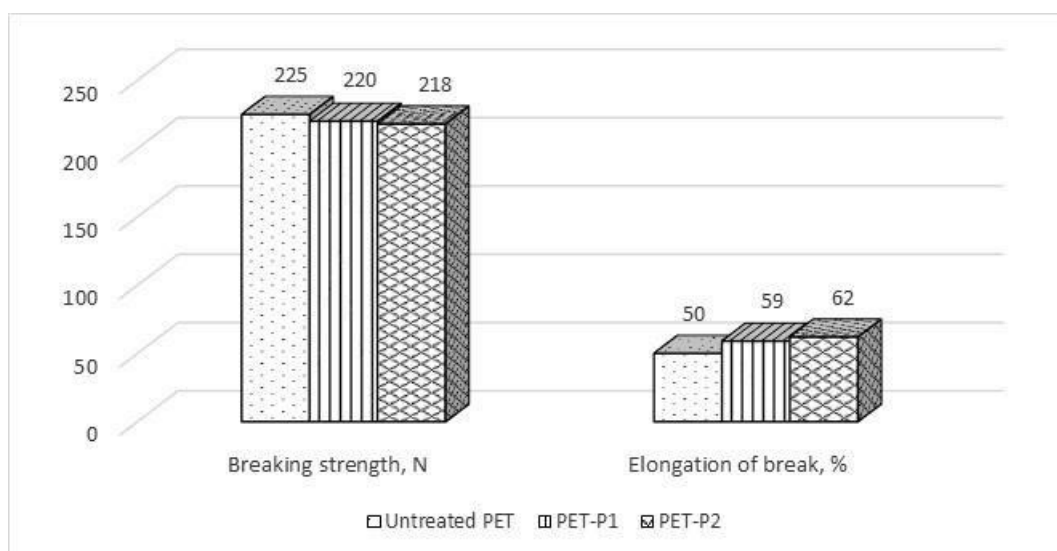

Figure 3: Breaking strength and elongation of break of PET knitwear in enzyme modification mode (wale direction)

Wettability of PET fibres certainly depend of changes in surface layers of fibres during enzymatic processing. The wettability of the surface is directly connected to the surface energy, so the energy stable surface has lower ability of wetting. Materials with lower wettability (less hydrophilic, i.e. hydrophobic), such as polyester, have weaker ability of dyeing and lower resistance to soiling. The treatment of alkali can be a good and recognizably efficient means for improving the surface wettability of hydrophobic polymer surfaces. This improved wettability is ascribed to increasing amount of polar groups, surface deformation, increased roughness of the surface of the material etc. [9]. The results of water absorption, capillarity and wetting time are shown in Table 3.

The water absorption from the PET knit fabric confirms that the treated samples go in the direction of increasing this tested parameter, i.e. have better results. The best results were shown by the use of P1 papain enzyme, which has a value of 263% (22.3% better result than the untreated sample), while the papain enzyme P2 has a value of 259% (20.5% better result than the untreated sample).

Capillarity of PET fibres certainly depend of changes in surface layers of fibers during enzymatic processing. Water penetration along horizontal and vertical column is pretty much equal, regarding that the density is almost equal in all directions so the influence of density and capillaries is excluded, practically. It should be pointed out that the unprocessed sample of knitted fabric almost does not show water penetration through its

structure, i.e. the capillarity in both directions not exceeding 1 mm, whereas in the processed samples, it is from 20/17 to 22/20 mm (Wale/Course), Table 3.

According to results of Table 3, it can be noticed that the enzyme modified samples of knitted fabric wet faster. The unprocessed sample of PET knitted fabric has the slowest wetting, 305 s; the best results, i.e. the most hydrophilic surface of knitwear and then the fastest wetting is obtained by the hydrolysis in the presence of papain P1, 15 s.

The hydrophilicity, e.g. adsorption ability, depends on the number of the available groups as well. Surface modification of polyester knitwear increased the number of active groups on the knitwear surface resulting in better wetting.

Table 3: Water absorption, capillarity and wetting of PET knitted fabric after papain hydrolysis

Sample	Water absorption (%)	Capillarity (mm)		Wetting time (s)
		Wale	Course	
Untreated PET	215	1	0.5	305
PET-P1	263	20	17	15
PET-P2	259	22	20	19

4. Conclusions

Due to the extreme crystallinity polyester fibres, PET textile absorbs small amounts of water, as well as other textile auxiliaries, such are optical brighteners, dyestuff etc. Modifications of poly(ethylene-terephthalate) textile by papain enzymes change the knitwear surface properties. The change in chemical composition did not occur but it led to PET knitwear functionalization. Surface changes on the surface during enzyme papain hydrolysis of PET fibres results in increased hydrophilicity and a more open and accessible structure, which leads to slightly reduced knitwear strength.

In fact, both papain enzymes have performed well on polyester knitwear. The differences in results are minimal, so they cannot be separated, both are good enough because they achieve even results. The economic aspect of the application of enzymes in the PET knitted fabric processing is reflected in the effects achieved. However, it must be considered that the price of commercial papain used for sophisticated products can be much. To that effect, it may be interesting to consider the use of laboratory-produced papain. So, the continuation of this article could be an attempt to examine the possibility of papaya enzyme production in the traditional way in the laboratory and its use in textile processing.

References

- [1] Coruh E.: Optimization of Comfort Properties of Single Jersey Knitted Fabrics, *Fibres & Textiles in Eastern Europe*, **23** (2015) 4, pp. 66-72, ISSN 1230-3666.
- [2] Robic A. et al: Enzymes for industrial applications, *Oilseeds and Fats, Crops and Lipids*, **24** (2017) 4, pp. 2-6, ISSN 2272-6977.
- [3] Quartinello F. et al: Synergistic chemo-enzymatic hydrolysis of poly (ethylene terephthalate) from textile waste, *Microbial Biotechnology*, **10** (2017) 6, pp. 1376-1383, ISSN 1751-7907.
- [4] Nakajima-Kambe T. et al: Microbial degradation of polyurethane, polyester polyurethanes and polyether polyurethanes, *Applied Microbiology and Biotechnology*, **51** (1999) pp. 134-140, ISSN 0175-7598.
- [5] Teeraphatpornchai T. et al: Isolation and characterization of a bacterium that degrades various polyester-based biodegradable plastics, *Biotechnology Letters*, **25** (2003) pp. 23-28, ISSN 0141-5492.
- [6] Wei R. et al: Functional characterization and structural modeling of synthetic polyester-degrading hydrolases from *Thermomonospora curvata*, *AMB Express*, **44** (2014) 4, pp. 1-10, ISSN 2191-0855
- [7] Welde Y.; Worku A.; Identification and extraction of papain enzyme from papaya leaf in adigrat town, northern Ethiopia, *Journal of Medicinal Plants Studies*, **6** (2018) 3, pp. 127-130, ISSN 1996-0875.
- [8] Kim I.Y.: Effects of Sodium Sulfate and Surfactants on Papain Treatment of Wool Fabrics, *Fashion & Textile Research Journal*, **16** (2014) 2, pp. 333-338, ISSN 1229-2060.
- [9] Dupret I. et al: Biodegradation of polyester-amides using a pure strain of micro-organisms or papain I. *Model compounds*, **67** (2000) 3, pp. 497-504, ISSN 0141-3910.
- [10] Gunasekaran S.; Hemamalini R.: Spectroscopic analysis of the structure of repeat unit of polyethylene terephthalate (PET), *Indian Journal of Pure & Applied Physics*, **42** (2004) 4, pp. 246-250, ISSN 0019-5596.

Authors:

Prof. Dragan ĐORĐEVIĆ, Ph.D. (corresponding author)
University of Nis, Faculty of Technology, Textile Department
Bulevar Oslobođenja 124, 16000 Leskovac, Serbia
Phone: +(381) (16) 247 203 Phone: +(381) (16) 247 203 E-mail: drdrag64@yahoo.com

Assoc. Prof. Anita TARBUK, Ph.D.
University of Zagreb, Faculty of Textile Technology, Department of Textile Chemistry and Ecology
Prilaz baruna Filipovića 28a, 10000 Zagreb, Croatia
Phone: +(385) (1) 37 12 575 Fax: +(385) (1) 37 12 500 E-mail: anita.tarbuk@ttf.hr

Marija KODRIĆ, M. Tech., Ph.D. student
University of Nis, Faculty of Technology, Textile Department
Bulevar Oslobođenja 124, 16000 Leskovac, Serbia
Phone: +(381) (16) 247 203 Phone: +(381) (16) 247 203 E-mail: izida50@gmail.com

Radica NIČIĆ, M. Tech., Ph.D. student
University of Nis, Faculty of Technology, Textile Department
Bulevar Oslobođenja 124, 16000 Leskovac, Serbia
Phone: +(381) (16) 247 203 Phone: +(381) (16) 247 203 E-mail: radicanic@rocketmail.com

Assist. Prof. Nenad ĆIRKOVIĆ, Ph.D.
University of Nis, Faculty of Technology, Textile Department
Bulevar Oslobođenja 124, 16000 Leskovac, Serbia
Phone: +(381) (16) 247 203 Phone: +(381) (16) 247 203 E-mail: nenadcira@gmail.com

Nemanja VUČKOVIĆ, M. Tech. Ph.D. student
University of Nis, Faculty of Technology, Textile Department
Bulevar Oslobođenja 124, 16000 Leskovac, Serbia
Phone: +(381) (16) 247 203 Phone: +(381) (16) 247 203 E-mail: vucko989@gmail.com

THE OPTIMIZATION OF DI(CYANSTYRYL) DERIVATIVE APPLICATION TO POLYESTER FABRIC AND ITS BLEND

Ivana ČORAK; Tihana DEKANIĆ; Petra KAŠAJ & Anita TARBUK

Abstract: UV protection can be achieved by polyester fabric due to benzene rings in the polymer molecule, but also has small absorption due to high fibre crystallinity. Blended with cotton, hydrophilicity and comfort improves, but UV protection is getting lower. It is well known that optical brightening with fluorescent whitening agents (FWA's) contributes to UV protection, as well as fabric whiteness. In this paper, the new FWA by DyStar, Sera® White P-N, a di(cyanstyryl) derivative, was applied in high concentration range (0.1, 0.5, 1, 5, 10, and 20% owf) on standard polyester and polyester blend with cotton fabrics by WFK for the purpose of optimization. Therefore, the fluorescence of FWA solutions was determined on fluorometer HITACHI F-7000 FL. After fabric treatment with FWA, whiteness (W_{CIE}) according to ISO 105-J02:1997, and tint value and deviation were calculated automatically from the measured remission on a remission spectrophotometer Spectraflash SF 600 PLUS-CT, tt. Datacolor. The UV protection ability was determined according to AS/NZS 4399:1996 using transmission spectrophotometer Cary 50/ Solascreen, Varian.

Keywords: polyester fabric, polyester/cotton blend, fluorescent whitening agent (FWA), whiteness, tint, UV protection

1. Introduction

Long exposure to solar ultraviolet radiation (UV-R), along with the amount of skin pigmentation, is the primary cause of skin cancer. The risk of subsequent occurrence of skin cancer increased all over the world due to the demolishing of ozone layer, but may be reduced by proper and early photoprotection. UV protection depends on many factors such as type of fibre, construction, fabric surface, density, moisture content, presence of nanoparticles, fluorescent whitening agents (FWA's) and UV absorbers if applied. It is well known that optical brightening with FWAs to UV protection, as well as to the fabric whiteness. UV protection can be achieved by fibre blending as well. The polyester fabric due to benzene rings in the polymer molecule shows UV protection, but has small absorption of auxiliaries due to high fibre crystallinity. Blended with cotton, hydrophilicity and comfort improves, but UV protection is getting lower. The optical brightened fabrics absorb UV-A radiation, transform it into blue fluorescence, lowering UV transmission which results in high ultraviolet protection factor (UPF), indicating better UV protection [1-10]. Therefore, in this paper, the application of the new FWA by DyStar, Sera® White P-N, to polyester and polyester blend with cotton fabrics was researched for the purpose of optimization fabric whiteness and UV protection.

2. Materials and Methods

Standard polyester fabric (PES) and polyester/cotton fabric (PES/CO) (65%/35%) by WFK, having mass per unit area 170 g/ m², plain weave, 295/295 dtex, were used in this research. Fabrics were treated with Sera® White P-N by DyStar, a FWA based on di(cyanstyryl) derivative in wide concentration range: 0.1, 0.5, 1, 5, 10, and 20% owf (over weight of fibre) by batch wise method having LR 1:30 at 90°C for 30 min in stainless-steel bowls (Polymat, Mathis). After processing, fabrics were air dried. Labels and treatments are listed in Tab. 1.

Table 1: Labels and treatment of PES and PES/CO fabrics

Label	Treatment
PES	Untreated PES fabric
PES/CO	Untreated PES/CO fabric
...-PN-...	Sera® White P-N
...conc	concentration of optical brightener-0.1, 0.5, 1, 5, 10, 20 % owf

Before the treatment the fluorescence of FWA solutions was determined on fluorometer HITACHI F-7000 FL.

Remission was measured on a remission spectrophotometer Spectraflash SF 300, Datacolor. Fabric whiteness (W_{CIE}) was calculated automatically according to ISO 105-J02:1997 *Textiles – Tests for colour fastness – Part J02: Instrumental assessment of relative whiteness*. Corresponding Tint Deviations (TD) and its coloristic meanings is determined as well according to Griesser [11].

The UV protection ability of modified PES and PES/CO fabrics treated with FWA was determined according to AS/NZS 4399:1996 *Sun protective clothing – Evaluation and classification* using transmission spectrophotometer Cary 50/ Solascreen, Varian.

3. Results and Discussion

In this paper the treatment of PES and PES/CO fabrics with new FWA by DyStar, Sera® White P-N, a di(cyanstyryl) derivative, was researched. For the optimization the FWA was applied in a wide concentration range. Firstly, the fluorescence of FWA solutions was determined on fluorometer HITACHI F-7000 FL. The results are presented in Fig. 1.

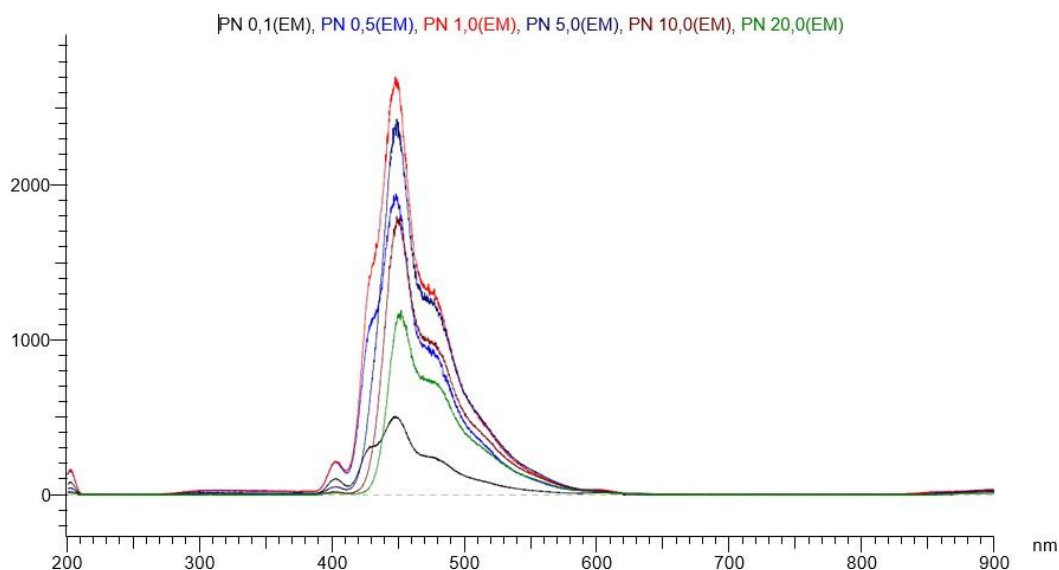
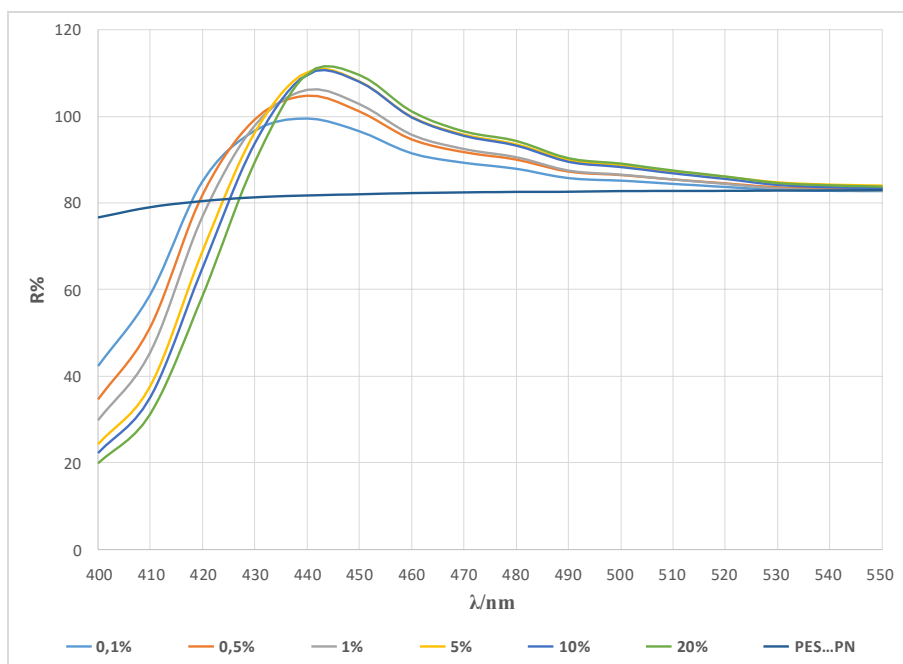

Figure 1. The fluorescence emission spectra of FWA solution of Sera® White P-N

From the Fig. 1. it can be seen that the emission of the optical brightener Sera® White P-N is at 445 nm. The greatest emission peak of fluorescence is for the concentration of 1%. At higher FWA concentration the lowering of fluorescence emission is occurring. After application to the PES and PES/CO fabrics, similar behaviour can be observed on remission curves (Fig.2).

From Fig. 2 and Tab. 2-3 can be seen that untreated PES and PES/CO fabrics have remission at 700 nm, and whiteness degree of 80, with no appreciable deviation in tint from the white scale. Treatment with the lowest concentration of optical brightener 0.1 % owf leads to the significantly higher whiteness (W_{CIE} 110 for PES and 106 for PES/CO) due to fluorescence emission at 440 nm. Treatment with small FWA concentration, 0.1 and 0.5 % owf have no appreciable deviation in tint from the white scale.

With the increment of concentration whiteness degree is getting higher till optimal concentration. For PES fabric the optimal concentration is 5 % whilst for PES/CO fabric is 1% owf (W_{CIE} for PES is 120.4 and for PES/CO 116.9). The remission maximum is at 445 nm, what correlates with the emission spectra of FWA solution (Fig.1). From Tab. 2 can be seen that these concentrations lead to the highest whiteness, however the mall tinting occur. Both fabrics are a trace greener than the white scale.



a.

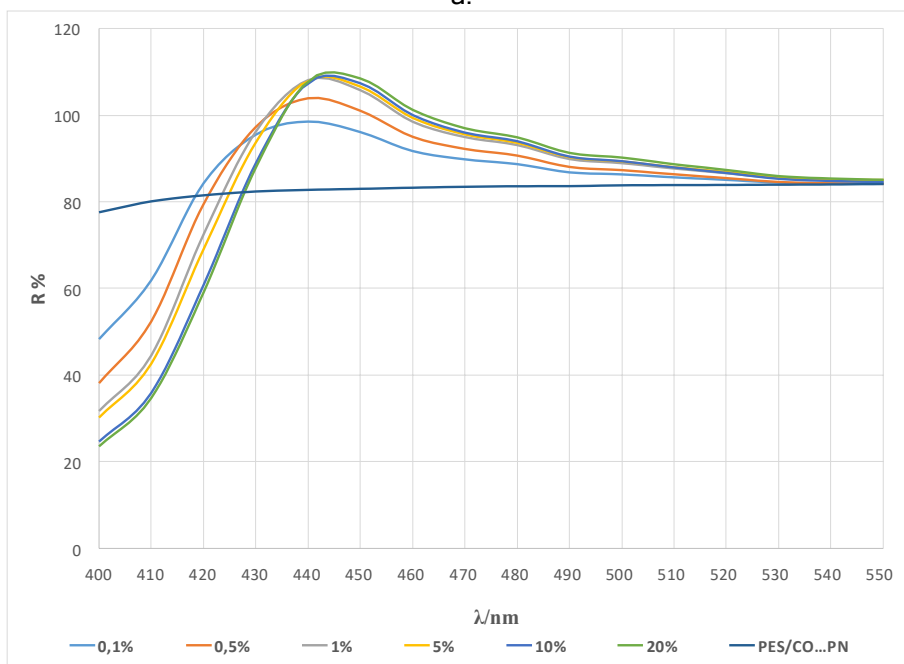

b.

Figure 2: Remission curves of Sera@ White P-N treated a. PES, and b. PES/CO fabric in a wide concentration range

Applied in the higher concentration than optimal one from results of remission and wavelength maximums, presented in Tab. 2 and Fig. 2, it can be seen that change in emission spectrum occurred. The increment of FWA led to a reduction of remission intensity causing the extinction of fluorescence by quenching phenomenon, with a consequence of tinting. The bathochromic shift of the remission spectrum confirms that since remission maximum has moved from 445 to 450 nm. As a result of quenching at the highest applied concentrations of 20% owf fabrics are slightly greener than the white scale.

Comparing the results on PES and on PES/CO fabrics it can be seen that slightly better results have been achieved on PES fabric. The reason for this is in affinity of di(cyanstyryl) derivative to polyester fibres. Since in PES/CO fabric is 35% of cotton fibres, whiteness is slightly lower.

Table 2: CIE whiteness (W_{CIE}) of PES and PES/CO fabrics after treatment with Sera® White P-N in a wide concentration range, maximum of remission (R_{max}) and wavelength (λ_{max}), and the corresponding Tint Values (TV) and Tint Deviations (TD) and its coloristic meaning

Fabric	W_{CIE}	R_{max}	λ_{max} [nm]	TV	TD	Coloristic meaning
PES	79.1	85.04	700	-0.1		No appreciable deviation in tint from the white scale
PES-PN-0.1%	110.2	99.59	440	-0.3		No appreciable deviation in tint from the white scale
PES-PN-0.5%	116.5	101.15	440	-0.1		No appreciable deviation in tint from the white scale
PES-PN-1%	117.6	106.11	440	0.4		No appreciable deviation in tint from the white scale
PES-PN-5%	120.4	110.22	445	1.2	G1	Trace greener than the white scale
PES-PN-10%	119.3	109.70	445	1.5	G2	Slightly greener than the white scale
PES-PN-20%	117.4	109.90	445	2.2	G2	Slightly greener than the white scale
PES/CO	80.0	83.78	700	-0.2		No appreciable deviation in tint from the white scale
PES/CO-PN-0.1%	106.6	98.57	440	-0.2		No appreciable deviation in tint from the white scale
PES/CO-PN-0.5%	113.5	103.95	440	0.2		No appreciable deviation in tint from the white scale
PES/CO-PN-1%	116.9	108.07	445	0.9	G1	Trace greener than the white scale
PES/CO-PN-5%	116.0	108.05	445	1.3	G1	Trace greener than the white scale
PES/CO-PN-10%	113.6	107.61	445	2.1	G2	Slightly greener than the white scale
PES/CO-PN-20%	113.4	108.56	450	2.3	G2	Slightly greener than the white scale

The impact of FWA concentration on the UV protection of PES and PES/CO fabrics was monitored by the UV-A and UV-B transmission and UPF (Tab. 3). Due to the benzene rings in the polymer molecule, PES fabric absorbs UV radiation leading to excellent UV protection (UPF=200.2). Removing cotton impurities in scouring and bleaching processes, leads to low UV protection. Therefore, if PES is blended with cotton (PES/CO), UV protection is getting lower (UPF=113.5).

From the results shown in Tab. 3 can be seen that fluorescent whitening agent applied even in small concentration leads to higher UPF ($UPF_{PES-0.1\%} = 773.4$, $UPF_{PES/CO-0.1\%} = 382.6$). Since the molecules of FWAs show the phenomenon of fluorescence based on electronically-excited state by UV-R energy (340-370 nm) it gives high whiteness of outstanding brightness by reemitting the energy at the blue region (typically 420-470 nm) of the spectrum [1,6,9]. Increment of FWA concentration leads to even higher UPF due to absorbing UV-A radiation. At optimal concentration for whiteness it can be seen that the maximum UPF of 1000 has been achieved. However, the fabrics with the highest intensity of fluorescence do not show the highest UPF values. UV protection increase with FWA concentration, regardless of quenching phenomenon.

Comparing the results of UV protection on PES and on PES/CO fabrics it can be seen that slightly better results again have been achieved on PES fabric. The reason for this can be affinity of di(cyanstyryl) derivative to polyester fibres, but also benzene rings in the polymer molecule. Since in PES/CO is blended with cotton, the UV protection is slightly lower, but still excellent. When treated with >1% maximum UPF was achieved.

Table 3. Ultraviolet protection factor (UPF), UV-A and UV-B transmission, and UV protection rating according to AS/NZS 4399:1996 of PES and PES/CO fabrics after treatment with Sera® White P-N in a wide concentration range

Fabric	UPF	τ_{UVA}	τ_{UVB}	Stand. dev.	Stand. err.	UV protection	
PES	200.167	0.100	4.436	17.975	52.486	50 +	Excellent
PES-PN-0.1%	773.415	0.100	0.408	68.275	199.363	50 +	Excellent
PES-PN-0.5%	975.267	0.100	0.122	20.421	59.630	50 +	Excellent
PES-PN-1%	1000.000	0.100	0.100	0.000	0.000	50 +	Excellent
PES-PN-5%	1000.000	0.100	0.100	0.000	0.000	50 +	Excellent
PES-PN-10%	1000.000	0.100	0.100	0.000	0.000	50 +	Excellent
PES-PN-20%	1000.000	0.100	0.100	0.000	0.000	50 +	Excellent
PES/CO	113.499	0.100	6.434	8.125	23.724	50 +	Excellent
PES/CO-PN-0.1%	382.629	0.100	1.332	23.422	68.393	50 +	Excellent
PES/CO-PN-0.5%	868.491	0.100	0.208	24.270	70.869	50 +	Excellent
PES/CO-PN-1%	1000.000	0.100	0.100	0.000	0.000	50 +	Excellent
PES/CO-PN-5%	1000.000	0.100	0.100	0.000	0.000	50 +	Excellent
PES/CO-PN-10%	1000.000	0.100	0.100	0.000	0.000	50 +	Excellent
PES/CO-PN-20%	1000.000	0.100	0.100	0.000	0.000	50 +	Excellent

4. Conclusion

Treatment with FWA Sera® White P-N in wide concentration range, leads to multifunctionality - high whiteness, high brightness and protection against UV radiation. The fluorescence contributes to the high whiteness in optimal concentration, while in higher concentration quenching of fluorescence occurs. For PES fabric the optimal concentration of Sera® White P-N is 5 % whilst for PES/CO fabric is 1% owf.

Comparing the results of whiteness and UV protection on PES and on PES/CO fabrics it can be seen that slightly better results have been achieved on PES fabric. The reason for better whiteness is in better affinity of di(cyanstyryl) derivative to polyester fibres, and for UV protection additionally UV-R absorption by benzene rings in the polymer molecule. Since in PES/CO fabric is 35% of cotton fibres, whiteness degree and UPF are slightly lower. However, when treated with >1% owf of Sera® White P-N, maximum UV protection was achieved.

References

- [1] Tarbuk, A.; Grancarić, A. M. & Šitum, M.: Skin cancer and UV Protection. *AUTEX research journal*, **16** (2016) 1, pp. 19-28, ISSN 1470-9589
- [2] Gies, P. H. *et al.* Protection against solar ultraviolet radiation, *Mutation Research*, **422** (1998), pp. 15-22, ISSN 1383-5742
- [3] Hilfiker, R. *et al.* Improving sun protection factors of fabrics by applying UV- absorbers. *Textile Research Journal*, **66** (1996) 2, pp. 61-70, ISSN 0040-5175
- [4] Algaba, I., Riva, A. & Crews, P. C. Influence of Fiber Type and Fabric Porosity on the UPF of Summer Fabrics, *AATCC Review* **4** (2004) 2, pp. 26-31, ISSN 1532-8813
- [5] Grancarić, A. M. *et al.* UV Protection of Pretreated Cotton - Influence of FWA's Fluorescence, *AATCC Review* **6** (2006) 4, pp. 44-48, ISSN 1532-8813
- [6] Grancarić, A. M.; Tarbuk, A. & Botteri L.: Light Conversion and Scattering in UV Protective Textiles. *AUTEX research journal*, **14** (2014) 4, pp. 247-258, ISSN 1470-9589
- [7] Alebeid, O. K. & Zhao, T.: Review on: developing UV protection for cotton fabric, *The Journal of The Textile Institute*, **108** (2017) 12, pp. 2027-2039, ISSN 0040-5000
- [8] Tarbuk, A. *et al.*: Protection against UV-radiation Using a Modified Polyester Fabric (In Croatian), *Tekstil* **55** (2006) 8, pp. 383-394, ISSN 0492-5882
- [9] Zhou Y. & Cox Crews P.: Effect of OBAs and repeated launderings on UVR transmission through fabrics. *Textile Chem. Color.* **30** (1998) 11, pp. 19-24, ISSN 0040-490X

- [10] Dekanić T. *et al.*: Light Conversion for UV Protection by Textile Finishing and Care, in *Sunscreens: Properties, Role in Skin Cancer Prevention and Health Effects* (Ed. S. H. Sharp), ISBN 978-1-63482-160-5, New York : Nova Science Publishers, 2015, pp. 143-172.
- [11] Griesser, R. Assessment of whiteness and tint of fluorescent substrates with good inter-instrument correlation; *Color Res. Appl.* **19** (1994), 6, pp. 446-460, ISSN 0361-2317

Acknowledgment:



The work of doctoral student Ivana Čorak has been supported in part by the “Young researchers’ career development project – training of doctoral students” of the Croatian Science Foundation. Any opinions, findings, and conclusions or recommendations expressed in this material are those of the authors and do not necessarily reflect the views of Croatian Science Foundation.

This work has been supported in part by Croatian Science Foundation under the project UIP-2017-05-8780 HPROTEX.

This work is a result of Croatia-Serbia cooperation in science and technology 2019-2021 entitled “Bio-innovative polyesters”.

The authors wish to thank company DyStar for donating FWA for this research.

Authors:

Ivana ČORAK, mag. ing. techn. text.; Assist. Prof. Tihana Dekanić, PhD; Petra Kašaj, univ.bacc.ing.techn.text.;
Assoc. Prof. Anita Tarbuk, PhD (corresponding author)
University of Zagreb Faculty of Textile Technology
Prilaz baruna Filipovića 28a, 10 000, Zagreb
Phone: +385 1 3712 500

E-mail: ivana.corak@tff.unizg.hr
E-mail: tihana.dekanic@tff.unizg.hr
E-mail: anita.tarbuk@tff.unizg.hr

THE INFLUENCE OF MALEIC ACID CONCENTRATION ON THE BINDING OF CHITOSAN WITH COTTON CELLULOSE

Sandra FLINČEC GRGAC; Tea-Dora BIRUŠ; Anita TARBUK; Rajna MALINAR & Zbigniew DRACZYŃSKI

Abstract: Chitosan is an environmentally friendly agent used to achieve the antimicrobial properties of textiles. Due to the increasing demands on the stability of antimicrobial properties to multiple maintenance cycles, many authors are conducting research to permanently bind chitosan to the textile substrate. Aim of this study was to explore influence and persistence of the processing on cellulose textile substrates with an aqueous solution of chitosan using maleic acids in concentrations of 15 and 25 g/l with sodium hypophosphite monohydrate as catalyst. For the purpose of durability treated fabrics were washed according to ISO 6330:2012. The ability of maleic acid to crosslink chitosan with cellulose was tested before and after maintenance cycles using Fourier infrared spectrometry in the ATR technique (FTIR-ATR). The mechanical properties of the treated fabric were investigated before and after cycles of maintenance in accordance with ISO 13934-1. Maleic acid proved to be good crosslinking agent for chitosan and cellulose, regardless of applied concentration. The mechanical damage is higher in samples treated with a higher concentration of maleic acid due to the sensitivity of cotton to the action of acids.

Keywords: Cellulose, chitosan, maleic acid, FTIR-ATR, mechanical properties

1. Introduction

Chitosan is biopolymer available in nature and is cheap to be produced. It is an environmentally friendly agent which shows good biocompatibility, bio-absorbability, wound-healing, haemostatic, anti-infection, anti-bacterial, non-toxicity and adsorption properties and usually used to achieve the antimicrobial properties of textiles which can be specifically used for medical purposes. It is knowing the major problems of chitosan as an antimicrobial agent are its poor durability on textile fabrics due to its lack of strong bonding with fabrics [1,2]. In last few years' different agents for crosslinking chitosan and cotton were used, eg. glutaraldehyde, some inorganic salts, phenols and thiophenoles, antibiotics, and formaldehyde derivatives. However, most of them are controversial for the environment and/or humans. Polycarboxylic acids (PCAs) for crosslinking with chitosan and cotton fabric are the best choice [1].

Therefore, in this paper, the effect of maleic acid concentration on the binding of chitosan to sodium hypophosphite monohydrate as a catalyst, as well as its durability, were investigated.

2. Materials and Methods

100% cotton standard fabric by WFK, marked as 10A, made in accordance with DIN 53919 / ISO2267 was used. Chitosan is obtained from Tricomed, Łódź, Poland. The samples were ground in a PULVERISETTE 7 micromill which has the ability to grind hard, medium hard and soft materials to a fineness of 100 nm. In the process of crushing, ceramic balls with a diameter of 20 mm and a crushing time of 48 minutes with a rotation speed of 900 rpm were used. Thus, crushed chitosan was used in the process of processing cellulosic material. For the purpose of crosslinking of chitosan and cellulose was used maleic acid types from Scharlau, and sodium hypophosphite monohydrate, Sigma Aldrich as a catalyst.

All samples were kept 20 h in the bath and after that treated in microwave oven for 5 min at 80 W. Finishing process of the samples provide from pad-dry-cure method, with wet pick-up 100%, conductive drying was carried out at 100 °C for 2 minutes and thermocondensation at 150 °C for three minutes.

Treated fabrics were washed according to ISO 6330:2012 *Textiles - Domestic washing and drying procedures for textile testing*, up to 10 washing cycles, in a Wascator FOM71 CLS device in accordance with ISO 6330, 6N in program 58 with the addition of 20 g of standard detergent. Properties were determined after 3rd and 10th washing cycle. In Table 1 list of samples with associated labels is shown.

Table 1: List of samples with associated labels

Sample	Treatment	pH of bath
CO	100% cotton standard fabric marked WFK 10A	
CO_K1	Cotton treated with a bath containing 15% MA and chitosan	4.27
CO_K1_3W	Cotton treated with a bath containing 15% MA and chitosan, after 3 maintenance cycles	
CO_K1_10W	Cotton treated with a bath containing 15% MA and chitosan, after 10 maintenance cycles	
CO_K2	Cotton treated with a bath containing 25% MA and chitosan	3.67
CO_K2_3W	Cotton treated with a bath containing 25% MA and chitosan, after 3 maintenance cycles	
CO_K2_10W	Cotton treated with a bath containing 25% MA and chitosan, after 10 maintenance cycles	

The ability to bind chitosan with cellulose by maleic acid before and after washing cycles was tested using Fourier infrared spectrometry (Perkin Elmer, software Spectrum 100) in the Attenuated total reflection (FTIR-ATR) technique. For each sample, 4 scans were recorded at a resolution of 4 cm⁻¹ between 4000 and 380 cm⁻¹.

The mechanical properties (breaking force (*F*) and elongation(ϵ)) of the fabric were investigated before and after the treatment on a Tensolab Strength Tester (Mesdan S.p.A., Puegnago del Garda, Italy) in accordance with ISO 13934-1:2013 *Textiles — Tensile properties of fabrics — Part 1: Determination of maximum force and elongation at maximum force using the strip method*, with distance between clamps 100 mm, bursting speed 100 mm/min and pretension 2 N.

Mechanical damage was calculated according to ISO 4312:1989 *Surface active agents—Evaluation of laundering—Methods of analysis and tests for unsoiled cotton control cloth*:

$$U_m = \frac{F_0 - F}{F_0} \cdot 100 \quad (1)$$

where *Um* is mechanical damage (wear) [%], *F*₀ is breaking force of start fabric [N], and *F* is breaking force of treated and/or washed fabric [N].

The antimicrobial activity was determined according to AATCC TM 147-2016, *Antibacterial Activity Assessment of Textile Materials: Parallel Streak Method*. The activity was determined to Gram-positive bacteria *Staphylococcus aureus* ATCC 6538, Gram-negative bacteria *Escherichia coli* ATCC 8739 and microfungi-yeast *Candida albicans* ATCC 10231.

3. Results and Discussion

In this paper, the effect of maleic acid concentration on the binding of chitosan with cotton cellulose was investigated. Sodium hypophosphite monohydrate was used as a catalyst. For the purpose of durability testing, fabrics were washed up to 10 cycles. The ability of maleic acid to crosslink chitosan with cellulose was tested after treatment and after 3rd and 10th washing cycles using Fourier infrared spectrometry in the ATR technique (FTIR-ATR). The results of the spectral curves obtained by FTIR-ATR analysis of untreated 100% cotton material and the same after treatment are shown in Figures 1 and 2.

Spectral bands on treated and untreated samples at 3341 cm⁻¹ indicate racking in -OH groups that was altered in the treated samples due to overlap within the stretching of N-H group present in the chitosan in the same region. The spectral bands of the sample CO_K1 and CO_K2 indicate the appearance of symmetrical and asymmetric vibrations within the C-H bonds characteristic of polysaccharides at wave numbers 2946 cm⁻¹, 2889 cm⁻¹, and a peak at 2821 cm⁻¹ indicates a change in the methyl group. The peak at 2158 cm⁻¹ is more visible in the CO_K1 sample than in the CO_K2 sample and indicates the presence of a Si-H group that may be present in the chitosan due to the method of preparation. The peak at 1640 cm⁻¹ and 1644 cm⁻¹, respectively, in both treated samples has a lower intensity compared to untreated cotton, and occurs due to

the stretching of the C = O bond within the cellulose. It can be assumed that the change in intensity was due to the presence of residual N-acetyl groups present in chitosan.

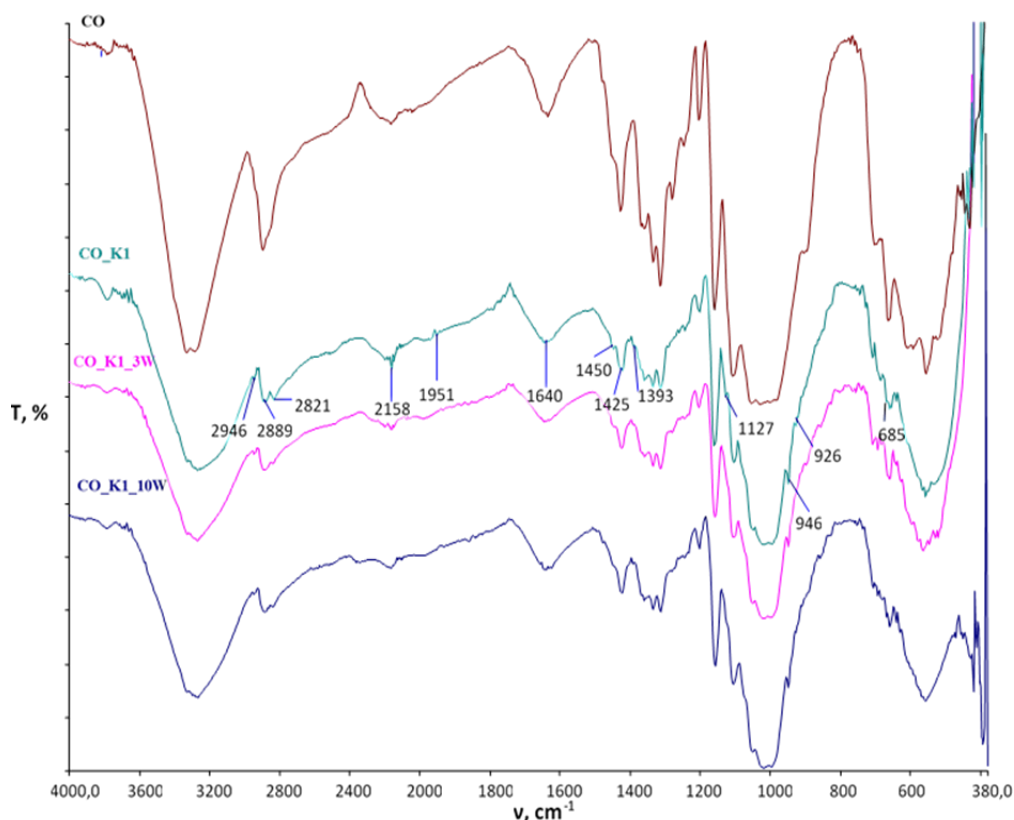

Figure 1: FTIR spectral bands of cotton treated with 15% MA with the addition of chitosan before and after maintenance cycles compared to untreated fabric

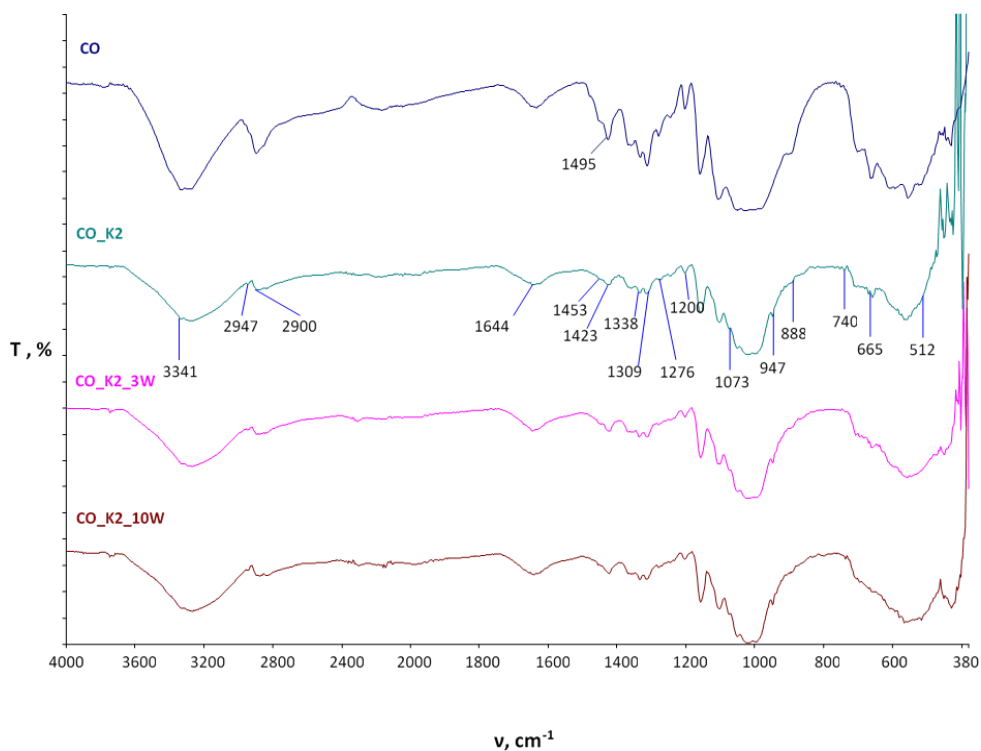

Figure 2: FTIR spectral bands of chitosan cotton treated sample with 25% MA before and after maintenance cycles compared to untreated fabric

At the wave number 1450 cm^{-1} and 1453 cm^{-1} , respectively, a peak was formed due to stretching within the CH_2 group, while at 1425 cm^{-1} , 1423 cm^{-1} and 1393 cm^{-1} , CH_3 groups were present along with CH_2 . According to the literature, the peak in the 946 cm^{-1} , 947 cm^{-1} , and 926 cm^{-1} wavelengths represents the binding of the P-O group to the trimethyl group that may be present in the chitin structure. At the wave number 1495 cm^{-1} in the case of untreated cotton fabric, a sharp peak is visible, formed by bending in the -OH plane from the -C-O-H group, which is much lower in intensity on chitosan treated cotton fabrics [3-7]. All shown physicochemical changes on the spectral bands of the treated samples after 3 and 10 washing cycles are clearly visible with a possible change in intensity and indicate a constant modification of the physicochemical properties of the treated samples.

The mechanical properties (breaking force and elongation) of the treated fabric were investigated before and after 3rd and 10th washing cycle in accordance with ISO 13934-1. The results are presented in Table 2. From the results of breaking force, mechanical damage was calculated according to ISO 4312. Results are presented in Table 3.

Table 2. Mechanical properties (breaking force (F) and elongation (ϵ)) of cotton samples before and after treatment and multiple maintenance cycles

Samples	F warp [N]	ϵ warp [%]	F weft [N]	ϵ weft [%]
CO	726	8.400	803	21.800
CO_K1	471	10.900	472	23.400
CO_K1_3W	480	13.587	424	23.210
CO_K1_10W	436	12.800	471	21.500
CO_K2	400	10.379	376	25.900
CO_K2_3W	453	12.100	358	23.900
CO_K2_10W	364	12.000	367	20.300

F - breaking force, ϵ - elongation

Table 3: Mechanical damage to cotton samples before and after treatment and multiple maintenance cycles

Samples	Mechanical damage of warp [%]	Mechanical damage of weft [%]
CO_K1	35.12	41.22
CO_K1_3W	33.88	47.20
CO_K1_10W	39.94	41.34
CO_K2	44.90	53.18
CO_K2_3W	37.60	55.42
CO_K2_10W	49.86	54.30

From the results in tab. 2-3 it can be seen that some mechanical damage has occurred since the values are 35-45% less depending of MA concentration. The damage was caused by finishing cotton fabric samples in an acidic medium. The acid damage to cellulose was greater in samples treated in a bath with a higher concentration of maleic acid.

In washing process, with heat and rinsing in water, the bonding between the MA and the two polymers is interrupted, and it is breaking. During the process of thermocondensation due to the heating of the MA, the anhydride is initially formed which is the reactive intermediate responsible for the networking of the MA with the cellulose, and analogue with chitosan. Addition of SHP as a catalyst promote an effective cross-linking between cellulose and chitosan by ester formation [1]. The results of antimicrobial efficacy of the samples before and after the treatments and multiple wash cycles shown in Table 4.

Table 4: Antimicrobial efficacy of samples

Samples	<i>Staphylococcus aureus</i>	<i>Escherichia coli</i>	<i>Candida albicans</i>
CO	-	-	-
CO_K1	-	-	+/-
CO_K1_3W	-	-	+/-
CO_K1_10W	-	-	+/-
CO_K2	-	-	+/-
CO_K2_3W	-	-	+/-
CO_K2_10W	-	-	+/-

From the results of antimicrobial efficacy presented in Table 4 is visible that the *Staphylococcus aureus* and *Escherichia coli* were present on all samples. The presence of *Candida albicans* on the surface of the treated samples was absent, but still the zone of inhibition was not achieved. However, since the *Candida albicans* was not present on or beneath the sample, it can be pointed out that this treatment gives only antimicrobial activity to micro fungi. This clearly indicates the need to modify the concentration ratios of chitosan in the bath, with the possibility for achieving better antimicrobial activity.

4. Conclusion

Chitosan is eco-friendly and safety substance which usually used for the medical applications like promoting tissue growth, accelerating wound-healing, bone regeneration, antimicrobial treatment etc. The binding stability of chitosan to cellulosic material by maleic acid was confirmed by FTIR-ATR analysis of samples CO_K1 and CO_K2 whose spectral bands indicate the resulting changes after processing and multiple maintenance cycles. Maleic acid proved to be good crosslinking agent for chitosan and cellulose, regardless of applied concentration. For a detailed interpretation of the mechanism of binding of chitosan to cellulose with maleic acid as a crosslinker in further research, samples will be analyzed for X-ray diffraction (XRD), Differential scanning calorimetry (DSC), Field Emission Scanning Electron Microscope with Energy Dispersive X-Ray Spectroscopy analysis (FE SEM-EDS) and others.

The mechanical damage occurred in all treated samples before and after maintenance damage is higher in samples treated with a higher concentration of maleic acid due to the sensitivity of cotton to the action of acids. However, this paper provides good indicators for achieving stronger binding of chitosan to cellulose, and further research will seek to modify the treatment process in order to reduce mechanical damage and obtain better antimicrobial efficacy.

Acknowledgment:

This work has been supported in part by Croatian Science Foundation under the project UIP-2017-05-8780 HPROTEX. The authors thank to company Tricomed SA, Łódź, Poland for chitosan donation.

References

- [1] Flinčec Grgac, S. et al: The Chitosan Implementation into Cotton and Polyester/Cotton Blend Fabrics, *Materials*, **13** (2020) 7, pp 1-18, doi:10.3390/ma13071616
- [2] Chellamani, K.P.; Vignesh Balaji, R.S. & Sudharsan, J.: Chitosan treated Textile substrates for Wound care applications, *Journal of Academia and Industrial Research*, **2** (2013) 2, pp 97 - 102 , ISSN 2278-5213
- [3] Gatahi, D et al: Effect of Biological Control Antagonists Adsorbed on Chitosan Immobilized Silica Nanocomposite on *Ralstonia solanacearum* and Growth of Tomato Seedlings, *Advances in Research*, **6** (2016) 3; pp 1-23, ISSN 2348-0394
- [4] Queiroz, M. F. et al: Does the Use of Chitosan Contribute to Oxalate Kidney Stone Formation?, *Marine Drugs*, **13** (2015), pp 141-158, ISSN 1660-3397
- [5] Geçer, A. et al: Trimethyl Chitosan Nanoparticles Enhances Dissolution of the Poorly Water Soluble Drug Candesartan-Cilexetil, *Macromolecular Research*, **18** (2010) 10, pp 986-991, ISSN 15985032
- [6] Mendes, J. F. et al: Biodegradable polymer blends based on corn starch and thermoplastic chitosan processed by extrusion, *Carbohydrate Polymers*, **137** (2016), pp 452-458, ISSN 0144-8617
- [7] Pawlak, A.; Mucha, M.: Thermogravimetric and FTIR studies of chitosan blends, *Thermochimica Acta*, **396** (2013) 1-2, pp 153-166, ISSN 0040-6031

Authors:

Assoc. Prof. Sandra FLINČEC GRGAC, PhD (corresponding author)
Tea-Dora Biruš, Assoc. Prof. Anita TARBUK, PhD, Rajna MALINAR
University of Zagreb Faculty of Textile Technology
Prilaz baruna Filipovića 28a, 10 000 Zagreb, Croatia
Phone: +(385) (01) 4877 355
Phone: +(385) (99) 1936 836
Phone: +(385) (01) 4877 352
Phone: +(385) (01) 4877 359

E-mail: sflincec@tff.hr
E-mail: t.d.birus@gmail.com
E-mail: anita.tarbuk@tff.hr
E-mail: rmalinar@tff.hr

Prof. Zbigniew DRACZYŃSKI, PhD
Faculty of Material Technologies and Textile Design, Technical University of Lodz,
ul. Zeromskiego 116, 90-924 Łódź, Poland

E-mail: zbigniew.draczynski@p.lodz.pl

IMPACT OF WET TREATMENTS ON SHIELD EFFECTIVENESS OF NICKEL/COPPER COATED FABRIC

Tanja PUŠIĆ; Bosiljka ŠARAVANJA; Krešimir MALARIĆ & Silvia BEŠLIĆ







Abstract: Shield properties of nickel/copper coated fabric were analysed before and after wet treatments with liquid detergent labeled for wet treatments of electrically conductive textiles. Nickel/copper coated fabric was treated with a detergent by soaking and tamping procedures. The electromagnetic shield effect of a protective Ni/Cu fabric before and after 1, 3, 5, 7 and 10 treatment cycles was measured at the frequencies of 0.9 GHz, 1.8 GHz and 2.4 GHz. The results have shown that applied procedures of soaking and tamping with a functional detergent over 10 cycles reduced the protective properties of a Ni/Cu coated fabric.

Key words: fabric, shield effect, wet treatments, liquid detergent

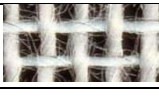
1. Introduction

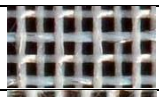
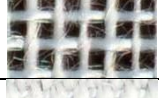
Body shielding against electromagnetic microwave radiation is possible by using of textiles with protective properties, placed between the body and the device that is the source of the radiation [1, 2]. In addition to human body protection, textiles with shielding properties against electromagnetic (EM) interference prolong the lifetime and efficiency of electronic devices. Electronic components embedded in the textiles monitor human body physiological parameters (heart rate, breathing rhythm, blood pressure, temperature etc.) creating added value, thereby expanding the range of options for production of shielding cloth as well as other shielding equipment. Functional textiles with electro conductive elements possess shielding properties against EM radiation excite the interest of scientists, textile industry and users [1-9]. Overview of shielding fabrics designed for technical, decorative and clothing applications is presented in Table 1.

Table 1: Overview of shielding fabrics supplied by YSHIELD GmbH [10]

SE fabric	Microscopic image	Composition	Q (g/m ²)	SE (dB), (f = 1 GHz)	Application
<i>Ultima</i>		82% cotton, 17% copper, 1% silver	85	41	Decorative textiles (curtain)
<i>Naturell</i>		82% eco-cotton, 17% copper, 1% silver	70	38	Decorative textiles (curtain)
<i>Naturell Ultra</i>		81% cotton, 17% copper, 1% silver, 1% carbon	115	40	Decorative textiles (curtain, canopy)
<i>Voile</i>		83% polyester, 16% copper, 1% silver	55	36	Decorative textiles (net curtain)
<i>Evolution</i>		91% polyester, 8.5% copper, 0.5% silver	80	30	Decorative textiles (curtain)
<i>Wear</i>		90% cotton, 9.5% copper, 0.5% silver	70	30	Cloth (sewing benefits)
<i>New-Daylite</i>		78% polyester, 21% copper, 1% silver	65	25	Decorative textiles (curtain, canopy)
<i>Silver-Tulle</i>		80% polyamide, 20% silver	40	50	Decorative textiles (curtain, canopy)
<i>Silver-Twin</i>		50% cotton, 35% polyester, 15% silver	150	57	Decorative textiles (curtain, canopy), bags, thicker cloth

Steel-Twin		68% polyester, 17% cotton 15% inox	190	35	Floor mats, decorative textiles (curtain, canopy)
Steel-Gray		40% cotton, 30% polyester, 30% inox	120	35	Decorative textiles -curtain, cloth, bed linen, floor mats, wall groundings
Silver-Elastic		80% Span- dex, 20% silver	130	50	High elasticity cloth
Silver-Silk		80% polyamide, 20% silver	45	60	Cable protections, Wall groundings, bags
Silver-Grid		95% cotton 4% polyester 1% silver	130	13	Groundings, decorative textiles (bed linen, bed sheets, mats)

According to a care label, a washing process with a special Texcare liquid detergent is proposed for SE functional fabrics [10]. Ingredients in detergent formulation are intended to preserve EM shielding properties as more as possible, what means prolong lifetime and functionality of fabrics. Washing tests with Texcare detergent through 50 times at 30°C on two washing machines parallel (Bosch and Samsung) and averaged SE results are presented in Figure 1 [10]. The orange column indicates SE measured at 1 GHz before washing and each subsequent grey column indicates the protective effect of fabrics after the 10th, 20th, 30th, 40th and 50th washing cycles. Measurements of the degree of EM radiation protection were performed in accordance with ASTM D4935-10 [11].

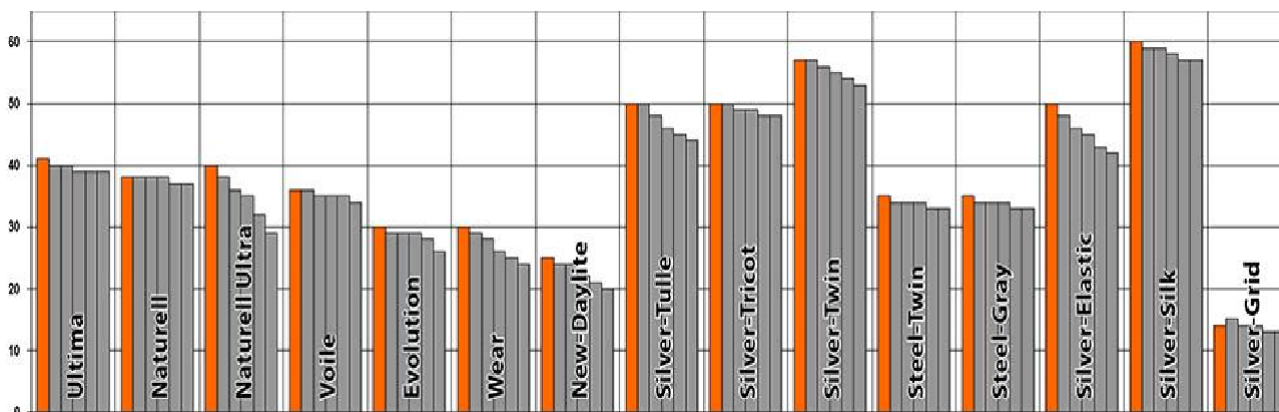

Figure 1: SE of functional fabrics before and after 10, 20, 30, 40 and 50 washing cycles [10];
x axis: number of washing cycles;
y axis: SE (dB)

The diagram orange column shows that the functional materials shown have different degrees of protection depending on the content and type of metal. Multiple washing cycles slightly affected the decrease in the protective properties of all materials except for the Silver - Grid material, which after 10 washing cycles possesses better protective properties than before washing. Naturell Ultra had the greatest difference in protective effect before and after 50 washes. Results showed that all the tested materials have good washing results. They also recommended an air drying because tumbling into the dryer can damage protective textiles. If the dryer is used, then it must be at low temperatures [10].

This study is focused on the impact of chemistry and mechanical agitation on shield properties of the conductive Ni/Cu coated polyester fabric before and after wet treatments. It is known that textile care processes in wet are performed through the impact of chemistry, mechanics, temperature and time, presented by Sinner cycle [12], Figure 2.

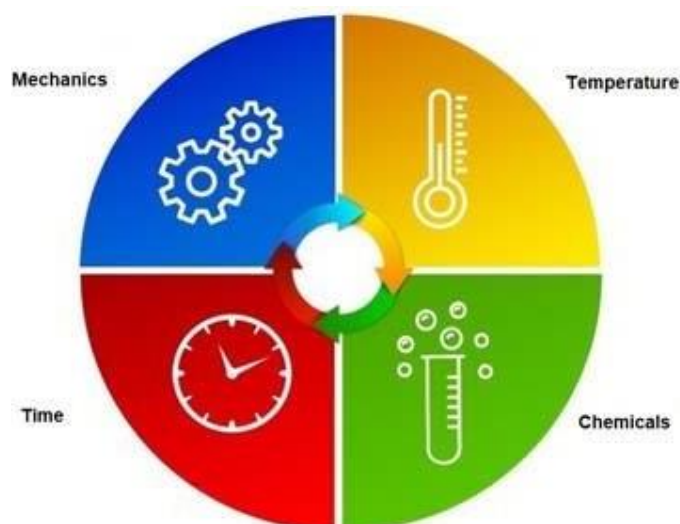

Figure 2: Factors of the Sinner circle [13]

Polyester fabric coated with Ni/Cu, having superior tarnish, corrosion resistance, high conductivity and shielding performance is selected for investigation. The fabric was treated with a liquid detergent by soaking and tamping procedures, where mechanical agitation varied. The electromagnetic SE of this protective Ni/Cu fabric before and after 1, 3, 5, 7 and 10 treatment cycles was measured at the frequencies of 0.9 GHz, 1.8 GHz and 2.4 GHz.

2. Experimental part

2.1. Material

Characteristics of conductive polyester fabric in rip stop weave coated with Ni/Cu provided by YSHIELD GmbH & Co supplier are specified in Table 2.

Table 2: Specification and micrograph of a conductive fabric Ni/Cu coated

Parameter (unit)	Value	Micrograph (235x)
Fabric thickness (mm)	0.08	
Mass per unit area (g/m ²)	90	
Surface resistivity (Ω/m ²)	0.03	

2.2 Procedures

Since a conductive Ni/Cu coated polyester fabric is intended for drapes and wall coverings, two techniques have been selected for wet treatment through 10 cycles. The first one, soaking (S) was chosen for drape application of conductive Ni/Cu fabric while tamping (T) as the second one was chosen for wall coverings application.

Sample of Ni/Cu fabric in dimensions of 1 m x 1m was treated by soaking (S) in the tub with bath of volume 4.0 L, prepared by dosing of 7.7 ml/L detergent Texcare liquid detergent, supplied by YSHIELD GmbH & Co. According a supplier specification, ingredients in a detergent formulation should preserve EM shielding properties of textiles as more as possible, prolong their lifetime and functionality. Surface active substances (soap from rapeseed oil, sugar surfactant and coconut oil alcohol sulphate) with other ingredients in a formulation reflect on pH value of a washing bath which is 7.65. After soaking in the bath through 20 minutes the fabric was three times rinsed with soft water and air dried.

Tamping (T) of both sides conductive fabric was performed by sponge saturated with a bath (7.7ml/L) during 15 minutes. After tamping the material was rinsed three times with soft water and air dried.

2.3. Methods

The electric field was measured using the method developed at the University of Zagreb Faculty of Electrical Engineering and Computer Sciences, at the Microwave laboratory, Department of Radio-communications. Following the recommendations of the international standards ASTM D-4935-89, IEE-STD 299-97 and MIL STD 285 [14-16] a measuring setup is designed. It consisted a signal generator, a horn antenna and barrier into which the fabric was positioned [3]. The electromagnetic shield effect and efficiency on the face (F) and reverse (R) side of conductive fabric coated with Ni/Cu before and after multiple treatment cycles was measured at the frequencies of 0.9 GHz, 1.8 GHz and 2.4 GHz. Shield effect (SE (dB)) of conductive fabrics was calculated according to the following equation:

$$SE = 20 \log \frac{E_0}{E_1} \quad (1)$$

where E_0 is the level of the received field without shield and E_1 is the level of electric field with a shield.

Appearance of Ni/Cu coated functional fabrics before and after 10 cycles of soaking and tamping were subjective evaluated.

3. Results and discussion

Shield effectiveness (SE) of polyester Ni/Cu coated fabric before and after soaking in the tub measured at frequencies of 0.9 GHz; 1.8 GHz and 2.4 GHz are shown in Table 3.

Table 3: SE of polyester fabric coated with Ni/Cu, before and after soaking cycles, measured at the frequencies of 0.9 GHz, 1.8 GHz and 2.4 GHz

Soaking cycles	SE (dB)					
	0.9 GHz		1.8 GHz		2.4 GHz	
	F	R	F	R	F	R
-	3.14	3.45	11.98	12.21	12.71	12.92
1 st	2.75	2.99	9.83	10.18	12.26	13.31
3 rd	2.03	2.28	7.42	7.81	10.38	10.62
5 th	1.81	1.98	6.30	6.69	7.88	8.22
7 th	1.52	1.66	5.77	6.15	7.51	7.73
10 th	1.38	1.49	5.21	5.63	7.07	7.33

Shield effectiveness (SE) of polyester Ni/Cu coated fabric before and after tamping in the tub measured at frequencies of 0.9 GHz; 1.8 GHz and 2.4 GHz are shown in Table 4.

Table 4: SE of polyester fabric coated with Ni/Cu, before and after tamping cycles, measured at the frequencies of 0.9 GHz, 1.8 GHz and 2.4 GHz

Tamping cycles	SE (dB)					
	0.9 GHz		1.8 GHz		2.4 GHz	
	F	R	F	R	F	R
-	3.14	3.45	11.98	12.21	12.71	12.92

1 st	2.58	2.80	8.16	8.54	11.60	11.83
3 rd	2.23	2.52	7.07	7.28	9.54	9.76
5 th	1.94	2.15	5.38	5.67	6.81	7.07
7 th	1.63	1.82	4.77	5.05	5.74	6.11
10 th	1.35	1.53	4.32	4.65	5.28	5.56

Shield effectiveness of PES fabric coated with Ni/Cu after 10 cycles of tamping and soaking presented in Table 3 and Table 4 indicated that protective properties of this fabric were better preserved in the soaking than in the tamping procedure.

Ten soaking cycles caused reduction of SE at all measured frequencies. The loss of protective properties PES fabric measured from face and reverse side is not the same. Face sided PES fabric with Ni/Cu lost 56% at 0.9 GHz, 51% at 1.8 GHz and 41% at 2.4 GHz. The impact of 10 soaking cycles on the reverse side of PES fabric coated with Ni/Cu is similar, 51% at 0.9 GHz, 50% at 1.8 GHz and 36% at 2.4 GHz.

The effect of 10 tamping cycles on the drop of SE faced PES fabric with Ni/Cu is also proved, 57% at 0.9 GHz, 63% at 1.8 GHz and 58% at 2.4 GHz. The effect of tamping the reverse sided PES fabric coated with Ni/Cu was similar to the face one, 55% at 0.9 GHz, 61% at 1.8 GHz and 57% at 2.4 GHz.

The tamping significantly impairs the SE properties of PES fabric coated with Ni/Cu than soaking procedure. This difference is not caused by chemical impact in a Sinner cycle, since the same concentration of Texcare detergent was used for soaking and tamping procedures. However, more pronounced mechanical agitation in the tamping process caused a reduction in the SE value. This is expected since the tamping process is performed by a cyclic movement of a sponge over the surface of the functional fabric.

Appearance of PES fabric coated with Ni/Cu before and after wet treatments is presented by photo images in Figure 3.

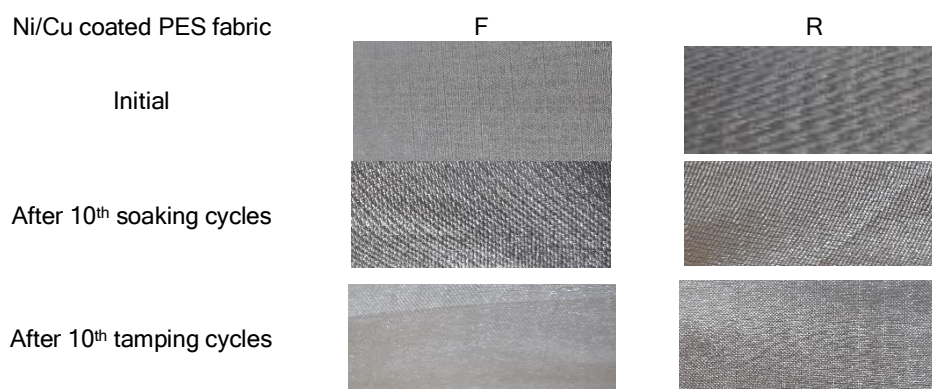

Figure 3: Appearance of PES fabric coated with Ni/Cu - impact of 10 cycles tamping and soaking

Photos of samples before and after 10 tamping and soaking cycles indicate on change in appearance, Figure 3. Superior tarnish as a specific characteristic of PES fabric coated with Ni/Cu is partially lost in tamping, so this evaluation criteria also proved that soaking is more gentle than tamping procedure.

4. Conclusions

Wet treatments of conductive polyester fabric coated with Ni/Cu with special liquid Texcare detergent, where techniques tamping and soaking were selected as reasonable for drapes and wall coverings. The results presented indicate that the shield effectiveness of polyester Ni/Cu fabric measured at frequencies 0.9 GHz, 1.8 GHz and 2.4 GHz were diminished with increased number of treatment cycles. The intensity of the changes depends upon mechanical agitation in wet treatments technique and measurement frequency. Ten tamping cycles resulted in more pronounced SE reduction than it was the case with soaking of conductive Ni/Cu fabric. Higher share in mechanical input in tamping is a dominant factor for drop in SE properties of functional

conductive fabric. SE properties of conductive polyester fabric coated with Ni/Cu fabric can be preserved by careful selection of textile care process, where is necessary to apply a gentle mechanical agitation.

Acknowledgement

This work has been fully supported by Croatian Science Foundation under the project HRZZ-IP-2018-01-7028.

References

- [1] Shangcheng X, et al. Exposure to 1800 MHz Radiofrequency Radiation Induces Oxidative Damage to Mitochondrial DNA in Primary Cultured Neurons. *Brain Research*, **Vol.13.** (2010), No.131, pp.189-196. ISSN: 0006-8993
- [2] Maity S, et al. Textiles in Electromagnetic Radiation Protection. *Journal of Safety Engineering* **Vol. 2.** (2013), No. 2, pp. 11-19. ISSN: 2325-0003
- [3] Malarić K.: *EMI Protection for Communication Systems*, Boston, USA, Artech House, 685 Canton Street, Norwood, MA 02062, 2010, ISBN 13: 978-1-59693-313-2
- [4] Šaravanja B, et al. Impact of Dry Cleaning on the Electromagnetic Shield Characteristics of Interlining Fabric, *Fibres Textiles Eastern Europe*, **Vol. 23.** (2015), No. 1, pp.104-108. ISSN 1230-3666
- [5] Šaravanja B, et al. Shield Effect of Functional Interlining Fabric. *AUTEX research journal*, **Vol. 15.** (2015), No. 2, pp. 93-98. ISSN 1470-9589
- [6] Malarić, K.; Šimunić, D.; Zenter, R.: *Ekonomija i ekologija radiokomunikacijskih sustava*, Sveučilište u Zagrebu Fakultet elektrotehnike i računarstva, 2016, Zagreb, ISBN 978-953-6976-15-7.
- [7] Liu Z., et al. Parameter Description of the Surface Metal Fiber Arrangement of Electromagnetic Shielding Fabric. *Fibres Textiles Eastern Europe*, **Vol. 25,** (2017), No. 2, pp 62-67. ISSN 1230-3666
- [8] Ceven E.K., et al. Evaluation of electromagnetic shielding effectiveness of fabrics produced from yarns containing metal wire with a mobile based measurement system. *Industria Textile*, **Vol. 68,** (2017), No. 4, pp. 289-295. ISSN: 1222-5347.
- [9] Sonehara M, et al. Preparation and Characterization of Nanofiber Nonwoven Textile for Electromagnetic Wave Shielding. *IEEE Transactions on Magnetics*, **Vol. 44.** (2008), No. 11, pp. 3107 - 3110. ISSN 0018-9464. Electronic ISSN 1941-0069.
- [10] YIELD EMR - Protection Catalog, <https://www.yshield.com/en/yshield-shielding-products/>, Accessed 2019-05-26
- [11] ASTM Standard D4935-10 Test Method for Measuring the Electromagnetic Shielding Effectiveness of Planar Materials, 2010.
- [12] Soljačić, I.; T. Pušić: *Njega tekstila - I dio*, Zagreb, Tekstilno-tehnološki fakultet, 2005. ISBN 953-7105-09-1
- [13] Available from: <http://molletta.ru/kto-pridumal-krug-sinnera/>, Accessed: 2019-05-22.
- [14] MIL-STD-285, Military Standard: Attenuation Measurements for Enclosures, Electromagnetic Shielding, 1956.
- [15] IEEE STD 299 Standard Method for Measuring the Effectiveness of Electromagnetic Shielding Enclosures, 2006, 299.
- [16] ASTM D 4935-99 Standard Test Method for Measuring the Electromagnetic Shielding Effectiveness of Planar Materials, 1999.

Authors:

Prof. Tanja PUŠIĆ, PhD. (corresponding author)
Assist. prof. Bosiljka ŠARAVANJA, PhD.
Silvia BEŠLIĆ, mag. ing. techn. text.
University of Zagreb Faculty of Textile Technology
Prilaz baruna Filipovića 28a, HR-10000 Zagreb, Croatia
Phone: +(385) (1) 48 77 354 Fax: +(385) (1) 48 77 354

E-mail: tanja.pusic@tff.unizg.hr
E-mail: bosiljka.saravanja@tff.unizg.hr
E-mail: silvia.beslic@gmail.com

Prof. Krešimir MALARIĆ, PhD.
University of Zagreb Faculty of Electrical Engineering and Computing, Zagreb
Unska 3, HR-10000 Zagreb, Croatia
Phone: +(385) (1) 6129 789 Fax: +(385) (1) 6129 789

E-mail: kresimir.malacic@fer.hr

THIN LAYER CHROMATROGRAPHICAL DETERMINATION OF METALS USED AS ANTIBACTERIAL COMPONENTS ON BIODEGRADABLE POLYMERS

Iva REZIĆ; Lela MARTINAGA; Mislav MAJDAK & Maja SOMOGYI ŠKOC

Abstract: Metal and metal oxide nanoparticles provide excellent antimicrobial, water resistance and protective properties so they are today one of the most important antimicrobial reagents in the textile industry. Therefore, extraordinary antimicrobial activity of metals and metal oxides receives significant global interest in the development of new products. The antimicrobial activity of the nanoparticles is the result of their very small diameters, which are far below the range of the microorganisms' dimensions. Such nano-sized metals and metal oxides can interact with both bacterial surfaces and/or with the bacterial core, after they enter inside the bacterial cell showing activity against different microorganisms, including Gram-positive and Gram-negative bacteria, as well as on spores that are resistant to high temperature and high-pressure. Different biodegradable polymers containing nanoparticles in their surface coatings are used in many protective materials. In this work, thin layer chromatography (TLC) was applied as a simple, rapid and effective method for determination of metals in a form of metal ions which are used as efficient antibacterial compounds in protective coatings on biodegradable polymers. The development was performed by acetonitrile: hydrochloric acid: water= 72: 25: 23 (v/v), on thirty different stationary phases. For visualization, NH₃ vapors and UV light (254 and 366 nm) were applied. Results proved that spots of different compounds (namely Ag, Al, Au, Co, Cr, Cu, Fe, Ni, Mn, Pb, Zn and others) can easily be determined. Proposed TLC method is therefore an excellent choice for identification and quantification of many metals used as antimicrobial compounds present in coatings on wide variety of different biodegradable polymers.

Keywords: thin layer chromatography; antibacterial coating; biodegradable polymers; nanoparticles;

1. Introduction

1.1 Antimicrobial properties of metal nanoparticles

Textile industry uses metal ions and metal nanoparticles as antimicrobial reagents in wide variety of products (sports clothing, uniforms, medical materials and other protective items). The antimicrobial activity of metal nanoparticles is the result of their size which is in the range of 1 to 100 nm. This size range is small enough to make nanoparticles available to interact with the microorganisms on their surfaces and/or with their cores [1]. Metal nanoparticles show strong antimicrobial activity not only on bacteria, but as well as on spores resistant to high temperature and high-pressure [2]. Therefore nanoparticles are used on textile materials in order to obtain reinforced antibacterial materials resistant to tear. In addition to antibacterial properties, anti-odor, self-cleaning and medicine textiles are achieved.

Due to the protective properties described above, metals like silver, gold and other nanoparticles are often found on the surface of textile materials, not only modern items, but also historical materials contained metal layers in a form of metal stripes [3]. Such metal stripes were used to protect material and improve its mechanical purposes of fibers around which it was wrapped. The problem on historical material is the fact that antibacterial firm coating made of metal could in specific environmental conditions create discoloration or staining. Since historical textile materials are made of silk, or other natural fibers are very sensitive if old, the processes can lead to the full degradation of historical valuable natural heritage materials [4, 5].

Chemical characterization of antibacterial protective layers in a form of thin layer on a stripe or small size nanoparticle is important for technological and industrial aspects. The methodology usually proposed for this purpose is the scanning electron microscopy equipped with the EDX detector (SEM-EDX). This instrument provides a fast and non destructive analysis of samples [7-13].

In addition to microscopic analysis such is the SEM-EDX, spectroscopy methods are combined to this method in the analysis of antimicrobial layers on different materials. Most popular are FTIR, inductively coupled plasma - optical emission spectroscopy (ICP-OES) and inductively coupled plasma - mass spectroscopy (ICP-MS) [14-17]. Our work proposes application of chromatography procedure - the thin layer chromatography (TLC) in analysis of textile samples containing antimicrobial metals on their surfaces, including historical materials

(with metal threads) and modern medical textiles (containing metal nanoparticles). TLC can provide fast preliminary information on major and minor metal components which is useful for monitoring the metals that are present as the matrix [19-28].

2. Experimental

2.1 Samples

Samples investigated were metal and semimetal ions, namely Ag^+ , Al^{3+} , As^{2+} , Au^{2+} , B^+ , Ba^{2+} , Be^{2+} , Bi^{3+} , Br , Ca^{2+} , Cd^{2+} , Co^{2+} and Cr^{3+} . All samples were prepared for the analysis wither by dissolving 0.0500 g of the sample salt in 5 mL of concentric nitric acid or water, or using pre-prepared standard solutions for the metal development.

2.2 Reagents

All reagents used were of p.a. purity. Pure 1000 mg/mL standard solutions of investigated metals and semimetals (Ag^+ , Al^{3+} , As^{2+} , Au^{2+} , B^+ , Ba^{2+} , Be^{2+} , Bi^{3+} , Br , Ca^{2+} , Cd^{2+} , Co^{2+} and Cr^{3+}) were obtained from Merck Company. Other reagents used were concentrated hydrochloric and nitric acids, concentrated ammonia and acetonitrile which were obtained from the Merck Company. The glassware were properly washed and cleaned in mineralized water.

2.3 Thin layer chromatography

Antimicrobial layers containing metals in a form of thin layers or nanoparticles can contain many different metals in their structure. In this work 13 different metal ions were analyzed by the thin layer chromatography. In our previous work we have developed and optimized a ternary mobile phase for separation and determination of 6 different metals from their mixture [19]. In this work we have broadened the range of interest in order to test 13 metals which are often found on textiles.

The analysis was performed in the following manner: firstly the pure metal ion standards were analyzed. The few micro liters of standard solutions (1 to 5 micro liters) were spotted on 10 × 20 cm TLC cellulose pre-coated plates (Merck, Darmstadt, Germany) by glass capillary. Development was made only after the saturation of the chromatographic chamber was achieved, for which 25 minutes of saturation took place. The development was carried out in the Camag chromatographic chamber by the ascending technique to 16 cm distance. Mobile system acetonitrile - hydrochloric acid – water (72: 25: 23) was chosen as the mobile phase since it was the optimal developer resulting from our previous work [19].

After the development, the plates were dried on the air and afterwards exposed to ammonia vapors. The chromatograms with spots occurred after 37 minutes of the development.

R_F factor was the mathematical operator that is used in thin layer chromatography to distinguish the position of different spots achieved from the analysis of different samples. It is calculated by using the following formula:

$$R_F = \frac{l_i}{l_0}, \quad (1)$$

The R_F factor presents the ratio between the distances reached by the samples (l_i) and the mobile phase (l_0). Obtained results for all 13 elements and their calculated R_F factors are presented in *Table 1* and in *Figure 1*.

3. Results

Results of the thin layer chromatography analysis are presented in *Tables I* and *Figure 1*. The results of all investigated metal ions are presented, and although the preliminary experiments included testing more than 25 different stationary phases, in this work the results achieved on the cellulose plate is presented. Preliminary experiments proved that cellulose layer is an excellent choice for the analysis of metal ions.

Table 1: Spot position on *Cellulose F*, producer KEMIKA, precoated plates, developed under optimal conditions under the front distance of 8 cm

Metal ion	Spot beginning, [mm]	Spot distance [mm]	Spot width [mm]
Ag ⁺	0.3	3.4	5.2
Al ³⁺	0.7	2.4	4.3
As ²⁺	0	0	0
Au ²⁺	2.5	4	3.1
B ⁺	1.5	3.7	4.0
Ba ²⁺	2.9	4.2	2.4
Be ⁺	0	0.9	2.7
Bi ³⁺	0	0	0
Br ⁻	1.8	3.7	3.7
Ca ²⁺	1.5	3.3	4.0
Cd ²⁺	3.3	3.9	1.3
Co ²⁺	3.6	4.8	2.4
Cr ³⁺	1.1	3.2	4.4

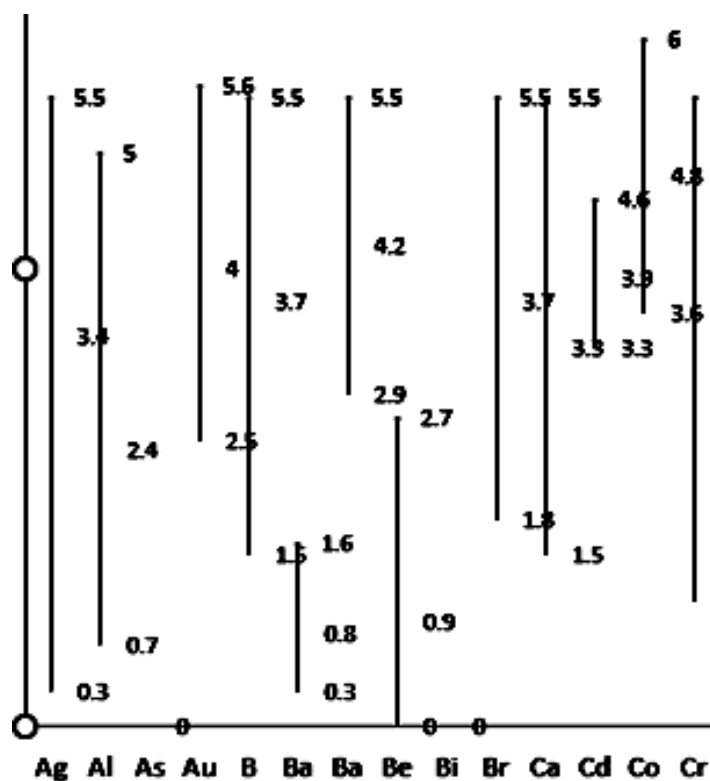
Figure 1: Spot position, width and overlapping of investigated metal ions: Ag⁺, Al³⁺, As²⁺, Au²⁺, B⁺, Ba²⁺, Be²⁺, Bi³⁺, Br⁻, Ca²⁺, Cd²⁺, Co²⁺ and Cr³⁺ detected on *Cellulose F*, producer KEMIKA, precoated plates, developed under optimal conditions under the front distance of 8 cm

4. Discussion

The most important metal nanoparticle on textile is silver nanoparticle, and it can be found in more than 25% of all products with nanoparticles in the world market. Therefore this element was the first choice for creating the thin layer chromatographically method for its investigation. Other elements were chosen due to their application in wide variety of textile products. It must be emphasized that it is extremely important to determine the metals present in textile samples in order to assess their quality, antimicrobial efficiency, durability and resistance to environmental conditions.

Therefore the results of the TLC analysis were thoroughly investigated. The spot position was determined through the three parameters: the beginning of the spot, the distance from the base line, and the spot width. Based on those results the R_F parameters were calculated, and those results are presented in Table 2.

Table 2: R_F of different spots obtained on stationary phase *Cellulose F*, producer KEMIKA, precoated plates, developed under optimal conditions under the front distance of 8 cm

Metal ion	Spot beginning, [mm]	Spot distance [mm]	R_F parameters
Ag ⁺	0.3	3.4	0.43
Al ³⁺	0.7	2.4	0.30
As ²⁺	0	0	0.00
Au ²⁺	2.5	4	0.50
B ⁺	1.5	3.7	0.46
Ba ²⁺	2.9	4.2	0.53
Be ⁺	0	0.9	0.11
Bi ³⁺	0	0	0.00
Br	1.8	3.7	0.46
Ca ²⁺	1.5	3.3	0.41
Cd ²⁺	3.3	3.9	0.49
Co ²⁺	3.6	4.8	0.60
Cr ³⁺	1.1	3.2	0.40

As can be seen from the Table 2, in a group of 13 investigated metal ions, some of them interfere. Those are: *i)* As²⁺ and Bi³⁺ with the R_F value of 0.00, and *ii)* B⁺ and Br with the R_F value of 0.46. This means that those two pairs of metal ions cannot be separated by one dimensional thin layer chromatography, but instead the two dimensional thin layer chromatography should be applied, which is done in a way to take the same plate and turn it around for 90 degrees and repeat the process of development on previously described manner.

Two dimensional chromatography might be helpful also in the analysis of mixture samples which would contain Cr³⁺ (R_F value of 0.40), Ca²⁺ (R_F value of 0.41), and A⁺ (R_F value of 0.43) in higher amounts which would make the spots too wide to be separated by one dimensional thin layer chromatography. Such analysis is highly recommended for the analysis of antimicrobial coatings such is the product shown in Figure 2.

Nanoparticles

Breathable polymer

Biodegradable surface

Nanoparticles

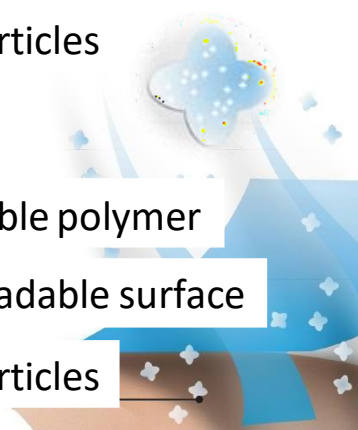

Figure 2: Commercial product containing silver nanoparticles in order to achieve protective properties [29]

Protective properties of metal and metal oxide nanoparticles include excellent antimicrobial, water resistance and protective properties. For this reason today they can be found as some of the most widely used antimicrobial reagents in the textile industry. Moreover, their extraordinary antimicrobial activity receives significant global interest in the development of new products. Figure 2 shows similar product in which the breathable polymer is coated with the antimicrobial nanoparticles. Different biodegradable polymers containing nanoparticles in their surface coatings are used in many protective materials. The mechanism of this antimicrobial activity is very interesting – it is attributed to the nanoparticles' diameters, which are far below

the range of the microorganisms' dimensions. Such dimensions can easily interact with both bacterial surfaces and/or with the bacterial core, after they enter inside the bacterial cell. It is therefore not surprise that they show activity against different microorganisms, including Gram-positive and Gram-negative bacteria, as well as on spores that are resistant to high temperature and high-pressure.

5. Conclusions

Thin layer chromatography proved to be very useful method for investigation of major and minor metal components which are present on the surface of textile samples, since it is fast, reliable and not expensive procedure. Therefore it can be recommended as an optimal method for determination of metals present both in modern antimicrobial textiles, as well as historical textile samples. The information on trace metals or metals that mutually interfere, and which are both present in samples of mixtures of metal ions, can be improved by using the two dimensional chromatography, which is planned for our future experiments.

Acknowledgements

This work was financially supported by the Croatian Science Foundation, project IP-2019-04-1381 under title „Antibacterial coating for biodegradable medicine materials ABBAMEDICA“. Any opinions, findings and conclusions or recommendations expressed in this material are those of the authors and do not necessarily reflect the views of Croatian Science Foundation.

References

- [1] Seil J.T., Webster T.J.; Antimicrobial applications of nanotechnology methods and literature; *International Journal of Nanomedicine* **Vol.** 7 (2012): 2767- 2781, ISSN: 1178-2013
- [2] Azam, A., Ahmed, A.S., Oves, M., Khan, M.S., Habib, S.S., Memic, A; Antimicrobial activity of metal oxide nanoparticles against Gram-positive and Gram-negative bacteria a comparative study; *International Journal of Nanomedicine* **Vol.** 7 (2011): pp. 6003-6009, ISSN: 1178-2013
- [3] Batcheller, J., Hacke, A.M., Mitchell, R., Carr, C.M.; Investigation into the nature of historical tapestries using time of flight secondary ion mass spectrometry (TOF-SIMS); *Applied Surface Science*, **Vol.** 19 (2006): pp. 7113-7116. ISSN: 0169-4332
- [4] Hacke, A.M., Carr, C.M.; Investigation into the nature of metal threads in a Renaissance tapestry and the cleaning of tarnished silver by UV/Ozone treatment; *Journal of Material Science*, **Vol.** 38 (2003);: pp. 3307-3314. ISSN: 0022-2461
- [5] Rezić, I.; Characterization of metal fibers of special purposes, Dissertation, University of Zagreb, Croatia, 2009
- [6] Rezić, I., Steffan, I.; ICP-OES determination of metals present in textile materials; *Microchemical Journal*, **Vol.** 85 (2007);: pp. 46-51. ISSN 0026-265X
- [7] Paliinw, R., Sommariva, G., Verità, M.; WDXRF, EPMA and SEM/EDX Quantitative Chemical Analysis of Small Glass Samples; *Microchimica Acta*, **Vol.** 155 (2006);: pp. 132-140.
- [8] Einhäuser, T.J.; ICP-OES and SEM-EDX Analysis of Dust and Powder Produced by the Laser-Processing of a Cr-Ni-Steel Alloy; *Microchimica Acta* **Vol.** 127 (1997);: pp. 265-268. ISSN: 0026-3672 (print) 1436-5073 (web)
- [9] Laigo, J., Christien, F., Le Gall, R., Tancret, F., Furtado, J.; SEM, EDS, EPMA-WDS and EBSD characterization of carbides in HP type heat resistant alloys; *Materials Characterization*, **Vol.** 59 (2008);: pp. 1580-1586. ISSN: 1044-5803
- [10] Anderson, J.C., Leaver, K.D., Rawlings, R.D. and Alexander, J.M.; *Materials Science*, 4th Edition, Chapman and Hall, London, New York, 1990
- [11] Callister, W.D.; *Materials Science and Engineering, An Introduction*; 6th Edition, John Wiley & Sons, USA, 2003
- [12] Askeland, D.R. and Phulé P.P., *The Science and Engineering of Materials*, 4th Edition, Thomson Brooks/Cole, Australia, USA, 2003
- [13] Chiba, A., Sakakura, S., Kobayashi, K.; Dissolution amounts of nickel, chromium and iron from SUS 304, 316 and 444 stainless steels in sodium chloride solutions; *Journal of Materials Science*, **Vol.** 32 (1997);: pp. 1995-2000. ISSN: 0957-4522 (Print) 1573-482X (Online)
- [14] Rezić, I., Steffan, I.; ICP-OES Monitoring of aluminum, copper, cobalt, iron and manganese during bleaching; *American Association Textile Chemists and Colorists Review*, **Vol.** 83 (2008);: pp. 44-48. ISSN, 1532-8813
- [15] Rezić, I., Zeiner, M., Steffan, I.; Determination of 28 selected elements in textiles by axially viewed inductively coupled plasma optical emission spectrometry; *Talanta*, **Vol.** 83 (2011);: pp. 865-871. ISSN 0039-9140
- [16] Zeiner, M., Rezić, I., Steffan, I.; Analytical Methods for the Determination of Heavy Metals in Textile Industry; *Kemija u Industriji*, **Vol.** 56 (2007);: pp. 587-595. ISSN 1334-9090

- [17] Bokić, Lj., Rezić, I., Flinčec, S.; Determination of Alkaline and Earth Alkaline Elements in Natural Cellulose Textile Materials by Atom Absorption Spectrometry; *Tekstil*, **Vol.** 52 (2003);: pp. 503-511. ISSN 2147-0510
- [18] Rezić, I., Čurković, L., Ujević, M.; Simple methods for characterization of metals in historical textile threads; *Talanta*, **Vol.** 82 (2010);: pp. 237-244. ISSN 0039-9140
- [19] Rezić I., Bokić Lj., Horvat A.J.M.; TLC Separation and identification of heavy metals present in cotton material; *Journal of Planar Chromatography Modern TLC*, **Vol.** 17 (2004);: pp. 305-308. ISSN 0933-4173
- [20] Rezić, I., Krstić, D., Bokić, Lj.; Ultrasonic extraction of resins from an historical textile; *Ultrasonic Sonochemistry*, **Vol.** 15 (2008);: pp. 21-24. ISSN: 1350-4177
- [21] Rezić, I., Krstić, D., Bokić, Lj.; Analysis of Waxes on Historical Samples by Thin-Layer Chromatography; *Journal of Planar Chromatography Modern TLC*, **Vol.** 22 (2009);: pp. 171-173. ISSN 0933-4173
- [22] Rezić, I., Krstić, D., Bokić, Lj.; A note on the determination of the binder composition on a historical painted textile; *Studies in Conservation*, **Vol.** 51 (2006);: pp. 1-6. ISSN 0039-3630
- [23] Rezić, I., Rezić, T., Bokić, Lj.; Optimization of the TLC separation of seven amino acids; *Journal of Planar Chromatography Modern TLC*, **Vol.** 20 (2007);: pp. 173-177. ISSN 0933-4173
- [24] Seabra AB, and Durán N Nanotoxicology of Metal Oxide Nanoparticles *Metals*, (2015) pp. 5934-975 ISSN 2075-4710
- [25] Rezić, I., Krstić, D., Bokić, Lj.; Novel analytical methods in textile restoration and conservation; *Tekstil*, **Vol.** 58 (2009);: pp. 31-38. ISSN 2147-0510
- [26] Rezić, I., Bokić, Lj., Soljačić, I.; Metal items and metal fibers on historical and present-day textile objects; *Tekstil*, **Vol.** 58 (2009);: pp. 93-104. ISSN 2147-0510
- [27] Rezić, I., Rolich, T.; Quantitative Evaluation of Chromatograms from Scanned Thin-Layer Chromatography Plates; *Tekstil*, **Vol.** 60 (2011);: pp. 74-80. ISSN 2147-0510
- [28] Rezić, I.; Optimization of ultrasonic extraction of 23 elements from cotton; *Ultrasonic Sonochemistry*, **Vol.** 16 (2009): pp. 63 - 69. ISSN: 1350-4177
- [29] <http://www.fabricsolutions.com/cleancool-antimicrobial-fabric/>

Authors:

Ass. Prof. Iva REZIĆ, PhD PhD (corresponding author)
University of Zagreb Faculty of Textile Technology
Prilaz baruna Filipovića 28a, 10 000 Zagreb, Croatia
Phone: + 00385 1 3712 593

Fax: + 00385 1 3712 599

E-mail: iva.rezic@tff.hr

Mag. oecoiog. Lela MARTINAGA
University of Zagreb Faculty of Textile Technology
Prilaz baruna Filipovića 28a, 10 000 Zagreb, Croatia
Phone: + 00385 1 3712 593

Fax: + 00385 1 3712 599

E-mail: iva.rezic@tff.hr

Mislav MAJDAK
University of Zagreb Faculty of Textile Technology
Prilaz baruna Filipovića 28a, 10 000 Zagreb, Croatia
Phone: + 00385 1 3712 593

Fax: + 00385 1 3712 599

E-mail: iva.rezic@tff.hr

Ass. Prof. Maja SOMOGYI ŠKOC, PhD
University of Zagreb Faculty of Textile Technology
Prilaz baruna Filipovića 28a, 10 000 Zagreb, Croatia
Phone: + 00385 1 3712 552

Fax: + 00385 1 3712 599

E-mail: maja.somogyi@tff.hr

PREDICTION OF BOUNDARY ELONGATION FORCE OF FABRIC IN ELASTIC AREA BY LETHERSICH'S RHEOLOGICAL MODEL

Željko PENAVAL; Diana ŠIMIĆ PENAVAL & Maja BANIČEK

Abstract: Under conditions of use, form and properties of fabrics are constantly changing. Tensile forces cause the appearance of viscoelastic or plastic deformations. Such deformations are undesirable because they reduce the quality of the fabric. During fabric use, deformations should be within the elastic range. In order to avoid plastic deformation in fabric, it should be known in advance at what tensile load such deformations will occur. Depending on the mechanical properties of the fabric, an appropriate rheological model should be fitted that describes well their behavior in action of tensile load. For the purpose of testing the rheological properties of fabrics, raw cotton fabrics in sateen weave were weaved with the same warp density and different weft densities. Based on the experimental results obtained for elongation fabric samples, a rheological model according to Lethersich was set up that describes well the process of elongation cotton fabric and can be used to predict the boundary loads of cotton fabrics after which irreversible deformations occur. Appropriate differential equations for tested fabric samples were solved, resulting in dependence between tensile force and elongation.

Keywords: rheology, Lethersich's model, differential equations of elongation, sateen weave, boundary elongation force

1. Introduction

The mechanical properties of woven fabrics are basic parameters for designing and adjusting parameters in the textile industry. Under conditions of use, the form and properties of fabrics are constantly changing. Tensile forces cause the tearing of woven fabric or the appearance of viscoelastic or plastic deformations. Such deformations are undesirable because they cause poor quality of the fabric. Therefore, during the use of the fabric, such conditions should be ensured that the deformation will be within the elastic area. In order to avoid plastic deformation in fabric, it should be known in advance at what tensile load such deformations will occur. An appropriate rheological model that describes well the fabric behavior should be fitted [1]. Rheology is a special branch of continuum mechanics that investigates the occurrence, development, and physics of material deformation as a function of time. It is a science that establishes a connection between forces, that is, stresses and their derivations over time, with the deformations resulting from the action of these forces and their derivations over time [2, 3]. The deformation of the material under the action of finite forces increases continuously. The aim of this paper is to set an appropriate rheological model that describes well the behavior of the cotton woven fabric in the sateen weave under tensile load. With the help of the set model, the allowed values of the tensile force of fabrics can be predicted, which should be within the limits of elastic deformation. By experimental testing of elongation woven fabric samples, the functional relationship between force and deformation (strain) in the form of a characteristic elongation diagram (F - ϵ) for the woven fabric is obtained, Figure 1a.

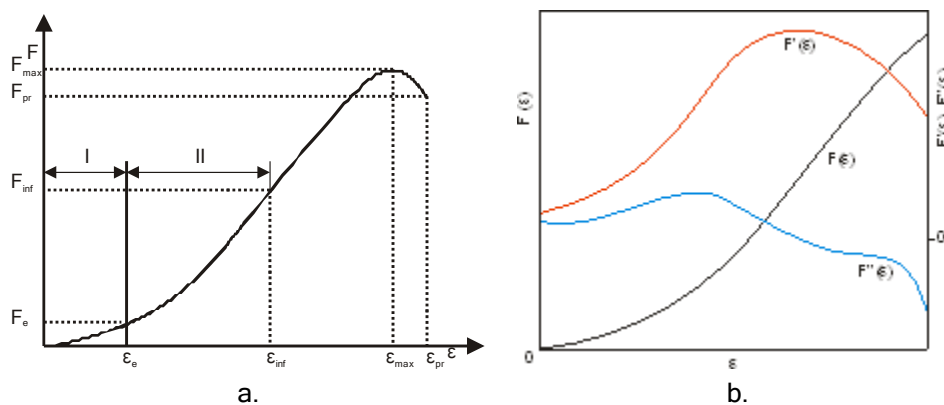

Figure 1: Dependency diagram force-elongation: a) the characteristic diagram of force - elongation (F - ϵ) of the woven fabric, b) the function $F(\epsilon)$, the first $F'(\epsilon)$ and the second $F''(\epsilon)$ derivation of the function

The characteristic points in Figure 1a are: F_{max} - maximum force, F_{pr} - breaking force immediately before the interruption of fabric sample, F_{inf} - force at the inflection point, F_e - force at the limit of elasticity, ϵ_{max} - maximum elongation of the fabric sample at maximum force, ϵ_{pr} - elongation of the fabric sample to break, ϵ_{inf} - elongation at the inflection point, ϵ_e - elastic elongation, W_{max} - work below the curve to maximum force, W_{pr} - work below the curve to the breaking force, W_{inf} - work below the curve to the force at the inflection point. Area I is up to elasticity limit and is called the elastic region. Area II is from the elasticity limit (F_e, ϵ_e) to the inflection point (F_{inf}, ϵ_{inf}) and is a viscoelastic region.

The elasticity limits of woven fabrics are determined on the basis of the force-elongation diagram $F(\epsilon)$ and on the basis of $F'(\epsilon)$ and $F''(\epsilon)$. Figure 1b represents the force-elongation function as well as its first derivation and second derivation. The maximum of the first derivative $(F'(\epsilon))_{max}$ shows the elongation value ϵ_{inf} and the associated permissible load F_{inf} , i.e. the inflection point on the $F - \epsilon$ curve. The inflection point is shown with the associated coordinates $(F_{inf}, \epsilon_{inf})$ and up to that point the fabric shows elastic and viscoelastic properties. When the function of the first derivation reaches its maximum, at that point the second derivation equals 0, i.e. $F''(\epsilon)=0$.

2. Rheological models

The rheological behavior of the material is shown by the rheological equation of state of the material showing the relation of stress, deformation and their derivation by time, Eq. (1):

$$f(\sigma_{ij}, \dot{\sigma}_{ij}, \epsilon_{kl}, \dot{\epsilon}_{kl}) = 0 \quad (1)$$

Stresses and deformations are called rheological variables, and scalar values that characterize the rheological properties of materials are called rheological constants. The basic rheological models are Hooke's „H“, Newton's „N“, St. Venant's „St.V“ model. Real bodies have at the same time properties of elasticity, viscosity and plasticity in different form and relationship. By combining simple elements, a body model can be formed to describe the behavior of real materials [1].

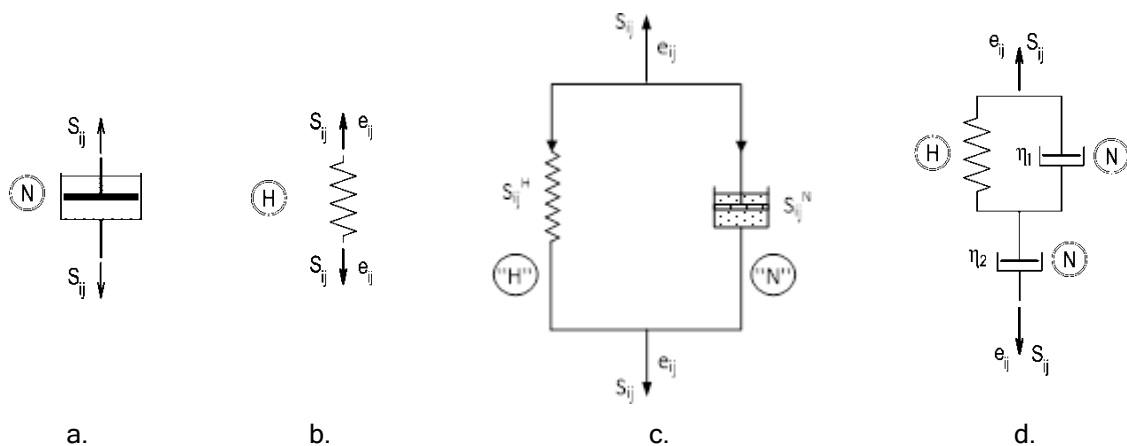

Figure 2: Rheological models: a) Newton's model, b) Hooke's model, c) Kelvin's model, d) Lethersich's model

Newton's model, Figure 2a, is a viscous silencer and represents a model of a viscous fluid. For a uniaxial stress state is $\sigma = \eta \dot{\epsilon}$, where are: η is Newton's coefficient of viscosity, $\dot{\epsilon}_{ij}$ is the strain rate. *Hooke's model*, Figure 2b, describes a linear elastic body. The linear relationship between the stress deviator S_{ij} and the strain deviator e_{ij} is shown by the relation $S_{ij}=2Ee_{ij}$. *Kelvin's model* is formed by the parallel connecting of Hooke's and Newton's material, Figure 2c. It is a viscoelastic material that slowly reaches the final deformation, retains it for a long time without further noticeable increase. For uniaxial stress states, the expression is: $\sigma = E\epsilon + \eta\dot{\epsilon}$. *Lethersich's model* is suitable for testing the rheological properties of cotton yarns, cotton woven fabrics of different types of weaves and densities subjected to tensile load, Figure 2d. This material is represented by the model as a serial connection between Kelvin's and Newton's elements, so its rheological formula is $L = K - N$. The expression for the rate of deformation of the body according to the Lethersich model can be written in the following form:

$$\dot{\varepsilon} = \frac{\sigma}{\eta_N} + \frac{\sigma}{\eta_K} - \frac{\sigma}{\eta_K} \cdot \exp\left(-\frac{\sigma}{\eta_K} \cdot t\right) \cdot \left[\varepsilon_0 + \frac{1}{E_K} \int \sigma \cdot \exp\left(\frac{\sigma}{\eta_K} \cdot t\right) dt\right] \quad (2)$$

where are: η_N viscosity coefficient of Newton model, η_K viscosity coefficient of Kelvin model, E_K coefficient of elasticity of Kelvin model, ε_0 initial elongation. By derivation by time and arranging Eq. (2), the differential equation of the rheological model of cotton woven fabric is obtained in the form:

$$\dot{\varepsilon} \cdot \eta_K + \varepsilon \cdot E_K \cdot \eta_K = \sigma \cdot (\eta_N + \eta_K) + \sigma \cdot E_K \quad (3)$$

Because it is $\dot{\varepsilon} = konst.$ and $\varepsilon=0$, the Eq. (3) takes the following form:

$$\sigma \cdot (\eta_N + \eta_K) + \sigma \cdot E_K = \dot{\varepsilon} \cdot E_K \cdot \eta_K \quad (4)$$

The solution of differential Eq. (4) after determining the integration constant C from the initial conditions, for $t = 0$, $\sigma = 0$, can be represented by Eq. (5) which represents the time dependence of the stress.

$$\sigma = \eta_N \cdot \dot{\varepsilon} \cdot \left[1 - \exp\left(-\frac{100 \cdot v \cdot \tau_r}{l_0} \cdot \varepsilon\right)\right] \quad (5)$$

where is: $\tau_r = (\eta_N + \eta_K) / E_K$ - relaxation time, l_0 - initial sample length, v - test speed, ε - elongation.

3. Experimental testing

In the experimental part of the paper, tests were carried out on elongation cotton woven fabric samples in sateen weave with the same warp density and different weft densities. Tensile properties of all specimens were tested according with standard ISO 13934-1:2008 using the strip method for measuring fabric strength and its elongation on a tensile strength tester Textechno Statimat M. In this way, force- elongation (F- ε) curves were obtained. The samples were cut in warp direction and weft direction. The direction of action of the tensile force during the test is always the same. Five tests were done for each mentioned cutting direction of the sample. Samples with standard dimensions 350 x 50 mm were cut and clamped in clamps of the tensile tester at a distance of $l_0=200$ mm and subjected to uniaxial tensile load. The pulling speed of clamps is $v=100$ mm/min, and it can be stated that deformation rate is constant. Sample break time is 20 s.

Table 1: Test results for basic fabric parameters

Fabric structure	Fabric tag	Warp direction			Weft direction			Weight (g/m ²)	Thickness, t (mm)
		Yarn fibres	Yarn count (tex)	Density (cm ⁻¹)	Yarn fibres	Yarn count (tex)	Density (cm ⁻¹)		
Sateen	A12	Cotton	30.3	23.9	Cotton	30.3	11.9	115.63	0.361
	A18	Cotton	30.3	23.9	Cotton	30.3	18.1	134.13	0.362
	A24	Cotton	30.3	24.0	Cotton	30.3	24.0	155.19	0.363

Raw cotton fabrics were weaved for the purpose of testing the rheological properties of the woven fabrics. Fabrics samples of the stated structural characteristics were made on an OMNIplus 800 tt air-jet loom Picanol. In Table 1 are the actual (measured) values of structural parameters of the raw woven fabrics. Yarn linear density was determined by the gravimetric method according to standard ISO 2060:1994. Number of threads per unit length was determined according to standard ISO 7211-2:1984. Standard ISO 5084:1996 describes a method for the determination of the thickness of fabric. The same yarn was used for the weft and the warp. Determination of the density of warp and weft threads was carried out using computer-controlled (stereo) microscope DinoLite.

3.1 Overview of test results

The first letter in the fabric label indicates the type of weave, the second letter indicates the direction of force action, and the number indicates the weft density, eg. AP18 - sateen weave, the force in the weft direction, the weft density 18.1 cm⁻¹. A diagram of the mean values of the test results obtained for the action of tensile force F and the belonging elongation ε when the fabric samples are cut in the warp and weft direction for all weft densities are shown in Figure 3 a. When samples are cut in the weft direction, the values of F_{max} and the belonging elongation ε_{max} increase significantly with the density of the weft. When the samples are cut in the warp direction, the F_{max} values change slightly, while the corresponding elongation ε_{max} increase with increasing weft density. The first derivation of the function F(ε) is shown in Fig. 3b and the second derivation

of the function $F''(\epsilon)$ in Fig. 3c. The first derivative maxima $(F')_{\max}$ decrease and the corresponding elongation (ϵ_{inf}) increases with the increase in weft density when the samples are cut in the warp direction. When samples are cut in the weft direction, with the increase in weft density, the maxima of the first derivation $(F')_{\max}$ and the belonging stretching (ϵ_{inf}) increase. Figure 3d shows the values of the forces and the associated elongations at the inflection points. The values $(F_{\text{inf}}, \epsilon_{\text{inf}})$ obtained by the model, when the force acts in the warp direction and in the weft direction, can be represented by lines.

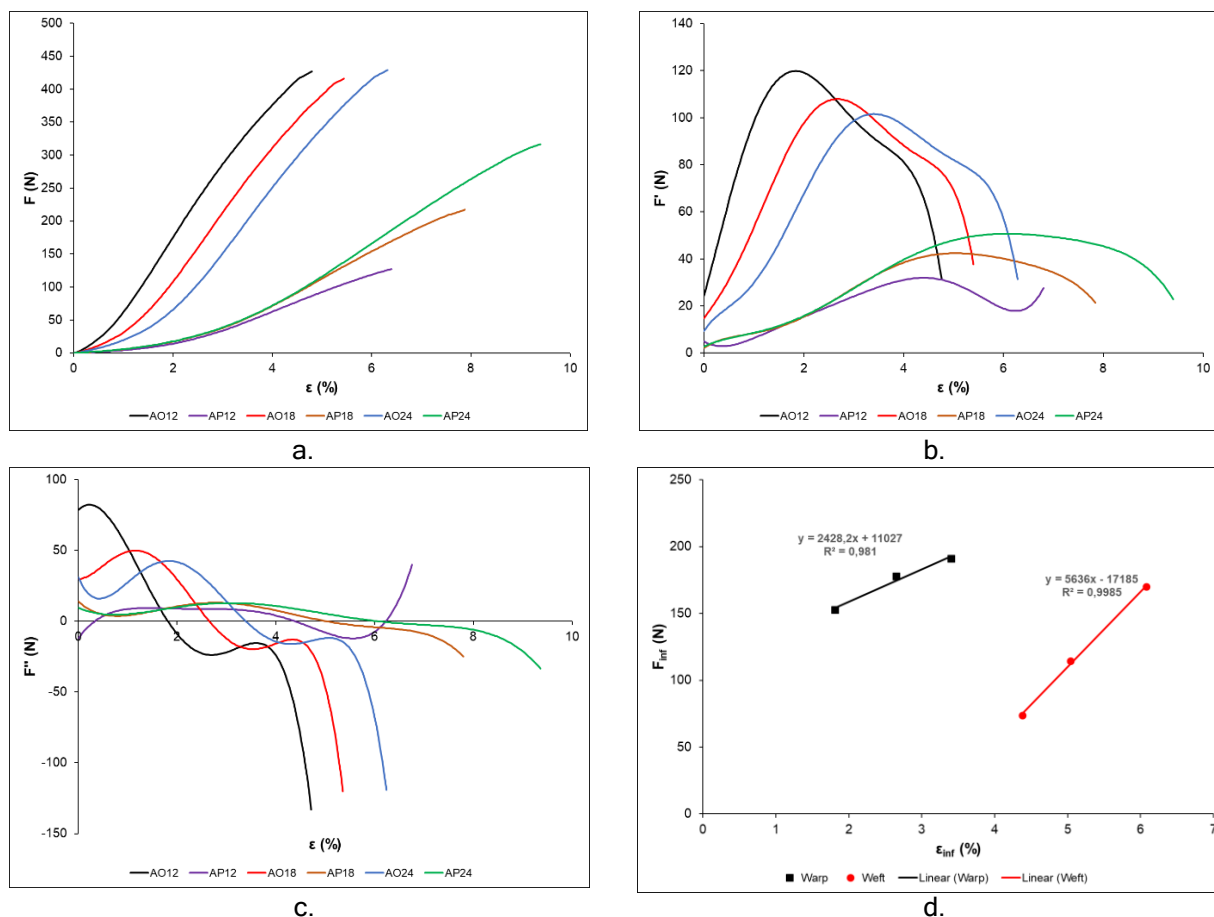

Figure 3: Diagrams for samples with different weft densities: a) force - elongation ($F-\epsilon$), b) the first derivation of a function $F'(\epsilon)$, c) the second derivation of function $F''(\epsilon)$, d) force F_{inf} - elongation ϵ_{inf} at the inflection point

Experimental values $(F_{\text{inf}}, \epsilon_{\text{inf}})$ approximately can be connected with the line, and very high coefficients of correlation R^2 are obtained for both the warp direction and the weft direction. When samples are cut in the weft direction, values F_{inf} increase faster than for the warp direction. So, for the weft direction, the slope of the line is much higher than for the warp direction.

Table 2: Mean values of F_{\max} , ϵ_{\max} , W_{\max} , F_{inf} , ϵ_{inf} , W_{inf}

Fabric tag	F_{\max} (N)	ϵ_{\max} (%)	W_{\max} (Ncm)	F_{inf} (N)	ϵ_{inf} (%)	W_{inf} (Ncm)
AO12	426.9	4.80	206.2	151.8	1.80	21.8
AP12	127.0	6.40	62.8	73.5	4.36	16.3
AO18	416.2	5.44	206.4	174.4	2.64	33.7
AP18	217.1	7.88	134.6	112.6	5.00	40.8
AO24	428.9	6.32	233.0	187.1	3.36	41.3
AP24	317.3	9.44	236.5	168.0	6.04	65.8

The mean values of the test results of maximum force F_{\max} , maximum elongation ϵ_{\max} , work to maximum force W_{\max} , force at the inflection point F_{inf} , elongation at the inflection point ϵ_{inf} and work up to the inflection point W_{inf} are shown in Table 2.

4. A rheological model of fabric according to Lethersich to the inflection point

Predicting the behavior of cotton woven fabrics to the inflection point when a tensile force is acting can be represented by rheological model according to the Lethersich. When extending on a tensile tester, the deformation rate has a constant value. The initial length of the test tube is $l_0=0.2$ m. The pulling speed of the clamps of the tensile tester is $v=100$ mm/min. By introducing these data into Eq. (5) and assuming that the viscosity coefficients are equal ($\eta_N = \eta_K$), Eq. (6) is obtained:

$$\sigma = a \cdot [1 - e^{-b \cdot \varepsilon}] \quad (6)$$

By fitting the experimentally obtained data in the form of Eq. (6), the values of the coefficients "a" and "b" were determined [4].

Table 3: The coefficients of the model to the inflection point

Fabric tag	a	b	Determination coefficient R ²	Root Mean Square Error RMSE (N)
AO12	-5355.1	-0.76077	0.99728	2.436
AP12	-626.2	-0.60983	0.99852	0.968
AO18	-3450.0	-0.69532	0.99700	2.910
AP18	-1304.4	-0.45798	0.99694	1.976
AO24	-2359.8	-0.66461	0.99775	2.596
AP24	-1798.8	-0.39550	0.99586	3.216

In Table 3 are the values of the coefficients "a" and "b" for models which are obtained on the basis of a rheological model based on experimental data for fabrics obtained by extending woven fabric samples.

4.1 Comparison of results

Diagrams of the mean values of the F- ε results obtained experimentally and according to the Lethersich's model to the inflection point and relative error are shown in Figures 4-6.

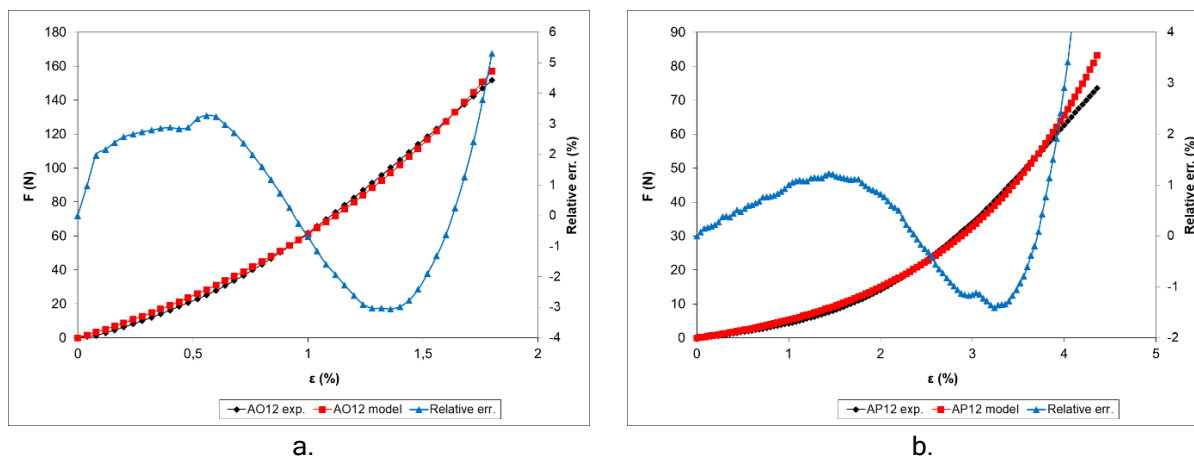
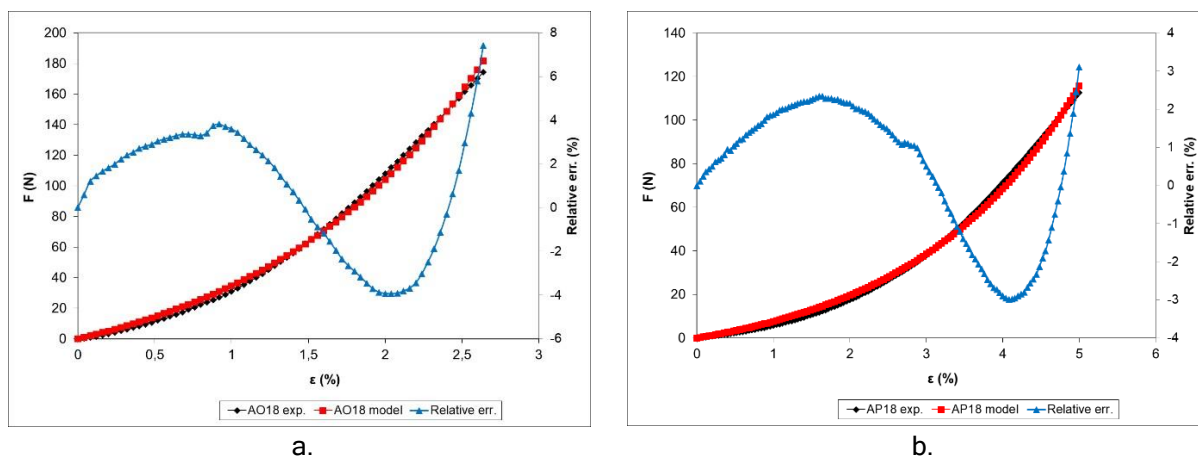

Figure 4: Diagram force-elongation (F- ε) obtained experimentally and by model: a) sample AO12, b) sample AP12



a.

b.

Figure 5: Diagram force-elongation (F- ϵ) obtained experimentally and by model: a) sample AO18, b) sample AP18

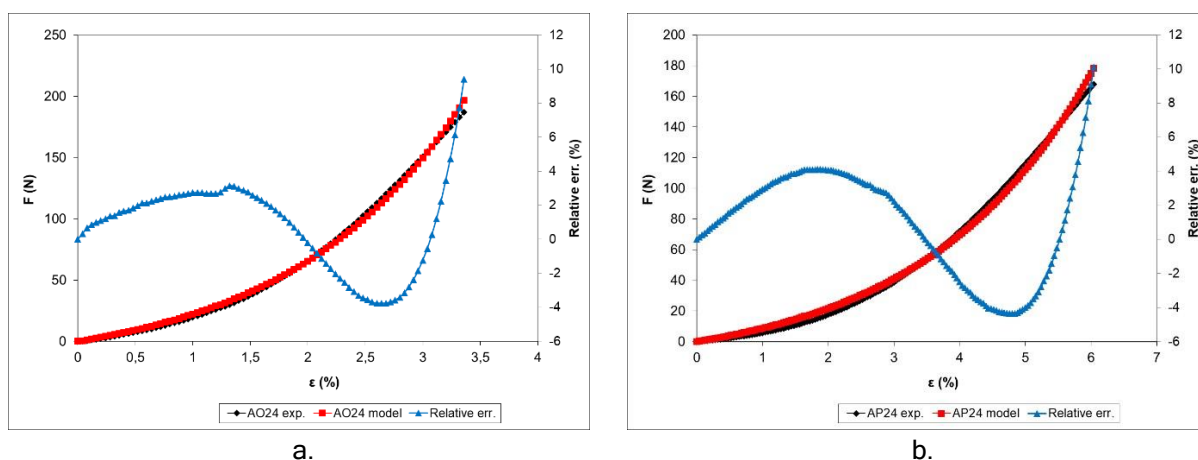

a.

b.

Figure 6: Diagram force-elongation (F- ϵ) obtained experimentally and by model: a) sample AO24, b) sample AP24

The diagrams in Figures 4-6, which are obtained on the basis of experimental data (black) and the results obtained using the model (red) do not have a linear form, which confirms that the woven fabrics do not behave ideally elastic. For fabrics, viscoelastic behavior in the analyzed area is observed. After the elastic limit, a higher rate of material deformation occurs and the fabric structure is disrupted. Therefore, the inflection point of the fabric represents the boundary load at which the deformations occurring in the fabric will not significantly affect the stability of the structure and the durability of the fabric.

5. Conclusion

The mechanical properties of the fabrics and the boundary load can be predicted using rheological models. Based on experimental results obtained for elongation fabric samples in sateen weave, a rheological model according to Lethersich was set. This model describes the behavior of cotton fabrics subjected to the action of the tensile force in a zone dominated by elastic deformations, ie. up to the inflection point. Appropriate differential equations for tested fabric samples were derived and solved, resulting in dependence between the tensile force and the elongation. The estimation error of the force-elongation curve between the model and the experimentally obtained values is very low and is expressed through the root mean square error (RMSE). The relative error is between -4% and 8%. By analyzing the diagram, it can be concluded that the Lethersich model describes well the process of elongation and the behavior of the cotton fabrics in sateen weave in the zone of elastic deformation and can be used to predict the boundary loads of the cotton fabrics after which irreversible deformations of these materials occur.

References

- [1] Šuklje, L.: *Rheological aspects of soil mechanics*, John Wiley, ISBN 0471835501, London, 1969.
- [2] Postle, R., de Jong, S.: *The Rheology of Woven and Knitted Fabrics, Part 1: Fabric Geometry and Force Methods of Analysis Applied to Fabric Mechanics*, *Sen'i Kikai Gakkaishi (Journal of the Textile Machinery Society of Japan)*, **34** (1981) 5, pp. 264-273, ISSN 0371-0580

- [3] Zhang, X.: Bagging of Woven Fabrics: The Rheological Mechanism and Predictions, *Journal of the Textile Institute*, **92** (2001) 3, pp. 235-255, ISSN 0040-5000
- [4] Tarfaoui, M. et al.: Predicting the Stress-Strain Behavior of Woven Fabrics Using the Finite Element Method, *Textile Research Journal*, **71** (2001) 9, pp. 790-795, ISSN 0040-5175

Authors:

Prof. Željko PENAVAL, Ph.D. (corresponding author)
University of Zagreb, Faculty of Textile Technology, Department of Textile Design and Management
Prilaz baruna Filipovića 28a, HR-10000 Zagreb, Croatia
Phone: +(385) (1) 3712 576 Fax: +(385) (1) 3712 533 E-mail: zeljko.penava@ttf.hr

Prof. Diana ŠIMIĆ PENAVAL, Ph.D.
University of Zagreb, Faculty of Civil Engineering, Department of Engineering Mechanics
Fra Andrije Kačića-Miošića 26, HR-10000 Zagreb, Croatia
Phone: +(385) (1) 4639 426 Fax: +(385) (1) 4828 049 E-mail: dianas@grad.hr

Maja BANIČEK, mag. ing. aedif.
University of Zagreb, Faculty of Civil Engineering, Department of Engineering Mechanics
Fra Andrije Kačića-Miošića 26, HR-10000 Zagreb, Croatia
Phone: +(385) (1) 4639 363 Fax: +(385) (1) 4828 049 E-mail: maja.banicek@grad.unizg.hr

CHARLESTON BEADED DRESS: PRELIMINARY ANALYSIS

Danijela JEMO; Sandra FLINČEC GRGAC; Danijela ERAK & Agneza ŠTAJER

Abstract: *Charleston beaded dress restored in the textile conservation-restoration workshop at the University of Dubrovnik is a very interesting and intriguing object. Preliminary analysis conducted prior to conservation-restoration treatment revealed information necessary for a complete understanding of materials, technical characteristics, and its historical background. Microscopic analysis and FTIR-ATR spectroscopy were used to determine types of fiber, both original and those used in previous repairs. FTIR-ATR technique was also used for the analysis of beads that decorate the dress in a very elaborate way.*

Keywords: *charleston, beaded dress, textile conservation-restoration, FTIR-ATR*

1. Introduction

The 1920s were largely marked by optimism fueled by the end of World War I which led to a much more casual approach to life that was reflected in the music, dance, and fashion of the time [1]. One of the more popular dance styles was Charleston (named after the city of Charleston). The basic steps are quick and easy, with lots of funny figures very suitable for improvisation. Just as "art imitates life", so did women's fashion of that time adjust to the moment. This specifically means that the lines were much simpler, the length of the clothes was shortened, and a very popular "lowered waist" was introduced. Also, dresses no longer followed the shape of the body but the silhouette was somewhat boyish, leading to the female attributes being muted. Finally, both evening and day dresses were sleeveless [2]. Without corsets and other fashion accessories, these dresses did not restrict movement and were often adorned with a multitude of hand-sewn sequins and beads, which was a very time-consuming process that required great craftsmanship. The trend of decorating dresses with beads became so widespread that in one fashion column from 1928, when the trend had been popular for some time, it was called „bead-madness“ [3]. Also popular were floral motifs that were placed around the waist (not the dress, which was lowered, but the waist of a woman's body) and at the bottom of the dress, just above the knee. This fashion persisted until the Great Depression (1929-33) when a return to traditional and more feminine forms was recorded [1,3].

"Clothes don't make a man", but it reveals a lot about a person [4]. Even a simple dress tells a story of a historical period or a specific person. The Charleston dress, which is a subject of this paper, does just that. The current owner, Agneza Štajer, received the dress as a gift from her friend Jasna Berković, who spent some time in London after completing her English studies around the 1970s. Although there is no information about the origin and the original owner of the dress, its history can still be traced from the moment when this very interesting item was brought to Croatia. Based on the testimony of the current owner, the dress caught the eye of her friend when visiting a vintage shop. Jasna was full of life and a confident young person prepared to bravely wear her Charleston dress on special occasions, even at a time when this type of clothing was out of fashion.

Due to its special historical and sentimental value, the dress is currently being restored in the workshop for the conservation-restoration of textiles at the University of Dubrovnik. During the conservation-restoration process, research works and preliminary analyzes were carried out. Preliminary analyzes generally precede conservation-restoration treatment and are carried out with the aim of obtaining as much information as possible about the object. All materials, as well as detected damage, must then be classified and documented, both descriptively and graphically.

Technical-constructive characteristics and apparent conservation conditions were investigated with digital microscope *DinoLite* AM413T (magnification: 10x-60x, 200x). Microscopic analysis of the fibers was performed with an Olympus BX40F4 light microscope and FTIR spectroscopy (FTIR-ATR, PerkinElmer Spectrum 100, USA). The microscope was connected to a computer via an Olympus SC30 camera and the *Stream Start* software program was used. ATR-FTIR of textile samples were traced in four scans at a resolution of 4 cm⁻¹ in a wavelength range from 4000 to 400 cm⁻¹.

2. Condition assessment

The dress is made of light cotton fabric in plain weave and pink color tone. The entire surface of the dress is very richly decorated with two types of hand-sewn beads arranged in geometrical and floral motifs (Figure 1a, b). It is assumed, based on stylistic characteristics that the dress dates back to the mid-1920s [2].



Figure 1: Charleston dress: a. front side, b. detail of decorative beads

The dress is well preserved as all previous owners have conscientiously treated the object and handled it with care.

2.1. Technical-constructive characteristics

Charleston dress is a unique item whose pattern consists of an upper and lower front and upper and lower back pattern pieces (Figure 2). Although very simple, it is very skillfully and expertly executed as indicated by a couple of details: due to the presence of pearls and beads, a hand-sewing technique was employed, rather than machine stitching, and all of the horizontal edges are rounded in a very specific fashion as indicated in Figure 2.

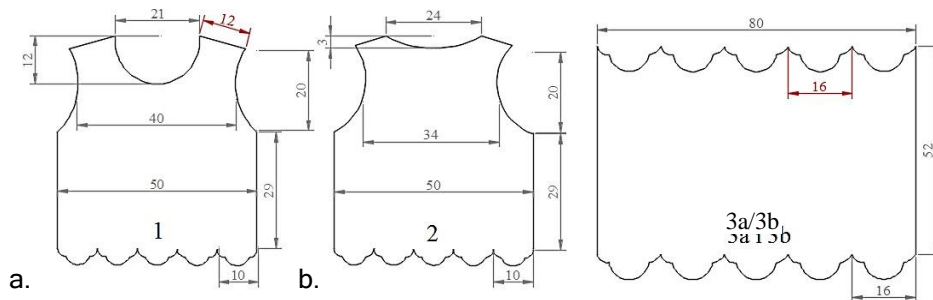

Figure 2: Sewing pattern a. front top, b. back top, c. front and the back of the skirt are identical (3a and 3b)

As straight stitch is not particularly strong, pattern pieces were sewn together using the so-called French seam (where the raw edges on the inside are encased in an extra row of stitching), which gave it greater strength. The making of the dress took place through several phases in a specific order, as shown in figure Figure 3.

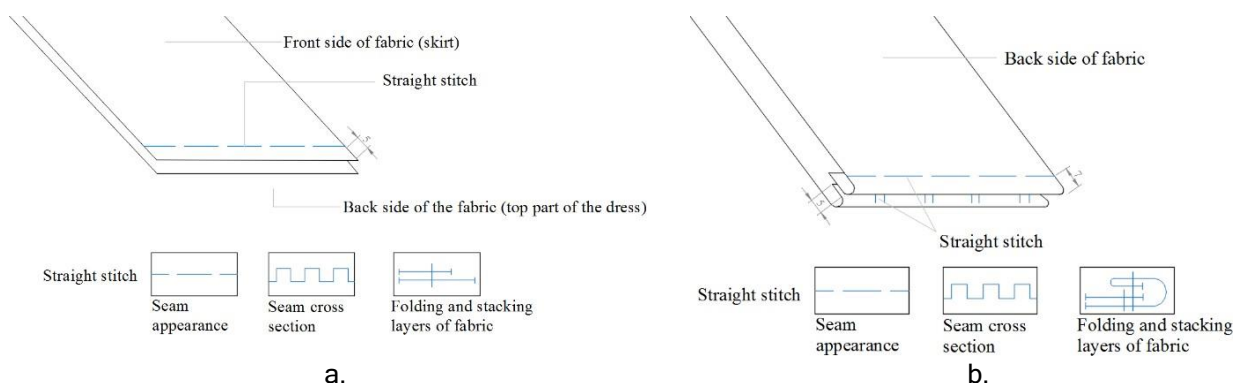

Figure 3: Graphic representation of a straight stitch with which the top and bottom parts of the dress are connected into a whole: a. first stage, b. second stage

Hemming was performed by hand sewing technique. The hems are located around the neckline, alongside cuffs and at the bottom of the skirt, following the decorative bead pattern. They are made by simply folding the embroidered edges of pattern pieces and sewn using a small straight stitch. Fastening of beads in longitudinal, ie free geometric motifs were performed with a chain stitch over the entire surface of the dress.

a. Fiber analysis

Information on materials a historical object is made of primarily serves as a tool for the correct selection of the most appropriate materials and methods to be used in the conservation-restoration process, as well as for determining optimal microclimatic conditions for storage and/or exhibition of objects after conservation-restoration works have been concluded.

All of the samples were taken in very small quantities and from a position on the object that did not disturb its structure or aesthetic appearance. Fibers are characterized primarily by microscopy and compared to reference material. Microscopic analysis of fibers was performed on the samples of warp and weft that basic fabric is made of, on the samples of threads with which the pattern pieces were sewn together and of the threads with which the beads were attached to the dress. All analyzed samples exhibit a flat twisted ribbon-like appearance characteristic for cotton fibers (Fig.3b) [5].



Figure 4: The dress is made of breathable and lightweight cotton fabric (*etamine*): a. Macro photography of the plain weave of the cotton fabric taken with a *Dino lite* digital microscope, b. Longitudinal microscopic image of the warp

The most noticeable type of damage on the object is the loss of white and gray beads, especially on the upper front and back pattern pieces. Apart from the complete separation of the beads from the surface of the object, in some places, there was only a separation of a series of beads at the ends of seams. In these places, the beads were fastened back onto the fabric of the dress as a poorly executed previous repairs.

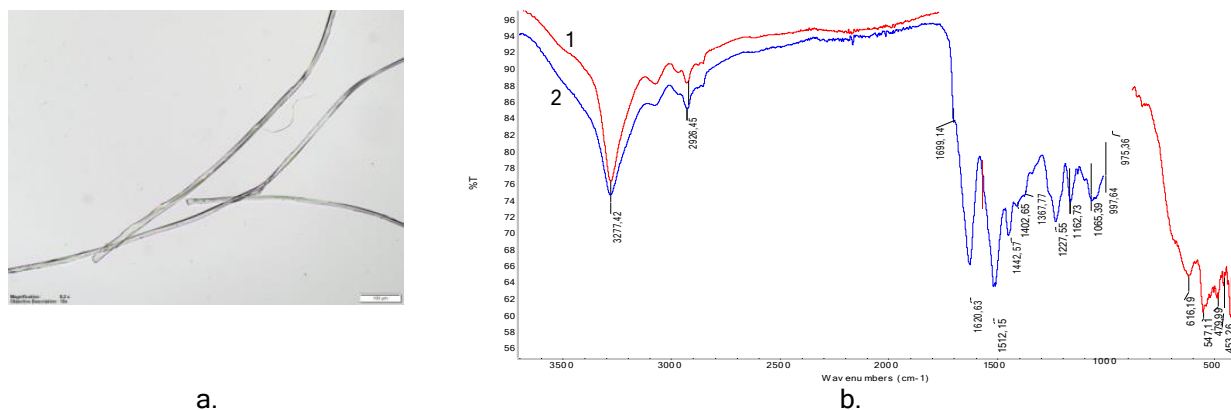

Figure 5: Previous repairs performed with a thread in beige color: a. longitudinal microscopic image of the fiber, b. FTIR comparison: sample of thread used in repair (2) and referent spectra of silk fiber (1)

The microscopic examination of the sample used for previous repairs reveals the structureless and smooth surface of the fibers. FTIR-ATR spectra of the sample from previous repairs compared with the reference silk spectra indicate a high percentage of similarity. In addition, the peaks at 1699 cm^{-1} and 1620 cm^{-1} in the amide I region is characteristic in all spun silks [6].

2.3 Analysis of decorative beads

There are two types of decorative beads which are chain-stitched onto the surface of the cotton fabric the dress is made of. Longitudinal geometric and floral motifs are executed with tubular beads in white color, while those in the free form are tubular beads, but which consist of two parts: the inner part in gray color and the outer part which is transparent (Figure 1b). Floral motifs are located on the front and back lower part of the dress, slightly above the knee (Figure 1a).

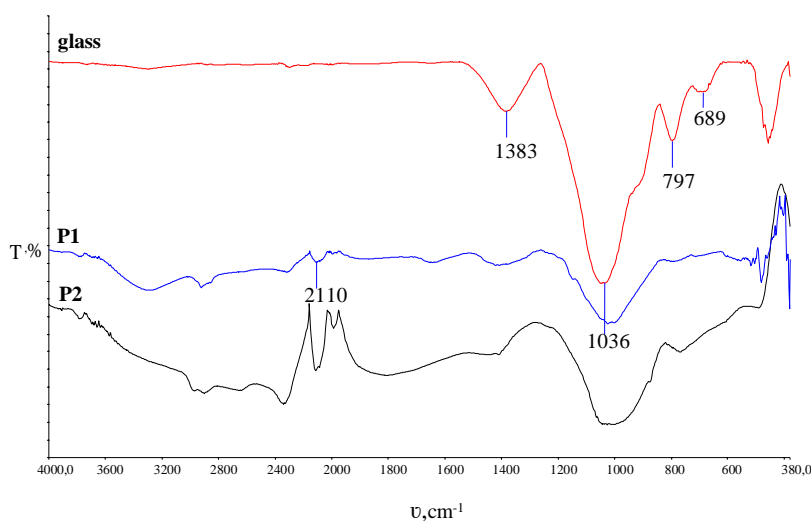

Figure 6: FTIR-ATR spectra of the glass referent spectra

The physicochemical properties of the beads were observed by FTIR in the ATR technique to identify the type of material. It can be seen that both tested samples (P1, P2) have a peak in the range from 1030 cm^{-1} to 950 cm^{-1} , which occurs due to asymmetric stretching within the Si – O – Si bonds in the SiO_4 network. The peak in the wavelength range from 770 to 793 cm^{-1} is attributed to the symmetrical vibration of the stretching of the Si - O - Si bonds. Peaks in the range from 2800 cm^{-1} to 2000 cm^{-1} indicate possible impurities within the glass structure, especially in the P2 sample. From the spectral curves shown in Figure 6 we can conclude that glass beads were used to decorate the charleston dress. In future research, efforts will be made to confirm which impurities are used using various methods (SEM-EDX, ICP, etc.) [7, 8].

3. Conclusion

Before conservation-restoration works, tactile and visual assessment, followed with diagnostic tests and instrumental methods of analysis, were carried out. Based on conducted preliminary analyzes we can conclude that the dress in question was not ready-to-wear, but tailor-made. In support of that speaks the absence of the label of the manufacturer and the fact that seams are placed right next to the decorative motifs, something which would be impossible to execute using a sewing machine.

The use of a very fine silk thread to repair damaged parts of the dress suggests that this intervention was probably done long ago rather than more recently. Although it was made unprofessionally, it helped preserve original beads and prevent their further scattering. Also, beads used for the decorative pattern are made of glass, which is characteristic of charleston dresses of the period.

References

- [1] Galić, A.; Klobučar, A.: *U dobru i zlu - Vjenčana odjeća od 1865. do danas*. MUO, ISBN 9789537641443, Zagreb, (2015)
- [2] Smithsonian: *Fashion: The Definitive History of Costume and Style*, Dorling Kindersley Limited, ISBN 9780756698355, New York, (2012)
- [3] Edwards, L.: *How to Read a Dress. A Guide to Changing Fashion from the 16th to the 20th Century*, Bloomsbury Academic, ISBN-10: 1472533275, UK – USA, (2017)
- [4] Obad Šćitaroci, Mladen ; Bojanić Obad Šćitaroci, Bojana. *Dvorci i perivoji u Slavoniji - Od Zagreba do Iloka*. Šćitaroci d.o.o. Zagreb, 1998., str. 335.
- [5] Houck M M: *Identification of Textile Fibers*, Woodhead Publishing, ISBN 1845695658, England, (2009)
- [6] Boulet-Audet, M.; Vollrath, F.; Holland, C.: Identification and classification of silks using infrared spectroscopy, *Journal of Experimental Biology* 218 (2015), pp. 3138-3149, ISSN 1477-9145
- [7] S. Celik et al: Investigations of archaeological glass bracelets and perfume bottles excavated in ancient ainos (enez) by multiple analytical techniques, *Journal of Applied Spectroscopy*, 85 (2018) 1, pp.178-183, DOI 10.1007/s10812-018-0629-1
- [8] Derrick, M.R.; Stulik, D; Landry, J.M.: *Infrared Spectroscopy in Conservation Science. Scientific Tools for Conservation*, ISBN 0-89236-469-6, Los Angeles, (1999)

Authors:

Danijela JEMO, PhD, Assistant Professor (corresponding author)
University of Dubrovnik, Department of Art and Restoration
Branitelja Dubrovnika 41, 20 000, Dubrovnik
Phone: +(385)(20)446032

E-mail: djemo@unidu.hr

Sandra FLINČEC GRGAC, Associate Professor
University of Zagreb Faculty of Textile Technology
Prilaz baruna Filipovića 28a, 10 000 Zagreb, Croatia
Phone: +(385) (01) 4877355

E-mail: sflincec@ttf.hr

Danijela ERAK, mag. art., professional associate at the University of Dubrovnik
University of Dubrovnik, Department of Art and Restoration
Branitelja Dubrovnika 41, 20 000, Dubrovnik
Phone: +(385)(91)1388011

E-mail: erak.danijela@gmail.com

Agneza ŠTAJER, student
University of Dubrovnik, Department of Art and Restoration
Branitelja Dubrovnika 41, 20 000, Dubrovnik
Phone: +(385)(01)2791595

E-mail: agneza.stajer@unidu.hr

DESIGN AND COMPUTER PATTERN MAKING OF A COLLECTION OF INDIVIDUALIZED MEDICAL UNIFORMS

Katarina ZMEŠKAL & Slavenka PETRAK

Abstract: *The subject of research is the issue of clothing size systems defined by different marking systems and linear grading, where the patterns are not sufficiently adapted to different body shapes. The shortcomings of the existing medical uniforms are examined as well as the requirements of individuals, based on a survey among respondents in the health area, in order to obtain guidelines for the design and computer pattern making of functional medical uniforms to adapt to their needs and function with a goal to facilitate their work. Based on all the established results, the design of the new uniforms is designed for different shapes and types of female and male body, with the aim of achieving the best fit of the model in aesthetic and functional sense. The basic patterns necessary for modeling of female and male uniforms were made in the CAD system for computer pattern making and design of clothes. The complete design of computer 3D prototypes of uniforms was performed for different types of male and female body. Also, the results of research present patients evaluation of existing uniforms considering the colors of the uniforms and the appearance of the staff.*

Keywords: *medical uniform, body shape, functionality, computer clothing design*

1. Introduction

The term "uniforms" means clothing in a specific color, a specific cut, and specific clothing and features for the function of a person, such as medical personnel, police, fire department, etc. Uniforms are standardized forms that automatically connect to specific person, or function [1]. This correlation of uniform and function associates teamwork and instilling confidence. For example, a medical uniforms, white as a display of cleanliness and sterilized working conditions in hospitals. At the same time, the uniform is also a protection for the person wearing it. In accordance with the profession for which the uniform is intended, the characteristics of the uniform, materials and cut are adapted [2,3]. Uniforms must fulfil some basic criteria such as comfort, functionality, appropriate sizes and cut. In the area of manufacturing uniforms for medical staff, there is a problem of inadequate models in terms of design, size and suitability of uniforms for different body shapes, and therefore the functionality of the model. Due to the existence of different marking systems for clothing sizes, uncertainties are present if the garments are on the international market. Except for the marking system, the problem arises in the linear grading of garments. Differences in body shapes are then most pronounced, just as inappropriate cut of clothing in relation to body shape [4-6].

In a 2006 survey, Singh concluded that people make their first impression within the first 90 seconds, with 62-90% of the estimate being based on color and registered by the brain before text or headline [7]. Therefore, it is necessary to consider the basic meaning of colors, their relation to different disciplines, and the influence of particular colors on the physiology and psychology of human. Because of the "traditional" colors of uniforms (green and blue), it is common to confuse patients with non-traditional colors and associate staff with other professions. Based on the first impression, the patient "receives information" about whether the staff is qualified, whether he or she deserves his / her confidence, and whether the patient is willing to allow the staff to make physical contact. According to a study by The Ohio State University, patients rated green as typical for nurses / technicians (46.7%), while doctors associated with dark blue (22.5%), which is surprising, because in real life, doctors are in operating rooms in green uniforms, while nurses / technicians wear blue uniforms. Dark blue was also associated with dentists (9.6%). Pink (30.7%) and purple (27.4%) also associated them with nurses. The color that most associated the subjects with the physicians was light blue with 44.8% of the subjects [7].

Therefore, for the purposes of this research, a survey was conducted among users of medical uniforms in the Republic of Croatia in order to determine the actual needs of users. After conducting the survey and processing the results, the starting point for the design of the uniforms are different shapes of the human body, that is the division of male and female body into types with respect to the relationships of certain measures on the body (breast circumference, lower breast circumference, waist circumference, abdominal circumference, circumference above the hips and the circumference of the hips). The proposal for new uniforms follows the differences in structure and achieves a balance between individual body parts.

2. Method used

For the purpose of the survey, a questionnaire was conducted as the basis for a new design of uniforms for members of both sexes. With the aim of creating a design that suits all body types, studies by P. Robinet from the Université du Québec á Montréal of Canada and Cindy Istook and Janice Wang in the United States have also been analysed [8]. Figure 1 shows the sequence of research and design of the uniforms and simulations.

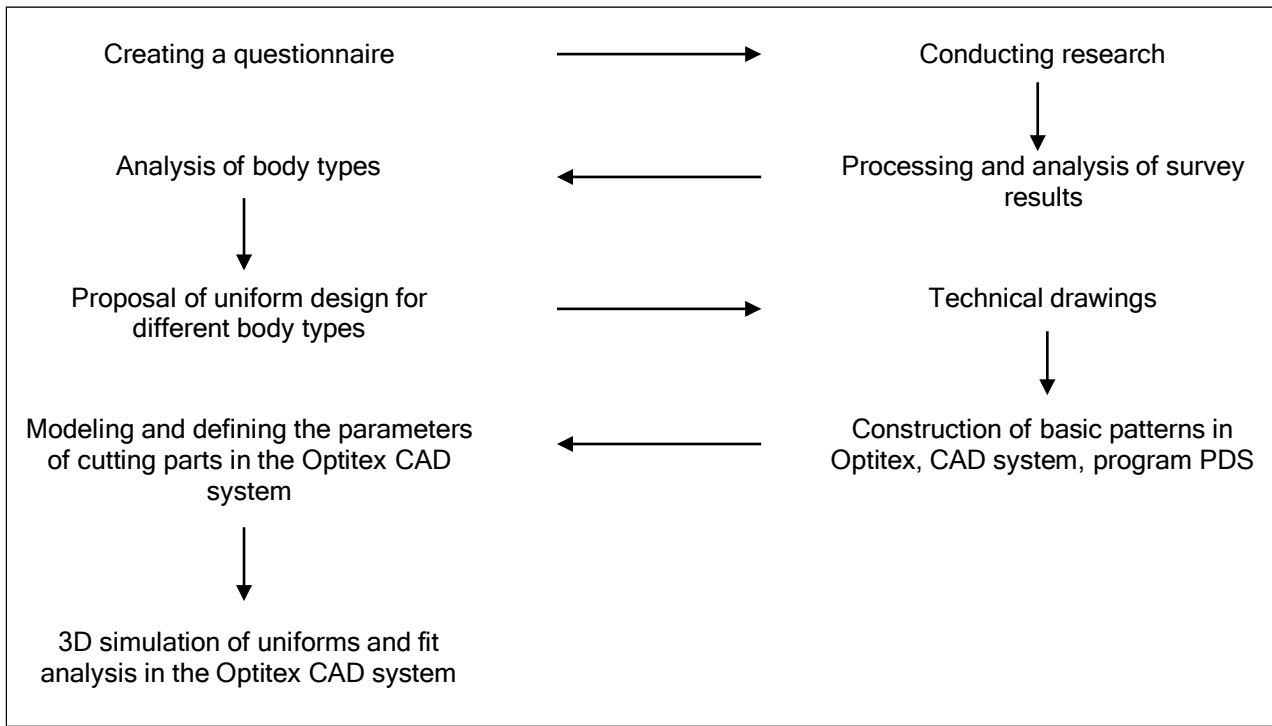

Figure 1: The sequence of research and design of the uniforms

2.1. Questionnaire

The questionnaire is designed to gather relevant information on the shortcomings and needs that uniforms need to satisfy from healthcare users themselves [9]. The survey was conducted on 201 respondents aged 15 to 67 years of both sexes. Respondents are students in the fields of medicine, health and dentistry, and persons employed in health care in 13 cities in the Republic of Croatia. The survey examines the current satisfaction of the uniforms users and their requirements. The questionnaire contains seven units for women and six units for men:

1. in general (gender, age, clothing size, institution, city and job / education level),
2. specification of new uniforms (preferred uniform form, maternity uniforms, textile material, logo),
3. specification of mantle characteristics (color, length, cut, button up, collar, pockets)
4. specification of blouse characteristics (for women) / shirts (for men) (color, length, cut, button, collar, pockets),
5. specification of trousers characteristics (color, length, cut, pockets),
6. specification of skirt characteristics (for women) (color, length, cut, pockets) and
7. specification of the characteristics of the tunic (color, length, cut, button up, collar, pockets).

2.2. Women and men body types

According to a study by P. Robinet conducted on 12.000 women in the USA between 18 and 66 years and according to a study by Cindy Istook and J. Wang on 6318 women, women body types are divided by shapes "reverse triangle" (emphasized shoulders and breasts), "rectangle" (breasts, waist and hips are equal extent), "oval" (fat builds up mostly in the waist area), "triangle" (hips emphasized) and "hourglass" (chest and hips proportions are almost equal), Figure 2 [8].

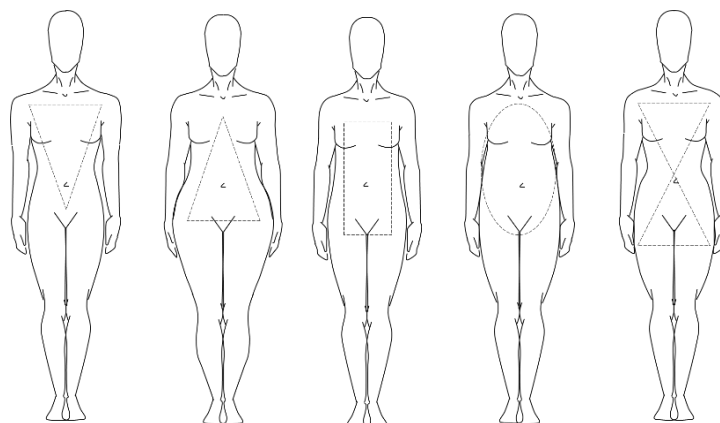

Figure 2: Different women body types based on the study [4]

According to a study by Cindy Istook and Janice Wang in the United States, the male body is defined by the categories "H" (normal weight, lean appearance), "V" (athletic body), "X" (emphasized shoulders and hips) and "O" body (emphasized waist), figure 3 [3].

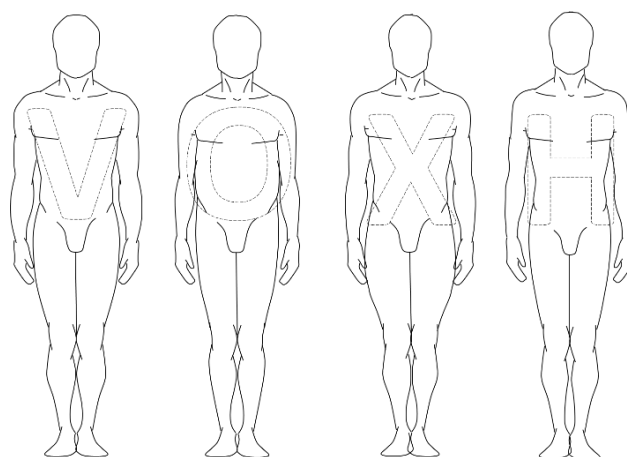

Figure 3: Different men body types based on study [10]

2.3. Medical uniform design proposal

With the achievement of proper functionality, the goal of designing and computer-designing uniforms for medical staff is to design uniforms that will be appropriate and tailored to a specific body type. From the design point of view, the intention is to design models that will allow visual correction of the body by striking a balance in the design itself with regard to body shape. In view of this, the elements of the garments are targeted on the uniform according to the body type.

2.4 Computer development of medical uniforms prototype

The first step is to make a basic pattern of the garment. In the process of technical or structural preparation of a pattern, textile material (fabric, knitwear, interlining, lining, etc.) is also taken into account, which also affects the basic pattern. Basic patterns are constructed according to the Croatian clothing sizes system for men's and women's clothing. Clothing size tables are based on major physical, constructional and auxiliary measures. The next step in structural preparation is the modelling of the basic pattern, which involves the procedures of adding and moving seams and darts, opening pattern pieces to add volume, adding creases, etc. The last step is to check the uniform's suitability. Modern 2D / 3D CAD systems enable complete computer-aided design and testing of model prototype fit, greatly accelerating the complex process of structural preparation and elaboration of a large number of models in collections.

The Optitex CAD system, was used to carry out the experimental part of the work and for realization the author's collection of uniforms for medical staff. The CAD system within the software packages of the computer system of structural preparation enables the complete development of clothing, textile and clothing design,

digitalization of cut pieces with a digitizer, digital pen, digital camera or scanner and their subsequent processing with the possibility of modelling, grading and patterns adjustment [10].

2.5 The textile material parameters

The material parameters that depend on the outcome of the 3D simulation of the model are the physical and mechanical properties, the bending and shear stiffness, shrinkage, elongation, mass, thickness, and surface friction. The goal of defining the value of the physical and mechanical properties of a textile material is ultimately to obtain a realistic computerized 3D model of the garment. Table 1 provides information on the selected textile material, twill fabric, as a conceptual design for medical uniforms. The raw material of the twill is 65% cotton, 31% polyester fiber and 4% elastane fiber.

Table 1: Values of physical and mechanical properties of twill fabric

Tensile properties		Bending properties		Shear properties	Compression properties	Mass
EMT-x [%]	EMT-y [%]	B-x [gf*cm]	B-y [gf*cm]	G [dyn/cm]	TO [cm]	W [g/m ²]
69.6	423	72.8883	36.2970	72.19	0.0996	2.5336

3. Results

The results combine the preferences of medical uniforms users and the design proposal for different types of female and male body based on a questionnaire and body shape analysis. Particular attention was paid to the requirements of the respondents, for example the problem of dressing / removing the blouse over the head was solved by zippers on the front of the blouse or on the shoulder seam. The neckline, the length of the garment, the cut, the length of the sleeves and the buttoning are also adjust to the requests of the subjects to fit the body shape.

3.1. Results of the survey

The ratio of male to female respondents is 87.6% female and 12.4% male. The most common clothing sizes in the male respondents were 54 and 60, in the female respondents the size 38. When asked how satisfied they were with the existing uniforms, 50% answered partially, 24.5% were satisfied with the uniforms and 25.5% were dissatisfied. As a reason for dissatisfaction and desired change, the main problem was the model's fit towards the body (comfort and size of the model). When choosing a medical uniform, female respondents prefer a set of pants and blouses (68.2%). Male respondents selected a set of pants and shirts (68%). Overall, 12.4% of respondents (both sexes) chose the mantle. As an additional part of the uniform, 62.7% of respondents choose a T-shirt. When selecting textile materials, hygiene was the first to consider, because of the workplace environment, so 55.7% of respondents choose materials that can be maintained by washing at 90 ° C (raw material composition: 100% cotton) [9].

The results of the survey do not show major differences in the desirable properties of the uniforms in the area of colour and the design of the uniforms themselves, but the problems with the offer of sizes and / or the suitability of the uniforms and the supply of materials are highlighted. For different body shapes, such as smaller bodies, wide hips, etc., there are large variations in the proportions of the garment.

3.2. Results of medical uniform design proposal

The following figures show simulations of medical staff uniform proposals for "rectangle" type of female and "V" type of male body with technical drawings.



Figure 4: Medical uniform for “rectangle” body type [4]



Figure 5: Medical uniform for “V” body type [4]

4. Conclusion

The topic of the article is design of uniforms for medical staff according to the different body types. The article is based on research about interests and needs of people in health service, including secondary school and college students, and health service employees via survey questionnaire. Survey questionnaire is highly efficient way of collecting research data and information. There is noticeable absence of male respondents in all categories (pupils, students, employees) regardless of well survey response. Based on survey results, design proposal for uniforms was made.

The results of the questionnaire are different than expected. Although a larger proportion of respondents includes a students and the expected changes in thinking and desires related to the design of the uniform compared to previous ones, the design requirements are in line with the current one. The biggest deficiencies are the raw material composition and the range of clothing sizes.

When designing uniforms, the main motive was functionality. Most of the surfaces on garments were used for the purpose of pockets, prominent or hidden. In order to maximize the utilization of the surfaces, the layering

of the material, ie the series of pockets, is noticeable. In addition to functionality, the design of the uniforms was based on the shapes of the human body. Based on the gender division of the body shape, for each shape the goal was to strike a balance between the upper and lower body.

References

- [1] Dugač, Ž.; Horvat K., Službeno, praktično i elegantno: O uniformama sestara pomoćnica - medicinskih sestara od 1920-ih do 1940-ih godina u Hrvatskoj, *Acta med-hist Adriat*, 11. (2013) 2, 251-274, ISSN: 1334-6253 (Online)
- [2] Ritchie, L.; Do clothes maketh the nurse?, *Kai tiaki Nursing New Zealand*, 21 (2015) 10, 31, ISSN: 0028-8535
- [3] Singh, S.: Impact of color on marketing, Available from https://etd.ohiolink.edu/rws_etd/document/get/osu1218038251/inline Accessed: 2018-08-07
- [4] Singh, S.: Impact of color on marketing, Available from https://etd.ohiolink.edu/rws_etd/document/get/osu1218038251/inline Accessed: 2018-08-07
- [5] Ujević, D. et al.: *Hrvatski antropometrijski sustav – priručnik*, Zrinski d.d., Čakovec, (2006)
- [6] Petrak, S.; Mahnić, M.; Rogale, D.: Impact of Male Body Posture and Shape on Design and Garment Fit, *Fibres & Textiles in Eastern Europe*, 23 (2015) 6, 150-158, ISSN: 1230-3666
- [7] Petrak, S.; Mahnic Naglic, M.; Sikic, M.: Garment Collection Designed According to Female Body Types and Mass Customization Concept, *Book of proceeding of 8th International Textile Clothing & Design Conference - Magic World of Textiles*, Dragčević, Z.; Hursa Šajatović, A.; Vujasinović, E. (ur.). Zagreb, University of Zagreb Faculty of Textile Technology, Dubrovnik, Croatia, 2016, 406-411, ISSN: 1847-7275
- [8] Lutz, W.; Kartsounis, S.; Carosio, C.: *Transforming Clothing Production into a Demand-Driven, Knowledge-Based, High-Tech Industry*, Springer-Verlag London Limited, ISBN: 9781848826076, London, (2009)
- [9] Simmons, K.; Istook, CL.; Devarajan, P.: Female figure identification technique (FFIT) for apparel Part I: Dscribing female shapes, *Journal of Textile and Apparel, Technology and Management*, 4 (2004) 1, 1-16, ISSN: 15330915
- [10] Zmeškal, K.: Dizajn i projektiranje kolekcije individualiziranih modela uniformi za medicinsko osoblje, Diplomski rad, Sveučilište u Zagrebu Tekstilno-tehnološki fakultet, Available from <https://urn.nsk.hr/urn:nbn:hr:201:918251>, Accessed: 2020-02-17
- [11] Hu, J.: *Computer technology for textiles and apparel*, Woodhead Publishing Limited, ISBN: 9781845697297, (2011)

Authors:

Katarina ZMEŠKAL, mag. ing. des. text. (corresponding author)
University of Zagreb Faculty of Textile Technology
Prilaz Baruna Filipovića 28a, 10000 Zagreb, Croatia
Phone: +385 95 500 8822

E-mail: katarina.zmeskal@gmail.com

Prof. Slavenka PETRAK, Ph.D.
University of Zagreb Faculty of Textile Technology, Department of Clothing Technology
Prilaz Baruna Filipovića 28a, 10000 Zagreb, Croatia
Phone: +385 1 3712 543

E-mail: slavenka.petrak@tff.unizg.hr

ELEMENTS OF TRADITIONAL CHINA IN COMPUTER DESIGN OF AUTHOR'S FASHION CLOTHING COLLECTION

Ana-Marija GUŠA; Slavenka PETRAK & Maja MAHNIĆ NAGLIĆ

Abstract: *The paper presents a computer design of a unique textile pattern inspired by traditional Chinese motifs and clothing and the development of an original women fashion clothing collection with application of the created textile pattern in different variations. Using the CAD system for computer design and digital drawing, a unique motif for digital textile printing application was created. A women clothing collection of seven model was designed with all the sketches and technical drawings. During the collection computer design process, possibilities of connecting and applying digital textile patterns to model sketches were investigated. Complete clothing patterns development process was performed using CAD system for 2D/3D clothing design. 3D simulations of clothing models were performed to test the construction and patterns modelling and to analyse impact of textiles with different physical and mechanical properties on shape and visualization of designed clothing models. The designed digital textile pattern was applied to the computer 3D clothing prototypes, where the possibilities of positioning and transformations of textile pattern directly on the 3D prototype were explored with the aim of adapting the pattern to the clothing models form and shape and achieving continuity of motifs on the joining segments. The application of CAD systems in construction preparation process enables the improvement of computer prototypes at different stages without making a real prototype that does not go on sale later, and thus contributes to the sustainability of the clothing industry. The presented development of the pattern for digital printing and its applications directly within the contours of the cutting parts represent a sustainable solution for the negative impact on the environment that traditional methods of clothing and printing production have.*

Keywords: *computer design, 3D simulation, computer prototype, digital textile pattern*

1. Introduction

The clothes we wear are part of our personal identity. In the past, people wore traditional clothes and costumes, depending on the country they come from, while today we wear the so-called "Western" style of dress. Creating a modern style, designers often seek into the tradition for the inspiration, so today modern fashion increasingly contains elements of national costumes or is fully designed and developed as a modern version of traditional clothing [1-3]. Chinese culture and tradition are a frequent inspiration to designers, and Chinese traditional clothing has greatly influenced the design of Western clothing. Two historical periods of Chinese dress stand out, the Qing Dynasty (1644-1911) in which women wore the Han suits and today very popular cheongsam, and the People's Republic of China (1949-present) period with a characteristic Mao suit [4].

The technology development and the improvement of production processes have enabled the clothing industry to respond to rapid changes in trends, but also led to increasing environmental pollution by mass production of non-fitting clothing, prototyping at various stages of production that are not sold but go to waste, different finishing, painting and printing processes, etc. The application of CAD systems and software packages for the textiles and clothing design enables a realistic presentation of the designer's idea and computer three-dimensional visualization of the garment on a body of a targeted size and shape. In this way, the designer can virtually refine his idea without creating trial models, which significantly affects the time and cost of developing and creating new clothing collections [5].

The development of each garment model begins with a sketch and art project that represents the design according to which the garment pattern is constructed and modeled. Art project has to be aesthetically appealing to the observer and it must be structurally clear and legible [6]. Clarity and precision in the creation of art projects can be achieved by using specialized CAD programs for clothing design. The collection presented in the experimental part of this paper, was designed using Adobe Illustrator [7]. Modern CAD systems for 2D/3D clothing design, in addition to garment pattern construction and modeling, enable physical simulation of a garment on a body model with the application of physical and mechanical properties of textile material. Computer 3D garment prototypes enable verification of garment pattern construction and modeling, the garment pattern fit analysis according to the body size and type and the investigation of the impact of textile materials with different properties on the garment model appearance and shape, before making a real prototype model [8,9].

2. Experimental

The experimental part of the paper presents the computer design and development of a textile pattern in the form of an illustration inspired by traditional Chinese clothing. The main motif of the illustration is a woman, with characteristic Asian facial features, shown in her traditional clothes with a minimalist landscape in the background. The illustration was designed as a basis for the textile patterns that could be printed on the garment cutting parts using digital printing technology. Furthermore, computer-designed art projects and technical sketches of five models of clothing items were created. From an aesthetic point of view art projects were used to analyse suitability of the pattern and parts of the pattern motifs for application to individual garment form and cutting parts shapes. Based on art projects and technical sketches, 2D/3D CAD system for clothing design, was used to construct and model cutting pattern the collection. The created textile pattern was applied to computer 3D prototypes. The possibilities of application and necessary modifications of flat 2D illustration to a three-dimensional garment form were investigated in order to achieve the integrity of the motif and pattern continuity on the joining segments.

2.1 Computer design of the author's collection and a unique textile pattern

The inspiration for the textile pattern is China during the reign of the Yin dynasty, between 266 and 420. The illustration was designed with a motif of a woman, recognizable Asian facial features, in traditional clothing worn during the Jin Dynasty. In the Jin period, aristocratic women lived unfettered lifestyles, no longer being the cruel roles imposed on them by society, but began to engage in art, literature, and metaphysics, completely defying the feudal virtues of women. This carefree lifestyle has developed women's clothing in accommodating extravagant and embellished fashion with characteristic wide sleeves, long swaying dresses and elegant and magnificent hair ornaments [10]. The making of the woman's motif began with drawing of eyes with the folded eyelids, characteristic of Asian women, to which the rest of the face, lips, nose and eyebrows, as well as the head shape, ears and hair, were added. The light face characteristic for Chinese women of that time is especially prominent. A traditional clothing combination in pastel shades of purple and blue has been added to the drawn body silhouette (Figure 1).



Figure 1: Computer design of a unique textile pattern inspired by traditional China

The motif of the woman is placed in the focus, the very middle of the illustration with a minimal background. To add an dynamic element to the illustration, a bright red cherry blossom canopy motif was created on the left. The dynamics and mobility of the motif is achieved by multiplying the element of the blossoming cherry branch (Figure 1), which was folded into a composition at different rotation angles in order to obtain the illusion of a part of the tree.

The clothing collection is designed as a blend of traditional Chinese clothing with modern. Five models of modern cuts were designed and used to investigate the possibilities of applying the same textile pattern in different variations. By scaling and rotating the created pattern, complete or only a part of the illustration with Chinese motifs was applied to each of the clothing models. Special attention is paid to the adjustment of the textile pattern according to the garment model cut in a way that the selected part of the illustration or motif follows the shape of the model. The pattern size corresponds to the shape and size of the cut parts (Figure 2).

Based on the created sketches, technical drawings of clothing models were made, as preparation for the construction and modelling of garments cutting patterns (Figure 3).



Figure 2: Author's fashion clothing collection

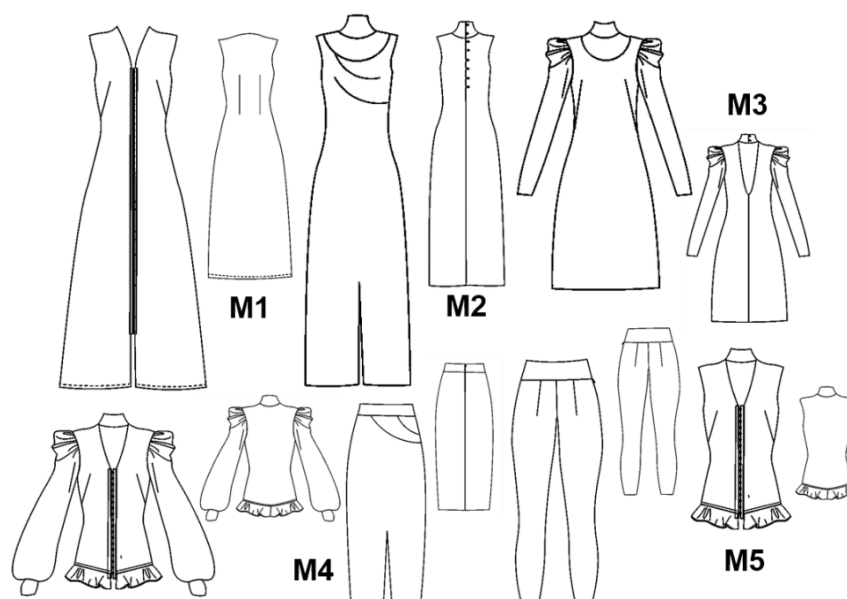

Figure 3: Technical drawings of garment models in the collection

2.2 Computer 2D/3D design of fashion clothing collection

The cutting patterns of the garment models in the collection were constructed using the 2D / 3D CAD system Optitex. All necessary parameters of cutting parts and joining segments for 3D simulation process were defined. 3D simulations were performed for the purpose of verifying the pattern construction and modelling, testing the garment fit on the body model, and selecting textile materials whose physical and mechanical properties enable the realization of the targeted garment form and appearance while ensuring functional use values. In this sense, for each model, 3D simulations with the application of three different textile materials were performed. Based on the results, the combinations of materials that best achieve the target form of the garment model were selected. Computer analysis of garments fit on body models of a given size was performed by using the plane cross-section method and analysis of tensile stress of the garment based on the geometric deformation of the computer prototype on the body model.

From the aesthetic aspect of the designer's idea, the application of the previously created textile pattern was explored. The possibilities of processing samples directly on computer 3D prototypes were investigated, whereby the size and position of the textile pattern were adjusted according to the size and shape of the cutting parts, in order to achieve the correct visualization of the 2D illustration on the 3D garment geometry and the continuity of the illustration on the joining segments.

3. Results

Figure 4 shows the results of author's fashion collection garments pattern modelling with the application of a unique textile pattern inspired by traditional Chinese motifs. The size of the pattern and the segment of the illustration that dominates the visualization depends on the individual garment in the collection. Due to the geometry and garment cut lines, the parts of the textile pattern had to be segmented and transformed so that when joined into a three-dimensional shape, the illustration remained complete and visually identical to the original flat shape.

The positioning and fitting of the textile pattern was performed directly within the contours of the garment cutting parts. The garment cutting pattern prepared in this way can be directly printed on the textile material by digital printing technology. This method combines two processes, textile printing and cutting patterns plotting, which directly affects the time of production and the consumption of dyes and materials in the production process. The simulation results and computer 3D prototypes of the author's mini collection developed using the 2D/3D CAD system are shown in Figure 5.



Figure 4: The results of garments pattern modelling with the application of a textile pattern



Figure 5: Computer 3D prototypes of the author's mini collection

4. Conclusions

The application of CAD systems in the design of fashion collections enables fast development of ideas and variations of models, precise production of sketches and technical drawings and creation of high quality illustrations for application in the form of textile patterns. The development of the author's collection presents a combination of traditional and modern and shows traditional Chinese clothing in a new modern world. The

application of CAD systems for 2D/3D clothing design and the development of computer prototypes have enabled various garment fit testing, based on which the behavior of a garment in real conditions can be predicted with sufficient precision. The application of a textile pattern within the contours of the cutting parts, enables precise positioning, manipulation and fitting on the joining segments according to the designer's idea. This reduces the need to make realistic prototypes at different stages of collection development, which has a positive impact on time, cost and environment, since the testing prototypes models do not go on sale but end up as waste. Digital printing of a textile pattern within the contours of the cutting parts also affects the time and greatly reduces the consumption of dyes, making the process more sustainable and cheaper than the traditional one. The application of CAD technologies in the fashion industry also has a social aspect. Due to the coronavirus pandemic in 2020, the whole world stopped and many economies were negatively affected, including the fashion world. Not only has the entire production in the textile and clothing industry stopped, but it has also become a problem how to revive and return production and sales to normal. The great danger of infection arises from the very fact of trying on clothes in cabins, as well as in the production facilities, where workers are in very cramped spaces and the garment passes through a multitude of hands before its production is completed. One of the solutions can be a new digital production method using 2D/3D CAD systems for virtual prototyping and online sales using virtual fashion shows and catalogs with 3D clothing models that can be visualized on body models adjusted to a targeted size and shape.

References

- [1] Hong, F. & Wang, X.: The Application of National Costume Elements in Modern Fashion Design, Available from https://file.scirp.org/pdf/20-1_33.pdf
- [2] Ning, S. & Qinchuan, Z.: On the Integration of National Costume Elements and Modern Costume Design, Available from https://www.shs-conferences.org/articles/shsconf/pdf/2014/01/shsconf_icit2013_02013.pdf
- [3] Xie, Y.: New Chinese Costume, *World Journal of Social Science Research*, 4 (2017) 4, pp. 381-384, ISSN 2375-9747
- [4] Ma, Y. & Bian, X.: Research on Chinese Influence on Western Fashion Based on Fashion Magazine from 1970-1979, *Asian Social Sciences*, 16 (2020) 2, pp. 11-21, ISSN 1911-2017
- [5] Petrak S. et al.: Computer design of textile and clothing collection – assumption of contemporary remote business, *Proceedings of 11th World Textile Conference AUTEX*, Adolphe, D. (ur.), pp. 1162-1168, ISBN 978-2-7466- 2858-8, Mulhouse, June 2011, Ecole Nationale Supérieure d'Ingenieurs Sud-Alace, Mulhouse, (2011)
- [6] Vinković, M.: *Likovno projektiranje odjeće 1*, Sveučilište u Zagrebu, Tekstilno-tehnološki fakultet, ISBN 953-96408-0-6, Zagreb, (1999)
- [7] Szkutnicka, B.: *Technical Drawing For Fashion*, Laurence King Publishing, ISBN 978-1-85-669618-0, London, 2010.
- [8] Marjanović, J. et al.: Design and computer construction of structural sleeve forms for women's clothing, *Textile and Leather Review*, 2 (2019) 4, pp. 183-195, ISSN 2623-6257
- [9] Petrak, S. et al.: Sizing and fit for swimsuits and diving suits, In *Anthropometry, Apparel Sizing and Design* 2nd ed., Elsevier, ISBN 978-0-08-102604-5, United Kingdom, 2019, pp. 255-288.
- [10] Hua, M. et al.: *Chinese Clothing*, China Intercontinental Press, ISBN 978-7508506128, (2005)

Authors:

Anamarija GUŠA
University of Zagreb Faculty of Textile Technology (corresponding author)
Prilaz baruna Filipovića 28a, 10000 Zagreb, Croatia

E-mail: ana-marija.gusa@tff.hr

Prof. Slavenka PETRAK, PhD.
University of Zagreb Faculty of Textile Technology
Prilaz baruna Filipovića 28a, 10000 Zagreb, Croatia
Phone: +(385) (1) 3712 543 Fax: +(385) (1) 3712 599

E-mail: slavenka.petrak@tff.unizg.hr

Maja MAHNIĆ NAGLIĆ, mag. ing. techn. text.
University of Zagreb Faculty of Textile Technology
Prilaz baruna Filipovića 28a, 10000 Zagreb, Croatia
Phone: +(385) (1) 3712 543 Fax: +(385) (1) 3712 599

E-mail: maja.mahnic@tff.hr

INFLUENCE OF SOCIAL MEDIA ON FASHION INNOVATIVENESS

Elena TOMOVSKA

Abstract: *Fluent and ever changing fashion is a key concept underpinning the success of clothing products. The individuals' acceptance of certain fashions can be described via their fashion innovativeness. Social media has become a powerful communicating tool for the fashion industry, providing an instant, democratic, user-generated dissemination of fashion trends, particularly with the younger generations. Image-centred social media, such as Instagram are particularly well adopted for fashion communication. This research aims to investigate the influence of Instagram on the acceptance of fashion trends, i.e. on the fashion innovativeness of GenZ. The research used an electronic questionnaire distributed to 120 participants, aged 16 to 23 years. A domain-specific fashion innovativeness scale was used to determine the participants' fashion innovativeness index. A commercially available tool for measuring the reach of global and local fashion influencers was used to comprise a list of influencers used in the research. Cluster analysis was used to identify Instagram influencers impacting fashion innovativeness and the use of Instagram as a fashion information channel.*

Keywords: *fashion innovativeness, social media, Instagram, Generation Z.*

1. Introduction

As a social and cultural phenomenon the fashion sector plays an important role in the contemporary economy. The advent of the Internet, and the Web 2.0 in particular, has changed both the way consumers buy and how they think [1,2]. The online environment is an efficient tool in all the stages of the buyer decision making process – information gathering, as well as shopping [3].

Developed in 2010 Instagram defines itself as “a fun and quirky way to share your life with friends through a series of pictures. Snap a photo with your mobile phone, then choose a filter to transform the image into a memory to keep around forever” [4]. The visual form of the presented content is particularly well adapted to the fashion industry. With an audience of over 1 billion active users [5] it offers fashion marketers an unprecedented access to consumers. The core group of Instagram users comprises of 18 to 34 year olds, encompassing two generational cohorts: generation Y (born before the year 2000) and generation Z (born after the year 2000). While the digital fashion experiences of generation Y have been explored [6,7], little information can be found on the upcoming generation Z.

The phenomenon of fashion diffusion is a well-known concept in fashion theory [8]. The model of diffusion of fashion innovation, as described by Rogers [9], implies that fashion spreads gradually from the fashion innovators to early adopters, early majority, late majority and laggards. An important role in the diffusion of fashion is attributed to fashion opinion leaders. Opinion leadership has been defined in many ways, yet the concept is consistently associated with influence [10] and information sharing [11]. With that in mind opinion leaders are persons who are regarded by a group, or by other people, as having expertise and knowledge and who are considered as appropriate sources for information and advice, while having an unequal amount of influence on the decisions of others. In the world of social media the influence of opinion leaders takes various forms, covered under the portmanteaux of “influencer”. On the one hand there are the traditional opinion leaders in the face of celebrities. Social media has transformed the celebrities' ability to manage their images online and to connect directly with their consumers, producing human brands valuable in product endorsement [12]. On the other hand new players in the face of fashion bloggers have occurred. Bloggers develop and maintain an image and relationship with their audience which often translates into an ‘expert’ or ‘celebrity’ status amongst readers, creating a human brand through affective-based networks [13]. They are one form of micro-celebrity who accumulates a following on blogs and social media through the textual and visual narration of their personal, everyday lives, upon which paid advertorials for products and services are premised [14]. The new type of opinion leader with crowds of online followers has been called citizen influencers by some researchers [15]. As the main characteristic of social networks is that they tend to be viral and of immediate response, influencers can contribute towards fast and global dissemination of fashion trends. Even if mass fashion dissemination is not a new concept [8], this new possibility for instant communication opens new alleys for consumers and marketers alike. From the aspect of consumers, access to information on fashionable items can make them more fashion forward.

Although the industry has widely adopted this particular social media tool, the academic research on Instagram as a fashion communication tool lags far behind. The majority of the studies analysed brands' strategic use of Instagram, rather than focusing in the consumers' perception of the marketing information. Social media and Instagram have been investigated as a tool for disseminating fashion trends, by both luxury [16,17], and high street brands [2, 18]. The purpose of this research is to investigate the influence of Instagram on the acceptance of fashion trends, i.e. on the fashion innovativeness of Generation Z by determining: (a) how groups with different fashion innovativeness use Instagram as a tool for information search of fashion trends and (b) which influencers are used for disseminating information among groups with different fashion innovativeness. The research is limited to a developing market, namely N. Macedonia.

2. Method

Using a convenience sampling method data was gathered by surveying female university students. The argument that a sample relevant to the universe of a theory could constitute a test of that theory supports employing a convenience sample, rather than having a random sample from the total population of young people [19]. Thus, the target population of the study were young consumers who are currently active users of Instagram. Research has indicated that core users of Instagram with high frequency of usage are 18 to 23 year-olds and that women use Instagram more than men [20]. In addition, women are consistently found to be heavier consumers of clothing [21].

An online questionnaire was distributed in September 2018. Links to the questionnaire were shared on student study groups on social media at the largest N. Macedonian university, Ss Cyril and Methodius -Skopje. As a state university, the demography of students of the university is fairly representative of the national youth population. Out of 120 questionnaires distributed, 97 useful, fully answered, questionnaires were returned. Of the respondents 96% had used Instagram daily, while 4% weekly. The questionnaire measured the frequency of using Instagram in searching for information on fashion trends, influencers followed, and fashion innovativeness.

To measure domain-specific innovativeness for fashion goods, this study used a scale developed by Goldsmith and Hofacker [22]. The scale consists of six five-point Likert-type questions which ranged from "strongly disagree" (1) to "strongly agree" (5), with higher summary scores indicating higher innovativeness. Cronbach's alpha for the scale on the set of respondents was 0.745, which suggest that the measures for the scale was internally consistent. From the scale a fashion innovativeness index was obtained, ranging from 1 (innovators) to 5 (laggards). The frequency of distribution of participants with index 1 was 19.6%, index 2 – 28.9%, index 3 – 27.8%, index 4 – 19.6% and index 5- 4.1%. Due to the age group of the population the distribution of fashion innovativeness is visibly skewed towards fashion innovators.

To determine the sources of information on fashion available on Instagram a review of influencers was made. Firstly, using a focus group of fashion students and fashion experts a preliminary list of influencers significant for the Generation Z was drawn. Secondly, using a commercially available rating from *Hypeauditor*, the list was narrowed down by criteria presented in Table 1. The criteria used popularity expressed by number of followers and communication with audiences (engagement), as well as fashion topics content.

Table 1: Fashion influencers used in the research

Profile Name	Code	Followers	Global Rank	Engagement	Fashion content
Ariana Grande	ArG	129800	8	1.44%	66%
Kylie Jenner	KJ	115800	3	4.06%	76%
Gigi Hadid	GH	43500	25	2.82%	82%
Lele Pons	LP	28700	20	7.40%	77%
Amanda Cerny	AC	22900	60	4.82%	69%
Emily Ratajkowski	ER	19700	117	3.64%	78%
Millie Bobby Brown	MBB	17600	40	12.92%	76%
Liza Koshy	LK	17400	83	6.75%	75%
Chloe Grace Moretz	CGM	15200	300	1.83%	81%
Hannah Stocking	HS	14300	146	6.40%	77%
Chiara Ferragni	CF	13500	244	2.59%	88%
Zoella	Z	10700	258	5.05%	83%
Alissa Violet	AV	8600	252	9.02%	80%
Ashley Graham	AG	7500	679	2.42%	73%
Eva Gutowski	EG	5600	677	5.87%	87%

Bethany Mota	BM	5300	911	3.74%	88%
Negin Mirsalehi	NM	5000	1128	3.31%	92%
Zorana Jovanovic	ZJ	912	13590	2.17%	98%
Viktorija Loba	VL	51	211490	5.15%	73%
Monika Potter	MP	16	724150	5.91%	75%

The influencers used in the research can be classified as: global celebrities in the entertainment and fashion industries (ArG, KJ, ER, GH, AG,CGM, MBB), global citizen influencers (Z, BM, EG, LP, HS, LK, AC, AV, CF, NM) and local influencers (ZJ, MP, VL). The following of influencers was measured on a scale from: 1-follower to 5-unacquainted with the influencer.

3. Results

As shown by their fashion innovativeness index the population used in the research consists of young, fashion conscious women. Therefore it is not surprising that Instagram was frequently used for searching fashion trends. Of the examined sample 46% followed fashion trends on Instagram daily, 25% weekly, 7% monthly and 22% less than once a month. The frequency of following fashion trends differed with groups of different fashion innovativeness ($\chi^2=40,87$, $df=12$, $p=0,000$). As can be seen from Table 2, approximately 95% of fashion innovators use Instagram for viewing fashion trends daily or weekly, whereas with groups in the later stages of fashion diffusion process the frequency falls.

Table 2: Following fashion trends on Instagram by groups with different fashion innovativeness index

Fashion Innovativeness Index	Frequency of following fashion trends (%)			
	Daily	Weekly	Monthly	Rarely
1-Innovators	73.68	21.05	0.00	5.26
2-Early adopters	57.14	21.43	7.14	14.29
3- Early majority	48.15	33.33	3.70	14.81
4-Late majority	5.26	31.58	21.05	42.11
5-Laggards	0.00	0.00	0.00	100.00

To identify Instagramers influencing fashion innovativeness and information search a cluster analysis was conducted using the variables fashion innovativeness, information search, and following an influencer on Instagram. Variables were clustered using hierarchical cluster approach. Six clusters were obtained. The dendrogram depicting the clusters is shown in figure 1. Variables are coded as per Table 1, with addition of fashion innovativeness index (MI) and searching for fashion information over Instagram (Insta).

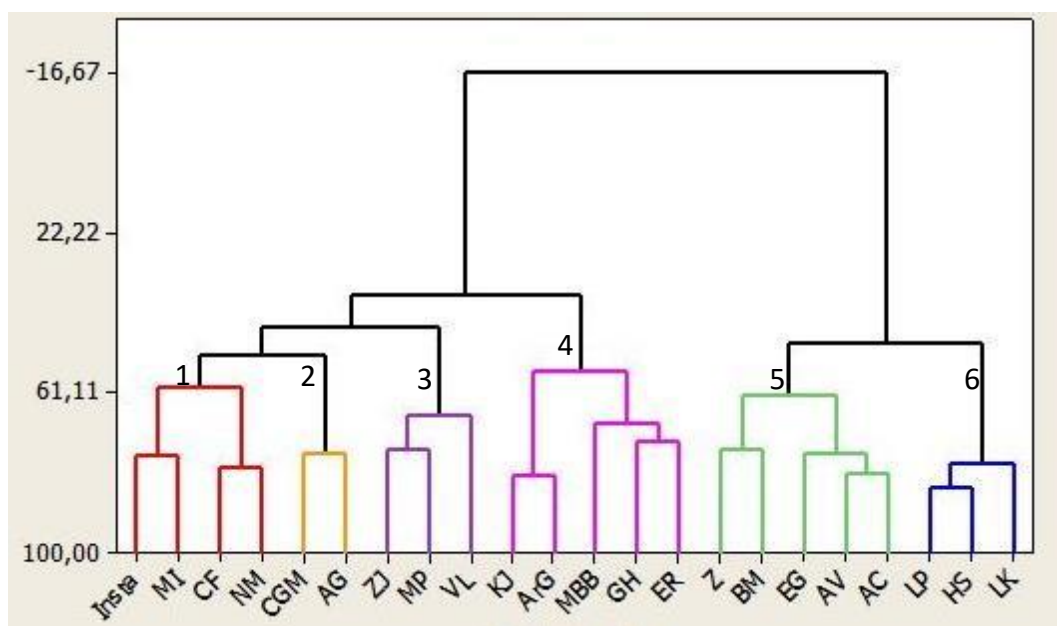

Figure 1: Dendrogram of fashion innovativeness, information search, and following an influencer on Instagram

On the first level of the dendrogram two branches can be seen. The second branch, comprising of clusters 5 and 6, contains all of the global citizen influencers. Cluster 6 contains the influencers trending at the time the research was conducted, while cluster 5 influencers who became famous through social media other than Instagram (e.g. Vine, Youtube etc.). These fashion influencers are typically involved in promoting high street fashion brands and have fashion content of around 80%. Although they had a greater number of followers among the examined population (LP-14.4% follows, HS-12.4%, BM-9.3%, LK, AV-6.2%, AC, EG- 5.2%, Z-3%), their fashion content was not recognised. These influencers typically use covert marketing strategies, while accent in the presentation is placed on other content, such as entertainment.

The second level dendrogram also has two branches, of which cluster 4 included all of the global celebrities used in the research. These were influencers with the largest number of followers (ArG-22.7%, ER-21.6%, KJ -19.6%, Gh 18.6%). None the less, they have little influence on the fashion innovativeness and the search of fashion trends amongst the examined population.

The remaining three clusters 1, 2 and 3 are the closest connected with fashion innovativeness and information search for fashion trends. The first cluster includes fashion bloggers, the second young celebrities relevant to Generation Z and the third local influencers.

To further examine the relationship a chi-square test was conducted between the following of an influencer and fashion innovativeness and information search, respectively. Table 3 shows the total number of followers of each Instagrammer (F), as well as the number of followers in groups who search for fashion information daily (FD) and with fashion innovators (FI) with the first and third cluster. No significant differences were found in the second cluster.

Table 3: Chi-square test between the following of an influencer and fashion innovativeness and information search

Cluster	Profile code	F (%)	Information search				Fashion innovativeness			
			FD (%)	χ^2	df	p	FI (%)	χ^2	df	p
1	CF	9.3	18.2	25.671	12	.012	15.8	19.241	16	.256
1	NM	7.2	15.9	21.221	12	.047	21.1	24.029	16	.089
3	ZJ	14.4	18.2	26.463	12	.009	26.3	19.801	16	.229
3	MP	15.5	22.7	25.900	12	.011	31.6	30.794	16	.014
3	VL	15.5	25.0	13.141	12	.359	21.1	23.209	16	.108

The first cluster includes fashion bloggers. The fashion content of their Instagram profiles is around 90%. Although they are of a lower global rank (Tab.1) and have fewer followers in the examined population (CF-9.3%, NM-7.2%) their specialised content makes them a popular source when searching for fashion information. In fact, with persons who search for fashion information daily they are significantly more popular than in the general population, as their number of followers doubles (CF -18.2% of followers, NM – 15.9%). This indicates that even though the young generation has greater fashion awareness in general, fashionistas are a distinct subculture. For this group Instagram presents a tool through which global trends can be distributed and followed daily. However no significant differences were found regarding fashion innovativeness.

The third cluster consisted of local and regional citizen influencers (ZJ and MP) and local celebrities (VL). Due to language barriers their influence is localized. Although their global rankings are low, they are rated highest in the local communities. Their influence can also be seen from the parameter of engagement (Tab.1) which describes the level of communication with audiences, and is similar or higher than that of global celebrities. Similarly to members of the first cluster they influenced the search for information and their popularity was higher among persons who search for fashion trends daily compared with the total population. Moreover, local citizen influencers from this group were the only ones where significant differences regarding fashion innovativeness were found. Fashion innovativeness is a complex issue that depends not only on the available information on trends, but also on various posed restraints, whether monetary or physical availability in local retail. Therefore, local citizen influencers who experience the same environmental and cultural cues exert greater influence on fashion innovativeness.

4. Conclusions

New mass communication technologies, such as Instagram, present a hereby unparalleled channel for the distribution of fashion information, providing a possibility for a democratization in the fashion sector and a rapid diffusion of fashion. Influencers are the opinion leaders in this newly established fashion communication. This

research investigated the influence of Instagram on the acceptance of fashion trends, i.e. on the fashion innovativeness of Generation Z. While information on fashion on Instagram is available in both overt and covert presentations from many players, fashionistas remain a distinct subculture. They can easily recognize and follow influencers with relevant fashion content, whose popularity in the total Instagram universe is limited. However, local citizen influencers, who are subjected to the same real-life environmental and cultural cues in a certain community are the only ones who influence fashion innovativeness.

References

- [1] Brashear, T.G.; Kashyap, V; Musante, M.D. & Donthu,N.: A Profile of the Internet Shopper: Evidence from Six Countries, *Journal of Marketing Theory and Practice*, **Vol. 17** (2009) No.3, pp.267-282, ISSN: 10696679
- [2] Arriaga J.; Andreu. D. & Berlanga V.: Facebook in the low-cost fashion sector: the case of Primark, *Journal of Fashion Marketing and Management: An International Journal*, **Vol. 21** (2017) No.4, pp.512-522, ISSN: 1361-2026
- [3] Choi, J. & Park, J.: Multichannel retailing in Korea, *International Journal of Retail & Distribution Management*, **Vol. 34** (2006) No.8; pp. 577 - 596, ISSN: 0959-0552
- [4] Anon.: What Is Instagram? Available from [http: https://instagram.com/about/2013](http://https://instagram.com/about/2013) Accessed 2018-06-15
- [5] Anon, Instagram Users Available from <https://www.statista.com/statistics/253577/number-of-monthly-active-instagram-users/> Accessed 2018-07-10
- [6] Ruane, L. & Wallace, E.: Generation Y females online: insights from brand narratives, *Qualitative Market Research: An International Journal*, **Vol. 16** (2013) No. 3, pp. 315 - 335, ISSN: 1352-2752
- [7] Boardman, R. & McCormick, H.: Shopping channel preference and usage motivations: Exploring differences amongst a 50-year age span, *Journal of Fashion Marketing and Management: An International Journal*, (2018) **Vol. 22** (2018) No.2, pp. 270-284, ISSN: 1361-2026, ISSN: 1361-2026
- [8] Frings, G.S.: *Fashion from concept to consumer*, Prentice Hall, ISBN: 0133066223, New Jersey, (1987)
- [9] Beaudoin, P.; Lachance, M.J. & Robitaille, J.: Fashion Leaders' and Followers' Attitudes Toward Buying Domestic and Imported Apparel, *Journal of Fashion Marketing and Management*, **Vol.7** (2003), No.1, pp.23-30, ISSN: 1361-2026
- [10] Flynn, L.R.; Goldsmith, R.E. & Eastman, J.K.: Opinion leaders and opinion seekers: two new measurement scales, *Journal of the Academy of Marketing Science*, **Vol. 24** (1996) No. 2, pp. 137-47, ISSN: 00920703
- [11] Gilly, M.C.; Graham, J.L.; Wolfinbarger, F.M. & Yale, L.J.: A dyadic study of interpersonal information search, *Journal of the Academy of Marketing Science*, **Vol. 26** (1998) No. 2, pp. 83-100, ISSN: 00920703
- [12] Kowalczyk M. C. & Pounders K.: Transforming Celebrities through Social Media: The Role of Authenticity And Emotional Attachment, *Journal of Product & Brand Management*, **Vol. 25** (2016), No. 4, pp. 345-356, ISSN: 1061-0421
- [13] Brydges T. & Sjöholm J.: Becoming a personal style blogger: Changing configurations and spatialities of aesthetic labour in the fashion industry, *International Journal of Cultural Studies* , Vol.1 (2018), No.1, pp.1-21
- [14] Abidin C.: Visibility labour: Engaging with Influencers' fashion brands and #OOTD advertorial campaigns on Instagram, *Media International Australia*, **Vol. 161** (2016) No. 1, pp. 86-100, ISSN: 1329878X
- [15] Martensen, A.; Schack, B. S. & Zahid, L. A.: How citizen influencers persuade their followers, *Journal of Fashion Marketing and Management: An International Journal*, **Vol. 22** (2018) No. 3, pp. 335-353, ISSN: 1361-2026
- [16] Kusumasondjaja, S.: Exploring the role of visual aesthetics and presentation modality in luxury fashion brand communication on Instagram, *Journal of Fashion Marketing and Management: An International Journal*, **Vol. 24** (2019) No. 1, pp. 15-31, ISSN: 1361-2026
- [17] Geissinger, A. & Laurell, C.: Tracing brand constellations in social media: the case of fashion week Stockholm, *Journal of Fashion Marketing and Management: An International Journal*, **Vol. 22** (2018) No. 1, pp. 35-48, ISSN: 1361-2026
- [18] Bonilla, M.; Arriaga, J.L. & Andreu, D.: The interaction of Instagram followers in the fast fashion sector: The case of Hennes and Mauritz (H&M), *Journal of Global Fashion Marketing*, (2019) DOI: 10.1080/20932685.2019.1649168, ISSN: 20932685, 23254483
- [19] Park, H.; Burns, L.D. & Rabolt N.J.: Fashion innovativeness, materialism, and attitude toward purchasing foreign fashion goods online across national borders: The moderating effect of internet innovativeness, *Journal of Fashion Marketing and Management*, **Vol. 11** (2007) No. 2, pp. 201-214, ISSN: 1361-2026
- [20] Chen, H.: College-Aged Young Consumers' Perceptions of Social Media Marketing: The Story of Instagram, *Journal of Current Issues & Research in Advertising*, **Vol. 39** (2018) No. 1, pp. 22-36, ISSN: 1064-1734

- [21] Goldsmith, R.E.: Characteristics of the heavy user of fashionable clothing, *Journal of Marketing Theory and Practice*, **Vol. 8** (2000) No. 4, pp. 21-8, ISSN: 10696679
- [22] Goldsmith R.E.; Moore, M.A. & Beaudoin P.: Fashion innovativeness and self-concept: A replication, *Journal of Product & Brand Management*, **Vol. 8** (1999) No. 1, pp. 7-18, ISSN: 1061-0421

Author:

Dr. Elena TOMOVSKA
Faculty of Technology and Metallurgy, University Ss Cyril and Methodius
Ruger Boskovic 16, 1000 Skopje, R.N. Macedonia
Phone: +(389) (2) 3088 201 Fax: +(389) (2) 3065 389

E-mail: etomovska@tmf.ukim.edu.mk

COMPARASION OF CROATIAN AND CHINESE CLOTHING SIZE SYSTEM WITH REFERENCE TO CHARACTERISTIC BODY PROPORTIONS

Darko UJEVIĆ; Blaženka BRLOBAŠIĆ ŠAJATOVIĆ; Yu BIN & Zhu FEICHAO

Abstract: The paper describes the problem of anthropometric measurement of body sizes with an emphasis on clothing size system and the development and system of clothing size characteristics of Croatia and China Sizing system for male upper clothing is shown for both countries, and differences in the labelling of clothing sizes are listed.

Keywords: clothing size, Croatia, China, body proportions, men's shirt

1. Introduction

Body size and shape form a set of measurable traits resulting from the expression of genes and their interaction with various environmental factors during human life. These characteristics are measured by a continuous measuring scale and take on a number of values such as: height, body length, and the width and scope of certain parts of it. [1].

Different systems are used to mark clothing and footwear sizes worldwide, creating a range of concerns and difficulties for manufacturers. This is highly present in cases of placing the same products in different markets where customers are given a dilemma due to their lack of understanding of clothing and footwear sizes, and are often confused because they do not recognise the size label or do not give them sufficient quality information. Additional customer confusion is caused by the fact that each product is designed and clothing construction according only to it with characteristic peculiarities, and has different accessories due to the garment fit and achieving a certain form of clothing. Because of all of the above, it is in the interest of both buyers and manufacturers of clothing and footwear, to agree on unique ways of marking clothing sizes and footwear, which would be valid in all markets and which would give customers clear and unambiguous information, and allow manufacturers to potentially sell more [2].

2. Designation of garment sizes

Pictogram symbolically presents a silhouette of human body on which position and values of the designated body measurements can be shown. For some body measures, a modified pictogram is used, such as a modified pictogram, for the underbust girth lower for women.

In order to make the presentation of body measures on the pictogram uniform, all measures relating to the circumference of individual parts of the body shall be marked in a circle on the left side of the pictogram, and measures relating to the height of the body or length of body parts shall be indicated in a circle on the right side of the pictogram.

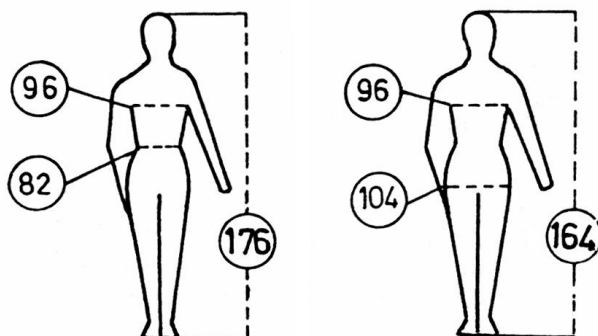

Figure 1: ISO designation of garment sizes a) for men's jacket b) for women's dress

According to the ISO systems the garment size designation for men's jackets, suits and women's jackets, coats and similar garments comprises. The garment size for men's trousers comprises two designated body measurements, while the designation for sweaters and similar garments comprises only one designated body measurement.

Examples of garment size designations according to the ISO systems are shown in pictograms on figure 1. and the measurements are expressed in cm.

Interest in designation of garment sizes will increase as the number of older users is expected to double by 2030. This presents a market challenge for the garment industry as poor size determination is the main reason for the return and price reduction, resulting in significant losses [3-5].

Therefore, designation of garment sizes must be updated periodically to ensure the correct garment fit.

2.1 New Croatian standards for garment and footwear size and their designation for men's clothes

Croatian Technical Report HRI 1148:2012 refers to anthropometric measurements and sizes used in the industry of different types of clothing and footwear.

The purpose of this report is:

- to provide a thorough understanding of the classification of clothing according to size in order to improve the suitability and fit in the Republic of Croatia,
- to optimize the number of garment and footwear sizes especially designed for the Croatian population,
- to facilitate the technical cooperation between manufacturers, sellers and customers as end consumers.

As the basic starting point for a new method of designating clothing and footwear size in the Republic of Croatia the system and method of designation specified in European standards 13402-1, 13402-2 and 13402-3 have been accepted. According to EN there are eight male body types that are based on the difference between chest girth and waist girth. Based on the measurements carried out within the framework of the Croatian Anthropometric System project, it has been established that there is a part of the male population in the Republic of Croatia whose waist girth in relation to chest girth is greater than the greatest one defined according to EN 14302-3. Therefore, a new ninth male body type was proposed within the new Croatian standards for clothing and footwear [6,7].

Table 1. Male body types

	Body type	Type definition	Waist girth – Chest girth
1	Type A - very slim	Difference -20	From -22 to -18
2	Type B - slim	Difference -16	From -18 to -14
3	Type C - normal	Difference -12	From -14 to -10
4	Type D - sturdy	Difference -8	From -10 to -6
5	Type E - sturdier	Difference -4	From -6 to -2
6	Type F - corpulent	Difference -0	From -2 to +2
7	Type G - paunchy	Difference +4	From +2 to +6
8	Type H - markedly paunchy	Difference +8	From +6 to +10
9	Type I - very paunchy	Difference +12	From +10 to +14

The Croatian Technical Report (HRI 1148:2012), entitled "Anthropometric System-Measuring and Size Designation of Clothes and Footwear," published in February 2012, includes specific body measurement of the Croatian population and relies on existing European standards 13402-1:2001, 13402-2:2002 and 13402-3:2004. The Croatian sizing standard for men's upper clothing, by three body types, ranges in body height from 160 to 192, and by the chest girth (Cg) and hip girth (Hg) is shown in Table 2 [7,8].

Table 2. The Croatian sizing standard for men's clothing

Body type	Chest girth	Body height									
		160 (156-164)		168 (164-172)		176 (172-180)		184 (180-188)		192 (188-196)	
		Cg	Hg	Cg	Hg	Cg	Hg	Cg	Hg	Cg	Hg
Slim (B)	84					68	88				
	88			72	88	72	91	72	91		
	92			76	92	76	95	76	95		
	96	80	95	80	96	80	97	80	98	80	99
	100	84	99	84	100	84	101	84	102	84	102
	104	88	103	88	104	88	105	88	106		
	108	92	106	92	106	92	108	92	109		
	112			96	111	96	111	96	111		
	116			100	114	100	114	100	115		
	120					104	117				
Normal (C)	84					72	89				
	88			76	91	76	92	76	94		
	92			80	94	80	95	80	96		
	96	84	96	84	97	84	98	84	99	84	100
	100	88	99	88	100	88	101	88	102	88	105
	104	92	102	92	103	92	103	92	104		
	108	96	105	96	107	96	107	96	108		
	112			100	111	100	110	100	111		
	116			104	114	104	113	104	114		
	120					108	117				
Sturdy (D)	84					76	93				
	88			80	94	80	96	80	97		
	92			84	97	84	99	84	100		
	96	88	100	88	101	88	102	88	103	88	104
	100	92	103	92	104	92	105	92	106	92	107
	104	96	106	96	107	96	108	96	109		
	108	100	109	100	109	100	110	100	111		
	112			104	112	104	113	104	114		
	116			108	116	108	116	108	117		
	120					112	119				

2.2 Designation of garment sizes in China

1974. China are prepare the standard of determining clothing size known as GB 1335-81 which was implemented in 1981. In 1987, a national size survey was conducted in China measuring more than 14,000 men, women and children from 10 different Chinese provinces. 1991. Chinese standard of garment size was published after a long debate between garment academies, industrialists and experts.

In 1997, the Chinese standard of size determination was updated into a new version of GB 1335 -97. From 2009 the China has started to apply national standards for men GB/T 1335.1-2008" and "GB/T 1335.2-2008 for women, table 3 [9].

Table 3. China sizing standard for men's clothing

Body type	Chest girth	Body height											
		155		160		165		170		175		180	
		Cg	Hg	Cg	Hg	Cg	Hg	Cg	Hg	Cg	Hg	Cg	Hg
	76			56	58	56	58	56	58				

Y	80	60	62	60	62	60	62	60	62	60	62			
	84	64	66	64	66	64	66	64	66	64	66	64	66	
	88	68	70	68	70	68	70	68	70	68	70	68	70	
	92			72	74	72	74	72	74	72	74	72	74	
	96					76	78	76	78	76	78	76	78	
	100									80	80	82	80	82
	104									84	84	86	86	86
A	72			56	60	56	60							
	76	60	64	60	64	60	64	60	64					
	80	64	68	64	68	64	68	64	68	64	68			
	84	68	72	68	72	68	72	68	72	68	72	68	72	
	88	72	76	72	76	72	76	72	76	72	76	72	76	
	92			76	80	76	80	76	80	76	80	76	80	
	96					80	84	80	84	80	84	80	84	
100							84	88	84	88	84	88		
104									88	92	88	92		
B	72	62	64	62	64									
	76	66	68	66	68	66	68							
	80	70	72	70	72	70	72	70	72					
C	76	70	72	70	72	70	72							
	80	74	76	74	76	74	76	74	76					
	84	78	80	78	80	78	80	78	80	78	80			
	88	82	84	82	84	82	84	82	84	82	84	82	84	
	92	86	88	86	88	86	88	86	88	86	88	86	88	
	96	90	92	90	92	90	92	90	92	90	92	90	92	
	100			94	96	94	96	94	96	94	96	94	96	
	104					98	100	98	100	98	100	98	100	
	108							102	104	102	104	102	104	
112									106	108	106	108		
116											108	112		

Designation of garment sizes for men's clothing, based on the difference between breast and waist circumference. There are four body types for men: Y, A, B and C. The marking of clothing sizes is based on a label. 170/96A, indicating body height of 170 cm, 96 cm chest girth and body type A. Body height range is from 155 to 190 cm. Table 3. are shown China sizing standard for men's clothing.

In Tables 4., 5 and 6 the letter markings of clothing sizes (XS, S, M, L, XL) used worldwide and which physical measures correspond in China according to body measurements [9].

Table 4. Men's clothes (coat, T-shirt)

Standard	Size				
China	165-165/88-90	170/96-98	175/108-110	180/118-122	185/126-130
International	XS	S	M	L	XL

Table 5. Men's blouse

Standard	Size				
China	36-37	38-39	40-41	42-43	44-45
Europe	S	M	L	XL	XXL

Table 6. Men's suit pants

Standard	Size				
Size	42	44	46	48	50
Waist (cm)	68-72	71-76	75-80	79-84	83-88
Length (cm)	99	101.5	104	106.5	109

Figure 2 shows the labelling of clothing sizes according to lettermarks in different countries.

International	US/UK	China	Japan	Korea
XS	14		S 36	90
XS	14.5		S 37	90
S	15	165 88-90	M 39	95
S	15-15.5	165 88-90	M 39	95
M	15.5-16	170 96-98	L 40	100
M	16	170 96-98	L 41	100
L	16.5	175 108-110	LL XL 42	105
L	17	175 108-110	43	105
XL	17.5	180 118-122	44	110
XL	17.5	180 118-122	44	110
XXL		185 126-130		
XXL		185 126-130		

Figure 2: Marking of clothing sizes according to lettermarks in different countries

3. Conclusion

Over the years, clothing size systems have been created in different parts of the world, which vary widely in terms of the parameters on which they are based, the intervals of component size and, in particular, the way of designation of garment sizes. Designation of garment sizes can vary significantly not only from one type of clothing to another, but within the same type of clothing; not only from the country, but within the same country and even within the same trade. Garments that arise in different countries, have different shapes of size labels. According to the clothing size system for men's upperwear cloths according to Croatian Technical report and by Chinese standard, significant differences in the labelling of clothing sizes are in the range of body height, the range of chest girth and waist girth. This leads to the conclusion that the average body height of Chinese is much lower than this among the male population in The Republic of Croatia. Also the Chinese standard lists four body types, while according to Croatian Technical report there are nine body types. Size tables, which often exist, are copied by manufacturers from another country, and the justification is that the system seems to be operating in the country of origin, so why not elsewhere. Determining the size of clothes by age, the codes described as "small, medium and large" - often without a connection to body size - contribute to a large number of sizes and cause confusion when getting ready-made clothing that fits. This large number of sizes is not actually the solution of the available choice, but rather has the effect of making it harder to get the item of the required size. Manufacturers, distributors and customers would all benefit from the unique clothing size system.

References

- [1] Ujević, D. et al.: *Hrvatski antropometrijski sustav – Put u Europu*, Zbornik radova, Tekstilno-tehnološki fakultet Sveučilišta u Zagrebu, Zagreb, ISBN 953-7105-06-7, (2004)
- [2] Ujević, D. et al.: Normizacija, antropometrijski pregledi i Hrvatski antropometrijski sustav, *Tekstil*, **55** (2006) 10, pp. 516-526
- [3] Ujević, D.; Szivoczka, L.; Hrastinski, M.: Body Anthropometry, Clothing Sizes and Croatian Anthropometric System, *the 15th Congress of the European Anthropological Association*, Budampest, (2006)
- [4] Winks, J.: *Clothing sizes, International standardization*, The Textile Institut, ISBN 1870812727, (1997)

- [5] Aldrich, W.: History of sizing system and ready-to-wear garment, *Sizing in Clothing, Developing effective sizing for ready-to-wear clothing*, The Textile Institut, Woodhead Publishing Limited, Cambridge, ISBN-13: 978-1-84569-034-2, England, (2007), pp.1-56
- [6] HRN ISO 3635:2012 (MOD EN 13402-1:2001) - Determination of clothing size system and determination of body measures and the method of their measurement
- [7] HRI 1148:2012 - Technical report- Anthropometric system - Measuring and size designation of clothes and footwear
- [8] Ujević, D.; Brlobašić Šajatović, B.; Doležal, K.: Impact of body proportions and garment sizing system on the manufacture of fashion wear, *Book of Proceedings of the 9th International Scientific-Professional Conference Textile Sciences and Economy*, Petrovic, V. (ed.). pp. 114-122, Zrenjanin, University of Novi Sad, Technical Faculty „Mihajlo Pupin“, (2018)
- [9] Available from: <https://www.codeofchina.com/standard/GBT1335.1-2008.html>, Accessed 2020-05-19
- [10] Available from: <https://www.chinabrands.com/dropshipping/article-asian-size-to-u-s-eu-size-16214.html>, Accessed 2020-05-19

Authors:

Darko UJEVIĆ
Faculty of Textile Technology University of Zagreb
Prilaz baruna Filipovića 28 a, 10 000, Croatia
Phone: +(00385) (1) 3712 541

E-mail: darko.ujevic@ttf.hr

Blaženka BRLOBAŠIĆ ŠAJATOVIĆ (corresponding author)
Faculty of Textile Technology University of Zagreb
Prilaz baruna Filipovića 28 a, 10 000, Croatia
Phone: +(00385) (1) 3712 561

E-mail: blazenka.brlobasic@ttf.hr

LINEN FABRIC DYED WITH FLAVONOID COMPOUNDS EXTRACTED FROM WASTE ONION SKIN

Ana Maria BOČAK; Ružica BRUNŠEK; Anita TARBUK & Ana SUTLOVIĆ

Abstract: The dyeing of linen fabric with natural dye was carried out with flavonoid compounds extracted from onion skin. For this research linen fabric pre-bleaching with hydrogen peroxide, as well as pre-treatment with metallic salts (mordants) on the resulting colouration were studied. Results are presented through the analysis of spectral colour properties (hue (h), chromaticity (C^*) and lightness (L^*)). Extracted flavonoid derivative has a relatively low substantivity to cellulosic material, therefore the mordant pre-treatment is necessary. Pre-treatment of the linen fabric with metal salts and dyeing process resulted in a wide range of colour hues: greyish (without mordant), yellow-brown (Al), red-brown (Cu) to dark brown (Fe). The values of the all colour hue are in the yellow - orange area ($h = 66.62 - 81.84$). The bleached fabrics retain approximately the hue value, the chromaticity increases relative to the raw samples, but an increase in the brightness value indicates that the samples obtained more vivid colours. This research contributes to the revitalization of flax fibre, to the use of flavonoids for the dyeing of cellulosic materials and to the use of bio waste as a source of dyes.

Keywords: linen fabric, natural dyes, onion skin, flavonoid compounds

1. Introduction

Linen, which is a natural based fibre, has unparalleled characteristics such as a feel of freshness and a magnificent brilliance. It is very hygienic and imparts an air of satisfaction and style to the wearer. In spite of its highly functions and features, especially in Croatia region, the cultivation of flax, which represents heritage, has been neglected [1, 2]. The eco lifestyle trend has encouraged designers to pay attention to natural fibres as well as natural dyes. Across the fashion world, there is a growing demand for natural materials of warm, harmonious colours obtained from natural sources. In the field of the application of natural dyes, textile technologists and textile designers must take care of the ecosystem. As for the plant that is the source of natural pigment for textile dyeing, it has to be waste or easily renewable. Also, the agro and food industry produces a large amount of waste which may constitute the environmental problem if it is not properly discharged. This group includes the waste onion skin source of quercetin (Figure 1), flavonoid compound known for its good dyeing properties [3, 4].

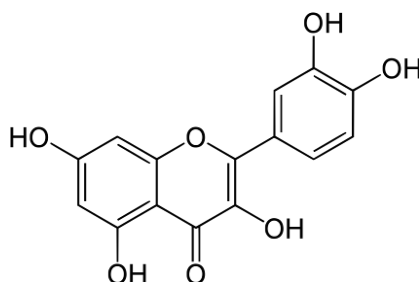

Figure 1: Chemical structure of quercetin

It is interesting for this research that onions (*Allium cepa* L.) are the second most important horticultural crop worldwide, after tomatoes, with current annual production around 66 million tonnes. Over the past 10 years, onion production has increased by more than 25%. Lately, there has been an increase in demand for processed onions which has led to an increase in waste production. Accordingly, more than 500,000 tonnes of onion waste are produced annually in the European Union, mainly from Spain, UK and Holland.

Therefore, a possible solution could be to use onion wastes as a source of textile natural dye, since onion are rich in flavonoid compounds, such as quercetin [3-5]. Quercetin, as most natural dyes belong to the mordant group of dyes. This means that in their application it is important to add metallic salts (mordants) to the dye-bath. Mordants ensure a stronger bond between the dyes and the textile material, thus enhancing fastness. In addition, mordant help to produce a wide variety of colour hues by using a single natural dye source, as natural compounds with different metal ions create differently coloured metal complexes [6, 7]. The aim of this study

was to examine the applicability of bio waste - onion skin as a source of natural dye for the linen fiber and to stimulate interest in the resulting colour on linen fabrics from a fashion point of view, in addition to the obvious environmental and economic benefits.

2. Experimental

The experimental part was performed according to the scheme in the Figure 2. The linen fabric canvas embroidery of 274 g/m² was used. Fabric was pre-bleached, mordanted and dyed with natural dye in a laboratory machine Polycolor, Mathis.

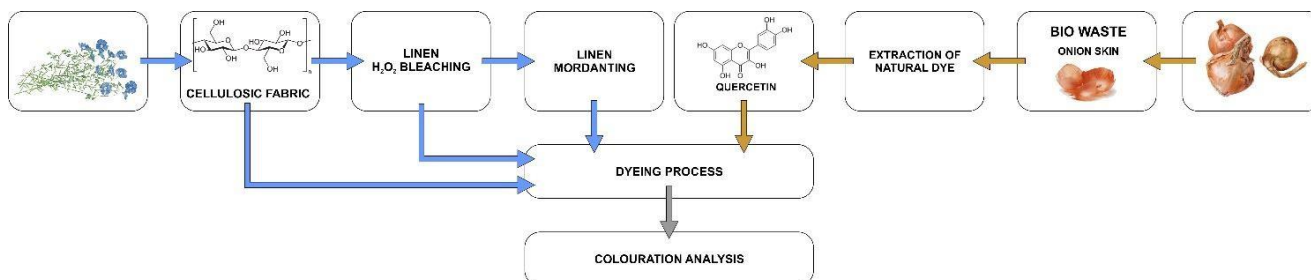

Figure 2: Schematic presentation of the experimental part of the investigation

a. Bleaching Process

Pre-bleaching process was performed at material to liquor ratio (LR) of 1:20, at 50 °C, for 40 min, pH 10. The process was carried out in a bath of the following composition: 15 g/l H₂O₂ (35%); 2 g/l NaOH; 1 g/l Heptol NWS (CHT Bezema, sequestering agent) 2 g/l Contavan ALR (CHT Bezema, stabilizing agent); 1 g/l Felosan NOF (CHT Bezema, non-ionic surfactant - wetting agent)

2.2. Mordanting Process

Pre-mordanting has been applied using potassium aluminium sulphate dodecahydrate KAl(SO₄)₂ · 12H₂O, copper(II) sulphate pentahydrate CuSO₄ · 5H₂O and iron(II) sulphate heptahydrate FeSO₄ · 7H₂O. Pre-mordanting was performed at LR 1:30, at 50 °C for 30 min with mordant concentration of 3 % over the weight of fabric (owf). After mordanting, fabrics were rinsed with cold water and squeezed well.

2.3. Natural dye extraction

As herbal source for biological pigment extraction, the waste onion skin was used. The natural dye was extracted by boiling the 46 g of herbal source in 5 l of distilled water (pH 6.83), at 100 °C for 1 h. After leaving the solution at ambient temperature for 15 h, the solution was filtered and diluted with distilled water in ration 1:1.

2.4. Dyeing Process

Linen fabric was dyed in water extract of natural dye onion skin origin by exhaustion method with LR 1:30, at 95 °C for 60 min. Dyeing was performed before and after pre-bleaching process and with and without mordanting process. After dyeing process, the fabrics were thoroughly washed in cold water followed by hot soaping and cold wash.

2.5. Colouration analysis

Colour characteristics evaluations of dyed samples have been obtained subjectively and objectively by spectrophotometric measurement using a remission spectrophotometer DataColor Spectra Flash 600 PLUS – CT (with constant instrument aperture, D65, using d/8° geometry). The results are presented numerically as L*, C*, h* colour parameters values and by placement of obtained samples in a*/b* colour space according to CIEL*a*b* system. The Kubelka-Munk coefficient (K/S) as the definition of colour efficiency (colour depth) was calculated in terms of K/S values using the Kubelka-Munk equation:

$$K/S = (1 - R)^2/2R \quad (1)$$

where K is the absorption coefficient, S is the scattering coefficient, and R is the reflectance of the dyed fabric.

3. Results and discussion

In paragraph 3.1. and 3.2 subjectively and objectively evaluation of colour characteristics is shown. It can be seen that the subjective experience of colour is much more colourful than objective evaluation. The reason for this is that the total colour appearance is defined by specific relationship of hue (h), lightness (L*) and chroma (C*).

3.1 Subjectively analysis of dyed samples

Pre-treatment of the linen fabric with various metal salts and dyeing process resulted in a wide range of colour hues: dirty pink (without mordant), yellow-brown (Al), red-brown (Cu) to dark brown (Fe) (Figure 3). The fabric pre-bleaching resulted with more vivid and brilliant colour (Figure 4).

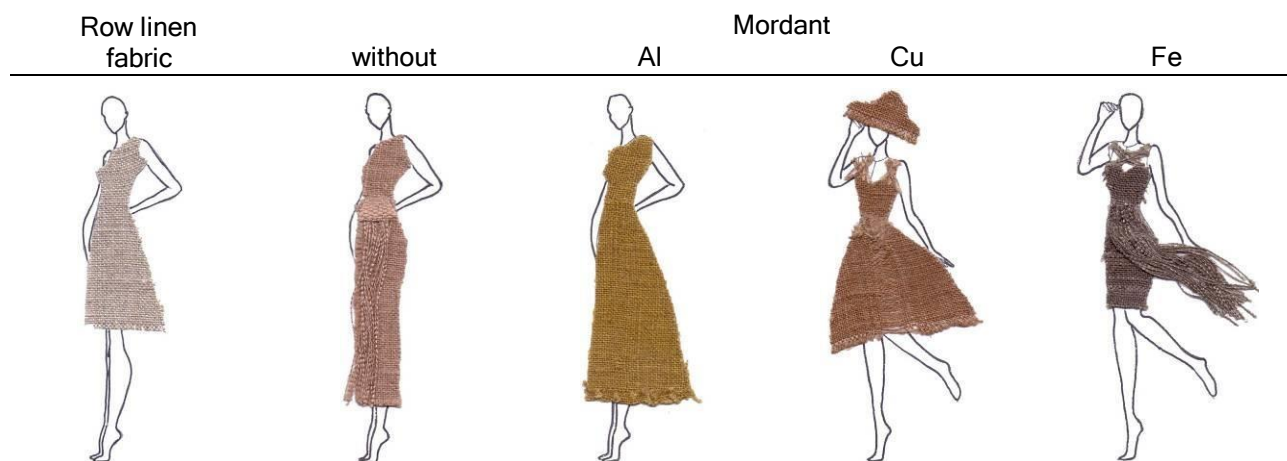

Figure 3: Row linen fabric dyed with natural dye extracted from waste onion skin with and without mordants

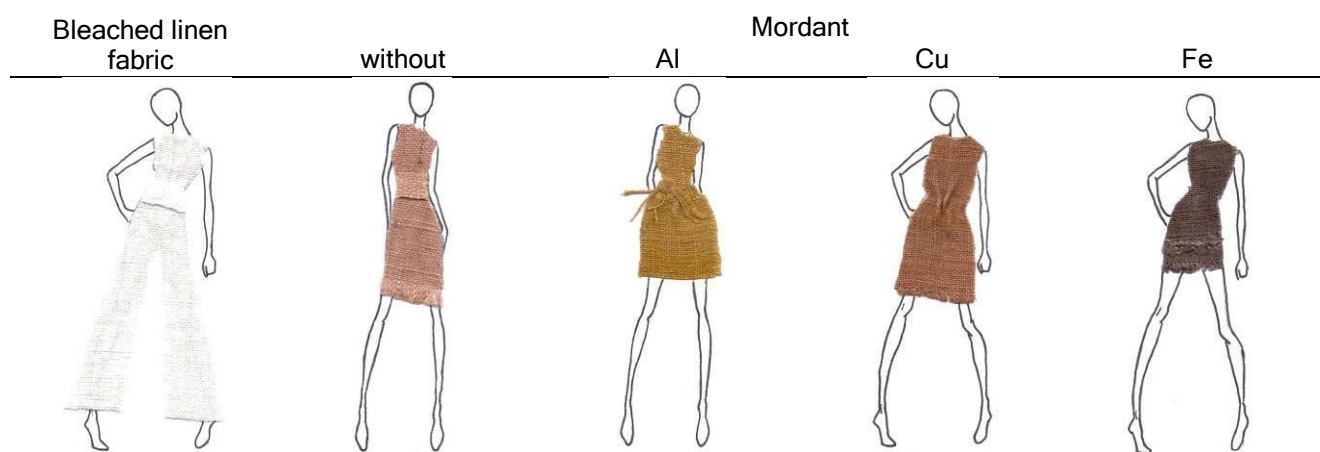

Figure 4: Pre-bleached linen fabric dyed with natural dye extracted from waste onion skin with and without mordants

3.2 Objectively analysis of dyed samples

Figures 5-7 show objective analysis of linen fabric according to CIEL*a*b* system and through Kubelka-Munk coefficient. As expected, the pre-bleaching process does not significantly affect the chromaticity value (C*) of linen fabric (Sample B). However, all dyed pre-bleached samples show an increase of chromaticity (Fig. 6a.), indicating better dye exhaustion due to cleaning of natural linen impurities. On the other hand, increasing of the lightness value (L*) is more characteristic of just white sample (B) than dyed samples (Fig. 6b.). Colour hue analysis show that all values are in the yellow hue area $h = 66.62-81.84$ regardless of the pre-bleaching process (Fig. 5c.). It can be said that the hue value obtained without mordant addition approximately 40, with Al approximately 80, Cu approximately 65 and with Fe addition approximately 82. Obviously, experience of colouration is the result of synergy of all CIEL*a*b* parameters e.g. with aluminium salt, the samples are subjectively yellow-brown, but the hue value is approximately the same as when iron was using, however the

using of Al results in lightness around 50 and the highest chromaticity value between 35 and 42. The use of copper produces reddish tones as shown by the lowest value of colour hues, lightness in the middle of the measuring range and chromaticity around 25. The lowermost lightness shows Fe 29.92 (raw) and 35.83 (bleached) while the chromaticity value for the same samples is 9.32 and 12.59. For this reason, the samples dyed using iron as a mordant are dark brown although h is approximately 82.

The complexity of evaluating the coloration of textiles dyed with natural dyes is confirmed by the Kubelka-Munk coefficient analysis (K/S). The K/S coefficient as the definition of colour efficiency is shown over the entire visible part of the spectrum from 400 to 700 nm for samples dyed before (Figure 7a.) and after (Figure 7b.) pre-bleaching. For the samples obtained without mordants and with Cu it is evident that the pre-bleaching process has no effect. A more significant effect of bleaching is observed in the use of Fe and most of all with Al. Also, by comparing the K/S curves in the visible part of the spectrum, it can be seen that there are no expressed peaks but the values are higher from 400 to 450 nm, which is correlated with the colour hue values in the first quadrant (Figure 5c.). In addition to Al, the peak at 400 nm and the high K/S value coincide with subjective evaluation and objective CIEL*a*b* values.

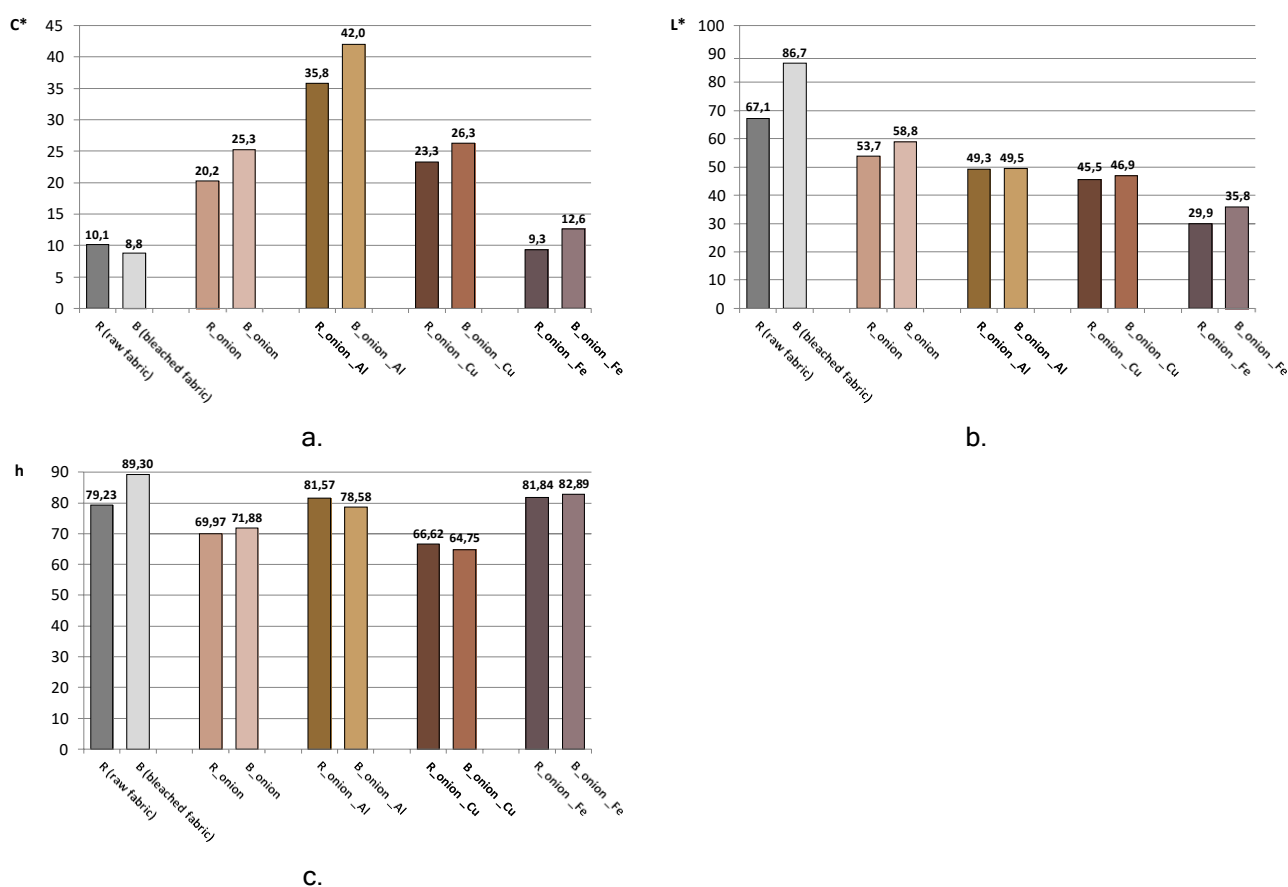

Figure 5: Effect of pre-treatment process and mordants addition on the a. chromaticity (C*), b. lightness (L*) and c. hue (h) of linen fabric dyed in onion skin extract

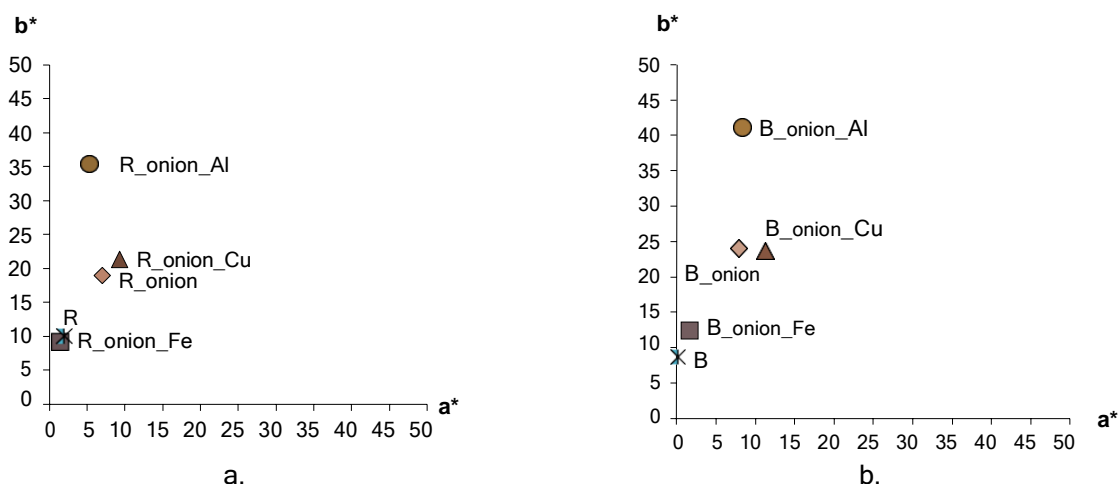

Figure 6: Effect of mordants addition on the colour coordinates of a. raw and b. bleached linen fabric dyed in onion skin extract

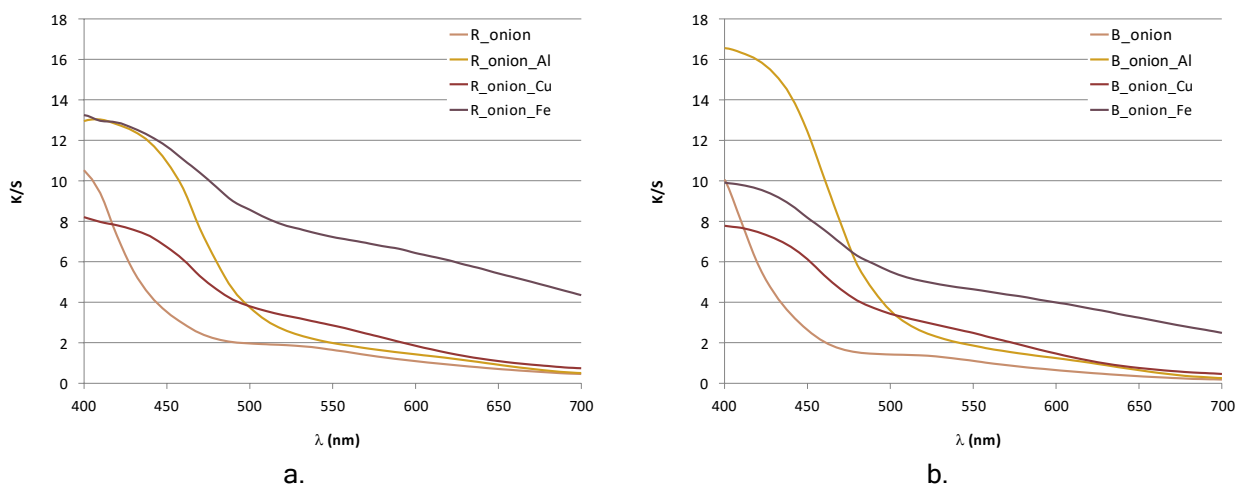

Figure 7: Kubelka-Munk coefficient (K/S) of a. raw and b. bleached linen fabric dyed in onion skin extract

Obtained colorations (Figures 4 to 7) are results of bonds formation between linen fibres and metal ions during mordanting process and between metal ions and natural pigment in dyeing process. Ligand is formed across bonds between hydroxide group on C-6, metal ion and carbonyl groups of flavonoid compounds (Figure 8). The number of cellulose molecules and flavonoid compound in the ligand depends on the valence of the metal ion. All of this, results in the formation of metal complexes of different coloration. Additionally, at the reactivity and coloration of the cellulosic material is also affected by the bleaching process [8, 9].

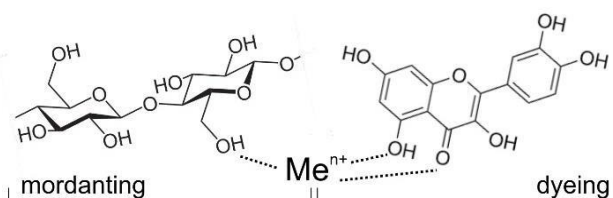

Figure 8: Schematic presentation of ligand formation: linen fibre – metal ion – quercetin

4. Conclusion

In the study, dry onion skins were used for colouring cellulosic flax material (linen fabric). It was an effort to utilize the waste material in an efficient manner at ecological and economical aspect. The source is easy to collect and its dyeing process does not harm the environment. The wide range of colour hues was obtained: greyish (without mordant), yellow-brown (Al), red-brown (Cu) to dark brown (Fe). The subjective colour hue

experience is objectively evaluated by the CIEL*a*b* system. Hue was obtained in the range $h = 66.62 - 81.84$, but the subjective experience is the result of synergy of all parameters (hue, chromaticity and lightness). Process of pre-bleaching does not affect significantly on coloration effect. It can be concluded that this research has found that onion peel has a high potential as source of natural dye for linen fabric. Taking into account such a promising result and a wide spectrum of applications, there is a hope that when, growers, scientists and designers join forces, flax will again enter the global scene.

References

- [1] Rehab, M., et al: Studying the Functional Properties of Linen Fabrics Treated with Microwave and Natural Green Dyes, *International Journal of ChemTech Research*, **7** (2014) 1, 119-130, ISSN 0974-4290.
- [2] Butorac, J., et al: The influence of stages of maturity on the agronomic traits of fibre flax introduced varieties, *Journal of central European agriculture*, **19** (2018) 1; 142-152, ISSN 1332-9049.
- [3] Amutha, K.; Annapoorani, G. S.: Natural dye extraction from agro-waste and its application on textiles, *Asian Dyer*, (2019) 2/3, 35-39, ISSN 0972-9488.
- [4] Liguori, L., et al: Chemical Composition and Antioxidant Properties of Five White Onion (*Allium cepa* L.) Landraces, *Journal of Food Quality*, (2017), 1-9, ISSN 1745-4557.
- [5] Benítez, V., et al: Characterization of Industrial Onion Wastes (*Allium cepa* L.): Dietary Fibre and Bioactive Compounds, *Plant Foods for Human Nutrition*, **66** (2011) 2, 48-57, ISSN 1573-910.
- [6] Sutlović, A., et al: Croatian Traditional Herbal Dyes For Textile Dyeing, *TEDI - International Interdisciplinary Journal of Young Scientists from the Faculty of Textile Technology*, **1** (2011) 1, 65-69, ISSN 1847-9545.
- [7] Tarbuk, A., et al: Ultra-deep black cationized cotton by metal-complex dyeing, *Proceedings of 16th World Textile Conference Autex 2016*, Simončič, B., et al (Ed.), 531-537, ISBN 9789616900171 961690017X, University of Ljubljana, Ljubljana, (2016).
- [8] Trotman, E. R: *Dyeing and Chemical Technology of Textile Fibres*, Charles Griffin & Co LTD, ISBN 0-85264-267-9, London, (1970).
- [9] Zollinger, H.: *Color Chemistry: Syntheses, Properties and Applications of Organic Dyes and Pigments*, VCH, ISBN-13: 978-0895734211, (1987).

Authors:

Ana Maria BOČAK, student
University of Zagreb Faculty of Textile Technology
Prilaz baruna Filipovića 28a, 10000 Zagreb, Croatia
Phone: +385 99 8143450

E-mail: ana.maria.bocak@ttf.hr

Assist. prof. Ružica BRUNSEK, Ph. D.
University of Zagreb Faculty of Textile Technology
Prilaz baruna Filipovića 28a, 10000 Zagreb, Croatia
Phone: +385 91 2538659

E-mail: ruzica.brunsek@ttf.unizg.hr

Assoc. prof. Anita TARBUK, Ph. D.
University of Zagreb Faculty of Textile Technology
Prilaz baruna Filipovića 28a, 10000 Zagreb, Croatia
Phone: +385 91 5067859

E-mail: anita.tarbuk@ttf.unizg.hr

Assoc. prof. Ana SUTLOVIĆ, Ph. D. (corresponding author)
University of Zagreb Faculty of Textile Technology
Prilaz baruna Filipovića 28a, 10000 Zagreb, Croatia
Phone: +385 91 5470271

E-mail: ana.sutlovic@ttf.unizg.hr



REVIEW PAPERS

POTENTIAL OF HEMP TEXTILE FABRICS IN TERMS OF COMFORT

Snežana STANKOVIĆ; Mateja BIZJAK; Dušan POPOVIĆ & Goran POPARIĆ

Abstract: *Traditional applications of hemp fibre for textile products include technical products like ropes and packaging materials, and clothing textile. Modern production offers high added-value products for specific uses such as geotextiles, thermal and acoustic insulation products, filters and composites, and for high-quality clothing sector. Hemp fibres provide high moisture permeability, good thermal and electrical properties, ultraviolet light blocking, anti-microbial and anti-static properties, which is a predisposition to obtain physiologically-friendly textiles. However, there are some limitations of hemp fibre such as low elasticity and low flexibility due to which hemp textile fabrics are characterized by reduced softness and rough handle. These are constraints for wider applications of hemp fabrics as highly comfortable clothing textiles. In this respect, some investigations of comfort properties (both thermal and tactile comfort) properties of a range of hemp based textile materials have been conducted in order to improve their comfort performances. A short review of these investigations is given in this paper.*

Keywords: *Hemp, thermal comfort, tactile comfort, textile fabric, yarn.*

1. Introduction

Hemp is naturally one of the most ecologically friendly fibres and the oldest as well. Hemp is known to have been grown for more than 12000 years, and the oldest hemp fabric discovered dating back to approximately 8000 BC. According to Food and Agriculture Organization (FAO), almost half of the world's industrial hemp supply is grown in China. The production of hemp fibres is characterized by sharp ups and downs, from being extensively used to their decline in the 20th century after World War II mainly because of the presence of psychoactive components (delta9-tetrahydrocannabinol, THC) in hemp. However, by explaining the mistakes made in understanding hemp, since industrial hemp produces less than 0.2% THC and cannot be used as a narcotic, it is being reintroduced in the early 1980s as a renewable source of healthy and environmentally friendly fibres mainly from ecological concerns and future resource balance [1]. Nowadays, cotton has an important share of more than 34% in world textile fibre consumption [2]. However, from the sustainability aspect, the drawbacks of common cotton cultivation are associated with high water consumption and substantial requirements for pesticides and fertilizers [3]. Sustainable potential of hemp is reflected through the benefits such as easy adoption to different climatic conditions, no requirements for pesticides and herbicides, and modest requirements for fertilizer [4]. Hemp is very competitive to weeds and can improve the soil structure. In addition, hemp has bioremediation ability (remove heavy metals from the soil) – restoration of unproductive land into agricultural use with no detrimental effect on the quantity and quality of the crop [5]. A life cycle comparison of water and energy inputs for various hemp and cotton production systems indicated that hemp had a lower impact in respect to energy, water and ecology [6]. Hemp fibres provide the outstanding hygienic (high absorbent and hygroscopic, bacteriostatic), anti-static and anti-microbial properties, good thermal and electric properties, UVR blocking and anti-allergic performance which make hemp fabrics very desirable for use in textile sector for the development of healthy and comfortable textiles. On the other hand, hemp fibres have some limitations concerned with the tactile comfort due to low elasticity and low flexibility, due to which hemp fabrics have reduced softness and rough handle [7,8]. In addition, hemp textiles are easy creasing with poor recovery. Therefore, to provide hemp textile-users with highest level of comfort and aesthetics and to compete in the tough global market place, some comfort properties of hemp textiles have to be improved to match those of traditionally comfort materials. The scientists' efforts go in two directions, one of which is chemical approach to improving softness of hemp textiles. The other more sustainable approach to the production of comfort hemp textiles has been involved in some studies in which the comfort properties has improved by using exclusively mechanical processing operations. A short review of these investigations is given in this paper.

2. Comfort

Clothing is an integral part of human life, and therefore clothing comfort is a universal need of a human being. Comfort is a very complex subject and is very difficult to define. According to Slater [9], comfort is a pleasant state of physiological, psychological, neurophysiological and physical harmony between a human being and the environment. In general, comfort can be divided into three main components – psychological, thermal and

tactile comfort. Physiological comfort is mainly related to the latest fashion trends and acceptability in the society, and does not have much to do with the properties of textile fabrics. Thermal comfort relates to the ability of the clothing materials to support the thermoregulation system of the body to keep its thermal balance and to ensure that the heat loss, skin temperature, air movement and humidity at the body surface produce a pleasant sensation. The key properties of clothing materials by which they influence thermal comfort are transport properties: thermal properties, water vapour permeability, and air permeability. Tactile comfort relates to the mechanical interaction between clothing material and human body. The governing properties of clothing materials by which they influence tactile sensations are deformation behaviour during their stretching, bending, shearing, compression, and so on. Since the load (accompanying deformation of clothing material) transmits to the body at skin-fabric contact areas, the surface characteristics of clothing materials are also very important for tactile sensory perception.

2.1 Chemical approach to comfort improvement of hemp based textiles

With regard to the stiff hand-feel of hemp fibres, research has mainly focused on the use of various treatments to reduce the amount of noncellulosic impurities and to process technical fibres to thinner single fibres so as to increase the softness and spinnability of hemp fibres. One of the traditional methods, chemical treatment of hemp fibres, is still in use. For example, sodium hydroxide has been used to effectively refine hemp fibres up to 12 times in relation to unmodified ones [10]. In addition, hemp fibre flexibility and to some extent, tensile properties were improved [11]. Liu et al. [12] have shown that the suitable treatment with sodium hydroxide solution slenderize and dramatically soften hemp fibres. The investigation conducted by Pejic et al. [13] indicated that when the content of either hemicelluloses or lignin is reduced by chemical treatment with sodium hydroxide or sodium chlorite, the wicking properties of hemp fibres are improved (capillary height is increased up to 2.7 times). Various investigations have confirmed that the liquid ammonia treatment method reduces the crystallinity and degree of orientation of the fibres by which wettability of hemp fibres is improved. As a result of the decrease in crystallinity, the Young's modulus also decreases improving softness of hemp fibres [14].

Zhang and Zhang [15] proposed the treatment with chitosan and epoxy modified silicone oil to improve softness of hemp fabrics. There are few investigations aimed at improving softness, flexibility and crease recovery of hemp fabrics by liquid ammonia treatment. Ammonia penetrates cellulose relatively easily and reacts with the hydroxyl group after breaking hydrogen bonds imparting wrinkle recovery and soft hand to hemp fabric. Li et al. [16] showed in their investigation that the crease recovery and bending modulus was improved by liquid ammonia treatment followed by crosslink finishing. The improved crease recovery of hemp woven fabrics treated liquid ammonia (L/A) was also confirmed by Hwang and Ji [17]. They also indicated the decrease in washing shrinkage of the treated hemp fabrics. Ji and Lee investigated the effect of liquid ammonia treatment on the mechanical and hand properties of hemp woven fabrics by using KES-FB (Kawabata Evaluation System for Fabrics), and found that tensile energy and tensile resilience increased by the L/A treatment [18]. Compression linearity and compression energy decreased while compression resilience increased after the L/A treatment. The values of bending and shearing parameters (bending and shearing rigidity, bending moment, shear hysteresis) for L/A treated hemp woven fabrics increased in relation to the untreated counterparts. Therefore, they concluded that L/A treatment can be an effective way of improving the flexibility and softness of hemp woven fabrics.

When physical activity level or environmental conditions change, the human skin produces liquid perspiration which should be transported away from the skin surface, so that the next-to-skin fabric feels dry enabling the wearer's comfort perception. Lee and Ji [19] evaluated liquid moisture management properties of hemp woven fabrics treated with liquid ammonia and concluded that all the liquid moisture management parameters, such as wetting time, absorption rate, maximum wetted radius, spreading speed and one-way transport capability, of the L/A treated hemp fabrics was improved by the treatment. In addition, the liquid ammonia treatment of hemp woven fabrics caused the wicking speed and drying ratio to be higher compared with the untreated ones [17]. Li et al. [16] have also showed in their investigation that the L/A treatment improve water vapor and air permeability of hemp fabrics.

2.2 Engineering approach to comfort improvement of hemp based textiles

Increased environmental awareness and sustainable concerns inspire the scientists to efforts to improve the tactile comfort of hemp textiles by using exclusively mechanical processing operations. A lot of work has been done to produce hemp-based fabrics by mixing with cotton and wool in order to compensate for hemp limitations in terms of tactile comfort.

In spinning sector, blended yarns can be produced as a mixture of different fibres in the blow room following the steps of carding, drawing, roving and spinning or by the combination of different fibre containing slivers in

the drawing stage of the yarn spinning. However, the main disadvantage of these methods is the need for the same length of both types of fibres; otherwise the longer fibres will be broken worsening the yarn quality. This means that hemp fibres have to be adequately processed as cotton-like or wool-like fibre so as to be able to be processed on cotton or wool spinning systems [20]. To avoid this, Kim and Kim [21] utilized nonconventional (air vortex and siro-spun) spinning methods for producing hemp/tencel yarns (blending ratio 30%/70%) and knitted fabrics with enhanced tactile comfort. They showed that the knitted fabric made from air vortex hemp/tencel yarn is high compressible and extensible with low bending rigidity which gave it a softer tactile hand property as compared to ring- and siro-spun yarn knitted fabrics. In such a way, the application possibility of hemp fibres on the air vortex spinning system was confirmed. To improve the softness of hemp knitted fabrics, Stankovic [22] introduced acrylic yarn along with hemp component into knitted fabric. Not only did the compressibility of the hemp/acrylic knitted fabric increase as compared to the hemp counterpart, but also even more improved after a period of usage the knit. In addition, it has been shown in more recent investigation [23], that the introduction of acrylic yarn does not deteriorate seriously the thermal properties of the knitted fabrics or even improved some of them (thermal diffusivity). Stankovic [24] designed the novel hemp/filament hybrid yarns which were produced by folding hemp single yarn with viscose or polyamide textured (Tactel®) filament in order to produce knitted fabrics with improved compressibility. The results obtained indicated that monofilament accommodation into textured filament component provided a high bulk structure with a large content of air space which contributed to higher compressibility of the knitted fabrics. Stankovic and Bizjak [25] examined the possibility of improving the tactile properties of hemp knitted fabrics by yarn folding. Some of the results are given in Table 1. More extensible and flexible textile fabric characterizes by high extensibility (EMT), and lower value of the linearity of load-extension curve (LT). According to the parameters: compressibility (EMC), compression energy (WC) and compression linearity (LC), the knitted fabric produced from two-folded hemp yarn was characterized by higher softness as compared to that produced from two assembled hemp yarn. Better retention ability was confirmed by the greater value of the compression resilience (RC). The shear deformation of the two-folded hemp yarn knitted fabric was generally unchanged despite higher resistance to shear deformation in wale direction (1.14 N/m and 1.56 N/m for two assembled and two-folded hemp yarn, respectively). The lower the sear hysteresis (2HG and 2HG5), the better the recovery from shear deformation. Some differences in the values of these parameters in the wale and course directions were noticed between the two assembled and two-folded hemp knits [25], but there was no statistically proven difference in averaged shear hysteresis parameters (Table 1). The KES parameters for the surface roughness (MIU, MMD and SMD) indicated an improvement in the surface properties of the two-folded hemp knitted fabric. In addition to the smoother surface of the two-assembled hemp knit, MIU parameter indicated its improved uniformity which resulted from improved uniformity of the two-folded yarn [25].

Table 1. Compression and tensile properties of the plain hemp knitted fabrics [25]

Parameter, unit		Hemp+hemp (two assembled yarn)	Hemp/hemp (two-folded yarn)	p- value ($\alpha=0.05$)
Compression	WC, Nm/m ² (SD)	0.505 (0.031)	0.608 (0.021)	0.008*
	EMC, % (SD)	0.462 (0.043)	0.488 (0.054)	0.016*
	RC, % (SD)	31.48 (6.68)	32.29 (6.67)	0.889
	LC (SD)	0.310 (0.08)	0.280 (0.06)	0.755
Tensile	WT, Nm/m ² (SD)	15.29 (2.85)	15.39 (1.82)	0.971
	EMT, % (SD)	9.51 (0.40)	10.07 (0.14)	0.656
	RT, % (SD)	31.75 (6.15)	30.59 (4.57)	0.836
	LT (SD)	0.656 (0.001)	0.624 (0.001)	0.000*
Shear	G, N/m (SD)	1.43 (0.74)	1.50 (0.09)	0.554
	2HG, N/m (SD)	5.56 (0.86)	5.9 (0.91)	0.672
	2HG5, N/m (SD)	6.19 (0.31)	6.43 (0.77)	0.643
Surface properties	MIU (SD)	0.224 (0.024)	0.211 (0.009)	0.424
	MMD (SD)	0.0303 (0.003)	0.0240 (0.004)	0.032
	SMD, μ m (SD)	16.728 (1.022)	17.690 (0.542)	0.223

* - statistically significant ($p<0.05$)

As a consequence of the changes in internal structure of the complex yarn obtained by folding technique, the geometry of the knitted fabric can be expected. Indeed, due to different yarn aggregation into knitted fabrics, which in turn was a consequence of yarns' flexibility, different pore distributions in the knits were noticed (Figure 1) [25]. Therefore, the thermal comfort parameters were also investigated in the study. The results indicated that the air and water vapour permeability of the knitted fabric produced from two-folded hemp yarn were improved, whereas the increase in thermal resistance was not statistically proved. According to the results, it

seems that folding technique can be an effective technique for improving comfort properties of hemp based textiles.

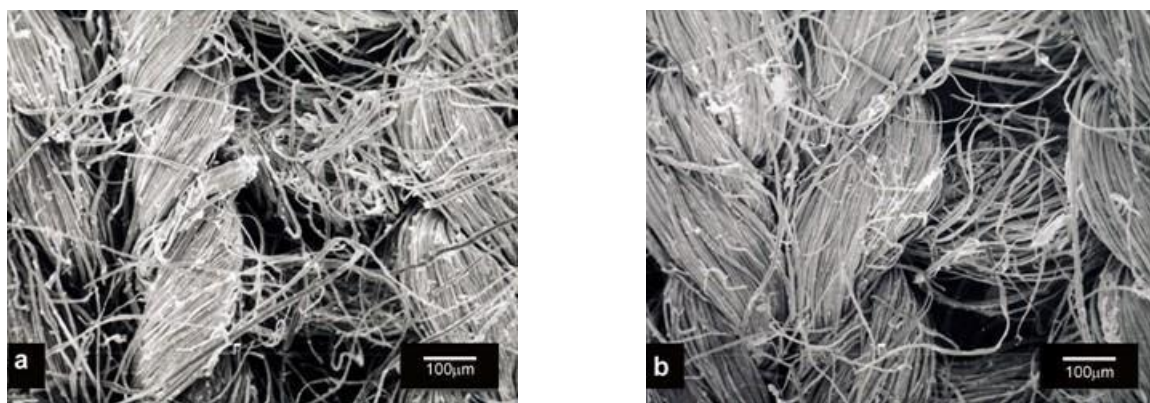

Figure 1: Geometry of the knitted fabrics made from two assembled hemp yarn (a); and two-folded hemp yarn (b) [25]

In an attempt to avoid additional chemical treatments of hemp textile fabrics, but also to exclude additional mechanical operation (such as folding of yarns) to design comfort performances, the blends of hemp with other textile fibres has been formed by assembling (with no twist) homogeneous (one-fibre type) yarns. The results of the thermal properties of hemp based knitted fabrics blended (by assembling yarns) with traditional comfort fibres such as cotton and viscose indicated the trend towards increasing thermal conductivity and overall heat transfer coefficient [26]. According to investigation conducted by Stankovic et al. [27], transient thermal response was also confirmed to be manageable by introducing other cellulose fibres. The knitted fabrics were produced under the same machine settings by combining two same or different fibre content yarns (with the same linear density and twist level), and therefore they had comparable basic characteristics such as surface density, stitch density, thickness) [27]. It has been shown that the combination of the hemp yarn with the cotton or viscose component have the positive effect on thermal diffusivity of the knitted fabrics, which is very important bearing in mind that a higher value of this parameter indicates that the thermal balance will be reached more quickly. Increase in thermal diffusivity of the hemp/cotton and hemp/viscose knits resulted from higher thermal conductivity and specific heat, and lower bulk density of these knits as compared to the hemp knit (Table 2) [26,27]. The trend towards an increase in thermal absorptivity has been noticed which means that the feeling become cooler in touch with the blended fabrics due to their higher thermal conductivity and heat capacity (Table 2). In addition to the transient thermal properties of the hemp based knitted fabrics, a research indicated that the liquid transfer ability of hemp based knits can be improved by incorporating synthetic (acrylic) yarn [28].

Table 2: Physical properties of the knitted fabrics [26,27]

Fibre	Bulk density, kg/m ³	Porosity, %	Specific heat capacity, J/gK
Hemp	398.47	74.0	0.75
Cotton	326.74	78.2	1.35
Viscose	353.05	76.5	1.08
Hemp/cotton	353.40	76.4	1.18
Hemp/viscose	386.62	74.2	0.97

Stankovic et al. [29] proposed the modification of hemp based textile materials by using the twist intensity of the yarn as a design tool for quality comfort performances. They showed that not only the transport properties (air and water vapour permeability, thermal resistance) changed by the introduction of cotton component, but also that the extent to which these properties were changed was dependent on the twist intensity of the cotton yarn (Figure 2). Novakovic et al. [30] evaluated both steady-state and transient properties of the hemp and hemp/acrylic knitted fabrics before and after the trial period (wear and care cycles), and indicated that changes in geometry of these knits, which was affected by increased yarn aggregation in the knits after the wear trial test, positively influenced their thermal transfer properties.

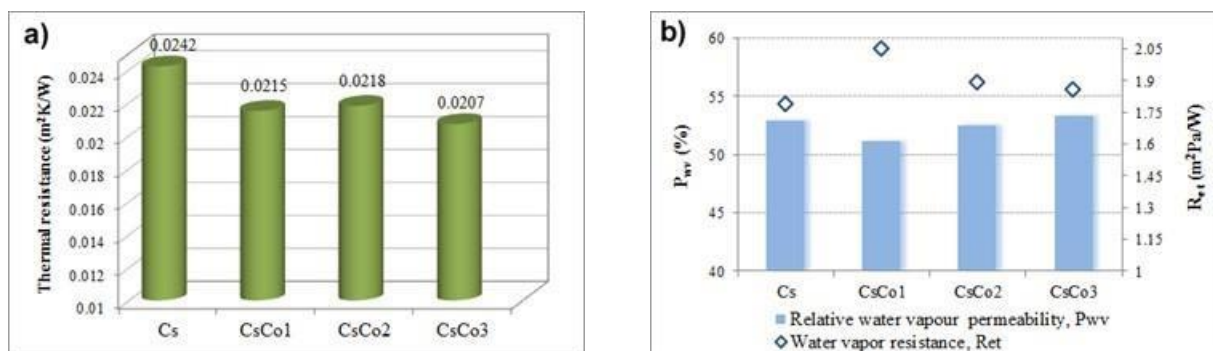

Figure 2: Thermal resistance (a) and water vapour permeability (b) of the hemp based knitted fabrics: Cs-hemp; Co1- min twisted cotton yarn; Co2-medium twisted cotton yarn; Co3-max twisted cotton yarn [29]

3. Conclusion

The potential of hemp as an attractive multifunctional crop is confirmed nowadays on the global market with more than 25000 hemp products in a considerable number of industry sectors such as paper, packaging, automotive, bioenergy, building, textile, food and pharmaceutical industry. In textile sector, modern production offers high added-value products such as textile composites, filters and, last but not least, high-quality clothing sector. This short review presents the established knowledge and guidelines for an adequate hemp textiles product design, and how textile engineers can make use of available technologies to optimize transport and deformation properties of hemp based textile materials in order to improve thermal and tactile comfort performances. There is no doubt that the current knowledge is just the beginning and a good basis for further research in improving comfort of hemp based textiles.

References

- [1] Van der Werf, H.M.G.: Life cycle analysis of filed production of fibre hemp, the effect of production practices on environmental impacts. *Euphytica*, **Vol.** 140 (2004), pp.13-23, ISSN 0014-2336
- [2] Islam, S.; et al.: Perspectives for natural product based agents derived from industrial plants in textile applications - a review, *J. Cleaner Prod.*, **Vol.** 57 (2013) pp. 2-18, ISSN 0959-6526
- [3] Ullah, A.; et al.: Eco-efficiency of cotton-cropping systems in Pakistan: an integrated approach of life cycle assessment and data envelopment analysis. *J. Cleaner Prod.* **Vol.** 134 (2016) pp. 623-632, ISSN 0959-6526
- [4] Ranalli, P. & Venturi, G.: Hemp as a raw material for industrial applications, *Euphytica*, **Vol.** 140 (2004) pp. 1-6, ISSN 0014-2336
- [5] Kozłowski, R.; et al.: Microbial processes in the degradation of fibres, In *Biodegradable and sustainable fibres*. Woodhead Publishing Ltd., ISBN-10: 1-84569-099-0, Cambridge, (2005), pp. 36-88
- [6] Cherrett, N.; et al.: Ecological footprint and water analysis of cotton, hemp and polyester. Report prepared for and reviewed by BioRegional Development Group and WWF Cymru. Available from <https://mediamanager.sei.org/documents/Publications/SEI-Report-EcologicalFootprintAndWaterAnalysisOfCottonHempAndPolyester-2005.pdf> Accessed: 2019-10-15
- [7] Asad, R.A.M.; et al.: Characterization of prickly tactile discomfort properties of different textile single fibers using an axial fiber-compression-bending analyzer (FICBA). *Text. Res. J.*, **Vol.** 85 (2015) No. 5, pp. 512-523, ISSN 0040-5175
- [8] Stankovic, S.: Compression hysteresis of fibrous systems, *Polym. Eng. Sci.*, **Vol.** 48 (2008) pp. 676-682, ISSN 0032-3888
- [9] Slater K.: Discussion paper the assessment of comfort, *J. Text. Inst.*, **Vol.** 77 (1986), pp. 151-171, ISSN 0040-5000
- [10] Kostic, M.; et al.: Effect of hemicelluloses and lignin on the sorption and electrical properties of hemp fibers, *Ind. Crop Prod.*, **Vol.** 32 (2010) pp.169-174, ISSN 0926-6690
- [11] Kostic, M.; et al.: Quality of chemically modified hemp fibers, *Bioresour. Technol.*, **Vol.** 99 (2008) No.1, pp. 94-99, ISSN 0960-8524
- [12] Liu, H.; et al.: Influence of alkali treatment on the structure and properties of hemp fibers, *Fibre. Polym.*, **Vol.** 14 (2013) pp. 389-395, ISSN 1229-9197
- [13] Pejic, B., et al.: The effect of hemicellulose and lignin removal on water uptake behaviour of hemp fibers, *Bioresour. Technol.*, **Vol.** 99 (2008) No.15, pp. 7152-7159, ISSN 0960-8524

- [14] Zhang, J.; et al.: Evaluation of liquid ammonia treatment on surface characteristics of hemp fiber, *Celulose*, **Vol.** 21 (2014) pp. 569-579, ISSN 0969-0239
- [15] Zhang, G. & Zhang, L.M.: 2010. Improving the dyeing properties and softness of hemp fabric using chitosan and epoxy modified silicone oil, *J. Text. Inst.* **Vol.** 101 (2012) No.9, pp. 849-857, ISSN 0040-5000
- [16] Li, J.; et al.: Wear properties of hemp, ramie and linen fabrics after liquid ammonia/crosslinking treatment, *Fibres and Textiles in Eastern Europe*, **Vol.** 18 (2010) No.5, pp. 81-85, ISSN 1230-3666
- [17] Hwang, M. S.; & Ji, D.S.: The effect of yarn number and liquid ammonia treatment on the physical properties of hemp woven fabrics, *Fibre. Polym.*, **Vol.** 13 (2012) pp.1335-1340, ISSN 1229-9197
- [18] Ji, D.S. & Lee, J.J.: Mechanical properties and hand evaluation of hemp woven fabrics treated with liquid ammonia, *Fibre. Polym.*, **Vol.** 17 (2016) pp. 143-150, ISSN 1229-9197
- [19] Lee, J.J. & Ji, D.S.: Evaluation of liquid moisture management properties on hemp woven fabrics treated with liquid ammonia, *Text. Res. J.*, **Vol.** 87 (2017) pp.1752-1764, ISSN 0040-5175
- [20] Cierpucha, W.; et al.: Applicability of flax and hemp as raw materials for production of cotton-like fibres and blended yarn in Poland, *Fibres and Textiles in Eastern Europe*, **Vol.** 12 (2004) No.3, pp. 13-18, ISSN 1230-3666
- [21] Kim, H.A. & Kim, S.J.: 2018. Hand and wear comfort of knitted fabrics made of hemp/tencel yarns applicable to garment. *Fibre. Polym.* **Vol.** 19 (2018) No.7, pp.1539-1547, ISSN 1229-9197
- [22] Stankovic, S.: Compressional behaviour of knitted fabrics exposed to repeated wash and wear cycles, *Hem.Ind.*, **Vol.** 62 (2006) No. 5-6, pp. 129-137, ISSN 0367-598X
- [23] Novakovic, et al.: Dry heat transfer characteristics of hemp based knitted fabrics, Proceedings of 15th Autex World Textile Conference, ISBN 978-609-685-276-0, Romania, June 10-12, Bucharest, (2015)
- [24] Stankovic, S.: Static lateral compression of hemp/filament hybrid yarn knitted fabrics, *Fibre. Polym.*, **Vol.** 9 (2008) No.2, pp.187-193, ISSN 1229-9197
- [25] Stankovic, S. & Bizjak, M.: Effect of yarn folding on comfort properties of hemp knitted fabrics, *Cloth. Text. Res. J.*, **Vol.** 32 (2014) No. 3, pp. 202-214, ISSN 0887-302X
- [26] Stankovic, et al.: Thermal properties of textile fabrics made of natural and regenerated cellulose fabrics, *Polymer Testing*, **Vol.** 27 (2008) pp. 41-48, ISSN 0142-9418
- [27] Stankovic, et al.: Transient thermal response of textile fabrics made of natural and regenerated cellulose fibers, *Polymer Testing*, **Vol.** 34 (2014) pp. 97-102, ISSN 0142-9418
- [28] Novakovic, et al.: Liquid transfer properties of textile fabrics as a function of moisture content, *Hem. Ind.* **Vol.** 74 (2020) No.2, pp. 119-132, ISSN 0367-598X
- [29] Stankovic, et al.: Novel engineering approach to optimization of thermal comfort properties of hemp containing textiles, *J. Text. Inst.* **Vol.** 110 (2019) No.9, pp. 1271-1279, ISSN 0040-5000
- [30] Novakovic, et al.: Development of comfortable and eco-friendly cellulose based textiles with improved sustainability, *J.Clean. Prod.* **Vol.** 267 (2020) 122154, ISSN 0959-6526

Authors:

Prof. Dr Snežana STANKOVIĆ (corresponding author)
Faculty of Technology and Metallurgy, University of Belgrade
Karnegijeva 4, 11000 Belgrade, Serbia
Phone: +(381) (11) 3303 857

Fax: +(381) (11) 3370 387

E-mail: stankovic@tmf.bg.ac.rs

Prof. Dr Mateja BIZJAK
Faculty of Natural Science and Engineering, University of Ljubljana
Snežniška 5, 1000 Ljubljana, Slovenia
Phone: +(386) (1) 200 3219

Fax: +(386) (1) 200 3270

E-mail: mateja.bizjak@ntf.uni-lj.si

Prof. Dr Dušan POPOVIĆ; Prof. Dr Goran POPARIĆ
Faculty of Physics, University of Belgrade
Studentski trg 12, 11000 Belgrade, Serbia
Phone: +(381) (11) 2644 961
Phone: +(381) (11) 630 152

Fax: +(381) (11) 3282 619

Fax: +(381) (11) 3282 619

E-mail: dusan@ff.bg.ac.rs

E-mail: Goran_Poparic@ff.bg.ac.rs

AI FOR FASHION

Edit CSANÁK

Abstract: *Technology and Artificial Intelligence have a significant impact on all aspects of Fashion, from designing to production and consumption. Fashion has always been a forward-looking phenomenon, willing to adopt new technologies as they emerge. Artificial Intelligence is no exception as it moves as fast as Fashion. The AI has been used in analyzing fashion trends and consumer needs for over a decade. Its impact on style and the enhancement of phenomena as Fast Fashion, is indisputable. The clothing industry 4.0 digitalization is increasingly relying on the use of advanced technology, moving towards its 5.0 version, the use of Artificial Intelligence in the broader scope of activities. However, the study of the short career of Artificial Intelligence in Fashion clearly shows that AI has a significant impact on this phenomenon and the related industry, a considerable player of the global economy. The current situation raises numerous questions about one of the primary cultural phenomena. Some fashion professionals question the current unpredictable social, cultural, economic environment evolving the future of fashion. Along with the issue of sustainability, several are addressing the issues raised by the application of artificial intelligence. Thus, the examination of the supposed directions, with the prediction of their wither impact, is essential for the development of creative industries. This article attempts to review the current use of AI in the fashion industry and fashion market. This article is part of a study conducted by the Doctoral School of Security Sciences, the Artificial Intelligence Workshop, and the Product Design Institute of Sándor Rejtő Faculty of Light Industry and Environmental Engineering of the Óbuda University Budapest, Hungary.*

Keywords: *fashion design, digitalization in Fashion, AI, Artificial Intelligence*

1. Introduction

Fashion, which motor is the continuous change and progress, faces new challenges day-by-day. The fashion industry today is one of the leading economies in the World, with an estimated value of up to 3,000 billion US dollars [1,2]. Garment manufacturing, one of the oldest human activities, has come down through the centuries with continuously adapting to technology and society improvements. Striving to keep up with the fast-changing consumer needs, the fashion industry today is rapidly adopting the post-modern, Industry 4.0 and recently 5.0 garment production technologies, along with all the latest digital achievements. The fulfillment of economic, social, and cultural sustainability in a holistic sense is of unquestionable interest to the World today. All the real-time efforts direct towards eliminating the polluting activities and production processes of several well-known harmful industries, such fashion industry is. The number of initiatives and actions taken to reduce the environmental activities of the fashion industry has increased vividly over the last few years. Even the tangible results the players involved still do not seem to be pulling the wagon in one direction. Over the last decade, significant digital innovations have been applied not only in sales and retail but also in digitalization of the entire phase of the clothing supply chain. These are extended to the technologies used in designing. Bodies of fashion and technology experts examine how to integrate the latest technological innovations to fit the demand of revitalization of the fashion industry, extending it to the involvement of the AI. However, when technology and Artificial Intelligence are applied in an uncontrolled way, modern technologies only accelerate the already overburdened economic processes. They may contribute disrupting the sensitive economic system of the fashion industry, and calling into question its cultural, artistic, and aesthetic value.

2. Basics of Artificial Intelligence

Artificial Intelligence (AI), often called machine intelligence, is the kind of Intelligence that machines show. The general purpose of Artificial Intelligence, an academic discipline that was founded in computer science in 1956, is to create technology that enables computers and machines to operate intelligently. According to the current state-of-art, AI is considered *any device that perceives its environment and takes actions that maximize its chance of successfully achieving its goals*. In short, therefore, AI is a machine that can learn and think, and can perform specific tasks independently. The traditional goals of AI research include reasoning, planning, learning, knowledge representation, language processing, perception, and the ability to move and manipulate objects. Further areas of research are Social Intelligence and General Intelligence. A system that recognizes its environment and takes actions that maximize its chances of success is called an **intelligent agent**. Programs that solve specific problems are the most simple intelligent agents. More complex agents can imitate

humans, copy organizations of human beings (for instance, a company), or copy their activities. Intelligence subdivides the general problem into sub-problems. They consist of features or capabilities that researchers expect to see an intelligent system appear. Fields like planning, learning, perception, motion, or manipulation of objects are just some of the featured areas of AI research. **Knowledge representation and reasoning** in the field of Artificial Intelligence (AI) are committed to presenting information in a form that a computer system can use to solve complex tasks. Problems of **reasoning and problem-solving** were solved already during early development; the AI research was able to model the process of reasoning and problem solving (Allen Newell and Herbert A. Simon, 1959).

AI research has developed methods for dealing with uncertain or incomplete information, using the concepts of probability and economics. However, the first algorithms proved inadequate to solve big argument problems since they faced a "combinatorial explosion": when the problems grew more significant, the machines became exponentially slower. Most of their problems are solved with quick, intuitive judgments.

The basis of the programming language is conditional statements, conditional expressions, and conditional constructs. The `if-then` construct (sometimes called `if-then-else`) is common across many programming languages. It is the core boolean condition that a computer can solve. It bases on the intrinsic values that something is `True` or `False`. In contrast, the combination of this expression, the `If` and `Then` surrounding it, and the subsequent consequences, form a conditional statement that has an inner meaning (for example, expresses a coherent logic rule) but has no intrinsic value.

2.1. Algorithms

The processes which enable computers and machines to operate intelligently are **algorithms**. Different processes assigned to the CPU (**C**entral **P**rocessing **U**nit) are based on particular scheduling algorithms. The algorithm is a sequence of steps for a computer program to complete a task. The writing of algorithms is a science within computer science: creating unique algorithms and knowing when and how to apply them are the base of the computer programs which make our everyday life well-processed today. By the use of smartphone applications, we daily use dozens of them while running the videos (audio and video compression algorithms), or finding the best route to our office (route finding algorithms). Optimization and process scheduling algorithms arrange the traffic lights during our travel. These algorithms may be non-preemptive or preemptive.

3. Artificial Intelligence for Fashion in the era of Big Data

By Nassim Nicolas Taleb (in a complex meaning), *Intelligence consists of ignoring irrelevant things*. Artificial Intelligence incorporates a set of methods that are very suitable in the field of Fashion. AI is capable of handling the "3V" of big data, namely speed, variation, quantity with uncertainty, volatility, complexity in the fashion industry, and related markets. However, AI techniques are already in use in all sectors of the fashion industry, the diversity of currently available methods, models, applications, and data types makes implementing these techniques difficult. It scares some fashion companies. The consumer movements, such as sustainable fashion movement, make fashion consumers in their shopping actions to be more increasingly driven by a sense of consciousness rather than greed. Nevertheless, it still can be stated people have never consumed as many clothes as today, and along with it, the way how they do it changed.

3.1. Internet in action: Data mining and fashion sales predicting methods based on AI

The information has become probably the most valuable element for society and industrial progress today. The big data environment has radically transformed our daily life and the economic and business World. For the fashion industry, the Big Data Era, supported by applications of the Internet, is very challenging and poses a considerable scale of opportunities. Many types of data can be analyzed in the context of Fashion: point-of-sale (POS) data, geographic information systems (GIS) data, social media data, virtual 3D data, sensory data, textile physical data. The management of the profitable use of these data requires advanced techniques. Data mining is an interdisciplinary subfield of computer science and statistics, the process of discovering patterns in large data sets involving methods at the intersection of machine learning, statistics, and database systems. The overall goal is to extract information (with intelligent methods) from a data set and transform the information into a comprehensible structure for further use. Data mining is the analysis step of the "knowledge discovery in databases" process or KDD. Before data mining algorithms can be used, a target data set must be assembled. Application of Knowledge Discovery in Databases (KDD) – a form of data mining, roots back to the 1990s, when the term *data mining* appeared first in the database community; these were the years 2005-2006. [3,4].

The success of a collection is a crucial issue for the survival of a fashion brand. To predict the success of fashion products is difficult, as the ever-changing landscape of Fashion shows short life cycles and high volatility of the consumer trends. The foreseeing abilities of the skilled predictors refined in the digital era; the traditional techniques developed, more recently involving the Artificial Intelligence in the Big Data analysis. Several AI methods and AI-based hybrid methods have proven effective in forecasting fashion sales performance. [5] [6] With the increasing demand to be able to follow consumers' demands, the quality and type of information changed. Before companies expected to be told, through valuable reports and trend-books, what to design for their customers in detail, today, designers prefer to rely on comprehensive lifestyle, socio-cultural, and economic trend-analysis building their brand identity alone. Today, fashion industry workers and trend forecasters rely on the Internet to retrieve information; they spend a significant volume of time tracking *what is being looked at online and who is doing the looking*. New technologies are helping retailers to manage inventory using AI-powered tools to gauge demand.

3.1.1. Virtual style assistants and fitting applications

Forecasting is but just one example of using Artificial Intelligence in the fashion industry. According to an article recently published by the Forbes Magazine: "...despite the established nature of the fashion industry, AI is fundamentally transforming the industry from the way that fashion companies manufacture their products to the way they are marketed and sold. AI technologies are transforming the fashion industry in every element of its value chains such as designing, manufacturing, logistics, marketing, and sales." change is coming (whether we like it or not)... Article of the WWD magazine highlights that the *world-leading fashion industry sees AI empowering designers, brands, and retailers to make better products and create more compelling shopping experiences*. [7] AI has reached the fashion industry making the shopping experience of the customers ever comfortable. For example, a virtual DressingRoom app of the clothing giant Gap, introduced in 2018, created to help clients to try on the desired clothing virtually. (Fig 1) [8]

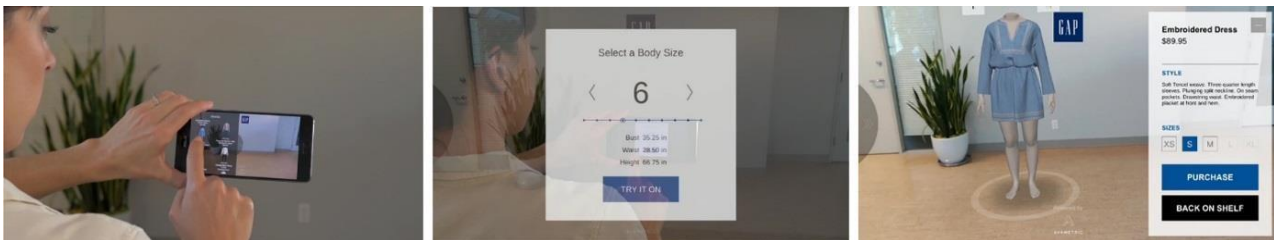

Figure 1: GAP's Virtual DressingRoom visualizes the outfit on one of five body types

Another application example is the Nike Fit, a scanning app that collects data on 13 points on a person's foot to measure the full shape of a user's feet within a matter of seconds, fitting each Nike shoe style using a combination of computer vision, data science, machine learning, Artificial Intelligence, and recommendation algorithms. (Fig 2) [9]

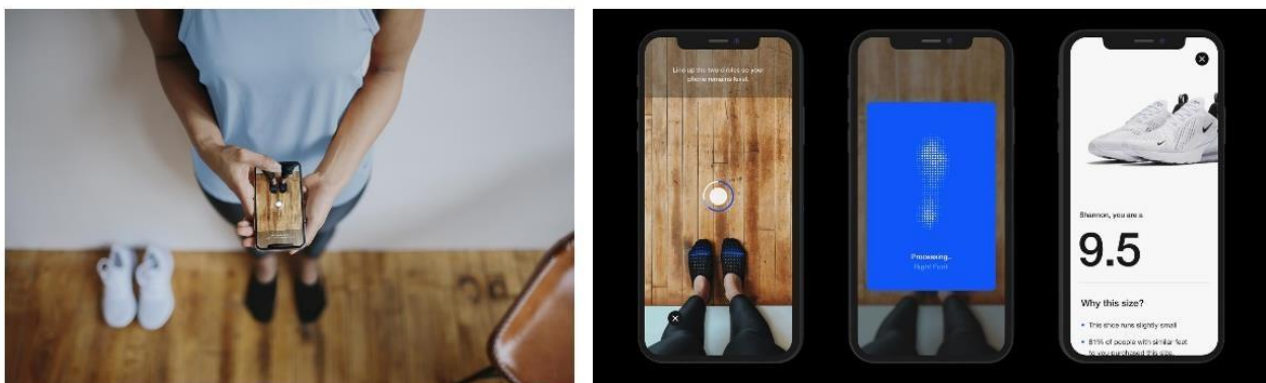

Figure 2: Nike Fit foot scanning application

3.2. AI as a fashion designer

Fashion experts are skeptical about if an industry built on creativity can be ever computerized completely. Fashion, as a materialization of human fantasy concerning the human body, shaping of the silhouette of the outfit, and creation of custom beauty, is eternally an art, an activity addressed to designers and artists. If AI, as augmented Intelligence, can help the human thinking process to focus on higher-value decision-making, arises a logical question: *Can AI become a fashion designer?* The answer is, unfortunately: Yes. The San Francisco based research center of the giant merchandising Amazon was launched the year 2004. Lab126 has developed an algorithm able to recognize particular fashion styles tracing on images; later, the tool can generate similar style new items. A simple, however competitive AI fashion designer (Fig 3).



Figure 3: Amazon's fashion algorithm that can design clothing by analyzing a bunch of images to copy the style and then apply them to new items

AI-enabled improvements are already found in the fashion sector; several forward-thinking retailers are already using social networks (Instagram, Pinterest) to track the latest fashion trends and respond quickly. Processes of the leading companies are powered with smart technologies, enabling higher speed, lower cost, and improved flexibility at each stage of the supply chain, and it has further capacities in production automation and delivery of the goods. It has further capabilities in areas including forecasting, analyzing of new trends choosing and making right and sustainable fabric and color combinations, designing the desired cut with zero waste, organization of the production process in the most flexible, and sustainable way (Fig 3).

4. Highlights of AI in relevance to fashion designing

When discussing prospects of application of Artificial Intelligence in Fashion Designing, firstly, we must highlight: Design is a form of reasoning-argumentation of a solution, a kind of a proposal. The arguments can also be typed according to what logical way we reach the conclusion we formulated in the theorem. Fields and features that receive the most attention in AI research are processes of planning, reasoning, and problem-solving, which also constitute the most complex problems in the design. Design is a form of problem-solving. In a psychological approach, we call a problem any question or task for which we cannot find the exact or immediate answer or the solution. The types of problems and critical phases of the thought process: 1. Findings (diagnosis), 2. Classification (analysis, sorting), 3. Design (goals, solutions). Figure 4, with a range of sweatshirts, illustrates the problem-solving issue and process. (Fig 4)



Figure 4: Range of sweatshirts (left to right): 1. Plain, gray round-neck long sleeve, 2. Decorated, white round-neck long sleeve, 3. Plain, yellow long sleeve hoodie, 4. Decorated, dark gray long sleeve hoodie with zipper

According to the general methodology, the macro-phases of the problem-solving process are the following:

1. Finding - Diagnosis:

- What: is the problem that needs to be solved? (See: To create a sweatshirt.)
- Who: is the general audience who needs to solve the problem? (E.g., for men, women, or children.)

2. Classification - Analysis, sorting, and systematization:

- Vision: What is it? (See, for example, to create a Spring-Summer or Fall-Winter collection.)
- Strategy: How will we do this? (E.g. creating a custom product range for a customer group.)
- Target: Who is the specific target group? (Subdivision; e.g., men, young woman, teenagers, etc.)

3. Design - Defining outcome goals, suggestions for solution:

- Goals: What are do we set? (See: To create sweatshirts, long sleeves, round necks, etc.)
- Suggestions: What exactly are we going to achieve? (For example plain, or decorated, striped, etc.)
- Features: What features does this manifest have? (Round neck, hoodie with zipper, white, etc.)

In the case of a basic sweatshirt (Fig. 5), a problem seems relatively easy to be solved. Arising trend-related features are "easy" to classify stylistically, harder in aesthetical approach! See Figure 5.



Figure 5: Example of decorated long sleeve, round neck sweatshirt

4.1 Knowledge representation: Highlights of fashion designing with machine

A machine a computer program able to reason, and which uses a knowledge base to solve complex problems is called a **knowledge-based system** (KBS). Technical, scientific, and social aspects involved in building, maintaining, and using knowledge-based systems refers to **knowledge engineering** (KE). Artificial intelligence systems imitate complex human decision making. It bases on three types of reasoning: induction, deduction, and abduction. The most challenging problems of knowledge representation are [3]:

1. Default reasoning and the qualification problem, i.e., many of the things people know take the form of "working assumptions." In design, it refers to a matter of the use of *subjective constancies*.

2. The breadth of commonsense knowledge (i.e., knowledge necessary to run an average research project) builds on examination of a vast amount of information. The average person knows a lot of atomic facts. Humanity has accumulated an almost unmanageable amount of clothing-type information during civilization. Organizing this is both a formal and a stylish challenge. See it illustrated with the example collar, which is only one of the (possible) details on the garment (Fig 6).



Figure 6: Collars (left to right) Tudor ruff (Portrait by Michiel Jansz van Miereveldt of Elizabeth Queen of Bohemia 1623) Edwardian collars (around 1911), Historic details from 1911 and 1912, and 1920s Men's Shirts and Collars

Symbolic artificial intelligence is the expression of a collection of all the methods used in the research of artificial intelligence, based on a high-level (symbolic) (human-readable) representation of problems, logic, and research. **3. The subsymbolic form of some commonsense knowledge**, i.e., what people know, is not a fact or statement that they can verbally express. Many of the decisions/expressions are made driven unconscious and sub-symbolic intuitions or tendencies in the human brain. Such knowledge informs, supports, and creates the context of symbolic, conscious knowledge. In terms of design, it features:

- **Designing often bases on a hypothesis (abduction)**, a "violent," a formal conclusion, a kind of "best explanation." The creative mind can reach a proper conclusion without logic, ignoring the rules. The design process is the use of simple logic in a system of visual elements and principles. Any reasonable person will identify similar variables and interactions.
- **Elements of abductive design will make the final result will be different.** These are 1. The designer, 2. The design process (itself), 3. The product to be designed. These elements may vary and are always different due to the approach of the designer, resulting in that the final product will always be different.
- **The process of creative cognition is a somewhat unconscious process, characterized by a high degree of adaptation.** The creative process is a mental process based on the interaction between analysis and imagination, characterized by consciousness, passion, and commitment.
- **Creativity as the implementation of "unexpected coexistence."** To create a new product, we need to have some knowledge, but we must also forget this knowledge to realize the novel, unexpected relationships between things.

5. Challenges on the application of AI in the future fashion design

In the age of digitization, AI and machine learning (ML) based technologies offer manufacturers automated solutions in the fashion industry. Artificial intelligence is currently used in many areas of fashion, and professionals already see the best possible opportunities to exploit it further. AI-compatible machines and robots easily sew fabrics perfectly, while also being able to detect fabric defects and provide quality assurance to ensure that actual design shades match the new colors. Some retail giants, such as Amazon and Walmart, already have their clothing brands and use machine learning systems that identify the venue and, in the not-too-distant future, create fashion trends that customers would rather buy. The AI can detect new trends with reduced (human) forecast error. AI can design to make endless combinations of the variables (see illustrated with Fig. 4, 5, and 6). Changing something will change everything; the many possible connections between design and performance variables result in different performance.

Why is it all so challenging for the future of fashion design? Since the possibility of taste reduction destroying the culture. Application of the intelligent machine to essentially human activities bases today's on fast teaching of existing patterns. Fashion design bases not only on random variations, mixture or custom adaptation of these patterns. If art and design are forms of "*creating beauty and order in function*" (Viktor Papanek), then fashion is continuous redefinition of the function and clothing aesthetics. The Muze project is a pilot collaboration between the European e-commerce site Zalando and Google. It was one of the first "machine learning" projects involved in fashion design. Muze does not assemble products; it only offers ten different basic model versions in different colors and prints, based on "inspirations" given by users (Fig. 7).

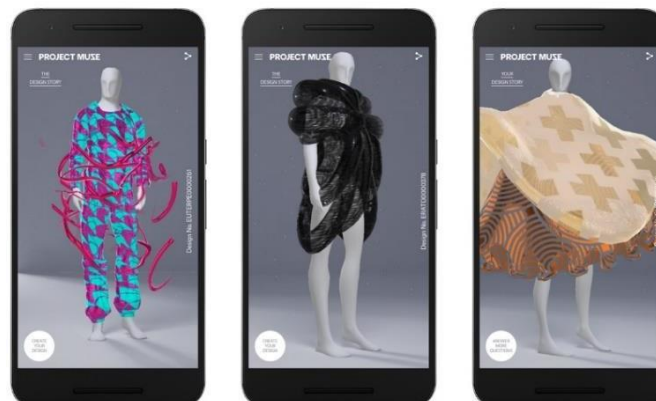

Figure 7: Designs made by algorithm Muse

Algorithm-Driven Design is the new know-how in design; it is about how Artificial Intelligence is changing the design [11].

6. Conclusion

Consumption is rising day by day in the super-powered digital era, more recently, including the involvement of artificial Intelligence. Increased application of Artificial Intelligence in Fashion raises new questions in the aspect of the quality of design and its cultural aspects. Design, which is profoundly a humanistic endeavor, can lose its essential value, which refers to Humanity and Art. The widespread application of digitalization opened endless technological opportunities, supporting retail in the faster speed of the goods to market, what are bad news for Sustainability in Fashion. This article attempted to summarize a handle of facts, which constitute the basis of a recent, prospective collaborative research.

References

- [1] O'Connell L.: Size of the global apparel market in 2015 and 2017, Available from <https://www.statista.com/statistics/279735/global-apparel-market-size-by-region/> Accessed: 12. Nov. 2019.
- [2] FashionUnited, "Global fashion industry statistics - International apparel," [Online]. Available from: <https://fashionunited.com/global-fashion-industry-statistics/#tab2> Accessed: 8. Nov. 2019.
- [3] Russell S. J.; Norvig P.: Artificial Intelligence: A Modern Approach, Vol.1. Pearson Education (2010)
- [4] Bertola P.; Teunissen J.: Fashion 4.0. Innovating the fashion industry through digital transformation, Research Journal of Textile and Apparel, Vol. 22, no. 4. pp. 352-369., 2018.
- [5] S. Ren, P. Chi-Leung Hui, and T.-m. Jason Choi: AI-Based Fashion Sales Forecasting Methods in Big Data Era, in Artificial Intelligence for Fashion Industry in the Big Data Era, Singapore, Springer, 2018, pp. 9-26.
- [6] R. Schmelzer: The Fashion Industry Is Getting More Intelligent With AI, Available from <https://www.forbes.com/sites/cognitiveworld/2019/07/16/the-fashion-industry-is-getting-more-intelligent-with-ai/> Accessed: 12. Nov. 2019.
- [7] J. Standish J.; Ganapathy V.: Think Tank: How AI Can Power the Future of Fashion, Available from <https://wwd.com/business-news/business-features/jill-standish-think-tank-1202941433/> Accessed: 14 April. 2020.
- [8] Sheldon P.: Augmented reality in retail: Virtually try before you buy Available from <https://www.technologyreview.com/s/614616/augmented-reality-in-retail-virtual-try-before-you-buy/> Accessed: 14. January 2020
- [9] Nike.com: How Nike Fit Works, Available from <https://news.nike.com/news/nike-fit-digital-foot-measurement-tool> Accessed: 27. May 2020
- [10] Mutchler A.: Amazon Takes The Fashion Angle with New Echo Look, Available from <https://voicebot.ai/2017/04/26/amazon-takes-fashion-angle-new-echo-look/> Accessed: 20 April. 2020.
- [11] Algorithm-Driven Design <https://algorithms.design/> Accessed: 02. August 2020

Author:

Dr. Edit CSANÁK

Product Design Institute, Rejtő Sándor Faculty of Light Industry and Environmental Engineering, Óbuda University

Doberdó út 6, 1034 Budapest, Hungary

Phone: +(36) (1) 666 5930

Mobile: +(36) (30) 667 3639

E-mail: csanak.edit@rkk.uni-obuda.hu

E-CLOTHING FOR STAGE PERFORMANCES

Snježana FIRŠT ROGALE; Dubravko ROGALE & Daniel ČASAR VELIČAN

Abstract: *The development of e-clothing and the integration of various types of technical components have led to more and more talk about the so-called cyber-look. The integration of various types of sensors, LEDs, electronic devices and the like causes more and more attention to be paid not only to the technical functionality but also to the aesthetic component, which is particularly important in the clothing for stage performances. The growing commitment of artists and the desire of all, especially artists, for unique e-clothing, the so-called cyber-look, has contributed to the aesthetic component of e-clothing. The paper will present clothing for stage performances developed in the world, but also clothing designed and developed at the Faculty of Textile Technology at the Department of Clothing Technology. Clothing for stage performances with special light effects is described, which was inspired by Tesla's attributes of refinement, light, remote control, radio control and fascinating presentations, and displayed by the use of a large alphanumeric display with built-in microcomputer*

Keywords: *e-clothing, Cyber looka, stage performance, sensors, Tesla*

1. Introduction

Decades before Google developed Google Glass (2013) and Apple Smartwatch (2015) **William Stephen George Mann**, a professor and innovator of the **Massachusetts Institute of Technology**, strapped a computer to his head and began an experiment with wearable computing. Known as “the world’s first cyborg” and “the father of wearable computing,” he has spent more than forty years with one eye in the real world, and the other focused on augmented reality, [1].

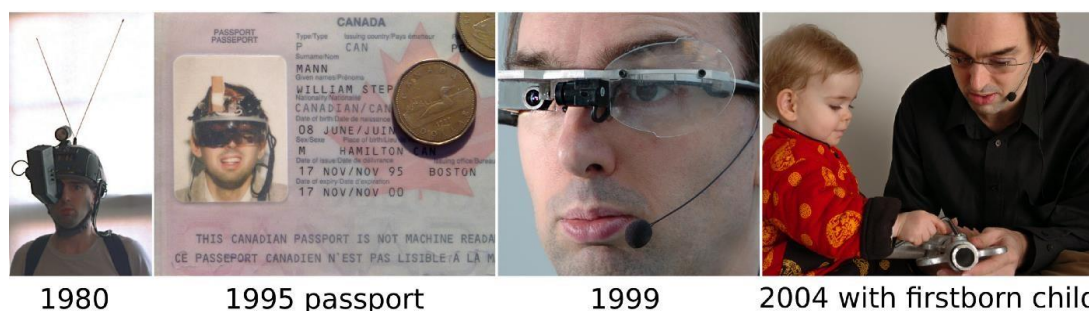

Figure 1: Professor Mann: Evolution of wearable computing in everyday life [2]

Since 1980 he has been researching and solving the technical problems of unhindered use of computers and their peripherals in people who are on the move. Wearable Computers are computers that are put on the human body, Figure 1. This type of clothing technology began to be used for behavioural research, health monitoring, as a supplement to information technology and during the development of entertainment media [3]. The fashionable expression of smart clothing is as important as other features. By integrating electronic and electrical devices into smart clothing and the so-called cyber-look smart clothing is particularly popular with young people who are sovereign users of the products of modern technologies.

2. Cyber look of e-clothing

In many films, theatre performances, concerts and other stage performances, smart and e-clothing have shown a specific fashionable expression that is averse to the classic and commercial concept of fashion by integrating electronic components or LE diodes into clothing. In this way garments were designed that had a practical function or only an aesthetic component. One of the first such examples is certainly the scene from the cult film *Back to the Future Part II* from 1989 in which Michael J. Fox, who plays the character of Marty, wears Google-like glasses, a self-drying jacket or self-lacing basketball shoes.



Figure 2: Self-drying jacket (a) [6] and self-lacing basketball shoes (b) [7] from Back to the Future Part II

At the **Museum of Science and Industry** in Chicago a Galaxy dress in cyber-look, which was designed at the fashion house **CuteCircuit**, is exhibited. The dress consists of 24.000 LE diodes having dimensions 2x2 mm, woven into silk chiffon and organza. The diodes are powered by several batteries used for the iPod and are hidden inside the dress [4]. The mentioned fashion house designed the dress with 3200 LE diodes for **Katy Perry**, who wore it at the Met-Gala in 2010 [5].

The Met Gala Ball is held once a year as the Metropolitan Costume Institute Charity Ball at the Metropolitan Museum of Art in New York City. In 2016, the theme of the Met Gala Ball, which was held under the auspices of Apple, was Manus Machina Fashion in an Age of Technology, with the aim of showing a combination of technology and fashion. **Zac Posen** designed a dress for the famous American actress **Claire Danes**. The dress is sewn from a special hand-woven organza with optical fibres that shine thanks to 30 mini-batteries sewn under the dress.



Figure 3: Cyberlook dresses of the fashion house CuteCircuit (a) [5] and the fashion designer Zac Posen [8]

Figure 4 shows a dress with an LED screen where users can send messages via Twitter. E-clothing with LE diodes is equally popular with performers of modern dance, Figure, 5 and classical ballet, Figure 6. Theatre lighting is great for emphasizing what is happening on the stage. These lights not only make a brighter space but can create a more intriguing and invigorating experience for audiences [10]. Figure 7 shows ballet slippers which, by programming the Lilypad microcontroller, follow the movements of the

dancer's feet and send them to smartphones or computers in form of digital drawings. In this way, the instructor can follow her movements in real time and/or analyse them subsequently [11].

Philips Design has developed a collection of garments that are able to sense the emotions of wearers and people close to the clothing and to change colour and pattern according to these senses [12]. The Buble Dress is one of the garments designed and made by Phillips Design. It is made up of two layers, the inner layer contains biometric sensors detecting changes on the wearer's body, and the outer layer is used to track these changes with light emissions using LEDs. Another example is the so-called Frison costume, which clings to the body and also contains LE diodes and sensors that respond to the breath and movement of air along the body and create visual effects.



Figure 4: #tweetthedress [9]



Figure 5: Cyber-look of modern dance

Mezzo-soprano **Cary Ann Rosko** promoted the Lucentury dress, which contained 76 groups of built-in LE diodes that emit diffuse light through the textile fibre system. During C. A. Rosko's singing, the lights imitate the tone and dynamics of the voice, and during the pause between songs the lights imitate the tone and dynamics of the musical accompaniment [3].



Figure 6: Cyber look for classical ballet [10]



Figure 7: Ballet slippers with embedded microcontroller [11]

Dutch designer **Anouk Wipprecht** designed the so-called the Pseudomorph dress [13]. The Pseudomorph dress makes use of moving liquids to paint a dress, while it's already being worn. Wipprecht uses a simple, white dress made from felt, and electronic equipment and then puts it all together to work with the custom-made neck brace. He then connects a series of tubes to the neck brace, and then leads them down to the wearer's back, where a pack will hold the colour chosen to paint the individual dress. Using pneumatic valves, the colour is fed into the tubes and poured over the dress.



Figure 8: The Pseudomorph dress [13]

Anouk Wipprecht also designed the so-called spider dress, which is equipped with sensors, robot mechanics and 3D printed parts and whose system works on the Intel Edison platform, or a computer system intended for portable gadgets. The dress works by incorporating proximity sensors that detect when someone gets too close to the wearer while biometric sensors simultaneously measure the stress level. So when the computer detects anxiety, it activates the dress's defence system, which spreads the spines (spider legs) [14].



Figure 9: Spider dress by Anouk Wipprecht [14]

Her interesting innovation is also a dress that represents a kind of Faraday cage. The dress is knitted from 600 metal rings and is additionally equipped with a helmet that protects the head from dangerous lightning and allows it to be worn under the strikes of half a million volts of Tesla's transformers [15].



Figure 10: The dress representing a kind of Faraday cage [15]

An innovation inspired by Tesla and his achievements was developed in the **Department of Clothing Technology at the Faculty of Textile Technology**. Innovation Remote-controlled light effects on clothing repeatedly symbolise Tesla, Figure 11.

Tesla is a symbol for the master of lighting with alternating current transmission over long distances, so it symbolises both light and light effects on the clothing of the innovation concerned. Furthermore, the clothing itself is a symbol for Tesla, as Tesla was always carefully dressed and attracted attention when presenting his experiments because of his recognizably slim figure dressed in decent clothes. The innovation concerned is remotely controlled, and it is known that Tesla was the first to demonstrate the principles of remote control by operating the test model of a small boat, which is the third connection between Tesla and the innovation concerned. The fourth connection between Tesla and the innovative product presented as a piece of utility clothing is the radio remote control of resonance coils and capacitor connections, which, as it is known, Tesla patented and that the US Supreme Court granted him his patent rights because of Marconi's theft of intellectual property and the long-standing misuse of Tesla's invention.

To make innovation tangible, remote-controlled light effects on garments require a battery-powered microcontroller built into the garment, to which a miniature radio receiver is attached as a receiving unit to receive control signals, and output devices in the form of a matrix of LED elements to create light effects.

To make innovation tangible, remotely controlled light effects on clothing require that a battery-operated microcontroller is installed in the garment, to which a miniature radio receiver is attached to receive control signals and output devices in the form of a matrix of LED elements used to create light effects, as a receiving unit. This creative and innovative product is intended for stage performances the appearance of which is enhanced by light effects, Figure 12.

An integral part of the innovation is the transmitter as the transmitting unit, which is used to remotely control the microcontroller, and pre-designed light effects are controlled by the program stored in the microcontroller. Light effects can be produced by controlling the colour, intensity and different spatial integration of individual lighting elements (LE diodes) of different time duration.

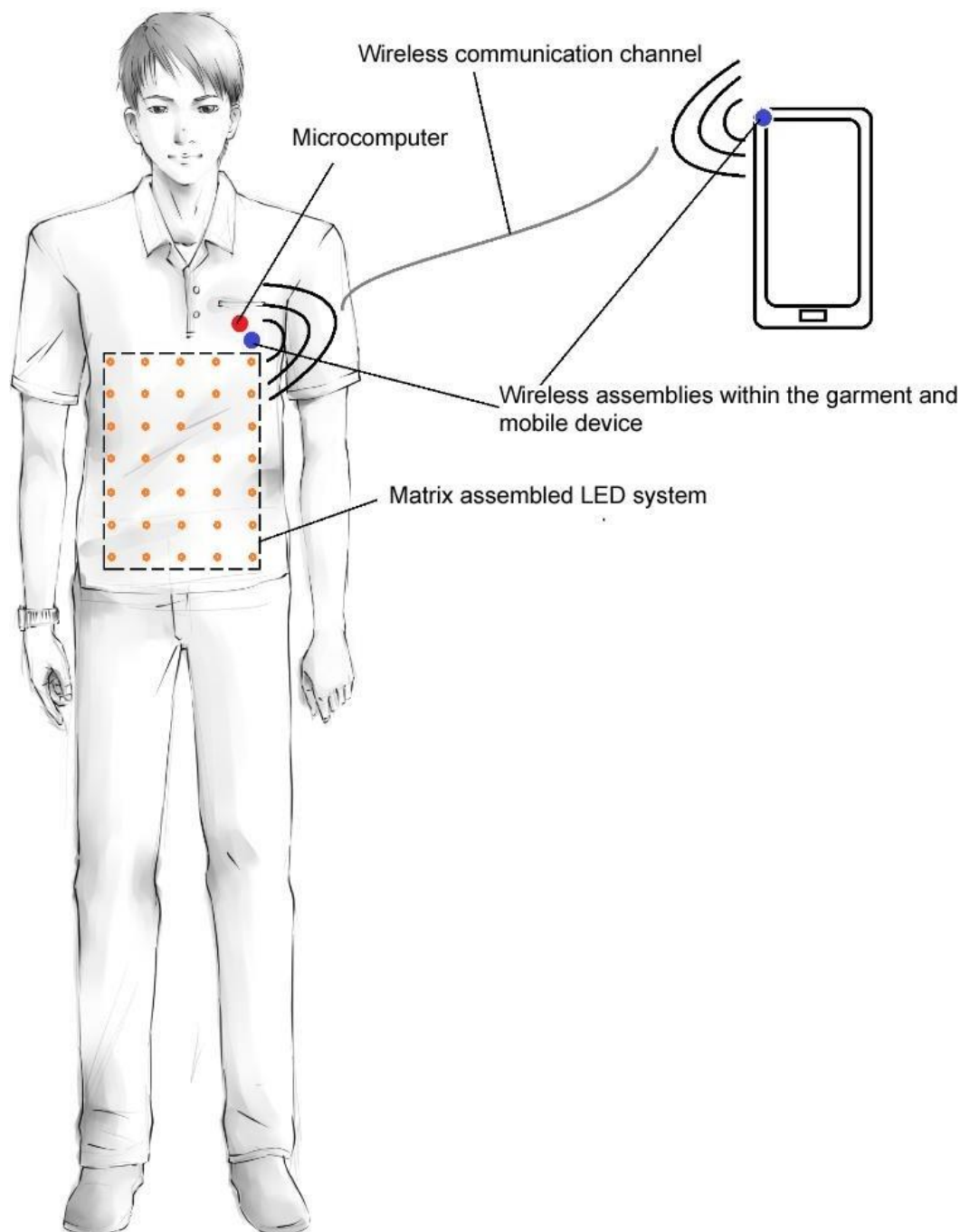

Figure 11: Remotely controlled light effects on clothing [16]

If the lighting elements are designed in the form of matrices, it is also possible to display letters, i.e. text or visual symbols on them. The promotional film shows the remote control on the matrix of LEDs with the word TESLA printed on it. Identically, it is possible to remotely control multiple garments with built-in lighting effects simultaneously if more people are engaged in the stage performance, which can add an extra creative component and drama or an eye-catching stage performance. In addition to program remote control, it is possible to remotely control lighting effects, which can be produced by symbolizing changes in the emotional status, intensity and rhythm of the music or according to some other ideas of the authors of stage performances, in order to enhance a certain impression.

It is possible that commercialization can increase the impact of sophisticated stage effects of glamorous performances such as fashion shows, dance performances, award ceremonies, promotions and the like.



Figure 12: Remote control on the LE diode matrix with the word TESLA printed on it

Today, e-clothing is not only used for stage performances, but it can also serve the audience. Sound Shirt is a garment designed for people with hearing impairment to feel the beauty of music, Figure 13.

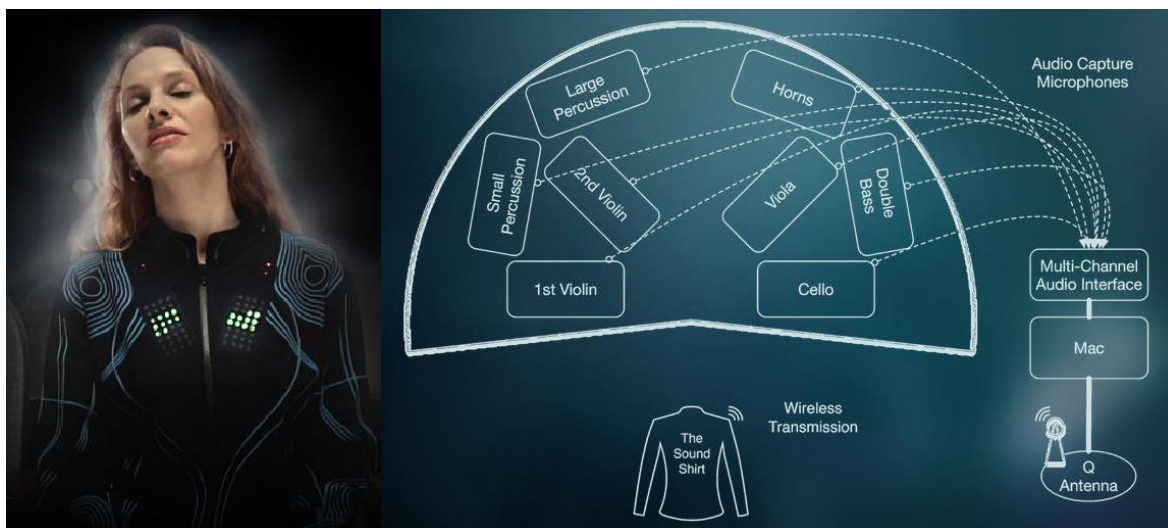

Figure 13: Sound Shirt [17]

The microphone collects the sounds of eight different types of instruments that are located at specific points on the stage. The software translates them into data that is sent wirelessly to the Sound Shirt so that the 16 microactuators, sewn into the garment, vibrate with a certain intensity and thus enable a real symphony concert for the deaf, making it an unforgettable experience [17].

3. Conclusion

E-clothing belongs to a group of garments that has a lower level of technical complexity and is therefore different from smart and intelligent clothing. Nevertheless, even with this level it is possible to achieve numerous and interesting stage effects. Therefore, in the realization of such clothing, apart from experts in the field of clothing technology and electronic technologies, clothing designers also play an important role. The development of such clothing is for these reasons extremely multidisciplinary. The development team combines knowledge and creativity, and the resulting clothing has a high artistic and technical added value. Depending on the designer's inspiration, such clothing can significantly increase the stage expression, the impression of the play and the memory of the stage performance, which gives a new value to the artistic and stage effect in the lives of contemporary people who are constantly striving for innovation, especially in terms of aesthetics and art.

Acknowledgements



This paper was written within the Research project HRZZ IP-2018-01-6363: Development and thermal properties of intelligent clothing funded by the Croatian Science Foundation

References

- [1] Kennedy D.: Tech pioneer thinks wearables can offset privacy concerns Available from <https://www.theglobeandmail.com/technology/steve-mann/article24859767/>, Accessed: 2020-07-02
- [2] Nelson J.: Wearables today, Available from <https://medium.com/@jilliantnels/wearables-today-570bd94f4fef>, Accessed: 2020-07-02
- [3] Firšt Rogale S., Rogale D., Nikolić G., Dragčević Z.: Inteligentna odjeća, Tekstilno-tehnološki fakultet Sveučilišta u Zagrebu, 978-953-7105-52-5, Zagreb (2014) 398.
- [4] Weir J.: Cute Circuit Galaxy LED Dress, Available from <https://crunchwear.com/cute-circuit-galaxy-led-dress/>, Accessed: 2020-07-02
- [5] Katy Perry-Met Gala Dresses, Available from <https://www.wmagazine.com/gallery/katy-perry-met-gala-dresses/#4>, Accessed: 2020-07-02
- [6] Self-Drying Jacket worn by Marty McFly (Michael J. Fox) in Back To The Future Part II Available from <https://www.spotern.com/en/spot/movie/back-to-the-future-part-ii/49031/self-drying-jacket-worn-by-marty-mcfly-michael-j-fox-in-back-to-the-future-part-ii/>, Accessed: 2020-07-02
- [7] Lawler R.: Nike's first self-lacing basketball shoes go on sale in 2019 for \$350 Available from <https://www.engadget.com/2018-12-20-nike-self-lacing-basketball.html>, Accessed: 2020-07-02
- [8] Chi P.: Met Gala 2016: Claire Danes's Glow-in-the-Dark Gown Upstaged a Red-Carpet Robot Army Available from <https://www.vanityfair.com/style/2016/05/met-gala-2016-red-carpet>, Accessed: 2020-07-02
- [9] Nicole Scherzinger and CuteCircuit team up for a light-up Twitter dress Available from <https://i.pinimg.com/originals/4a/20/37/4a20372cb6e6f20f89fc70d92d0b5ba4.jpg>, Accessed: 2020-07-02
- [10] Abram D.: Cool LED Lights Used for Entertainment Available from <https://www.homeelectrical.com/cool-led-lights-used-entertainment.6.html>, Accessed: 2020-07-02
- [11] Kamiloska V.: Top 13 Smart Shoes That Combine the Best of Technology and Fashion Available from <https://www.techflier.com/2016/06/08/top-13-connected-smart-shoes-that-combine-the-best-of-technology-and-fashion/>, Accessed: 2018-12-12
- [12] Mura G.: Wearable Technologies for Emotion Communication, METU Journal of the Faculty of Architecture, 1 (2008) 25, 153-161
- [13] Selleck E: Pseudomorph Dress Paints Itself Using Pneumatic Control Valves Available from <https://www.slashgear.com/pseudomorph-dress-paints-itself-using-pneumatic-control-valves-video-07106551/>, Accessed: 2020-07-02
- [14] S.I.: Intelova robotska pauk haljina za samoobranu Available from <https://www.vidi.hr/Racunala/Novosti/VIDEO-Intelova-robotska-pauk-haljina-za-samoobranu/>, Accessed: 2020-07-02
- [15] 2014 Bay Area Maker Faire - Anouk Wipprecht, Fashions and Tesla Coils Available from <https://wayne-yoshida-kh6wz.com/2014/05/22/2014-bay-area-maker-faire-anouk-wipprecht-fashions-and-tesla-coils/>, Accessed: 2020-07-02
- [16] How to Draw People Available from <https://www.wikihow.com/Draw-People>, 2020-07-02 prilagođena slika
- [17] Sound shirt - Enabling deaf people to feel classical music Available from <https://sound-shirt.jimdofree.com/english-1/> Accessed: 2020-07-02

Authors:

Prof. Snježana FIRŠT ROGALE, PhD.
Prof. Dubravko ROGALE, PhD.
Daniel ČASAR VELIČAN, mag.ing. tex. tech. (corresponding author)
Sveučilište u Zagrebu Tekstilno-tehnološki fakultet
Prilaz baruna Filipovića 28a, 10000 Zagreb, Hrvatska
Phone: +(385) (1) 3712553 Fax: +(385) (1) 3712599

E-mail:
sfrogale@tff.hr;
dubravko.rogale@tff.hr;
daniel.casar.velican@tff.hr

THE FOURTH INDUSTRIAL REVOLUTION IN CLOTHING PRODUCTION

Vasilije PETROVIĆ, Gordan SMUĐ, Marija PEŠIĆ, Anita MILOSAVLJEVIĆ,
Marija PETROVIĆ & Jovana STEPANOVIĆ

Abstract: This paper defines the 4.0 Industrial Revolution that is reflected in digitization and interconnection of every machine in the company, every technological component and practically every piece of material that goes through the manufacturing process of garment manufacturing. In order to make the vision of smart textile factory a reality, this paper discusses the needs of investing in research and development, as well as in education of personnel. A “smart factory” concept is explained and it allows links between innovation subject, universities and other educational institutions, industry in the areas of procurement and distribution, as well as state administration and banks. There are 4 key innovative topics highlighted that will shape the textile and apparel industries of the future: advanced materials, digitalization, sustainability and emerging growth markets. The example of the French company Lectra explains the digital transformation of the clothing industry in strengthening brands and manufacturers from design to production. The influence of the generation of Millennials born in 1980-2000 on changes in the fashion market is explained. They make up 20-30% of the world's population, can access the world from their own pocket, seek personal style, and want instant results in production.

Keywords: 4.0 industrial revolution, clothing production, millennials, personalization

1. Introduction

Industry 4.0 is a new concept of work organization in the industry and service sectors. This term was mentioned in Germany in 2011 by Deutsche Working Group. The aim of this concept promotion is reflected in the direction of investment in projects for industry modernization in the new conditions of widespread digitalization which is enabled by technique development. The main goal is adoption of new, modern work processes by developing techniques and products. Requirements are being made of necessary response to changing market demands, as well as aggressive and increasing competition [1-4].

2. The fourth industrial revolution

The European Technology Platform (ETF) for the future of textiles and clothing is the largest European network that is dedicated for research and innovation in textiles (bringing together 500 experts). This network gives the following definition: The industrial revolution 4.0 is digitalization and interconnection of every machine in the company, every technological component and every piece of material that goes through the production process [5]. The development of the 4.0 Industrial Revolution requires significant investments in research, development and work education so the vision of a smart textile factory could become a reality.



Figure 1: 4.0 Industrial revolution is integral for businesses to face challenges [6, 15]

The European Technology Platform defines four key innovative topics that will shape the textile and clothing industry of the future and those are: advanced materials, digitalization, sustainability, new growth markets [5]. Although it is expected that these events continue, additional powerful innovators will affect the future of this industry in the coming years. This includes the digitalisation of products, processes, factories, jobs, supply chains, distribution and retail. A key feature of the Industry 4.0 concept is [1-4]: full digitalization, computer

monitoring and management of production and business processes, mutual communication of M2M (Machine to Machine), H2M (Human to Machine) and M2H (Machine to Human). Enabling machines, devices, sensors and humans to connect and to communicate on relation Internet of things (IoT) or Internet of people (IoP). It is necessary to unify the machine language, because there are many protocols and transport media that makes almost impossible merging and sharing data about machine.

Concept of industry 4.0 is about a "smart factory" that uses information and communication technology for production managing and manufacturing processes within marketplace, achieving better quality, low cost and flexible manufacturing of custom products. For "smart factory" is used the name "learning factory". This name is used because, in accordance with changes in the market, technology, science, available resources involved, the staff is continuously educated, and the company is immediately or quickly adapting to new conditions [7-8].

Intelligent production will lead to lower product prices, which will attract a large number of new customers in the market. In addition, intelligent production opens the possibilities for providing additional customer service. Special emphasis is placed on personal production. It is the possibility of individual production for a known customer, according to his requirements, which thus participate in the creation of the product. The virtual creation of the products makes a new form of communication with customers. This raises the possibility for involving the wishes of customers in the process of experimenting with new products and its design [3-4].

3. Industry 4.0 - application in clothing production

Nowadays, the automation of clothing production isn't completely done, because in the industrial production of clothing, the participation of human labour in the final product is from 60-70%. However, changes in the market shows that, in addition to mass production, there is a growing demand for custom made industrial clothing. There is a personal production that wants to comply with the requirements of each individual customer. This opens a new business challenge for conversion of production lines from large series to mass production. Mass production refers to a large number of products of the same production process but different: dimensions (size numbers), cuts, patterns, etc. This is a solution that represents the application of ideas and principles of the clothing industry 4.0 [7-8].

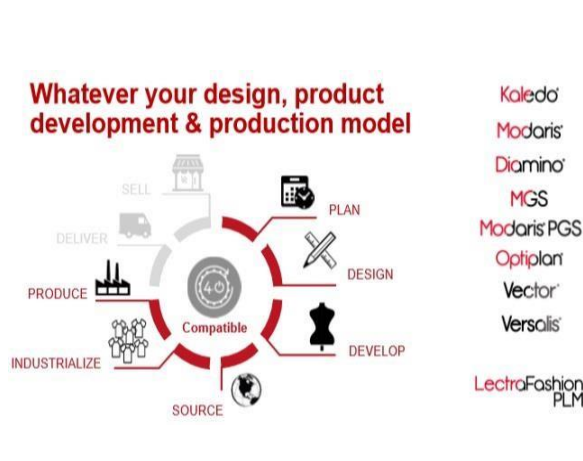

Figure 2: Lectras production model [6, 15]

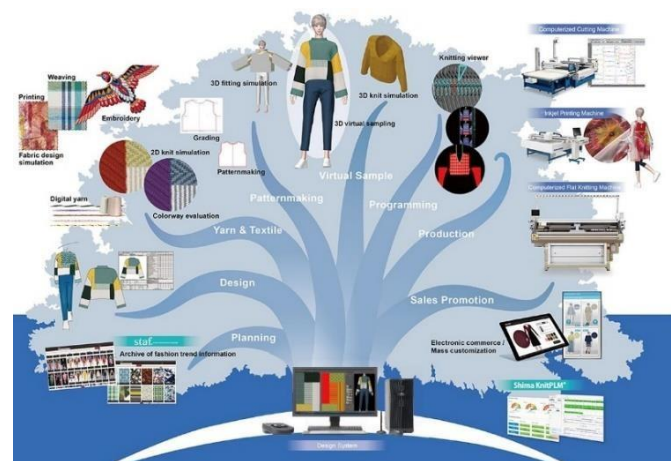

Figure 3: 3D system for design – APEKS that connects all manufacturing activities in the form of the large tree [9]

An example, of today's developed system from design to clothing production is partly automated and includes: automatic taking measures of the customer, automatic correction of cutting parts according to customer's needs, virtual fashion show, model trying out, correction of identified deficiencies, partial automation of production and delivery to the customer of ready-made clothing product. The production models of companies Lectra (Figure 2), Shima Seiki (Figure 3) and a large number of companies from fashion sector can be mentioned as examples.

The digitalization of production for the conversion from mass production to individual (personal) production is offered by the French company Lectra. The difference in the production process between mass and individual production is shown in Figure 4.



Figure 4: Mass and individual production [6,15]

A key development segment offered by Lectra is the digitized production department for cutting. This new solution for cutting department is capable to receive individual customers orders from just one clothing product in a production series. The production system provides the implementations of all requirements of the customer for the production of only one garment with the desired design, garment size, etc. A very strong computer is required to process all the information about clothing product that customers require. Individual companies can not have this. For this reason, Lectra uses a "cloud", i.e. a shared computer or data centre, which is quite geographically distant from the companies. All companies connect to this center through the internet where they process their data. The processed data are returned to the company very quickly and serve to realize the production of the desired clothing product according to the technical characteristics specified by the customer [6, 15].

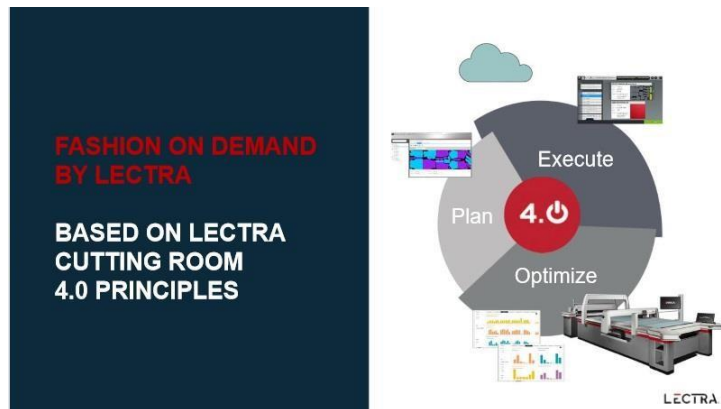

Figure 5: Lectra's cutting department based on 4.0 principles [6,15]

The new solution for the activities line offered by Lectra, is shown in Figure 6.

HOW FASHION ON DEMAND CONNECTS YOUR ACTIVITIES

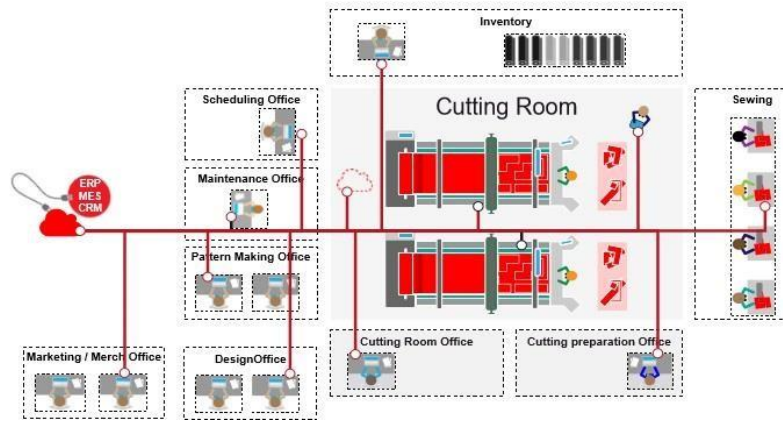

Figure 6: Lectra's line with activities for personal production [6, 15]

The main segment of new digital solutions offered by Lectra is their cutting machine (cutter) and it is shown in Figure 7.

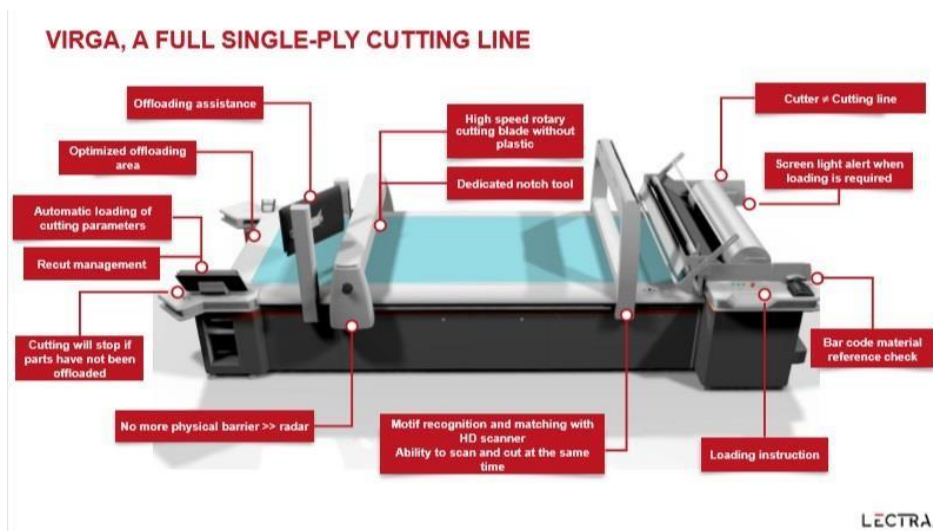

Figure 7: Lectra's cutter 4.0 [6, 15]

The thinking of large companies to change their production to personal production is due to the new generation of customers which uses the name Millennials. It is a generation born between 1980. and 2000. Millennials have access to product purchases that are very different from previous generations of customers. Figure 8 shows this generation.

The influence of Millennials



Figure 8: Millennials generation [6, 15]

They make 20-30% of the world's population, can access the world from their own pocket, seek personal style, want instant results ...

4. Personnel in the industrial revolution 4.0

It follows from the foregoing that jobs related to the use of computers and data processing (IT) will be required in the textile and clothing industries in the future. The textile and apparel industries will increasingly need personnel for robots and their programming, then personnel for industrial data processing, designers, or architects of IT solutions. Also, analysts of a large number of data, artificial intelligence and robotics experts, mobile application developers, web developers, database administrators, business intelligence analysts, designers, business systems analysts, etc. will be required. Previous occupations will also be required: clothing and textile technology engineers, financial experts, lawyers, project managers, etc. [1-8].

A key problem in the future will be a staff training for the digitalization of textile and clothing sector. Do we have the staff today for the goals of the 4.0 Industrial Revolution? What is the current situation? Here is an example of Serbia and the situation of other countries in the region, we believe is not much different. There are 2000 companies, today in Serbia, engaged in the production of textile yarns, fabrics and finished textile products. For textile, clothes and leather there is 64.156 employed workers: 12.679 in textile production, 37.116 in garments, 14.361 in leather production. In the period January - December 2018, in the total textile industry of Serbia, exports were realized in the amount of 960.3 million dollars [10].

The big question is whether a trained non-textile worker, who works with software can work on e.g. optimization of costs by considering the size of pattern repeats. The major obstacle, today, for the implementation of CAD/CAM in the clothing production are training of the operators for work with maximum equipment benefit [11-14].

The major manufacturers of modern CAD / CAM solutions offer the possibility of obtaining production data, which largely provide making rational decisions that can significantly reduce production costs (Figure 9). Therefore, at Technical faculty „Mihajlo Pupin“ University of Novi Sad, students training methods are directed to the fact that the use of CAD / CAM systems minimize production costs. Namely, the right decisions of cost rationalization are made mainly on the basis of so called "Hidden time" in production that is difficult to see without information from the production process analysis provided by CAD / CAM solutions. So e.g. different cost reduction scenarios may be considered when fitting cutting patterns.

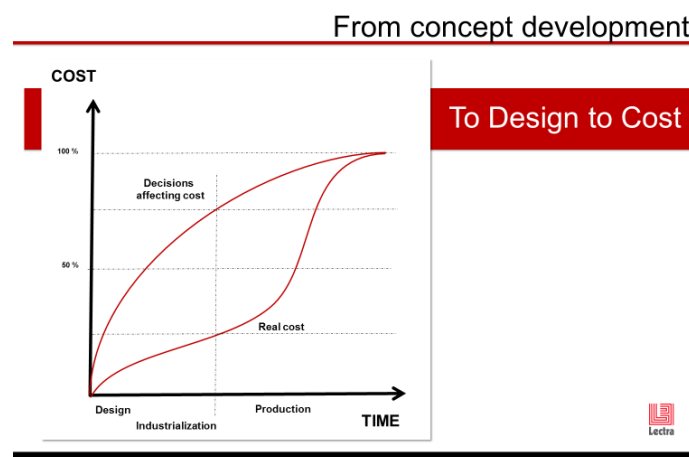

Figure 9: Cost rationalization [6,15]

During the process of product development, many production parameters can be combined. Thanks to CAD / CAM advanced solutions, their impact on material production costs can be properly evaluated. Where are the cost reduction areas? Fabric design itself - basic material, garment design, pattern fitting, sewing method and more. According to research from the French company Lectra (Figure 10), if, for example, in the initial combination of clothing, the following scenarios apply: 1) rotation of the patterns on the fabric by 90° - the fabric consumption of fitting cut-outs by 6% will be reduced; 2) if the basic material for garments is combined in combination - it will reduce consumption by 11,23%; 3) if the size of the pattern on the fabric is reduced from 25 cm to 17 cm - the consumption will be reduced by 12%. Summarizing the various changes and their impact on overall efficiency (Figure 10) we conclude that an operator who does not know what a fabric pattern repeating is, cannot use the capabilities of above mentioned industrial software [6, 15].

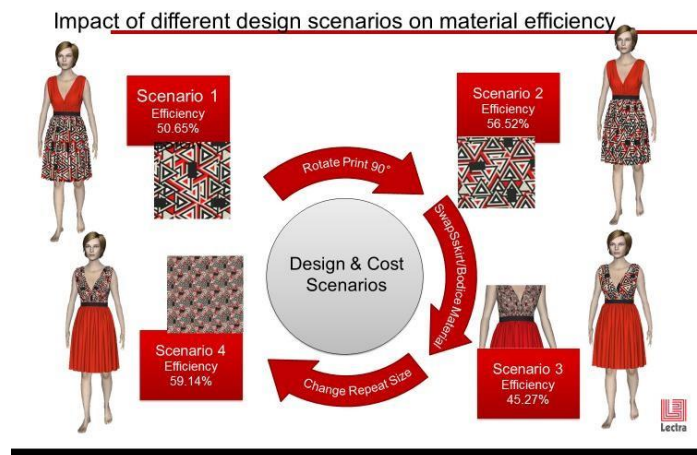

Figure 10: Summarized various changes and their impact on overall efficiency [6,15]

5. Conclusion

The 4.0 Industrial Revolution is represented by digitalization and interconnection of every machine in the company, every technological component and practically every piece of material that goes through the manufacturing process of clothing manufacturing. The goal of the 4.0 Industrial Revolution is reflected in vision to textile "smart factory" became a reality. The "smart factory" provides relationship between innovation entities, universities and other educational institutions, industry in the areas of procurement and distribution, training of personnel, as well as with government and banks. The four key innovative themes that will shape the textile and clothing industry of the future are: advanced materials, digitalization, sustainability and emerging growth markets. Of great importance is the training of personnel for the new jobs in the industrial revolution 4.0. In the case of French company Lectra the digital transformation of clothing industry is explained. The influence of the generation of millennials born between 1980-2000 on changes in the fashion market is explained. They make up 20-30% of the world population, can access the world from their own pocket, they look for personal style, want instant results,... During the process of product development, many production parameters can be combined. The paper presents an example of a combination of production parameters that shows a 29.23% reduction in material consumption.

References

- [1] Petrovic, V. et. al.: Digitalization in the textile industry – 4.0 Industrial revolution in clothing production, International Joint Conference on Environmental and Light Industry Technologies, 7th International Joint Conference on Environmental and Light Industry Technologies, The Faculty of Light Industry and Environmental Engineering of Obuda University, 21-22 of November 2019, Budapest, Hungary, pp. 11-21.
- [2] Petrovic, V.: How digital is the Adriatic Textile Industry? Reality and Trends, International Conference Digital Fashion, Lectra Deutschland GmbH, Zagreb, 2019. pp. 42-52.
- [3] <https://futura-automation.com/2017/10/15/industry-4-0-will-manufacturers/>, Accessed 01.11.2019.
- [4] <https://www.tandfonline.com/doi/full/10.1080/00207543.2019.1652777>, Accessed 29.12.2019.
- [5] <http://www.textile-platform.eu/>, Accessed 15.01.2020.
- [6] <https://www.lectra.com/en> - accessed 04.02.2020.
- [7] Nikolić G.: *Industrija 4.0 i obrazovni sustav*, Open Info Trend, 207/3/2018, pp. 28-36.
- [8] Nikolić G., Rogale D.: *Industrija 4.0 - pravac razvoja tekstilne i odjevne industrije*, Tekstil, Vol. 66, No. 3-4, 2017, pp. 65-73.
- [9] <http://www.shimaseiki.co.jp>, Accessed 10.02.2020.
- [10] <https://pks.rs/>, Accessed 01.02.2020.
- [11] Rogale D. et. al.: *Procesi proizvodnje odjece*, Tekstilno - tehnoloski fakultet, Univerziteta u Zagrebu, (2011).
- [12] Petrovic, V. et. al.: *Modna kolekcija*, Tehnicki fakultet „Mihajlo Pupin“, Zrenjanin, 2016., ISBN 978-86-7672-257-0, COBISS.SR-ID 299045383.
- [13] Ujević D. et. al.: *Tehnike konstruiranja i modeliranja odjece*, Tekstilno - tehnološki fakultet, Zrinski d.d., Čakovec, Zagreb, (2010).

- [14] Petrovic, V. et. al.: Savremena kretanja u tekstilnoj i odevnoj industriji u Evropi, Menadzment, Inovacije, Razvoj, Volume 8, No.1, str. 83 - 89, (2013). UDK005, ISSN 1452-8800.
[15] Technical information, Lectra, 2020.

Authors:

Vasilije PETROVIĆ (corresponding author)
Marija PEŠIĆ
Marija PETROVIĆ
Anita MILOSAVLJEVIĆ
University of Novi Sad, Technical faculty "Mihajlo Pupin"
Đure Đakovića 66, Zrenjanin 23000, Serbia

E-mail: vlp@eunet.rs

Gordan SMUĐ
Regional Account Manager - Adriatics Region at Lectra
Lectra Deutschland GmbH, Buzin, Buzinski prilaz 10, Zagreb
Phone: +(385) (1) 3906 842

E-mail: g.smudj@lectra.com

Jovana STEPANOVIĆ
University of Nis, Faculty of Technology
Bulevar oslobodjenja 124, 16 000 Leskovac, Serbia

CREATIVE THINKING TECHNIQUES - STRATEGIES FOR SUCESSFULL DOCTORAL RESEARCH

Ivana SALOPEK ČUBRIĆ; Ines KATIĆ KRIŽMANČIĆ; Branka TOMIĆ

Abstract: *It is widely accepted and confirmed in a number of policies that creativity and use of creative thinking techniques have an important role in almost every segment of scientific research. Despite this, the number of published papers focused at designing scientific processes with the inclusion or consideration of the creative techniques is rather limited, especially in the field of engineering. It is a common opinion that scientific design research should embrace those techniques in order to effectively manage and improve the level of achievements. In the preparation of this paper, over 50 different creative thinking techniques have been analysed and considered in total. The most appropriate for the doctoral research in the field of textile engineering have been selected for comparative purposes. The paper discusses advantages and disadvantages of selected creative thinking techniques and describes at how those techniques can be used to design practical solutions to scientific research problems. The paper specifically gives guidelines and recommendations for their use in doctoral research in the field of textile technology.*

Keywords: *creativity, doctoral research, technique, textile, method*

1. Creativity

Transversal or soft skills complement hard skills, which are about a person's skill set and ability to perform a certain type of task or activity [1]. They have been defined as a dynamic combination of cognitive and meta-cognitive skills, interpersonal, intellectual and practical skills. Transversal or soft skills help people to adapt and behave positively, so that they can deal effectively with the challenges of their professional and everyday life. It is well-known and confirmed in a number of studies that such skills are increasingly valued for employment [2]. Regarding the relevance of soft skills for employability, many research projects have been focused towards the investigation of this topic from different perspectives. As a result of investigations, the development of soft skills has already been established as a necessity among employers for the purpose of sustained growth of socio-economic benefits. Recently, the policy documents related to investing in skills published by European Commission outline that creativity, together with other transversal skills, will be valued more than the specific knowledge that schools have traditionally taught [3,4].

1.1 Importance of creativity

Prevailing opinion is that creativity is reserved and privileged only for artists and inventors. But creativity is also necessary to solve everyday problems in our lives.

The basic question is where ideas come from? The simplest explanation is that ideas are born when existing knowledge is combined in a new way. One can say that everything has already been invented but number of combination that is given is unlimited. For example, the drone is a compound of mini aircraft, toy and a camera. Designer's piece of clothing is a new compound of existing forms, colours and textures. If new ideas are born from a combination of existing ideas, for creativity, we need a large database that we can easily call knowledge. That means the creativity and new ideas could not be created from nothing. As much informations we have, the number of new combination significantly increases. We haven't forgotten that foundation of the information was created by the people who worked before us. Kopernik hasn't created only the foundation of a new astronomy, his influence is not important only for scientific disciplines. It also changed worldviews to religion. Only producing new ideas can't be called creativity. Many of these ideas are not feasible or on the other hand can cause unintended consequences such as, for example, the idea of moving daylight saving time proved to be more harmful than it was original idea of saving energy. Creativity can be called the creation of new ideas that are particularly useful. This brings us to the important role of critical thinking in the field of creativity. Creative process is a series of trials and errors. Critical thinking allows us to learn from mistakes. In the business world the difference is between creative ideas and innovations. Innovations are the ones which get their commercial certificate on the market and also are socially responsible. Next misconception is that creativity is the moment of inspiration inspired with muses and mostly happens only to a genius. But history teaches us that all these geniuses were diligent and high disciplined people.

1.2 Creative cycle

Magic formula for moulding creative ideas doesn't exist. However we can do a lot to become more creative. Sometimes creative environment, certain routine, discipline or focus on the work that we love helps. No matter what, the creative cycle always goes through the same four steps that are preparation, exploration, incubation and verification [5]

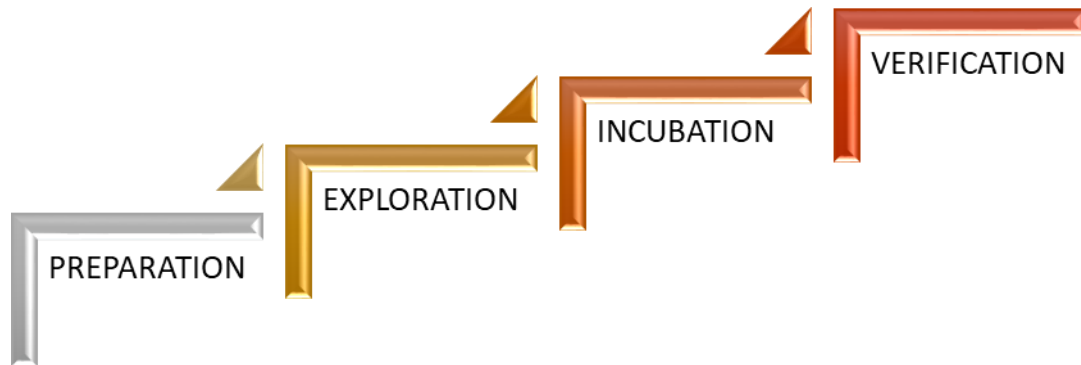

Figure 1: Four steps of creative cycle

Preparation process begins by collecting information related to the problem, collecting literature, using web or chat. Structuring annotations, collected without previous filter. Using all sources that might help it.

Exploration is a second step of classification and organization of data and taking view from a different perspective. The aim is to create new useful ideas. It takes time, needs patience and focus. Also, the following thing could happen: we can come to some preliminary idea which would work or not. We could find the holes in the collected material, and need re-collecting. Seeking order in the chaos causes mental exhaustion.

Incubation is a time moving away from the task and leaving it plenty of time to mature. This is the period when you should take rest, relax and give time to unconscious mind to do its thing. A good night's sleep can contribute to this stage of incubation. You can find some activity or inactivity to stimulate imagination. It doesn't mean that this pause always contributes a creative idea. If it didn't happen, we have to return to Step 1 and 2, and try again.

Verification is the last phase. Once we come up with some promising ideas we can try which of them work and can still improve them. Usually the first solution is the best. And once we find the best solution we go through the process that leads to success. We always talk about success, but ignore series of failures we had to go through. But without risk of failure there is no success. It is important to know why we failed and how to learn from it. Learn from mistakes.

Here are few main reasons why people fail in their creative endeavours [5]:

1. Failure due to lack of knowledge - we have to learn more
2. Failure of concept - wrong initial idea or theory. It also takes some luck. Fortuna favours the brave
3. Failure of judgment - It may be a good idea, but the path of realization has gone wrong
4. Failure of attitude - fear of failure, being honest with yourself and listening to the people you may trust.

2. Creative techniques

Creativity techniques encourage creative actions in different fields of human activity, whether in the arts, technology, sciences or something else. They focus on a variety of aspects of creativity and can be used as part of problem solving or expression. Some creative techniques can be accomplished alone, but majority require groups of two or more people. For successful use of creative techniques, it is important to select optimal technique for the problem to be resolved and be well informed about the procedure and possible modifications of a single technique. Nowadays, there is a number of creative techniques that continuously expand, but not all can be used in doctoral research. The list of selected creative thinking techniques that can be well used for this purpose with their main determinants is given in the Table 1.

Table 1: List of selected creative thinking techniques and their determinants [5,6,7,8,9,10,11,12,13,15]

Name	Main determinants
SCAMPER	A technique that helps creative thinking by observing something that already exists and improving it by using certain types of questions
Brainstorming	A group or individual technique that encourages creative and innovative solutions. The purpose is to create an environment where the group as a whole makes decisions, reduces the dominance of individuals and engages shy participants.
Six Thinking Hats	A simple but powerful parallel thinking technique used for analysing the situation or solving organizational problems. The technique consists of different thinking styles associated with hats of different colours. It forces all participants to adopt a particular thinking style represented by a hat of a particular colour
Concept map	The concept map is a teaching and learning technique that help visualize the connections between concepts and ideas. It helps organize thoughts and discover new relationships, ideas or concepts.
Mood Board	Visual representation and collection of initial materials to encourage the development and flow of ideas. Also, an effective communication tool in many sectors where information communicates better visually. Used as part of the design process.
Brain-writing	Also known as the 6-3-5 method, brain-writing is an alternative technique from brainstorming. There is no verbal communication here, everything is being written down which leads to a greater flow of ideas. It's faster than traditional brainstorming, it can generate twice as many ideas at the same time and more participants prefer it.
Brain-sketching	This technique allows you to express yourself visually through sketching ideas on large sheets of paper, including notes. The drawings are then exchanged and sketching continues for a while. The method is appropriate for product design, with participants building new ideas on previously generated ones.
C-K theory	With this design reasoning model, radically original ideas can be achieved by combining design capabilities that effectively deliver value and creativity. It addresses important problems that could not be solved by traditional theories, and offers a formal framework for interpreting existing design theories as special objects of a unified model of reasoning.
Gallery theory	A technique that enables social interaction through clarifying one's ideas. Individuals draw ideas without communication on large sheets of paper that other members of the group comment on after a while. Participants clarify their own and study others' ideas. This is followed by more sketching.
Business Process Reengineering: 20 Questions	Creative technique that encourages to consider broader design options and focus on the method. It works well as a design and analysis tool and it consists of several groups of questions that are asked in a specific order.
Delphi technique	A method used in scenario prediction and to create alternatives in the same way as individual brainstorming. It is great for bringing together the ideas of geographically separated experts. Ideas from individuals are collected, which they then combine together.
Self-management	Lifelong excellence in thinking and developing characteristics such as perseverance, courage, ability to do many different things, tolerance of mistakes and sense for mission. In short, having a passion for improvement by application and practice.
Analogy	A method of solving problems by comparing them to similar problems that have already been solved or by borrowing ideas from other sources (mimicry of nature). Efforts to solve problems, starting with the simplest version of the problem first.
Change of perspective	A method that emphasizes the importance of considering problems from a number of different perspectives that can have a significant effect on a solution. Changing perspective can give you a comprehensive picture of the problem, which can result in better ideas.
Breaking the rules	Creating original ideas by challenging and breaching established rules and doing things the other way.

Despite the fact that all listed creative techniques could be, in a certain way, used for scientific research, authors of this paper selected three techniques as more appropriate for use in the field of technical sciences. Therefore, the discussion will further focus on SCAMPER, brainstorming and breaking the rules techniques.

2.1 SCAMPER

The SCAMPER technique was introduced by Alex Osborn who during his career observed in his brainstorming sessions that the most of new innovations were in fact changes on something that already exists [14]. The term SCAMPER is mnemonic technique compound of first letters of the 7 questions that need to be answered to improve a product or a service i.e. Substitute, Combine, Adapt, Modify, Put to other use, Eliminate, and Reverse.



Figure 2: Model of SCAMPER technique

In doctoral research, this technique can be widely used, especially in the phase of the definition of experiment. The technique helps researcher to come up with creative ideas for definition of experiment or improvement of the current one. The appropriate use in scientific research is illustrated below.

Substitute

- Can I substitute textile material?
- Can I substitute proposed measuring techniques?
- Can I use different standard for measurement?
- What happens if I change production parameters?
- Can different agents be used instead proposed?

Combine

- Which methods can be combined?
- Can I combine or recombine raw material for the production of fabrics?
- What can be combined to maximize research outcomes?
- What materials could be combined?

Adapt

- Is there a similar material that could be used instead?
- Which model/approach could be adopted for my research?
- What ideas outside field of textile engineering can I incorporate?
- Which measuring techniques can be adapted?

Magnify

- Can a set of samples be magnified or made larger?
- How can I add extra value to textile product?
- Can I increase a number of measurements?

Put to other use

- What else can this material be used for?
- Can this material be used for another purpose than it was originally intended for?
- Are there new ways to use this product in its current shape or form?
- Can I use idea in other industries/markets?

Eliminate

- How can I simplify experiment?
- Which segments in the production of material/clothing can be removed without altering its function?
- What feature can I understate or omit?

Rearrange

- What other arrangement might be better?
- Can I interchange components?
- Can I transpose positives and negatives?

2.2 Brainstorming

Brainstorming is a group or individual techniques intended for creative finding of a solution to a particular problem in a way that all participants contribute equally with ideas. It was designed by Alex Osborn and is often synonymous with multiple ideas-making techniques. Its purpose is to create an environment in which the group as a whole makes decisions, reducing the dominance of individuals and increasing group participation, especially those who would not participate from different backgrounds and who are shy. It encourages participants to produce as many ideas as possible without restriction that could hold back creativity and imagination. These ideas can be compared, expanded, combined, and prioritized. Using this method, topics and complex questions of great practical and cognitive importance can be solved in combination with methods such as teaching and research. Creative and innovative solutions are also encouraged, which, if absent, do not affect the success of the session. This technique has 4 basic rules designed to reduce possible inhibitions in a group and stimulate the generation of new ideas, namely: 1) quantity is desirable; 2) criticism is not allowed; 3) "crazy" ideas are welcome and 4) encouraging combining and refining ideas. Despite the good sides, some research has shown a loss of productivity using this technique since the results of group brainstorming were the same as individual work [6, 7].

In the doctoral research, this technique is optimal for use in first stages of research, specifically definition of topic and later, definition of experiment. Ideally, brainstorming group should consist of the doctoral candidate, mentor/co-mentor, professors who are tightly included into the research problem and eventually head of laboratory/studio with production facilities. In order to increase the quality of doctoral research, it would be also very wise to use this technique after the first results are obtained.

2.3 Breaking the rules

This method or technique is also known for generating new ideas. There are many cases when breaking rules promotes progression and many famous people were pushing the boundaries with this method. Good examples of this practice are Apple founders Steve Jobs and Steve Wozniak, who have revolutionized the computer industry. In addition, Tom Ford also defied the rules when he invented conveyor belts and encouraged mass production. Some empirical research suggests that rebellious individuals are more likely to be creative, while some sources mention that breaking the rules is the only way to achieve creativity in an environment where the tools for creativity are lacking. The premise is that a breach of policy for noble intentions can lead to positive problem-solving outcomes, although it can also have a negative relationship between a policy breach and the employee's work performance. Also, some sources suggest that organizations that tolerate rule violations are generally more innovative. Rule breaking is useful in entrepreneurship that requires innovative thinking and the development of new products and services that form the basis of organizations. [16].

Although not a well-known and well-used, this technique could be extremely helpful for doctoral research. The application of breaking the rules technique leads a researcher to challenge "good research" practices. Sometimes, qualitative research practices, especially with regard to focus groups and individual interviews, may be questionable to a certain manner. Therefore, this method is important to review the existing practice, to bring up new solutions and build up a ground for a new "good research practice". The method it to be used in the phase of experiment definition and could be valuable in interpreting results of doctoral research, as well as defining conclusions and guidelines for further research.

3. Conclusion

Creativity is important to effectively deal with professional and everyday challenges. Alongside with transversal skills it will be valued more than the specific knowledge traditionally taught in schools. However, with creativity a large database of knowledge is needed for new ideas to be born. Also, critical thinking has an important role in the field of creativity because creative process is a series of trials and errors and learning from mistakes. Magic formula for creative cycle doesn't exist but a lot can be done to become more creative and effective in solving problems in the engineering field. For example, there are many different creative thinking techniques that can be used for generating new ideas. But none of them are perfect, and alongside with, they all have some disadvantages. So, it would be best to combine them in order to get the most of them. For good results in scientific research it is also important to be focused, diligent and highly disciplined.

References

- [1] Stracenski Kalauz, M.; Salopek Čubrić, I.; Hudec, G.: Perception of soft skills in textile designers' education, *Global Journal on Humanities & Social Sciences*, 1 (2015), 1; 33-37, ISSN 2421-8030
- [2] Salopek Čubrić, I.; Čubrić, G.: ICT Tools in Education: Innovative Pedagogy and Assessment Methods for Grading Soft Skills, *Proceedings of 11th International Balkan Conference on Education and Science*

- IBES 2016 – The future of education and education for the future*, Prskalo, I.; Cvikić, L. (Ed.), October 2016, Faculty of Education, Zagreb (2016)
- [3] Salopek Čubrić, I.; Čubrić, G.: Creativity, Communication and Collaboration: Grading with Open Badges, *Proceedings of the 39th International Convention Mipro 2016*, Biljanović, P. (Ed.), 869-874, Rijeka:, ISBN: 978-953-233-087-8, Opatija, May, Croatian Society for Information and Communication Technology, Electronics and Microelectronics, Rijeka, (2016)
- [4] Salopek Čubrić, I.; Čubrić, G.: Kreativnost i tehnologija: osvrt na primjenu digitalnih bedževa, *Zbornik radova 9. znanstveno – stručnog savjetovanja Tekstilna znanost i gospodarstvo*, Glogar, M. I.; Grilec Kaurić, A. (Ed.), 122-125, ISBN 978-953-7105-73-0, Zagreb, January 2016, Sveučilište u Zagrebu Tekstilno – tehnološki fakultet, Zagreb (2016)
- [5] Joe. Y. E. Lau : *An introduction to critical thinking and creativity, Think more think better*, John Wiley & Sons, ISBN 978-0-470-19509-3 (2011)
- [6] Litcanu, M.: Brain-Writing Vs. Brainstorming Case Study For Power Engineering Education, *Procedia – Social and Behavioral Sciences*, **191** (2015), 387-390, ISSN 18770428
- [7] Linsey, J.S.: An Experimental Study Group Idea Generation Techniques: Understanding the Roles of Idea Representation and Viewing Methods, *Journal od Mechanical Design*, **133** (2011), 1-15 ISSN 10500472,
- [8] Aithal, P.S.; Shailashree, V.T.; Suresh Kumar, P.M.: Factors & Elemental Analysis of Six Thinking Hats Technique Using ABCD Framework, *International Journal of Advanced Trends in Engineering and Technology*, **1** (2016), 1, 85-95, ISSN: 2456-4664
- [9] Cassidy, T.D.: Mood boards: Current practice in learning and teaching strategies and students' understanding of the process, *International Journal of Fashion Design, Technology and Education*, **1** (2008), 1, 43-45, ISSN 17543266
- [10] Le Masson, P.; Hatchuel, A.; Weil, B.: Creativity and Design Reasoning: How C-K Theory Can Enhance Creative Design, *Proceedings of International conference on engineering design*, 1-12, Paris, France, August 2007, (2007)
- [11] Brown, D.; Kusiak, J.: Creative thinking techniques, *IRM Training Pty LTD.*, 2002-2005
- [12] Higgins, J.M.: *101 Creative Problem Solving Techniques: The Handbook of New Ideas for Business*, New Management Publishing Company, Inc., ISBN 1-883629-00-4, Florida, (1994)
- [13] Keong, Y.K.: *Budite kreativni*, Katarina Zrinski d.o.o., ISBN 978-953-236-151-3, Varaždin (2007)
- [14] Schroeder, Bernhard: *Simply brilliant: powerful techniques to unlock your creativity and spark new ideas*, Amacom, ISBN: 9780814437209, New York (2016)
- [15] Torrance, E. P.: *Guiding creative talent*, Muriwai Books, ISBN 9781789125009, Canada (2018)
- [16] Petrou, P.; Van Der Linden, D; Salcescu, O.C.: When Breaking the Rules Relates to Creativity: The Role of Creative Problem-Solving Demands and Organizational Constraints, *Journal of Creative Behaviour* (2018), 1-12, ISSN 2162-6057

Authors:

Assoc. Prof. Ivana SALOPEK ČUBRIĆ, PhD (corresponding author)
University of Zagreb Faculty of Textile Technology
Prilaz baruna Filipovića 28a, 10000 Zagreb, Croatia
Phone: +385 1 37 12 573

E-mail: ivana.salopek@unizg.ttf.hr

Ines KATIĆ KRIŽMANČIĆ, mag. ing. des text, Ph.D. student
Doctoral study Textile Science and Technology;
University of Zagreb Faculty of Textile Technology
Prilaz baruna Filipovića 28a, 10000 Zagreb, Croatia
Phone.: +385 91 22 94 964

E-mail: ikatickri@ttf.hr

Branka TOMIĆ, mag. ing. des. text., Ph.D. student
Doctoral study Textile Science and Technology
University of Zagreb Faculty of Textile Technology
Prilaz baruna Filipovića 28a, 10000 Zagreb, Croatia
Phone: +385 91 5666 665

E-mail: btomic@ttf.hr



PROFESSIONAL PAPERS

COMPARISON OF ANISOTROPIC PROPERTIES OF WOVEN FABRICS AND KNITTED FABRICS SUBJECTED TO TENSILE LOAD

Željko PENAVAL; Diana ŠIMIĆ PENAVAL & Tea JOVANOVIĆ

Abstract: *Theoretical analysis of the behavior of textile materials due to its anisotropic properties is very complex, and experimental testing of mechanical properties of knitted and woven fabrics is carried out. Measuring the stretch of knitted and woven fabrics when tensile forces act in different directions is an effective way to characterize anisotropy and structural changes of textiles. This paper analyzes the effect of anisotropy of knitted and woven fabrics on values of maximum force, maximum elongation, modulus of elasticity, work up to maximum force under action of tensile forces on samples that were cut at different angles to course direction of knitted fabrics, or to weft direction of woven fabrics. In experimental part of paper, samples of double weft knit fabric with 30 tex fineness of single cotton yarn and samples of cotton woven fabric in plain weave were tested. For different cutting angles of samples, curves of relationship between values of tensile forces and elongation to break were experimentally obtained. From the obtained force-elongation curves, modulus of elasticity was experimentally determined and work up to maximum force was calculated.*

Keywords: *anisotropy, modulus of elasticity, double weft knit fabric, cotton woven fabric, off-axes tensile behavior, maximum force*

1. Introduction

Anisotropy is one of the characteristics of knitted and woven fabrics that affects their physical and mechanical properties. The physical and mechanical properties of textile materials determine the extent of their end use in a variety of needs and applications. Therefore, it is important to know their properties at elongation under tensile force [1]. Tensile properties of textile under tensile force were investigated experimentally and theoretically. Initially, the research was mainly focused on the knitted and woven fabric behavior when forces acted in the main directions, i.e. in course and wale directions for the knitted fabrics, and the warp and weft direction for the woven fabrics [2]. Off-axis tensile behavior is also the most widespread process of testing and analyzing the physical and mechanical properties of knitted and woven fabrics. The tensile forces and strain values of textile products when changing the inclination angle of the action of tensile force are also important. It starts from the classical theory of elasticity with the assumption that knitted and woven fabrics are anisotropic materials of elastic properties with two planes of symmetry. At the beginning of elongation, the relationship between force and elongation is proportional. With further elongation, it begins to grow faster than the force. Consequently, the relation between force and elongation is no longer linear [3]. Due to the inherent nature of textiles, testing of woven fabric and knitted fabric samples is carried out in the laboratory under the action of tensile force in different directions.

The aim of this paper is to compare the experimentally obtained curves of the relation between the values of tensile forces and elongation to break for knitted and woven fabrics. The influence of anisotropy of knitted and woven fabrics on the values of maximal force, maximal elongation, work and modulus of elasticity is analyzed in the paper when axial tensile forces act on samples that are cut at different angles with respect to the course direction of the knitted fabrics, or the weft direction of woven fabrics. From the obtained force-elongation curves, modulus of elasticity was experimentally determined.

2. Theoretical foundations of knitted fabrics and woven fabrics

Woven and knitted fabrics are a special type of anisotropic materials, which are defined in terms of structural characteristics as orthotropic plates with two mutually perpendicular planes of elastic symmetry. Thus, these are elastic orthotropic materials, the planes of elastic symmetry are the planes of orthotropy, and their cross sections are the axis of orthotropy (x , y). In the biaxial woven fabric structure, two main directions are defined: longitudinal (in the warp direction, y -axis) and transverse (in the weft direction, x -axis), Figure 1a. The thickness of the woven fabric is negligible small compared to the other dimensions, so the deformation of the thickness is neglected. Knitted fabric is a textile product composed of wales and courses loops. Loops are formed by converting a newly fed yarn into new loops, i.e. by loop sinking, and the yarn is interloped with the next yarn, first forming half loops and then by interloping the next yarns loops are formed. Weft knitted fabrics are created by yarn feeding and loop formation across the needles, i.e. the yarn is fed horizontally as weft yarn in weaving,

and this yarn is bent into a wavy form, i.e. loops are sunk, and the yarn forms courses. The x-axis runs in the course direction, and y-axis runs in wale direction of the knitted fabric, Figure 1b.

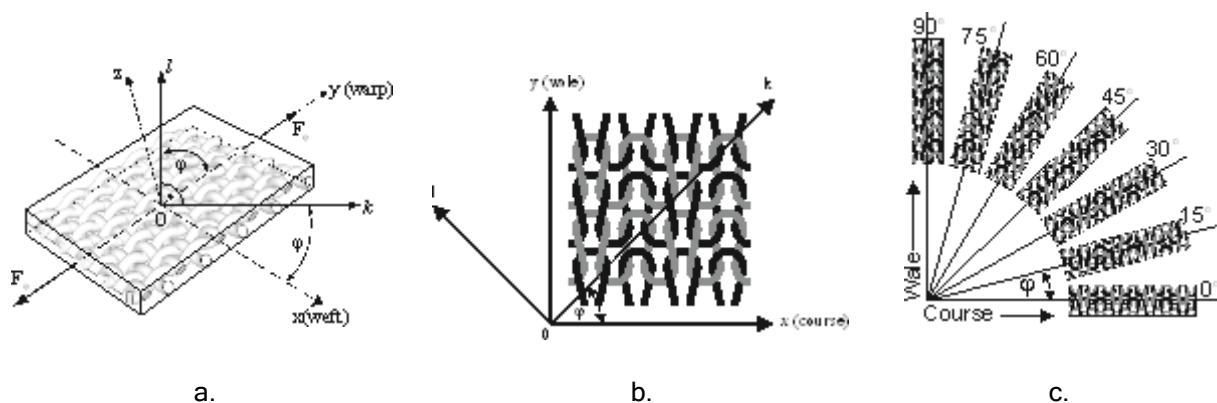

Figure 1: Element of an orthotropic plate: a) the plane stress state of the fabric sample, b) Double weft knit fabric structure, c) schematic representation of the directions (angles) of cutting knitted fabric samples

The stress (forces) and strain are shown by the functional relation, Eq. (1), which has a physical character and cannot be determined theoretically, but only by experimentally testing samples made of a particular material.

$$\sigma_{ij} = f(\varepsilon_{ij}) \quad , \quad \varepsilon_{ij} = f_1(\sigma_{ij}) \quad (1)$$

Determining and knowing the mechanical properties of woven fabrics and knitted fabrics is an important part of textile science. The experiments establish the relationship between forces and strain in the form of diagrams under certain conditions. The modulus of elasticity of the material E_φ is an important mechanical characteristic that is investigated within the area of elasticity.

3. Experimental testing

Experiment was carried out by measuring elongation of woven and knitted fabric and corresponding values of the tensile forces acting up to break of sample [4]. Tests were carried out on cotton woven fabric samples in plain weave, for warp and weft of the same yarn count ($T_t = 30 \text{ tex}$). Warp and weft yarn linear density is 22 cm^{-1} , mass per unit area is 150.3 g/m^2 and thickness is 0.318 mm . Woven fabrics samples were made on OMNIplus 800 tt air-jet loom Picanol. A double-bed circular knitting machine, gauge E17, was used to make knitted fabric samples. 8 knitting systems installed in needle bars of a diameter of 200 mm ($8 e^e$) were used, the cylinder working speed was 60 min^{-1} with a number of needles of 432×2 . A 30 tex single cotton yarn with optimum sinking depth was used to make knitted fabrics. Yarns were fed into the knitting zone with the same tensile forces amounting to $3 \pm 1 \text{ cN}$. Measured take-down force of knitted fabric made of mentioned yarn amounted to 23 cN/needle . The basic parameters of structure of analyzed knitted fabric are: loop density in course direction $D_h = 10.1$ (stitches/cm), loop density in wale direction $D_v = 13.2$ (stitches/cm), fabric thickness $t = 0.88$ (mm), mass per unit area $m = 246$ (g/m^2). For testing tensile properties, samples with standard dimensions $350 \times 50 \text{ mm}$ were cut, clamped into clamps of tensile tester at distance of $l_0 = 200 \text{ mm}$ and subjected to uniaxial tensile load. Pulling speed of clamps is $v = 100 \text{ mm/min}$ until sample breaks. Knitted fabric samples were cut in seven different directions: in course direction ($\varphi = 0^\circ$), in wale direction ($\varphi = 90^\circ$), and at angles of 15° , 30° , 45° , 60° , 75° according to course direction, Figure 1c. Woven fabric samples were cut in warp direction ($\varphi = 90^\circ$), weft direction ($\varphi = 0^\circ$), and at angles 15° , 30° , 45° , 60° , 75° to the weft. Direction of tensile force action during testing is always the same. Three tests were done for each mentioned cutting direction of sample. Tensile properties of all samples were tested according with standard ISO 13934-1:2013 using strip method for measuring fabric strength and its elongation on tensile strength tester Textechno, which registers data in form of diagrams. For different cutting angles of samples, curves of relationship between values of tensile forces and elongation to break were experimentally obtained. Before testing all specimens were conditioned under the conditions of standard. Yarn count of woven and knitted fabrics was determined by the gravimetric method according to standard ISO 2060:1994. Number of threads per unit length of woven fabric was determined according to standard ISO 7211-2:1984. The measurement method and the procedure by which the thickness of knitted fabrics and woven fabric was examined is defined by standard ISO 5084:1996. Loop density in the course and wale direction was determined per length of 1 cm . ASTM D8007-15 (2019) was used to determine wale and course counts of weft knitted fabrics per unit of length. Determination of the density of warp and weft threads of woven fabric was carried out using computer-controlled (stereo) microscope DinoLite.

3.1 Overview of test results

When tensile force F acts, the corresponding elongation ε is measured. The mean values of the measured results of the tensile force action F and the corresponding elongation ε for woven fabric samples cut at angles 0° , 15° , 30° , 45° , 60° , 75° and 90° with respect to the weft direction are shown at F - ε diagram, Figure 2a. The mean values of the measured results of the tensile force action F and the corresponding elongation ε for knitted fabric samples cut at angles 0° , 15° , 30° , 45° , 60° , 75° and 90° with respect to the course direction are shown at F - ε diagram, Figure 2b.

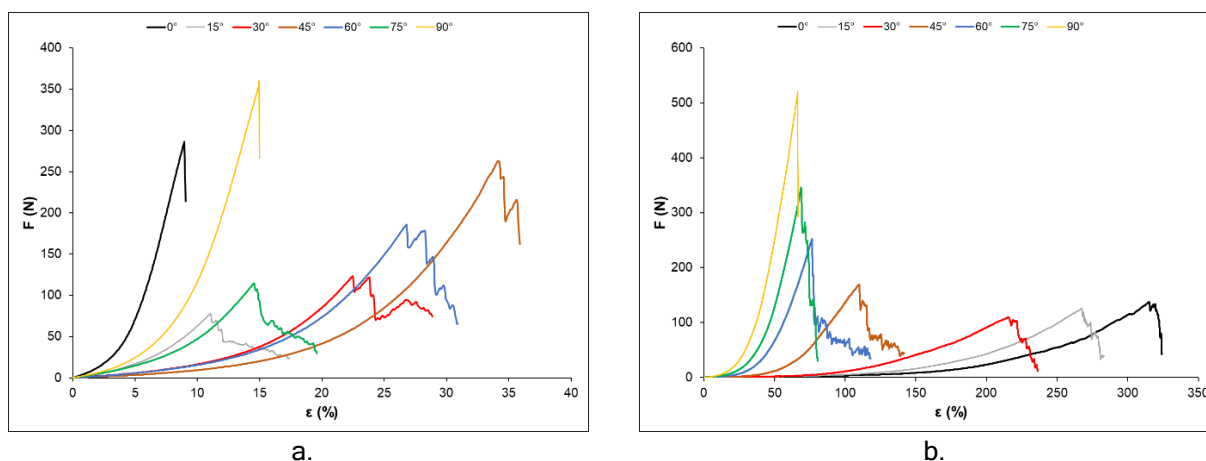

Figure 2: Diagram force - elongation (F - ε): a) woven fabric sample, b) knitted fabric sample

The dependence of values of maximum forces F_{max} of woven and knitted fabric on the cutting angle of samples is shown in Figure 3a and Table 1. The maximum force of knitted fabric has the highest value when samples are cut in wale direction ($\varphi=90^\circ$). With decreasing angle φ , values of the maximum force of knitted fabric decrease strongly and force has the lowest value when the samples were cut at an angle $\varphi = 30^\circ$ in relation to the course direction. For further decreasing angle to course direction ($\varphi=0^\circ$), the maximum force values of knitted fabric increase slightly. Value of maximum force of knitted fabric when samples are cut in wale direction is 3.78 times higher than the value of maximum force for samples cut in course direction.

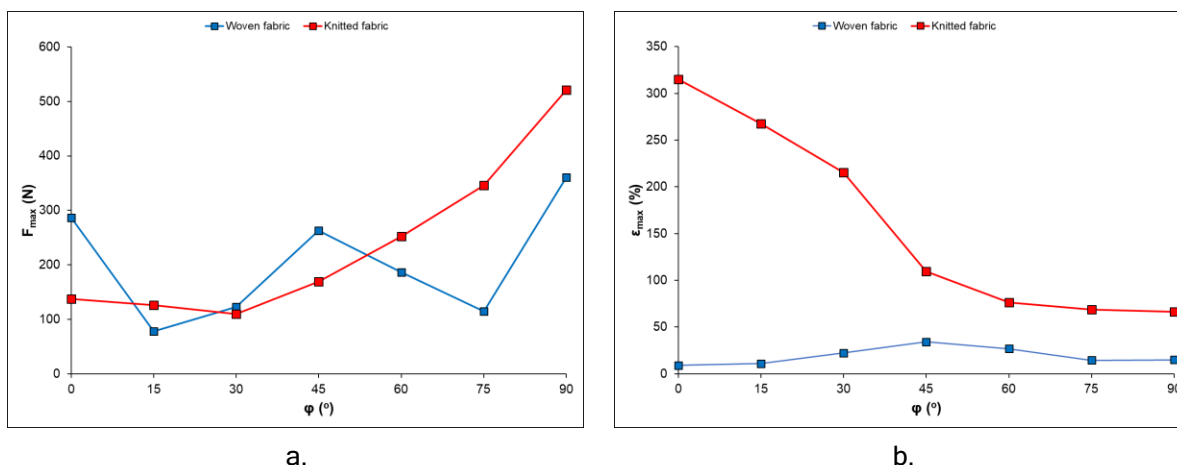

Figure 3: Dependency diagram: a) maximum force-cutting direction of sample (F_{max} - φ), b) maximum elongation- cutting direction of sample (ε_{max} - φ)

Woven fabric has the same warp and weft density, so diagram of values of maximum force is approximately symmetrical with respect to angle $\varphi=45^\circ$ when force acts in the diagonal direction, Figure 3a. Diagram has the shape of a "W". The values of the maximum force of woven fabric are given in Table 1. Maximum force of woven fabric has the highest values when the samples are cut in warp ($\varphi=90^\circ$) and weft ($\varphi=0^\circ$) direction. Values of maximum force slightly decrease from the weft direction, the lowest value is when force acts at an angle $\varphi=15^\circ$, then gradually increase to angle $\varphi=45^\circ$ and again decrease to angle $\varphi=75^\circ$, after which values of maximum force of woven fabric increase and the highest value they have when force acts in warp direction. Value of maximum force of woven fabric when samples are cut in warp direction is 1.26 times higher than the

value of maximum force for samples cut in weft direction. When knitted and woven fabric samples are cut at an angle $\varphi=90^\circ$ then maximum forces have the highest values and for knitted fabric maximum force is 1.45 times higher than maximum force for woven fabric. For angles of 15° , 60° and 75° , maximum forces of knitted fabric have higher values than maximum forces of woven fabric. For angles of 0° , 30° and 45° , maximum force of woven fabric has higher values than maximum force of knitted fabric. For angle $\varphi=0^\circ$, maximum force of woven fabric is 2.08 times higher than maximum force of knitted fabric. The largest difference in the value of maximum force of knitted and woven fabric is at angle of 75° , when force of knitted fabric is 3.01 times higher than force of woven fabric.

Corresponding mean values of maximum force F_{max} , maximum elongation ϵ_{max} , maximum work W_{max} , and initial modulus of elasticity E_φ for all cutting directions of knitted and fabric samples are shown in Table 1.

Table 1: Mean values of F_{max} , ϵ_{max} , W_{max} and initial modulus of elasticity E_φ for woven fabric and knitted fabric

Angle φ ($^\circ$)	Woven fabric WF30				Knitted fabric KF30			
	F_{max} (N)	ϵ_{max} (%)	W_{max} (Ncm)	E_φ (kPa)	F_{max} (N)	ϵ_{max} (%)	W_{max} (Ncm)	E_φ (kPa)
0	286,5	8,95	161,0	319.0	138,0	315,05	1803,7	0.71
15	78,0	11,05	58,9	152.1	126,2	267,50	1491,2	0.80
30	123,3	22,45	151,4	66.7	110,3	215,60	1255,7	0.94
45	262,7	34,10	407,8	42.9	169,1	109,75	945,9	1.49
60	186,1	26,80	257,9	67.9	252,6	76,45	949,8	3.33
75	114,9	14,55	107,0	153.3	345,8	68,85	1177,7	5.83
90	360,2	14,95	299,8	185.2	521,3	66,25	1863,5	6.89

Dependence of values of maximum elongations ϵ_{max} of woven and knitted fabric on the cutting angle of samples is shown in Figure 3b and Table 1. Maximum elongation of knitted fabric has the lowest value when samples are cut in wale direction ($\varphi=90^\circ$). Values of maximum elongation of knitted fabric increase slightly from wale direction to angle 60° . After this angle, values of maximum elongation of knitted fabric increase rapidly towards course direction ($\varphi=0^\circ$). Maximum elongation of knitted fabric has the highest value when samples are cut in course direction, and this elongation is 4.76 times higher than maximum elongation for samples cut in wale direction. For woven fabric, Figure 3b, values of maximum elongation are the smallest when force acts in weft direction ($\varphi=0^\circ$), then increase up to 45° where reaches the highest value and after that angle, values decrease slightly towards warp direction ($\varphi=90^\circ$) where maximum elongation reaches a bigger value than that in weft direction. The highest value of maximum elongation of woven fabric for samples cut at angle of 45° is 3.81 times higher than in weft direction and 2.29 times higher than in warp direction. For all cutting directions of samples, elongation values of knitted fabrics are significantly higher than elongation of woven fabrics. When samples are cut at an angle $\varphi=0^\circ$, value of maximum elongation of knitted fabric sample in course direction is 35.2 times higher than value of maximum elongation for woven fabric sample cut in weft direction. When samples are cut at an angle $\varphi=90^\circ$, value of maximum elongation of knitted fabric sample in wale direction is 4.43 times higher than maximum elongation for woven fabric sample cut in warp direction. Dependency diagram between values of maximum work W_{max} of woven and knitted fabric and cutting angle of samples is shown in Figure 4a, and their values are in Table 1.

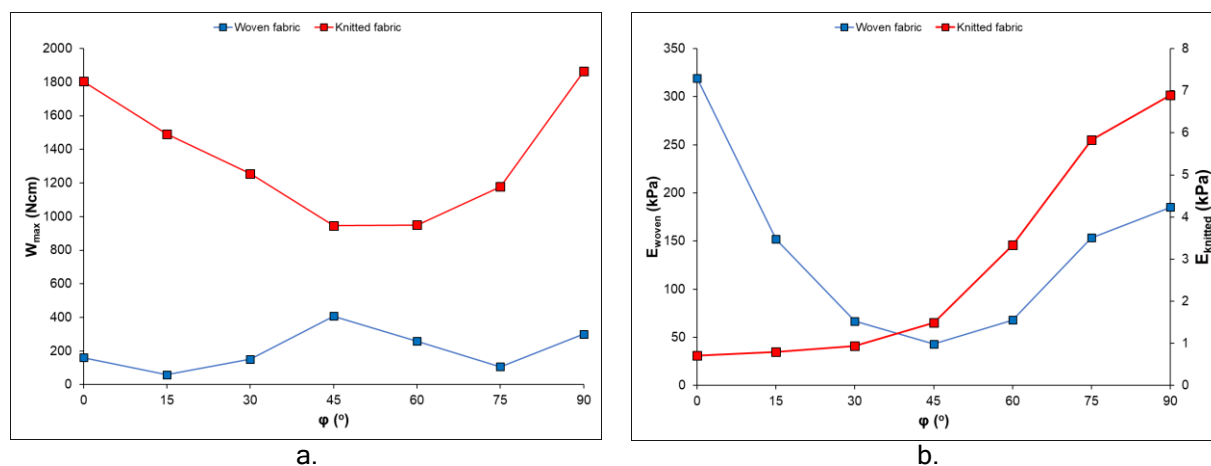

Figure 4: Dependency diagram: a) maximum work-cutting direction of sample ($W_{max}-\varphi$), b) initial modulus of elasticity-cutting direction of sample ($E_\varphi-\varphi$)

Maximum work W_{\max} was calculated to characterize properties of textiles in the region of higher deformation. From the results shown in Figure 4a, it can be seen that the highest values of maximum work for knitted fabric samples cut in course direction ($\varphi=0^\circ$) and in wale direction ($\varphi=90^\circ$) are approximately equal. Values of maximum work required to extend knitted fabric samples decrease when the samples are cut in the wale direction ($\varphi=90^\circ$) to an angle of 45° where they assume a minimum value. When direction of cutting samples changes from an angle of 45° to course direction ($\varphi=0^\circ$), values of maximum work increase abruptly. The highest value of maximum work is for knitted fabric samples cut in wale direction, and that work is 1.97 times higher than the lowest value of maximum work spent for samples cut at 45° . Knitted fabric samples cut at an angle of 45° are the weakest to take over tensile force. Samples cut in wale direction are most resistant to the action of tensile force.

For woven fabric, Figure 4a, values of maximum work slightly decrease from the weft direction $\varphi=0^\circ$, the lowest value is when samples are cut at an angle 15° , then gradually increase to angle 45° where maximum work reaches the highest value and again decrease to angle 75° , after which values of maximum work increase to warp direction $\varphi=90^\circ$. When woven fabric samples are cut at an angle 45° , the highest value of maximum work is 2.53 times higher with respect to weft direction 0° , and with respect to warp direction 90° it is 2.29 times higher. The highest maximum work is required to extend the fabric sample cut at an angle 45° . Cutting direction of woven and knitted fabric samples significantly affects their resistance to tensile force and on required values of spent work. When samples are cut at an angle 0° , value of maximum work spent on elongation of knitted fabric sample in course direction is 11.2 times higher than value of maximum work spent on elongation of woven fabric sample cut in weft direction. When samples are cut at an angle 90° , value of maximum work spent on elongation of knitted fabric sample in wale direction is 6.2 times higher than value of maximum work spent on elongation of woven fabric sample cut in warp direction. For all sample cutting directions, diagram of spent maximum work for elongation knitted fabric samples is above diagram of spent maximum work for elongation woven fabric samples.

3.2 Experimental values of initial modulus of elasticity

From the presented diagrams, Figure 2, the values of tensile force in the elastic range are used. We determined initial modulus of elasticity E_φ from a particular region on force – elongation curve ($\sigma - \varepsilon$) that is determined by monitoring the experimental data obtained from an experimental set-up with regression control chart [5, 6]. In this area there is a linear relation between force ie stress and elongation. The initial modulus of elasticity E_φ is defined as the slope of the stress-elongation curve in the linear region of elastic deformations where the Hooke's law applies to the uniaxial stress state:

$$E = \operatorname{tg}\alpha = \frac{\sigma}{\varepsilon} = \frac{F}{\varepsilon \cdot b \cdot d} [\text{Pa}] \quad (2)$$

where is b-width (mm), a d-thickness of knitted or woven fabric sample (mm).

Using the values of F and ε in the elastic range and expression (2), the mean values of initial modulus of elasticity E_φ are calculated with respect to the arbitrary cutting direction of knitted and woven fabric samples. Linear regression equations are applied to the stress-strain curves ($\sigma - \varepsilon$) in the elastic region, ie in the linear part. Slope of curve, ie direction coefficient of line, represents the modulus of elasticity E_φ . Values of initial modulus of elasticity are given in Table 1. Dependency diagram between experimentally obtained values of initial modulus of elasticity of woven and knitted fabric and cutting angle of samples is shown in Figure 4b.

Minimum values of initial modulus of elasticity of knitted fabric are for samples cut in the course direction 0° , then E_φ increases slightly to an angle of 45° after which values of initial modulus of elasticity increase sharply, and the highest value of modulus of elasticity is when knitted fabric samples are cut in wale direction 90° . Value of modulus of elasticity when samples are cut in wale direction is 9.70 times higher than the value of modulus of elasticity for samples cut in course direction.

Modulus of elasticity of woven fabric, Figure 4b, has the highest value when samples are cut in the weft direction 0° . As an angle φ increases, values of E_φ decrease sharply, the lowest value of E_φ occurs when samples are cut at an angle 45° with respect to weft direction. As an angle increases further, values of modulus of elasticity increase strongly to an angle in warp direction 90° . Value of E_φ when samples are cut in weft direction is 1.72 times higher than value of E_φ for samples cut in warp direction. The highest value of E_φ is for woven fabric samples cut in weft direction and it is 7.43 times higher than the smallest value of E_φ at an angle of 45° . When samples are cut at an angle 0° , value of E_φ of woven fabric sample in weft direction is 449.3 times higher than value of E_φ knitted fabric sample cut in course direction. When samples are cut at an angle 90° , value of E_φ of woven fabric sample in warp direction is 26.88 times higher than value of E_φ knitted fabric sample cut in wale direction.

4. Conclusion

Knitted and woven fabrics are special type of anisotropic material. Values of maximum force, longitudinal deformation, ie maximum elongation, initial modulus of elasticity, and maximum spent work are changing depending on cutting angle of knitted and woven fabric samples and are determined by experimental testing of samples for elongation in tensile tester. On the basis of experimental results, curves of the relation between values of tensile forces and associated elongation for different angles until break were obtained. From obtained force-elongation curves, initial modulus of elasticity was experimentally determined. The highest value of maximum force for all woven fabric samples is when samples are cut in warp direction 90°, then in weft direction 0°. This is explained by fact that at weaving, warp threads are more tense up than weft threads. Values of maximum force for tested samples that had been cut in other directions are less, because number of threads that are simultaneously affected in both clamps of tensile tester has been reduced. Maximum force of knitted fabric has the highest value, and the corresponding elongation has the smallest value when samples are cut in wale direction 90°. For knitted fabric samples that are cut in course direction, maximum force has the lowest value and elongation has the highest value. Maximum tensile force of knitted fabric is higher in wale direction than in course direction, because the loop is stressed over its two legs, and the loop density in the wale direction is higher than in the course direction ($D_v > D_h$), or approximately $D_v = 1.3D_h$. For all samples cutting directions, elongation values of knitted fabrics are significantly higher than the elongation values of woven fabrics. Knitted fabrics, unlike woven fabrics, are textile materials that require much higher maximum work to extend samples when the axial tensile force is applied. Thus, knitted fabrics are materials that provide much greater resistance to the action of axial tensile force than woven fabrics. Knitted fabric resistance to elongation is significantly higher in wale direction 90° than in course direction 0°. The highest work is required to extend knitted fabric samples that are cut in wale direction, then in course direction and the smallest work is required to extend sample at an angle 45°. For all sample cutting directions, values of modulus of elasticity of woven fabric are significantly higher than the values of modulus of elasticity of knitted fabric. Modulus of elasticity of knitted fabric has the lowest value when samples are cut in course direction and the highest value when samples are cut in wale direction. Diagram of modulus of elasticity for woven fabrics is symmetrical with respect to the angle of 45°.

References

- [1] Kovar, R., Gupta, B. S.: Study of the Anisotropic Nature of the Rupture Properties of a Plain Woven Fabric, *Textile Research Journal*, **79** (2009), pp. 506-516, ISSN 0040-5175
- [2] Zheng, J.: Measuring Technology of the Anisotropic Tensile Properties of Woven Fabrics, *Textile Research Journal*, **78** (2008) 12, pp. 1116-1123, ISSN 0040-5175
- [3] Shanahan, W.J., Postle, R.: A theoretical analysis of the tensile properties of plain-knitted fabrics. Part I: the load extension curve for fabric extension parallel to the courses, *Journal of the Textile Institute* (1974) **65**, pp. 200-212, ISSN 0040-5000
- [4] Bassett, R. J. et al.: Experiment Methods for Measuring Fabric Mechanical Properties: a Review and Analysis, *Textile Research Journal*, **69** (1999) 11, pp. 866-875, ISSN 0040-5175
- [5] Penava, Ž. et al.: Determination of the Elastic Constants of a Plain Woven Fabrics by Tensile Test in Various Directions, *FIBRES & TEXTILES in Eastern Europe*, **22** (2014) pp. 57-63, ISSN 1230-3666
- [6] Ozkul, B. , Karaoglan, D.: Regression control chart for determination of Young's modulus: A case study, *Scientific Research and Essays*, **6** (2011) pp. 6393-6403

Authors:

Prof. Željko PENAVAL, PhD. (corresponding author)
University of Zagreb, Faculty of Textile Technology, Department of Textile Design and Management
Prilaz baruna Filipovića 28a, HR-10000 Zagreb, Croatia
Phone: +(385) (1) 3712 576 Fax: +(385) (1) 3712 533 E-mail: zeljko.penava@ttf.hr

Prof. Diana ŠIMIĆ PENAVAL, PhD.
University of Zagreb, Faculty of Civil Engineering, Department of Engineering Mechanics
Fra Andrije Kačića-Miošića 26, HR-10000 Zagreb, Croatia
Phone: +(385) (1) 4639 426 Fax: +(385) (1) 4828 049 E-mail: dianas@grad.hr

Tea JOVANOVIĆ, mag. ing. aedif.
University of Zagreb, Faculty of Textile Technology, Department of Textile Design and Management
Prilaz baruna Filipovića 28a, HR-10000 Zagreb, Croatia
Phone: +(385) (1) 3712 576 Fax: +(385) (1) 3712 533

REFLECTING ON TRADITION THROUGH THE CREATION OF CONTEMPORARY TEXTILE OBJECT IN THE OLD-FASHIONED WAY

Branka TOMIĆ; Ivana SCHWARZ & Koraljka KOVAČ DUGANDŽIĆ

Abstract: *In today's modern day, hand weaving has almost fallen into oblivion. This skill traces its roots back to prehistoric times, when the invention of the weaving loom, in a certain way, revolutionized the production of textiles. This principle of the weaving process remained unchanged for thousands of years, until the industrial revolution that automated it and thus initiated the unstoppable development of the technological fabrication process. In addition, weaving used to play an important role in society. In the 21st century, marked by automation and mass production, artificial fabrics and market saturation, hand weaving is almost extinct. In Croatia, besides the above, the negative perception of the domestic textile industry in the society is also present. There is also insufficient interest in the exploitation of natural resources in the form of systematic collection of wool and its industrial processing. The aim of this research is to explore the possibility of creating a textile woven object of contemporary design in an old-fashioned way, thus stimulating reflection on tradition and preservation of cultural heritage and the untapped potential of wool.*

Keywords: *hand-weaving, weaving loom, wool, textile, spinning, tradition*

1. Introduction

In the age of weaving automation, fast trends, market saturation and expensive resources, hand-weaving is most often a hobby, while few individuals are fortunate enough to have it as a profession. Today, this skill is mostly taught in various courses, and there are hardly any more young adults who grew up with the loom. It is no longer necessary for girls to know how to weave, spin, knit, embroider, etc. to successfully marry. The knowledge of traditional weaving is slowly disappearing and is maintained by ethnologists, various folklore societies and enthusiasts.

2. History of hand-weaving

2.1. Prehistoric weaving

During its earliest history, textiles were produced on a small scale for personal use [1]. Braiding, netting and twining are believed to be the first textile fabrication techniques, and weaving appeared at the end of the 6th millennium BC [2, 3]. The process of weaving, as in the present day, was based on two systems of threads: vertical (warp) and horizontal (weft), and most likely weaving was done by manually scrolling through each thread of warp to produce a shed. The first mechanization of weaving was made possible by the invention of a heddle rod that moves all warp threads at once, creating a shed [4]. Vertical loom was through time replaced by a horizontal loom, which is still widely used today in numerous areas. Raw materials most commonly used during the Stone Age period were grass, tree bark and bast fibers, while animal fibers were probably used during Bronze Age, but there is no real evidence of this. Most popular of these fibers was sheep wool [2, 4].

2.2. Hand-weaving in 20th and 21st century

In Croatia, the loom has many names depending on the area, such as: *tkalački stan, krosna, tkalnica, tara, nared, vučín* and *prema* [5] (Figure 1). Some sources state that weaving in domestic handicrafts on the territory of former Yugoslavia was maintained until the World War II. In Croatia it began to decline at the end of the 19th century with disintegration of family collectives [6]. Hand-weaving is held today in textile schools, schools of applied arts and colleges and often in home crafts and occasional carpet factories (Persian and Mexican carpets) [7].



Figure 1: Woman (*tkalja*) weaving on the loom (source: Exhibition catalogue “The wonder of weaving”, MGC, 1988, pp. 94)

2.3 Wool

It was previously mentioned that from the earliest times textiles were made of vegetable and animal origin fibers, of which sheep wool was the most popular [4, 8]. Wool is a raw material that is farmed in almost every country in the world and in the past has had greater significance than it has today. In Croatia, there is sheep farming and wool as raw material, but in no area of the Republic of Croatia is wool farming the aim anymore and sheep herders are shearing for the sheep itself, not the wool [8, 9, 10].

Due to the lack of market interest, as well as the improper attitude of farmers towards wool and its poor qualitative features, it is uninteresting to the market. Because there is no systematic collection or industrial processing of wool, it is often thrown into meadows and pastures; in rivers, streams and seas, thus creating an environmental problem. In addition, large amount of wool is also burned [8, 9, 10].

2.4 Obtaining yarn and preparing for weaving

This part of the paper briefly describes the process of obtaining raw material for weaving in the past as well as the process of weaving in domestic crafts.

The wool is first sheared, sorted by quality, soaked and then washed in a mild solution of water and detergent, then rinsed and dried. This is followed by carding. In the past, this was done manually with special hackling boards, while in recent times wool was also carded on machines. The wool is then spun by hand using a distaff and a spindle or a spinning wheel and then rolled into skein. If necessary and desired, the yarn is used in natural wool color or dyed. When the yarn is finished, weaving preparation begins. The first, and most challenging, step is winding the warp which determines the width, density and length of the future fabric. During this process, it is very important that the warp is prepared with equal density and tension, and that the yarn threads are split into a cross. The warp is then mounted on the loom so that it is wound on the warp beam, and each thread is individually pulled through the shafts and reed. This phase is also important because it is then determined which fabric pattern will be woven. Eventually, the warp threads are tied to the cloth roll and can be woven using a prepared weft [11].

3. Experimental part

3.1 Inspiration

The collection presented in this paper is inspired by the folk costume of the Dinaric region of Croatia. In the past, the population of this area were mainly sheep herders, so traditional costumes were mostly made of

wool. A recognizable part of women's folk costume was the wool apron woven with the technique of “*klječanje*”, that is, by hand, finger picking the warp [12] (Figure 2).



Figure 2: a) Traditional Dinaric women's wool apron, b) detail from woollen cloth (*Photography: Branka Tomić*)

3.2 Art analysis

Folk costumes have regular, geometric and symmetrical patterns of various sizes that together form one whole. The reasons for this are the fact that at the loom with 2 or 4 shafts, the choice of weave is limited and the volume of the wool yarn prevents specimens to be too small. Also, stripes are an integral part of the motif. The aim of this paper, in addition to reviving the antique craft, is to modernize the motifs to make them more interesting and attractive to most people. In addition, an attempt was made to convert the classic antique textile item to another form. The possibilities to do this are endless. In addition to combining a variety of colorful or monochrome colors, it is possible to play with composition, asymmetry and motifs (Figure 3). Interesting patterns can also be obtained from various textures, making knots, omitting the weft and moving warp threads. Traditional items can also be transformed into different shapes and items.

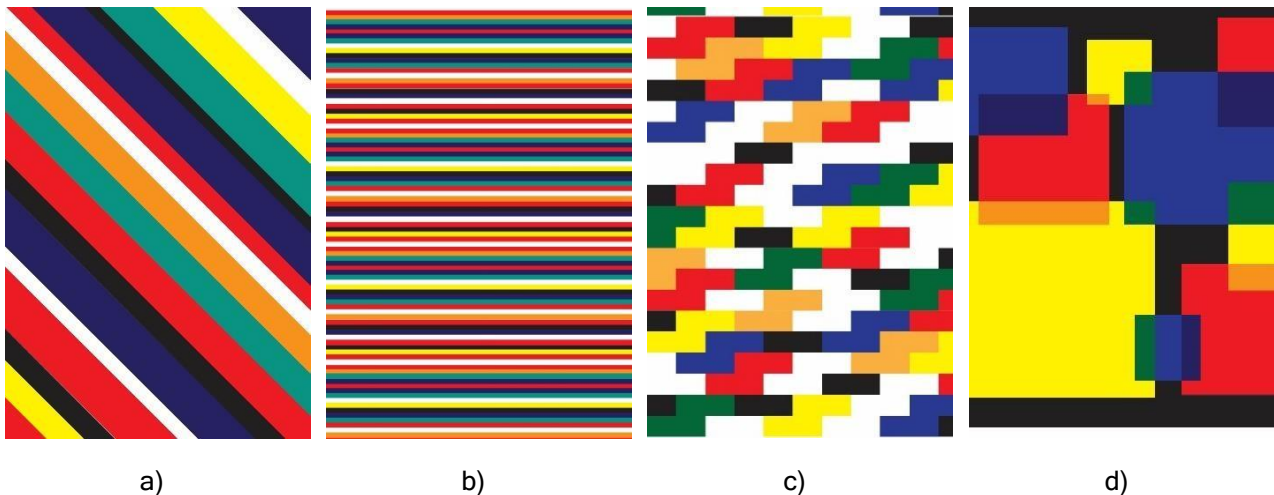

Figure 3: a), b), c), d): Author's pattern presentation (*Design: Branka Tomić*)

3.3 The process of making a textile object

Creating any textile object the old-fashioned way is not easy at the present day. Raw materials are difficult to access or are inaccessible, as well as long lasting processing procedure. In previous chapters it was mentioned that in Croatia there is practically no systematic collection and processing of wool. However,

procurement of raw materials is not impossible. Sheep herder should be contacted and wool could be processed as described in Chapter 2. It is a process that is time consuming and painstaking and is done at certain times of the year. In addition, washing wool the old-fashioned way, in a river or stream, is no longer possible due to environmental and potable water pollution. Hand carding with hackling boards is also a long-term task, and there aren't any mechanical wool carders in Croatia any more, as far as the author knows. There is also no spinning and dyeing plants/shops that would spin and dye the wool for handicrafts.

For all these reasons, wool for the production of this work was purchased in Bosnia and Herzegovina, where there are still shops involved in the purchase, processing and sale of wool. Prior to the start of the weaving process, several guidelines were laid down. Patterns with modified stripes were selected for making. The weaving pattern will be plain weave, and the technique is "klječanje" or finger picking warp for one model, and regular for the other (Figure 4). Items to be woven are bags modeled on an old-fashioned bag called "zovnica". They will be approximately 35x35 cm in size and will be made in the form of a backpack.



a)



b)

Figure 4: a) Weaving with „klječanje“ technique, b) regular weaving (Photography: Branka Tomić)

Finished fabric is folded and sewn into a bag (Figure 5). Interior is lined with cotton fabric and straps are made using a cotton string (Figure 6).



a)



b)

Figure 5: a), b): Finished fabric (Photography: Branka Tomić)



a)

b)

Figure 6: Readymade models of woven woolen backpacks (Photography: Branka Tomić; Model: Martina Kiš)

4. Conclusion

Hand-weaving is a skill that was appreciated and developed from prehistoric times until the World War II, and in some parts of Croatia until the end of the 19th century when the automation of the weaving process and the disintegration of family collectives began. Due to the advancement of technology and many other reasons, there is a fear of forgetting the hand-weaving skill, while the untapped potential of wool causes a lack of raw material as well as a major environmental problem. Hand-weaving is an indispensable part of tradition and cultural heritage, and it adds value to each crafted item through aspects of weaving skills, uniqueness, natural origin and time spent. Possibilities for creating original hand-woven items are endless, from the shape of the item to the colors, patterns and textures.

References

- [1] Ovčarić, F.; Tomić, B.: Rekonstrukcija proizvodnog procesa prikupljanja i obrade sirovina i bojadisanja vune u arheologiji, Rad za rektorovu nagradu, Zagreb: Filozofski fakultet, 2018., pp. 3-6
- [2] Bender Jørgensen, L., Grömer, K.: Arheologija tekstila -Suvremena dostignuća i novije metode, *Portal: godišnjak Hrvatskog restauratorskog zavoda*, (2012) 3, pp. 45-68, ISSN 1848-6681
- [3] Schoeser, M.: *Svijet tekstila Kratka povijest*, Golden marketing-Tehnička knjiga, ISBN 978-953-212-392-0 Zagreb, (2009.)
- [4] Grömer, K.: *The art of prehistoric textile making The development of craft traditions and clothing in Central Europe*, Natural History Museum Vienna, ISBN 978-3-902421-94-4, Vienna, (2016.)
- [5] Katunar, Lj., Somek-Machala, B., Vince-Pallua, J., Vinščak, T.: Etnološke karte Tradicijski oblici tkanja u Jugoslaviji, *Čarolija niti*, MGC, Zagreb, (1988), pp. 45-46
- [6] Radauš Ribarić, J.: O tekstilnom rukotvorstvu na tlu Jugoslavije kroz vjekove, *Čarolija niti*, MGC, Radauš Ribarić J., Rihtman Augustin D. (gl. ur.), Zagreb, 1988.; pp. 13-24
- [7] Kovačević, S.: *Ručno tkanje*, Prometej & Centar za kreativne alternative, ISBN 953-6460-37-8, Zagreb, (2003.)
- [8] Mioč, B.; Tomić, M.; Držaić, V.; Džaja, A.; Širić, I.: Mogućnosti korištenja ovčje vune u poljodjelstvu, *Hrvatski veterinarski vjesnik – Hrvatska veterinarska komora*, 25 (2017) 1-2, pp. 64-70
- [9] Držaić, V.; Kasap, A.; Širić, I.; Mioč, B.: Proizvodnja i postupci s vunom na području Republike Hrvatske, *Proceedings 53rd Croatian & 13th International Symposium on Agriculture*, Rozman, V.; Antunović, Z.

- (ur.), pp. 431-435, Vodice, Croatia, February 2018, Faculty of Agriculture, University Josip Juraj Strossmayer in Osijek, Osijek, (2018)
- [10] Dundović, A., Vinčić, A.: Vuna -zapostavljena sirovina u Hrvatskoj, *Tekstil*, 66 (2017.), 9-10; pp. 243-254, ISSN 0492-5882
- [11] Ethnological source
- [12] Ivanković, I., Šimunić, V.: *Hrvatske narodne nošnje*, Multigraf d.o.o., ISBN 953-6060-15-9, Zagreb, (2002.)

Authors:

Branka TOMIĆ, mag. ing. des. text.(corresponding author)
University of Zagreb, Faculty of Textile Technology
Prilaz baruna Filipovića 28, 10 000 Zagreb, Croatia
+(385) (91) 5666 665

E-mail: btomic@ttf.hr

Assist. Prof. Ivana SCHWARZ
University of Zagreb, Faculty of Textile Technology
Prilaz baruna Filipovića 28, 10 000 Zagreb, Croatia
+ (385) (1) 3715 574

E-mail: ivana.schwarz@ttf.unizg.hr

Assoc. prof. art. Koraljka KOVAČ DUGANDŽIĆ
University of Zagreb, Faculty of Textile Technology
Prilaz baruna Filipovića 28, 10 000 Zagreb, Croatia
+(385) (1) 3712 548

E-mail: koraljka.kovac@ttf.unizg.hr

A CREATIVE CONSIDERATION OF RAINWEAR

Dejla RAMIĆ & Belma GUTLIĆ

Abstract: *A raincoat generally suggests an expression from which we expect to have an emphasized purpose and to be functional. This research project attempts to open a chapter on the reconsideration of rainwear through a prototype. Although the idea of design leads to originality and a "new" product, the design is often an upgrade to existing information so that the products meet the needs of customers, opportunities and the market more effectively. Creating a whole new form of rainwear is a reaction to the commercial imperative and the need for designers to access a high level of discovery and creative resolution. In this respect, silhouettes, shapes, and potential "feeling" stimulate individuality by rehabilitating problematic figures which most often ignore the principles of aestheticism.*

Keywords: *raincoat, design, shapes, rainwear*

1. Introduction

A raincoat has traditionally a clearly defined function as a long coat made of waterproof material. A raincoat also represents the mental picture perceived by the observer when looking at the garment. The picture may differ with reference to the style of each individual. Although it has undergone a lot of stylistic changes over time, its close association with its historical background remains. The first raincoats appeared in China centuries ago and were made of bamboo fibers. However, they were popularized in Europe in the first half of the 19th century, after Scottish chemist Charles Mackintosh experimented with oil - a fatty byproduct of tar - when he made an accidental discovery that redefined dressing. By placing a layer of liquid rubber between two layers of fabric, the Macintosh created a new material that was water resistant but difficult and uncomfortable to wear. Then Thomas Burberry invented a gabardine - a breathable, weatherproof and durable fabric that revolutionized rainwear. Gabardine was patented in 1888. Burberry trench coat (a trench coat, a type of linen or woolen coat, which is practical in terms of substance and tailoring, so it can be used in different kinds of weather) was created during the World War One[1]. Significant advances in the field of rainwear have been made to develop, evolve and transform in line with invention of materials that will preserve the integrity of design to protect individuals against climate and environmental conditions. However, looking for a high level of design integrity nowadays when referring to the modern rainwear, it is anomalous for the consumer to have an assortment of garments that retain raincoat function but their appearance is often marginalized to find a the market place for basic necessities. This anomaly requires additional intervention, which establishes a clear understanding that it is particularly necessary to design this garment with a specific function. This thesis outlines the methodology adopted in the project explication. It also explains how certain methods have been applied within this approach. Accordingly, this practice-based research project intends to open up a reconsideration of rainwear by demonstrating how attractive design can be to a commercial interface with notions of consistent functional satisfaction with unattractive and conservative forms. The creative process of developing a prototype of a newly created rainwear garment from the discussion, involves the developmental processes of research, design and production. As a contextualizing document, this exegesis serves as an explanation and articulation of particular thinking that is integral to the development of the work. It offers a background narrative that positions the researcher and highlights the importance of the research considering the current situation regarding the design of rain clothing (in a fashion context).

2. Creative design solution methodology

It is often assumed that the idea of design starts with sketching. According to the location of the problem, this procedure was a prerequisite. Conceptualization emerged as a form of mental visualization. Visualization is a substance that we bring into the internal, dialogic process of drawing. The first design that appears on paper contains suggestions of shapes and details. It's a time of thinking through drawing without limiting the potential with a high level of judgment. Spontaneous and fast production means that the process of mental dialogue has begun. During this process, areas of design weakness become apparent and negotiation of design aspects to re-establish the power of ideas follows. This form of renegotiation becomes a real design process. At this point drawing and thinking interact with each other in dialogue. Once the process of thinking has resulted in a "concrete" visualization through the drawing process, it exits the interior space and seeks expert advice so that the technical elements as an integral part of the design can be taken into account [2]. Experience in outerwear design does not provide much without experience in the specialized field of rainwear.

Targeted design interventions, introduction of innovation in the field of rainwear design for creation of a collection that will present individuality, yet surpass the offer with more attractive designs than the codes already identified, is a challenge that has required considerable initial awareness. We get to the point where research design gets retroactively placed into an external framework from where the collaborative aspect of the design process begins. Fashion designer technical research sources, outer elements required for the final production (such as fabrication and technical advice) are obtained and sampled before the design process proceeds. Traditionally, sources are found before designing process because the data collected is a fundamental factor affecting the initial thinking about the process. During the design development phase, source thinking and initial concepts comply with a more detailed drawing process. Drawing helps the designer to find unintended consequences. The information that appears during the design process cannot be foreseen before undertaking a project activity or assignment. Ideas become a direction and the designer will try different configurations of the new version uplifting it to a higher level [3]. Further ideas refinement enabled the design finalization. Central issues related to consistency, integrity and internal coherence were discussed at this design stage. Slight changes were made as a dialogue focused on more detailed technical - aesthetic issues.



Figure 1: Fashion drawings

After a series of drawings of a potential design, a limited number were brought to the second stage of development. The approach became more technical as details were finely tuned with regard to the cutting and construction elements required for the next phase of the project. The outcome of this process was the making of a technical drawing.

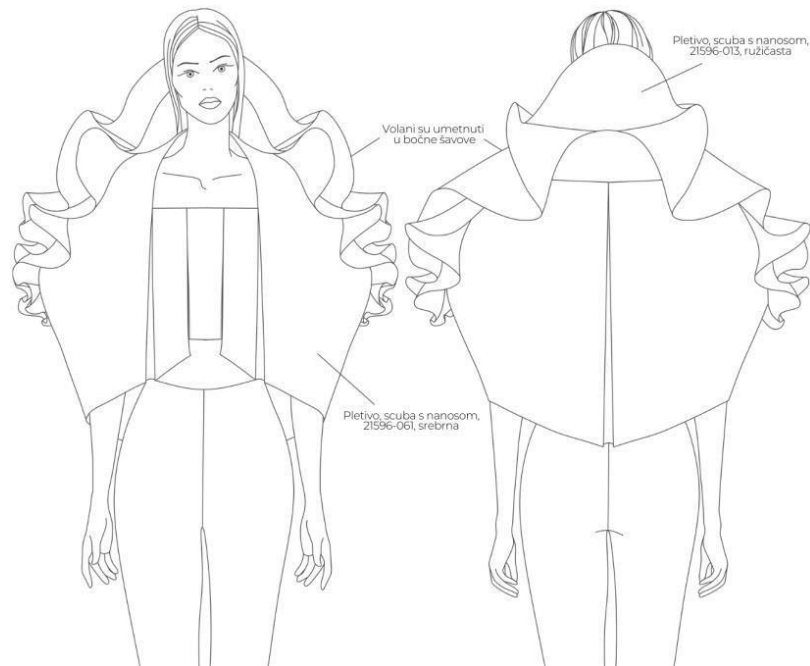

Figure 2: Technical drawing

The development phase is crucial and requires time to observe how the clothing moves and adheres to the body. It is also used for the estimation of the design details functionality. The design chosen required a two-dimensional cutting pattern where the measurements created a silhouette by modeling the basic pattern of the cape [4]. The dialogic process that has been developed during drawing continued as a method of evaluating and testing movement through this phase of work. In this regard, design is refined by moving back and forth between concept and outcome, testing ideas and refining them in incremental steps. The outcome, then, is not a fixed manifestation of a pre-resolved problem. Its three-dimensionality is allowed, which offers consideration in ways that drawing could not. Each new outcome had become the bearer of all the accumulated information and problem solving until it reached the stage where it was ready for its final cut (in the fabric selected for the final garment). This cut became the first pattern. The designer has to decide through his/her creative process which fabrics are appropriate and currently available for the particular design genre. Accordingly, this project began by putting the design concept on paper at its earlier stage having in mind the type of the end consumer. If there had been a specific company or an existing label, the target market would have been already defined. However, it was a work on a solo project with no predefined context. Searching for fabric was an aspect of the procurement phase that involved visiting fabric wholesalers to review the textile assortment in stock. Textile houses usually have their own special types of fabrics and, in general, designers can preview the available range of the upcoming season fabric just before designing process. Type of textiles required for this project, were not limited by season, only by availability. After several attempts to select the most convenient and most accessible ones, two samples of waterproof materials were selected considered the most suitable. Although the initial choices were relatively conservative, a wider selection of patterned fabric was also selected to be retained for later consideration. Through this process valuable informations were obtained from textile representatives who were able to answer questions and offer advice.

3. Results and discussion

This project can be considered as a social practice because it deals with the issue of identity as well as design in the process of rethinking and reformulation. However, structurally, the approach oscillates between creative processes, data collection and evaluation. Design is the ability to imagine the non-existing, an innovation to make a concrete form a new purposeful addition in real time [5]. Why don't designers produce rainwear that maintains both functionality and an aesthetic dimension? By initially positioning the consumers, this issue evolved making research active rather than analytical. By asking the question, one tries to understand the context in which the solution can be found. A market survey was carried out in this regard. In doing so, an assessment was conducted on the prevalence of rain clothing made using a less conservative approach. To facilitate this, a plan was made to identify how rainwear could be categorized in the market, proving that offer is an effective for protection even without a wide range of design interventions or even none. Although the project's main purpose was the inspection of waterproof materials, it should be emphasized that the prototype

of the raincoat was made of plain cotton which at the same time was used for the inspection of consumers' response to the final form.



a.



b.

Figure 3: Materialized raincoat prototype a, b

The market is predominantly filled with raincoats designed as an active dry-keeping sportswear yet outlined as a unique in a modern environment. This established code offers a certain level of safety. If one steps inside in a particular situation, one can quickly feel a sense of judgment and alienation. It can be argued that knowing or recognizing the appropriate codes allows the individual a sense of belonging. In this regard, dressing can be considered as a form of communication.

Fashion is the language through the system of signs it sets. But the narratives around the design, the inspirational quotes, are often foreign to the experience.



Figure 4: Fashion photography

The problem also arises with the inability of an individual to send an imagined message of what he/she is wearing due to the lack of choice in the market. Interest in clothing as a means of communicating identity, location, and even status, has become an integral part of assimilating research. Sign systems of fashion manifest their functional mechanisms as sources of meaning and value. If one accepts that "meaning and value" are inherent in dress codes, it is easy to see how transgressions can be considered devastating. To interact with the social and physical environment, one must read the codes and adopt them as a form of assimilation [6]. However, in doing so, one often refuses to reject certain values that have existed and developed as important. This ambiguity ultimately allows for achievements that are happening in a new sense of self-will. Extending this discussion, it also explains how certain methods have been applied within this approach. The description of the methodology enables the reader to evaluate the validity of the research design. However, established methodologies in the design discipline are not always placed in a process of reflexive practice where the outcome of the investigation, as well as the process, cannot be easily predicted. Methods should not prescribe problems; rather, problems must prescribe methods. The design researcher should make practical and appropriate interventions in real situations. Methods can be perceived as acting within a different research design that contains certain general principles. In a research project, the methodology provides a possibility to find a way of research engagement and provides the means to do so by putting what has been done in a comprehensive research context. In doing so, it also provides an explanation of choices, reasons and results [7]. This research project can be understood as a research design tailored to the nature of creative rethinking. Thus the research design is constructed to be useful in negotiating productive oscillations between reflexive practice and feedback. Research design in that view becomes action research.

4. Conclusion

The broader conceptual base of the research project is placed in a commercial context. As such, it responds to existing commercial principles by conducting research that did not go through cycles of planning, action, observation and deliberation in a systematic and documented manner. It can be understood as an exploratory design tailored to fit the nature of creative rethinking of design that has been considered a fundamental aspect of rainwear design. Creating new designs that deviate from established norms has created a prototype of a garment, extremely wearable with a dose of eclecticism, emphasizing the aesthetic principles of design discovery. The nature of the design process was partly determined by the need to resolve existing issues before the next phase began, thereby achieving the desired resolution level. It is integrated and

inseparable from all these stages, a cognitive substrate followed by a technical - aesthetic procedure. In this sense, research has become an archive of study history, but also a means of transferring knowledge and articulation.

References

- [1] Steed, J.; Stevenson, F.: *Sourcing ideas*,AVA Publishing SA, ISBN 978-2-94041163, Switzerland, (2012)
- [2] Wikstrom, A. *A design process based on visualization*, Mälardalen University, Västerås, ISBN 978-91-86135-85-0, Sweden,(2010)
- [3] Mäkelä, M. et al.: Drawing as a research tool: Making and understanding in art and design practice, *Studies in Material Thinking*, (2014) **10**,pp.3-12, ISSN 1177-6234
- [4] Ujević, D. et al.: *Tehnike konstruiranja i modeliranja odjeće*, Tekstilno- tehnološki fakultet Sveučilišta u Zagrebu, Zrinski d.d., Čakovec, ISBN 978-953-7105, Zagreb,(2010)
- [5] Bukve, O.: Design of Research Projects, *Available from* https://doi.org/10.1007/978-3-030-03979-0_5
- [6] Wiana, W.: Fashion as a Language of Non Verbal Communication, *Available from* <https://www.researchgate.net/publication/318041220>
- [7] Cvitan-Černelić, M. et al.: *Moda: povijest, sociologija i teorija mode*, Školska knjiga, Zagreb,(2002)

Authors:

Doc.mr. Dejlja RAMIĆ (corresponding author)
Univerzitet u Bihaću Tehnički fakultet Bihać
Ulica dr. Irfana Ljubijankića bb 77000 Bihać Bosna i Hercegovina
Phone: +(387) 61 532 515 Fax:+(387) 226 273

E-mail:dejlaramic.tfb@gmail.com

Belma GUTLIĆ
Univerzitet u Bihaću Tehnički fakultet Bihać
Ulica dr. Irfana Ljubijankića bb 77000 Bihać Bosna i Hercegovina
Phone: +(387) 62 875 516

E-mail: belma-gutlic@hotmail.com

STUDY CASE – RECONSTRUCTION OF MEN'S CLOTHING FROM THE SECOND HALF OF THE 16TH CENTURY

Emma IVANKOVIĆ; Katarina Nina SIMONČIČ & Irena ŠABARIĆ

Abstract: *The garments of the common people of the Renaissance period haven't been treated with the same care as the fashion of the aristocrats. The visual representations don't show us a clear form in the design of the objects presented, whereas by not preserving the clothes of the ordinary people brings the problem in the documenting of clothing construction. Therefore, further research is more complex. This paper aims to show the connections, but also the differences, in the dressing of the lower and higher classes in the Renaissance by interpreting clothing items in the Giovanni Battista Moroni's portrait „The Tailor“ (1565 – 1570). The book by British clothing historian and costume designer Janet Arnold "Patterns of Fashion: The Cut and Construction of Clothes for Men and Women 1560-1620" (1985) served as a primary source in exploring the construction and method of obtaining the silhouette. Comparing the clothing shapes of certain objects with the Moroni's portrait, one can notice the similarity between the garments of the aristocrats and the tailor.*

Keywords: *Renaissance, fashion, form, reconstruction, interpretation, clothing.*

1. Introduction

Giovanni Battista Moroni's portraits are fashion and textile treasures, showing the quality of the fabrics and details of the garment's construction in perfect details, as well as showcasing the rapid changes in fashion in the 16th century. Among Moroni's portraits of nobles and aristocrats, the portrayal of wealthy tailor indicates the range of the social status of Moroni's sitters and his interest in functional items, in this case, scissors, as well as luxury. „The Tailor“, the most famous Moroni's painting made between 1565 and 1570s, can be found in the National Gallery in London since the 19th century. It is considered the earliest portrait of a craftsman, although it is uncertain whether it is a real tailor, a fabric cutter, a fabric trader or it's just a display of a sitter. The tailor looks directly at the viewer, with scissors in hands as he prepares to cut a black cloth which is already marked with white chalk.

2. Information

In the late 15th century, influenced by foreign styles, sometimes French and German, but mostly Spanish, Italian fashion was changing rapidly. The tailor's clothes are modern and expensive, but made of wool rather than the luxurious silk fabric worn by Moroni's socially elevated subjects [1]. The soft doublet with high collar is characteristic of the period when the portrait was created. From the 1540s to the 1575, men's fashion in Italy underwent a slow transformation, borrowing elements from Flemish and Spanish fashion. In the mid-16th century, the neckline gradually closed, creating a tall and solid collar of Spanish character. The Spanish influence on doublet length and narrow sleeves can also be seen. The slits found throughout the upper garment on the portrait do not allow the display of chemise or any other lining that was in style with the new Renaissance fashion. Due to the slight folds into his abdomen, it cannot be said that the tailor's doublet was enhanced by busk, although it has the form known as „peascod belly“ due to the bulging portion of the abdomen. The front of the garment is single-breasted with thirteen buttons, one on the collar area, while the others are positioned centrally on the edge of the doublet, assuming another button is below the belt, hidden. To reduce the rough geometric outline of the garment, a ruff appeared in 1555 in the area of the neck and wrist. „Trunk hose“ in different shapes were distinguished by innovation, built-in pockets that carried coins, wiped, sweets, etc. Slashed and puffed hose, made of wool or silk, was fashionable in Spain, while in France they were so wide as to conceal weapons, until Henry II. restricted their volume in 1553 [2].

Codpiece, slits and full „hose“ with visible lining are German and Swiss origin, which caused a change in the fashion of Spain, and thus of Italy. In all countries except Italy, the hose kept the codpiece pocket until about 1580, which placed an emphasis on the crotch. It's possible this may originally have derived from the small gusset¹ filling in the crotch of military costume, rendered indispensable by the coming of plate armor [2].

¹ Gusset = a usually diamond-shaped or triangular insert in a seam (as of a sleeve, pocketbook, or shoe upper) to provide expansion or reinforcement

3. Experimention

3.1 Moodboard and modeled basic patterns

Due to the different representations of doublet and hose during the 16th century (and beginning of the 17th century) within the attached moodboard (Figure 1), Assist. Prof. Irena Šabarić, Ph.D. has proposed a book by Janet Arnold „Patterns of fashion 1560 – 1620“. The pattern of the tailor's top garment is shown in the book and it's used to model the basic pattern of a men's jacket.



Figure 1: Moodboard

The basic design of the men's jacket was made according to the book by Darko Ujević, Dubravko Rogale and Marijan Hrantinski „Tehnike konstruiranja i modeliranja odjeće“ [3]. The doublet is made of unbleached linen, however, the front and back are thickened by interfacing for firmer shape and trying to create a „peascod belly“ silhouette (Figure 2: a, b).

Table 1: Body measurements for construction of men's jacket

Body height	183 cm
Chest girth	92 cm
Chest width	40 cm
Back width	43 cm
Back waist length	50 cm
Neck girth	39 cm
Neckline	7,6 cm
Waist girth	77,5 cm
Length of pattern	63 cm

The sleeve is designed on the basic sleeve pattern of a men's hooded sports jacket, it's also made according to Darko Ujević's book [3]. While the crescent-shaped insert at the top of the sleeves is designed freely (Figure 2: f). The arch of the top of the sleeve was extended by 4 cm on either side (+ 1 cm for the hem) and extended

by 5 cm (+ 1 cm for the hem) (Figure 2: c, d). On the forearm of the sleeve is thickened by interfacing and there are no slits on this area.

Table 2: Body measurements for construction of a sleeve

Sleeve length	65 cm
Wrist circumference	25 cm
Shoulder length	47 cm
Armhole length	17,5 cm
Scye depth	28,5 cm
Armscye girth	57,7 cm
Armscye height	43,2 cm
Sleeve cap height	16,44 cm
Sleeve opening circumference	34 cm
Shoulder slope	27,9 cm

The entire garment contains 362 slashes (excluding slashes for buttons) made with a sewing machine, with a technique that is made for making holes for buttons, that's eventually slits (Figure 3). For securing the slashes of opening there are 2 172 knots. The number of buttons on the front of the doublet is the same as in Moroni's portrait of the tailor, which are 13.

The collar was made by modeling the pattern of standing, i.e. Russian collar [3]. Larger collar height dimensions were taken to resemble the portrait as much as possible (Figure 2: e). There are 8 slashes on the collar, not counting the buttonhole, and it's thickened by interfacing.

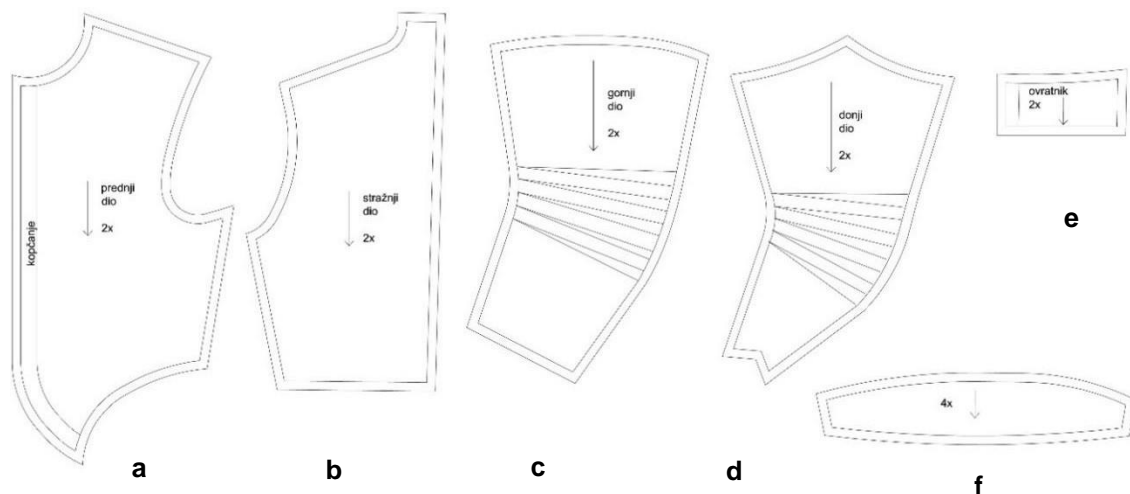

Figure 2: Modeled patterns of the garment: a) front, b) back, c) upper sleeve, d) lower sleeve, e) collar, f) crescent-shaped insert



Figure 3: Making of slashes on the sleeve

The basic pattern of men's trousers [3] is modeled on the design of *Grimsthorpe and Drummond Castle Trust Ltd, on loan to the V&A Museum, London* [1]. Although the year of displayed trousers is not the same as the year of the portrait, it was taken as an example because of the similarity in the shape of the trousers.

Table 3: Body measurements for construction of men's trousers

Waist girth	76 cm
Hip girth	96 cm
Thigh girth ²	48 cm
Trouser length	108 cm
Crotch length	84,5 cm
Seat depth	23,5 cm
Front width of trousers	28 cm
Back width of trousers	31,5 cm
Ankle girth	34 cm
Front width of seat	5,8 cm
Back width of seat	14,2 cm
Seat width	20 cm

The trousers are made of two parts, the inner and the outer part. One-quarter of the inner's trousers, i.e. half of one leg is 130 cm long. The pleats at the top of the trousers are made like on the example of a pattern in Arnold's book, only adapted to the body measurements of the male model (Figure 4: a, c). Pleats on the lower part of the trousers are achieved by shirring the fabric and adjusting to the measurements of the thigh. On the hose, there are 16 slits, 35 cm long, forming strips 5 cm wide.

The outer trousers are slightly shirred on the top and the bottom to create fullness and the gusset on the front holds the form of puffiness (Figure 4: d). The waistband is sewn on the outer and inner trousers on the area of the waist and thigh. (Figure 4: b).



Figure 4: Modeled patterns of the garment: a) second part of inner trousers, front, b) belt, c) one out of two parts of inner trousers, back, d) outer trousers

² Thigh girth = average circumference of upper leg

4. Results

By modeling the basic pattern of men's jacket and trousers using the book by Darko Ujević, Dubravko Rogale and Marijan Hrantinski „Tehnike konstruiranja i modeliranja odjeće“, and with the help of Janet Arnold's book „Patterns of fashion 1560 – 1620“, a two-part garment was made, i.e. three-part if we count the trousers as two separate parts (Figure 5).

The scope of the trousers, known as trunk hose, was achieved by the two-layered linen and the weight of the material that was not stiffened by the interfacing. The represented elements of the slits which are shown in Giovanni Battista Moroni's portrait „The Tailor“, which are also not marked in the patterns of Janet Arnold, created a discreet insight into the interior of the garment. Due to the use of fundamental material such as linen, the magnificence, and experience of the garment's richness can be only sensed in terms of texture, shine, and tenderness of the materials once used.

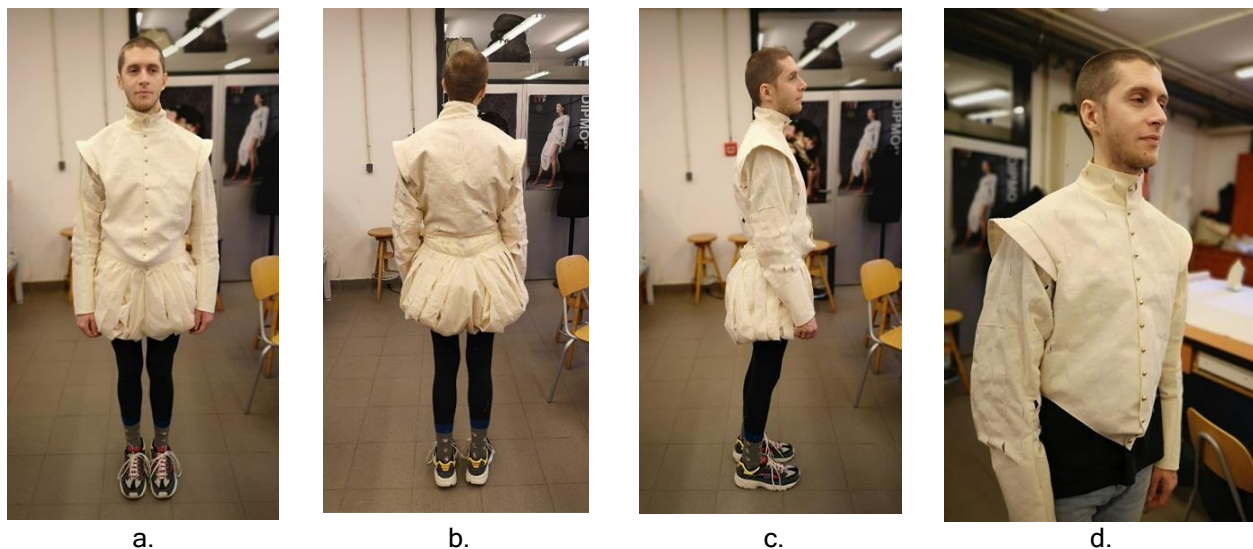

Figure 5: Reconstruction of the garment, a) front, b) back, c) profile, d) close up of doublet

5. Conclusion

Exploring the period and comparing Renaissance fashion with Giovanni Battista Moroni's portrait (1565 – 1570), a whole tailor's garment was reconstructed with all the details. As the identity of the person in the portrait is unknown, nor the accuracy of his profession, there is a lack of material information with an accurate description of the garment. Without looking at Janet Arnold's book „Patterns of Fashion: The Cut and Construction of Men's and Women's Clothing 1560-1620“ it would be impossible to study and make the details that are crucial in making the entire garment. The pattern of a similar garment made it easier to model the basic pattern of the trousers by displaying gussets on the front of the trousers without which „the trunk hose“ would not hold its shape. While the pattern of the tailor's doublet made it easier to think about the shape and parts of the sleeve because of the unclear portrayal of the portrait itself. The number of slits on the tailor's doublet is much higher than on the reinterpretation of the jacket, which shows a great desire and attention to "decorate" garments for aesthetic purposes of the time. Surprising realization in the manufacture of trunk hose is in a large amount of material, the width of one leg is 2.6 m, which in total is more than 5 m of material for inner trousers only (Figure 5). The garments that were common during the Renaissance are rich in detail and therefore lavish, as opposed to the clothes on the chosen portrait. Considering that there were no sewing machines at that time, making items with so much detail required a lot of knowledge and hours of manual labor.

References:

- [1] Arnold, J.: *Patterns of Fashion: the cut and construction of clothes for men and women 1560–1620*, MacMillan, 978-033-3382-84-4, London, (1985), 3 – 75.
- [2] Boucher, F.: *20,000 Years of Fashion: The History of Costume and Personal Adornment*, Harry N. Abrams, INC., 978-810-9005-64-5, New York (1967), 228 - 240.
- [3] Ujević, D., et al: *Tehnike konstruiranja i modeliranja odjeće: Treće dopunjeno i prošireno izdanje*, ZRINSKI d.d., 978-953-7105-36-5, Čakovec, (2010), 111 – 235.

Authors:

Univ. bacc. ing. des. text. Emma IVANKOVIĆ (corresponding author)
University of Zagreb Faculty of Textile Technology, Department of Fashion Design
Prilaz baruna Filipovića 28a, HR-10000 Zagreb
Phone: +(385) 99 462 1368

E-mail: eivankovi@ttf.hr

Dr. sc. Katarina Nina SIMONČIĆ
University of Zagreb Faculty of Textile Technology, Department of Fashion Design
Prilaz baruna Filipovića 28a, HR-10000 Zagreb
Phone: +(385) (1) 3712 564

E-mail: katarina.nina.simoncic@ttf.hr

Doc. dr. sc. Irena ŠABARIĆ,
University of Zagreb Faculty of Textile Technology, Department of Fashion Design
Prilaz baruna Filipovića 28a, HR-10000 Zagreb
Phone: + (385) (1) 3712 554

E-mail: irena.sabarc@ttf.hr

THE REVIVAL OF GOLD THREAD EMBROIDERY IN THE CONCEPT OF SLOW FASHION

Irena ŠABARIĆ; Franka KARIN & Doriana DUIĆ

Abstract: *The subject of this paper is the technique of gold thread embroidery and its implementation in contemporary dress with the goal of reviving this craft. Gold thread embroidery is a type of manual embroidery with golden thread that has been a tradition since the beginning of the 20th century to the present day. Traditional clothing, its preservation and traditional approaches in manufacturing are dying out due to fast fashion which imposes fast-paced changes of fashion trends. Slow fashion can be associated with the cultivation of old crafts and artisanal production with the goal of preserving tradition and cultural value of products. These are also the guidelines towards sustainability of the production and the environment and raising ecological and ethical awareness. The first part of the paper describes the techniques of gold thread embroidery, the methods of embroidering and the types of golden threads in the area of Eastern Slavonia with the emphasis on the technique of gold thread embroidery in Đakovo region. The experimental part of the paper presents the collection of clothing inspired by gold thread embroidery of folklore costumes from the Đakovo region. Designer solutions and patterns of the collection are inspired by tradition and are a good example of slow fashion which proves that designers are interested in old crafts. This means that the revitalization of golden embroidery in the context of slow fashion is increasingly accepted by young designers.*

Keywords: *slow fashion, folk costumes, Đakovo region, gold thread embroidery, tradition, design*

1. Introduction

The most harmful consequences of the fast fashion include increasing pollution of the environment caused by technological processes of garment manufacturing, exploitation of textile workers and rapid changes of fashion trends that encourage consumers to buy more in order to keep up with the trends.

Consumers' favorable response to fast fashion has led to gradual abandonment of conventional production methods and extinction of traditional crafts and skills that fostered cultural heritage through traditional clothing. Another negative side effect of fast fashion is the increase of inadequately disposed textile waste, which poses a grave environmental problem [1]. Slow fashion rises as a response of the environmentally conscious population to the harmful consequences of the fast fashion approach. Slow fashion guidelines rest on sustainability and raising awareness of ethical and ecological values, ignoring fast-paced changes in trends, while striving for the preservation of traditional crafts and production methods. Reflections on the garments' lifecycle through the design and rational use of textile materials will help foster sustainability as a viable approach, essential to the future of fashion industry [1]. Traditional skills employed in the construction of folklore costumes can be a source of inspiration for a contemporary slow fashion collection, thus granting the garments a lasting value in the contemporary context, while simultaneously prolonging the product's lifecycle and fostering the preservation of traditional crafts. In the context of slow fashion, the revival of traditional regional techniques and the preservation of traditional crafts are examples of good practice in raising awareness of sustainable fashion and its positive social and environmental impacts.

2. Traditional clothing and fashion

Clothing has been a part of humanity since the beginning and has always reflected geographical, social, historical and cultural influences. It has always functioned as an indicator of social class and identification with a particular group, reflecting the customs of social community. Folklore costumes as traditional clothing reflected a particular culture and region. As a value passed down to future generations, traditional clothing became a token of ethnic compatibility and a symbol of ethnicity. The developments of the society also affected folklore costumes, which often reflected political, social and economic changes. Traditional wear started to fade into oblivion as the perception and evaluation of clothing began to change with the rise of modern society and the fashion phenomenon. Social and cultural changes and the acceptance of global social influences have pushed traditional clothing to the sidelines, out of the scope of everyday dressing practices [2]. In this context, slow fashion can bridge the gap between tradition and modernity with the emphasis on sustainability.

3. Gold thread embroidery

Ornamental technique of applying “golden” thread to folklore costumes is known as *zlatovez* (gold thread embroidery). A conceptual definition of this embroidery technique first appeared in the early 20th century. Two types of thread were used to perform this technique: a gold-yellow thread was called *zlato* (gold) or *žuto zlato* (yellow gold), and a silver thread known as *bilo zlato* (white gold). These embroidery yarns were traditionally made of silk fibers, copper and other metal threads. Silk threads were considered more valuable, since they proved more durable and better at preserving their shiny appeal, while copper threads tended to tarnish more quickly. Over time, silk yarn was gradually replaced with at the time novelty fool’s gold, which was far less expensive, even though it had less shine and weight in comparison to the authentic gold. This embroidery technique native to Slavonia dates back to the late 19th century, having emerged during the Ottoman occupation of this territory. At that time, gold thread embroidery was performed in combination with *srma* (gold sterling), while ornaments applied to fabrics consisted mainly of oriental motifs. Gold thread and gold sterling embroidery in Đakovo region were applied as decorations mainly to ceremonial dress [3].

3.1. Gold thread embroidery in Đakovo region

The tradition of the gold thread embroidery technique has been particularly well preserved in the Đakovo region due to the use of very distinctive motifs in that region. The clothing style typical to the territories west of the Đakovo city is referred to as Đakovo style, whereas Vinkovci style is typical for the territories to the east. The difference between these styles can be observed in different embroidery techniques. Đakovo style clothing was mainly embroidered over paper, the so called *vezenje naskroz*, which is characterized by minute floral motifs, additionally ornamented with beads. The embroidery and ornaments are two to three centimeters wider in comparison to Đakovo style, and decorative beads are not sewn over entire floral motifs [3]. Beside the two distinctive clothing styles in Đakovo region, there are also three typical embroidery techniques. The first technique is called *vez ubjermanjem*, whereby the gold thread is inserted as weft yarn in weaving. Golden weft threads are inserted through the shed manually with a shuttle. Motifs are predominantly geometrical and the embroidery is seldom adorned with additional ornaments. The second technique is called *vez zlatom naskroz* (full gold embroidery), performed in full flat stitch. This embroidery technique is the simplest, even though tedious and the most expensive, since golden threads are visible both on the face and the back of the fabric. For this technique, embroidered motifs need to be prepared on paper beforehand. The preparation requires the use of two types of paper; one is bright blue, and the other is translucent white. Motifs are first drawn in full lines on the blue paper. The lines on the blue paper are then perforated with the needle, leaving dotted traces on the translucent white paper, which is subsequently placed on the part of the fabric intended for the ornament. The white paper is then sprinkled with blue powder, which leaves traces on the fabric through the perforations to be embroidered with the gold thread. The third technique is called *vez zlatom preko papira* (gold thread embroidery over paper), which is more complex than the previous two, since motifs are embroidered with two threads on a wooden frame called *đerđef* or *đerđe*. The fabric is held in tension over the wooden frame, while motifs previously drawn on cardboard are fastened to the fabric with needle and thread; the motifs are then embroidered onto the fabric. Golden thread is slung over the cardboard, fastened with a plain thread with the right hand and finally tightened over the cardboard edges, so the golden thread remains visible on the technical face, while the plain thread can be observed on the back of the fabric. The space between motifs is embellished with other types of embroidery or ornamental techniques [4]. The Đakovo region is also known for the combinations of several embroidery techniques, such as *kators*; embroidery over paper is combined with *vez naskroz*. Another exceptional type of ornaments are the so-called *prstenkas*, ornaments obtained by winding the thread around a finger, sewing over the wound ring with a chain stitch to create a hoop which is finally adorned with a golden thread and used as a trimming embellishment around floral motifs and to fill blank parts of the fabric. The combination of lace and gold thread embroidery is known as *šlinganje zlatoveza*; the lace is sewn as a trimming on the bottom hems of women’s attire and additionally embroidered, resulting in more lavish versions of the standard gold thread embroidery. The opulence of the adornments was often increased by the use of various additional decorations also specific for the Đakovo region. Most common traditional decorations were made of square and round mirror plates, red, blue and green beads, opaque glass beads known as *mlični biseri* (milky pearls) and metal plates called *pulijas* [3]. The motifs were mainly of herbal, geometrized, anthropomorphic and sacral character. Preferred ornaments and art styles of the period in which these embroidery techniques emerged were also considered status symbols [4].

4. Experimental part

The experimental part of this research was the design of a fashion collection inspired by folklore costumes of Levanjska Varoš, especially *šamijas* (large square scarfs) and motifs in gold thread embroidery as their most distinctive features.

Prior to the preparation of design sketches and the realization of models, we conducted an interview with Ana Muhar, a member of the association “Šokačka grana”, dedicated to the preservation and practice of traditional customs, including the gold thread embroidery. Ana Muhar has dedicatedly cherished tradition and crafts her whole life. Her comprehensive knowledge and experience led to her detailed recount of the history of the folklore costumes in Levanjska Varoš, traditional manufacturing methods and gold thread embroidery ornamental techniques, which provided a relevant source for this topic. Her motifs on *šamijas* in the gold thread embroidery technique were also the source of inspiration for this fashion collection.

4.1. Šamijas of Levanjska Varoš as inspiration for fashion collection

The *šamijas* shown below are the copyright of Ana Muhar, manually embroidered with the gold thread embroidery technique. The author mastered the craft in her work dedicated to the preservation of traditional skills and heritage of the Levanjska Varoš region over many years. *Šamijas* were the first garments to be ornamented with gold thread embroidery in this region. They were most commonly decorated with silver threads, i.e. *bilo zlato* in the *vez naskroz* technique. Typical motifs in Levanjska Varoš include stylized floral patterns such as roses, tulips, poppies, vine, oak leaves, wheat and acorns. The inspiration for the fashion collection is shown in Figure 1 [5].

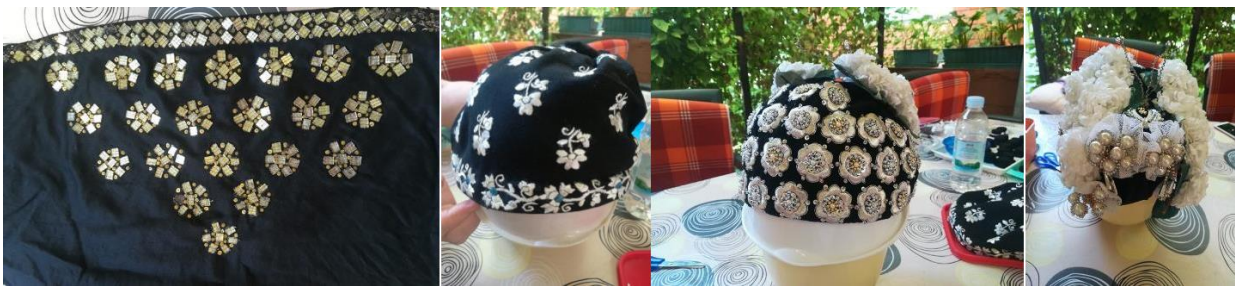

Figure 1: Gold thread embroidered *šamijas* by Ana Muhar

4.2. Revival of gold thread embroidery in contemporary fashion collection

After the gathering of ideas, certain models were selected for the realization of the fashion collection. Since the backbone of the collection was slow fashion and the cultivation of traditional crafts such as the gold thread embroidery, it was essential to design an original motif to be embroidered on the models. The selected motifs were poppy flowers embroidered in full flat stitch in the *zlatom naskroz* technique. The stem of the poppy plant was embroidered in chain stitch, whereas the entire motif was additionally embellished with gold beads, both on and in between the embroidered shapes [5].



Figure 2: Sketch of the embroidery motif



Figure 3: Embroidered jumpsuit

5. Results

The garment selected for the realization is an embroidered jumpsuit from the fashion collection inspired by gold thread embroidery from Levanjska Varoš by an undergraduate student of fashion design. The blouse top and the trousers were constructed according to the instructions from the textbook *Tehnike konstrukcije / modeliranja odjeće (Garment Constructing and Modeling Techniques)* by Ujević, Rogale and Hrastinski. The jumpsuit top was designed with the fold-over front. Motifs in the gold thread embroidery technique were applied on the back of the neckline and along the entire length of the front folds in 8-centimeter width. The slacks have 6-centimeter gathers on the darts and are slightly flared below the knee line [5].

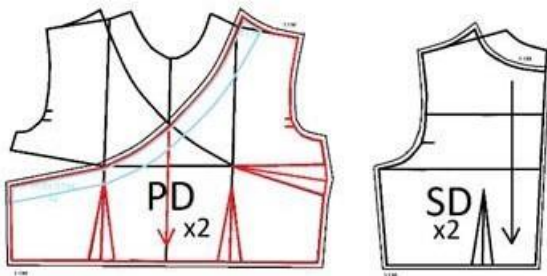

Figure 4: Cutting parts of the jumpsuit blouse top [6]

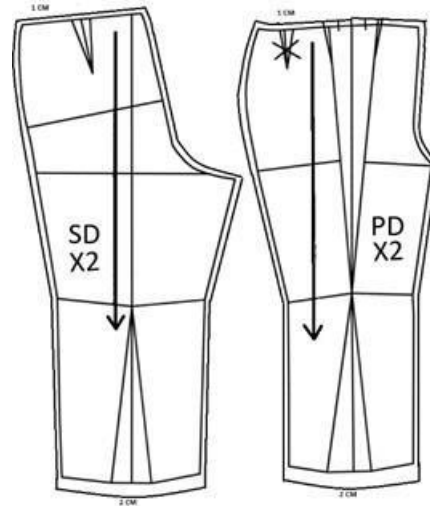

Figure 5: Cutting parts of the jumpsuit trousers [6]



Figure 6: Realized jumpsuit from the fashion collection



Figure 7: Embroidered motifs on the jumpsuit

6. Conclusion

The negative consequences of fast fashion approach have given rise to the new guidelines in the form of the slow fashion approach, which, among other things, advocates the revival of traditional crafts. The traditional approach and its region-specific manufacturing techniques increase the value of garments and expand their lifecycle, since they are not subjected to fast changes in fashion trends. Gold thread embroidery can be applied to any garment; in the fusion of tradition and modernity, this technique goes beyond traditional wear and becomes an adornment in contemporary fashion, providing the garments with a lasting value, ranging from prêt-à-porter collections to haute couture as shown in figures 6 and 7.

In the context of slow fashion, the gold thread embroidery technique offers countless possible applications. This paper demonstrates only one example to prove this. The future generations of young designers will increasingly turn to traditional motifs as an unlimited source of inspiration, translating them to contemporary collections for new generations of responsible consumers, who will opt for a modern and contemporary style, ending their slavery to ever-changing fashion trends.

References

- [1] Ninimäki, K.: Sustainable fashion: New approaches, Aalto University publication series, Aalto ARTS Books, ISBN 978-952-5572-5, Helsinki, Finland, (2003)
- [2] Maglica, N.: Baranja se šareni: Predajno ruho baranjskih Hrvata, Etnografski muzej, ISBN 953-6273-25-X, Zagreb, (2003)
- [3] Juzbašić, J.: Zlatovez na području istočne Hrvatske: Prigodom „Šokačkog sijela 2008“, Zavičajni muzej Stjepan Gruber, ISBN 978-953-7547-01-1, Županja, (2008)
- [4] Juzbašić, J.: Slavonski zlatovez, Zavičajni muzej Stjepa Gruber, ISBN 978-953-7547-38-7, Županja, (2018)
- [5] Duić, D.: Zlatovez Đakovačke narodne nošnje kao inspiracija za projektiranja kolekcije odjeće, Sveučilište u Zagrebu Tekstilno-tehnološki fakultet, Zagreb, (2019)
- [6] Ujević, D.; Rogale, D.; Hrastinski, M.: Tehnike konstrukcije i modeliranja odjeće, Tekstilno-tehnološki fakultet, ISBN 978-953-7105-36-5, Zagreb, (2010)

Authors:

Assist. Prof. Irena ŠABARIĆ, PhD.

University of Zagreb, Faculty of Textile Technology, Department of Textile Design and Management

Prilaz baruna Filipovića 28a, HR-10000 Zagreb, Croatia

Phone: +(385) (1) 3712 554

Fax: +(385) (1) 3712 599

E-mail: irena.sabacic@ttf.unizg.hr

Franka KARIN, mag. ing. techn. text. (corresponding author)

University of Zagreb, Faculty of Textile Technology, Department of Textile Design and Management

Prilaz baruna Filipovića 28a, HR-10000 Zagreb, Croatia

Phone: +(385) (1) 3712 554

Fax: +(385) (1) 3712 599

E-mail: franka.karin@ttf.unizg.hr

Doriana DUIĆ, ing. techn. text.

University of Zagreb, Faculty of Textile Technology

Prilaz baruna Filipovića 28a, HR-10000 Zagreb, Croatia

THE INFLUENCE OF CHINESE FOLK COSTUME ON THE DESIGN OF WOMEN'S BUSINESS CLOTHING

Ivan MIHALJEVIĆ; Blaženka BRLOBAŠIĆ ŠAJATOVIĆ & Maja MAHNIĆ NAGLIĆ

Abstract: *The paper presents a study of Chinese folk costume with an emphasis on the dresses of the Chinese woman Qipao or Cheongsan. A historical overview of Chinese women's folk costumes is given with an emphasis on its influence of traditional clothing on contemporary design and women's fashion. According to the original design, block patterns of collection clothing models were constructed and modeled. Special emphasis is given to selected materials, clothing and high stylization. The ultimate goal of the work is to make a modern garment based on the study of traditional Chinese folk costumes.*

Keywords: *China, Folk costume, Construction, Business clothing*

1. Introduction

China's garment industry is now at a time of major change and development in addition to political liberalisation, economic development and a reduction in trade barriers, Chinese apparel faces strong international competition, so it must constantly strive for innovation and upskilling in order to achieve a real growth. Chinese folk costumes are described through a historical overview and emphasize their own influence on contemporary fashion design. The implementation of elements of Chinese folk wear in the design of women's clothing confirms the grace and elegance of Chinese costume that is still present in the fashion world today [1].

1.1 Chinese national costumes through history

Qipao is a traditional Chinese, national dress. The word qipao has become a more formal term for female cheongsam, type of feminine body-hugging dress with distinctive Chinese features of Manchu origin. Clothes are divided into three groups - winter, spring and autumn and summer. It varies depending on the presence or absence of the lining and cotton substrate. The clothes stand out with their grace and elegance. In short, beauty and sophistication - it is all traditional Chinese folk costumes.

Traditional Chinese costume called "Hanfu" still not losing popularity, Figure 1. Often used as a historical dress or traditional costume for various celebrations. In everyday style, elements of traditional costumes are now used [1].



Figure 1: Traditional Chinese costume [2]

China's national apparel emerges with Chinese civilisation boom. At the same time, with the arrival of each new dynasty, on cloths details have changed. Its sumptuous and rich colour remained unchanged. The Han and Jin dynasty's national costumes looked rather restrained. Then came the basis for the traditional Hanfu costume, which was later supplemented by a small number of decorative elements. At the time, the ancient costume of Hanfu was considered a traditional dress by the Chinese emperor and his family. The next ruling Tang dynasty has made traditional costumes more lavish. Then welcome dresses are decorated with patterns and jewels.

Costumes during the Ming and Sleep dynasties began to look more elegant. Elegant dresses and skirts for girls and sophisticated men's suits emphasized the peculiarities of high Chinese culture. Intricate patterns and fantasy motifs were added to traditional Chinese costumes during the Qin Dynasty. The 1930's were coincided with the end of the Chinese monarchy. This, of course, was reflected in the characteristics of the traditional Chinese dress, which became a little more modest and restrained. However, the national clothes of the inhabitants of this country always stand out with their brilliance and originality. Like all national costumes, traditional Chinese clothing has a number of features that reflect the characteristics of the Chinese worldview and their traditions [1].

2. Construction of qipao

A qipao can be made from many types of textiles, almost any material that can hold a reasonable shape and does not have too much stretch in it (even a stretchy material, with enough weight, could be used for a qipao, although some allowances need to be made when structuring the zipper and buttons. For everyday wear, cotton or linen are materials used for summer, while wool or cashmere are for winter. Silk, velvet and lace tend to be used for more dressy and formal occasions, often adorned with embroidery, beads or sequins. Traditionally qipaos are fully lined. Many modern qipaos, especially cotton or linen ones for the summer, no longer have a lining for a more casual and lighter look, Figure 2.

There are two broad qipao fits. The most common and classic fit being the Shanghai-style or Haipai fit, which has a similar silhouette to a pencil-dress and can be extremely figure-hugging. The less common fit is the Beijing-style or Jingpai fit, which is more or less A-line. There are of course variations of each and combinations of both [3,4].

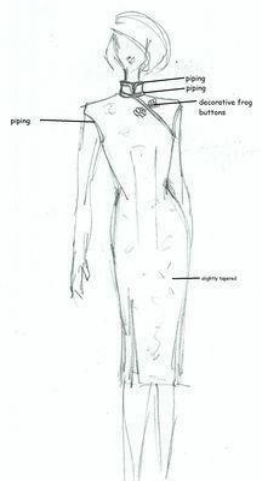

Figure 2: Parts of qipao [5]

2.1 Collar of qipao

The mandarin collar is one of the most quintessential parts of a qipao. The collar is usually made from a single piece of material that wraps around the neck, with the two ends meeting at the center front of the neck. The two corners of the ends at the base of the chin are rounded and slightly open, while at the base of the collarbone they are tightly closed. The collar can, and historically has been, made in a range of heights. At one extreme, in the early 1910s, collars were so high that they reached the bottom of the ears, whereas in the early 40s during the war, collars were very low, perhaps just a few centimeters (an inch) high, Figure 3.

Going all the way back to the Manchu pao of the Qing dynasty (ancestors of the qipao, and where it derives its name), those were in fact collarless. The collar height is most often 4-5cm (1.5-2 inches), but there are higher from about 6-7cm (2.5-3 inches), high enough to cover almost the entire neck but not quite as dramatic as under the ear-lobe. This was a very popular height in the 1930s.

2.2 Pankou

Pankous are traditional Chinese knotted buttons, and were used to fasten the qipao together, running from the base of the mandarin collar down the front of the qipao (the name of the diagonal chest opening), all the way along the right side of the body, Figure 3.

Pankous range from extremely simple straight pankous to very elaborate floral designs. The straight pankou is the most common, and usually runs in a series of three on the collar and chest area: one at the base of the mandarin collar, and two along the chest portion of the front. When a floral pankou is used, it would typically come in a set of two: a large main piece on the chest, and a matching small piece at the base of the mandarin collar. In some of the more formal 30s-50s era vintage qipaos Pankous went in and out of vogue over the years.

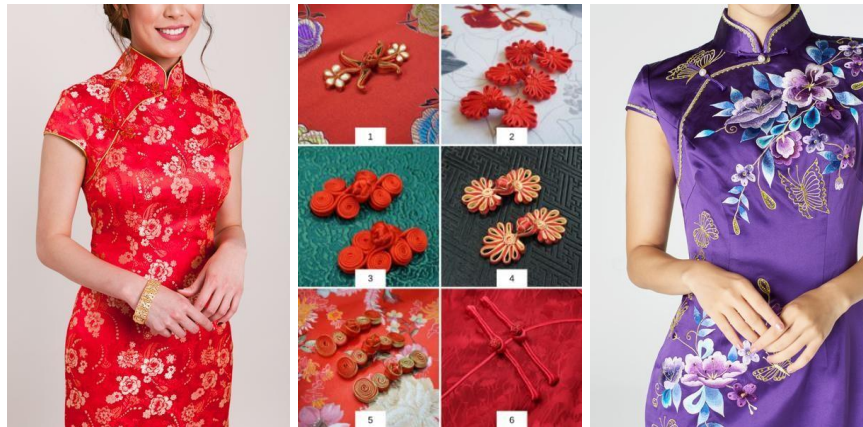

Figure 3: Colar, pankou, lining and sleeve of qipao [6]

After the 1940s when “revised qipaos” with zippers became popular, many qipaos were made without pankous and used only press studs. The front part of the qipao is called the large front, or simply front. It is essentially the frontal closure area of the qipao, and like the button down area of a shirt, is traditionally how a qipao is put on and taken off. Usually the front includes a diagonally shaped chest area, enclosed by a series of pankous.

Most of the fronts used today are right-opened large round fronts, running from the base of the of the centre of the collar to just underneath the right armpit in a downward facing arc. The most common double sided front is the round ba-front, a dual-sided version of the large round front. These tend to be decorative on the left side and open on the right only. Unlike collars and pankous, there was less of a fashion aspect to fronts. The right-opened large round front has consistently been the most popular choice over time, dating from its original use on the Manchu robes [3,7].

2.3 Lining of qipao

Traditionally, all visible edges of a qipao are finished with at least one of four special edging techniques: gun, xiang, qian or dang. The original Manchu pao used combinations of these techniques to create elaborate edges with multiple types of materials. This simplified over time, and today a single gun-edge is most common. It is the single-colored narrow edging seen on many qipaos, and made from stitching a narrow piece of material which is rolled (the literal meaning of “gun”), or wrapped around the edge of the qipao [3].

2.4 Qipao sleeve

The most typical sleeve lengths seen on a qipao today are either sleeveless or fitted cap sleeves, made for the summer months. But over the years they have come in a range of shapes and lengths. Qipaos evolved from Manchu robes, and the very original sleeves were “hoof-cuffed” (ie. very tight around the wrists) long sleeves. Over the Qing dynasty, they were influenced by Han clothing, and the sleeves became extremely wide long sleeves, Figure 3.

In the 1920s, qipaos gained quite a distinctive flapper flair, and bell shapes in a variety of lengths became popular, especially those with a scalloped or embellished edge. In the 1930s and 40s, sleeves became more minimal and straight, and in the summer times they became very short. It’s important to know that from the Qing dynasty through to the 30s and 40s, sleeves were all grown-on, cut in one piece with the body of the qipao, with no shoulder seam. This is quite different from the set-in sleeves used on almost all clothing today, where the sleeves are attached separately to the shoulder. Grown-on sleeves were also very popular in the West in the 1950s, on blouses to match the full circle skirts, and they generally have some loose fabric around the shoulders to allow for movement.

Qipaos have historically been popular in a range of lengths. As mentioned above, the 1920s qipaos were influenced by flappers, and so dress lengths ranged from below the knee to mid-calf, just like their flapper counterparts. As qipaos of this era were not yet very body-hugging, and some used techniques such as pleats in the skirt, side slits were not yet prevalent. Towards the end of the 20s, skirts became more narrow, and so short side slits which start at or below the knees became popular by way of practicality. By the mid 1930s, the golden era of qipao, qipaos became floor-length, and side slits crept up to the thighs, creating a very sensual silhouette. From the 1940s and beyond, qipaos again decreased in length. From the 1940s-60s, below the knee and mid-calf were common lengths. As qipaos tended to be quite fitted in this era, slits tended to start above the knee for ease of movement [3,7].

3. Elements of Chinese costume in contemporary design and fashion

Traditional Chinese costume inspires many modern designers. Her elements appear in dresses for everyday life and in festive paintings. The rich and at the same time quite restrained traditional Chinese clothing inspires with its lightness and style, both ordinary fashion lovers and famous designers.

Fashion designers like Masha Ma, Zang Na, Huishan Zang, Dido Liu, Jiking Jin, Fiona Lau, Kain Piken, Uma Wang, Vivienne Hu, Kiran Huangi and many others manage to incorporate elements of traditional Chinese folk costume with elements of modern design. They also contribute by choosing clothes for business, private and formal occasions, Figure 4.

More and more global brands like to use Chinese traditional elements in their design. On October 1, 2006, Chinese designer Xie Feng showed off her “Doors” collection at Paris Fashion Week. It was the first time that a brand of a Chinese designer was officially shown at the opening of that fashion week.

Chinese designers are increasingly appearing in the global fashion arena in recent years, expressing their own design philosophy in an effort to set fashion trends. More than 20 Chinese designers presented their fall / winter collections for 2019 at the ongoing New York Fashion Week, which is almost twice as many as two years earlier. For designers like Masha Ma, Zang Na I Dido Lu is a phenomenon “something that should have happened,” as China has gone through lightning-fast economic and social development over the past few decades. This designer, back in her 20s, already had a brand presentation with her name at fashion weeks in London and New York. Masha Ma is among Chinese designers who boldly express their ideas of female power. Her latest pieces contain romantic colors and cute styles. Through such a look she wanted to show that cuteness can also be powerful for women. These designers never forget to embrace Chinese culture on its way to the global stage. Last year, designer Vivienne Hu unveiled a collection inspired by murals in Dunhang Caves, a 1,600-year-old UNESCO World Heritage site in northwest China [8,9]. The pieces were praised immediately after their release and have remained to this day the best accepted pieces of clothing she designed, Figure 4.



Figure 4: Business attire with elements of tradition [10]

4. Collection inspired by elements of Chinese tradition

Six items of clothing are processed through the mini collection: a blouse, trousers, two dresses, a jacket and a coat. The jacket has the same inspiration as the items listed so far. The length of the cut boils the height of the hips by about 15 centimetres. It features a standing collar that has a larger neckline width. Also, it has long sleeves whose shoulder part is modelled with an additional seam to obtain a structure in the shoulders. The

jacket has an internal double fastening, Figure 5. The robe has long sleeves with added cuffs. On the right side there is a zipper that goes from the top of the collar to the end of the length of the coat. The cloak has a standing collar, Figure 6.



Figure 5: Sketch of the jacket

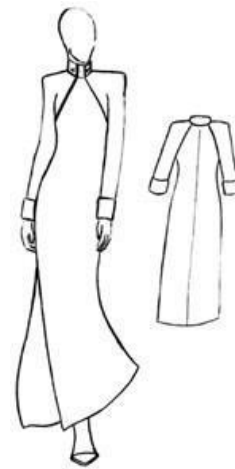

Figure 6: Sketch of the cloak

The pants are developed towards the side cut on the qipao dress. Cut on the pants is modeled on the principle of slits on women's dresses. The slit starts from the front of the thigh and descends 5 cm below the height of the ankle. Zipper is located on the front side and it is moved obliquely from the center of the groin to the right side of the hips. The pants are high waist. Blouse was developed on the same example of a qipao dress. It is free of collapses in the trunk area and has an asymmetrical cut. Great comfort is achieved by folding the cut. The blouse has a low standing collar, Figure 7.

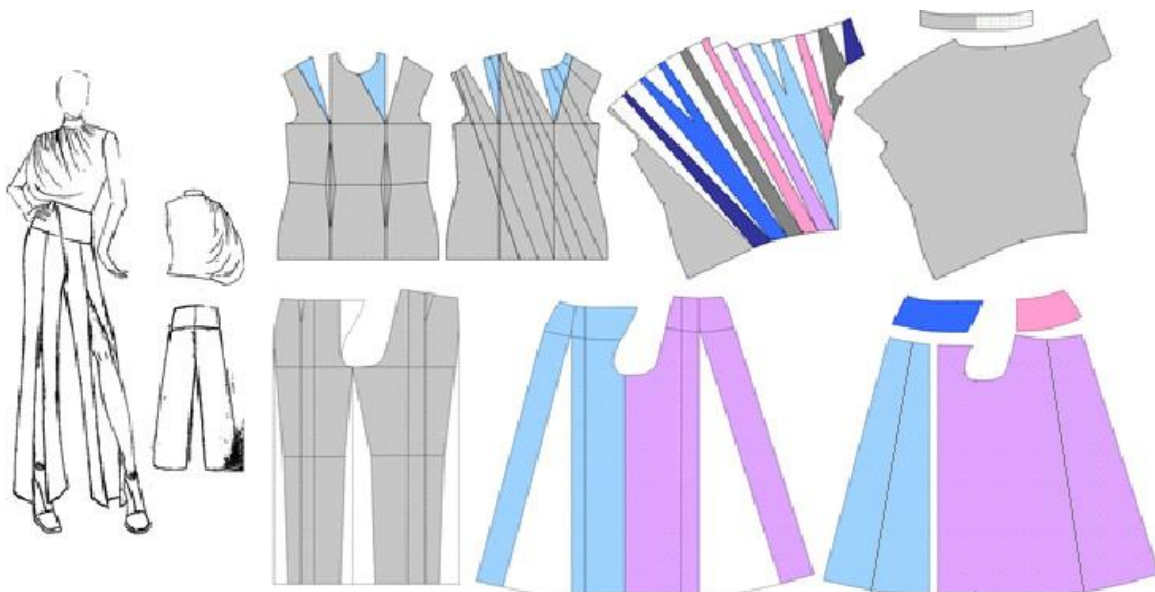

Figure 7: Sketch and modeling of blouse and pants

The dress model 1 was created on the idea of modernizing the traditional qipao dress. The dress has short sleeves, a standing collar and has a buckle along the length of the body line, Figure 10.

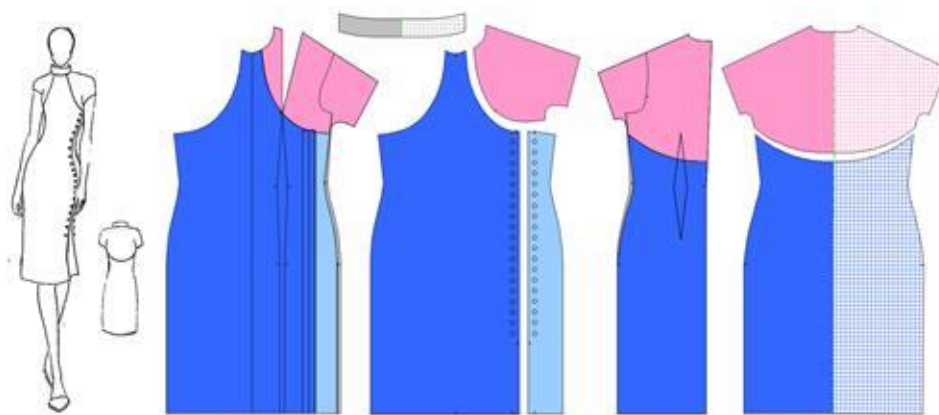

Figure 8: Sketch and modeling of a dress model 1

The second variant of the described dress model 2 has raglan sleeves, a standing collar and a buckle in the front middle in the area of the collarbone, Figure 11.

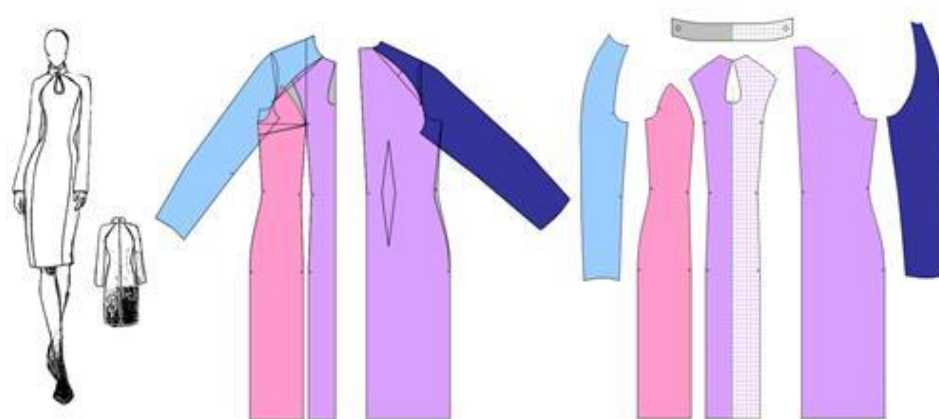

Figure 9: Sketch and modelling of a dress model 2

5. Conclusion

This paper deals with women's traditional Chinese qipao dress. It is analyzed through historical periods, ethnology, culture, clothing, society and space. Costume is primarily collective and determined in community while fashion is individual. The original use and design principles of the qipao dress are used as a starting point, and we get a completely new garment that contains the values of the original elements: function, protection, the possibility of freedom of movement. Its historical, social and aesthetic characteristics are used in a way to emphasize its aesthetic and cultural value today through a mini collection.

References

- [1] Paić, Ž.; Purgar, K.: *Teorija i kultura mode*, DURIEUX, ISBN 978-953-7105-71-6, Zagreb, (2017)
- [2] Available from <https://www.newhanfu.com/the-5-most-classic-traditional-chinese-dress-clothing.html>, Accessed: 2020-08-10
- [3] Chew, M.: Contemporary Re-emergence of the Qipao: Political Nationalism, Cultural Production and Popular Consumption of a Traditional Chinese Dress, *The China Quarterly*, **189** (2007), pp.144 - 161
- [4] Finnane, A.: *Changing clothes in China : fashion, history, nation*, New York : Columbia University Press, ISBN: 9780231143509, New York, (2008)
- [5] Available from <https://blithestitches.wordpress.com/tutorials-tips-and-tricks/tutorial-anatomy-of-a-cheongsam/>, Accessed: 2020-08-10
- [6] Available from <https://eastmeetsdress.com/blogs/blog/5-chinese-elements-to-add-to-make-your-dress-a-modern-qipao>, Accessed: 2020-08-09
- [7] Lin, C. L.; Khuen, C. M.: *In the mood for cheongsam*, NSM, ISBN 978-981-4260-92-3, Singapore, 2012

- [8] Available from <http://www.kina-danas.com/kineski-dizajneri-sve-prisutniju-u-globalnoj-modnoj-areni/>,
Accessed: 2020-05-26
- [9] Tsui, C.: *China fashion : Conversations with designers*, Oxford Berg Publishers,
ISBN:9781847888600, New York, (2010)
- [10] Available from https://www.upi.com/News_Photos/Entertainment/Beijing-Fashion-Week/7592/ph21/ ,
Accessed: 2020-08-15

Authors:

Ivan MIHALJEVIĆ (corresponding author)

Assist. Prof. Blaženka BRLOBASIĆ ŠAJATOVIĆ, PhD., Maja MAHNIĆ NAGLIĆ, mag. Ing techn. text.

University of Zagreb, Faculty of Textile Technology

Prilaz baruna Filipovića 28 a, ZIP-10 000, Zagreb

Phone: +(385) (1) 3712 561

E-mail: vmihaljevi1@gmail.com,

E-mail: blazenka.brlobasic@tff.hr,

E-mail: maja.mahnic@tff.hr

CONSTRUCTION OF A MODERN WOMEN'S COSTUME INSPIRED BY MEN'S FASHION

Sara ŠUMANOVIĆ & Renata HRŽENJAK

Abstract: *Subject of the following paper is the construction of a modern women's costume inspired by men's fashion in the 90's of the 20th century. The appearance and evolution of women's costume through history, from the end of the 19th century when the ideas about the need for a reform of women's fashion were firstly born, until modern time we live in were explored. Particular emphasis was placed on sociological access to fashion aimed at better understanding of the importance of cultural and political changes affecting development of women's costume. Through the aspect of men's fashion and men's suit collections, the 90s of the 20th century were then analyzed in order to understand the elements that would serve as inspiration for collection. In the experimental part development of collection of a modern women's costume was presented. The construction of pattern as well as one of the suggested models are shown.*

Keywords: *women's costume, history, changes in society, identity, men's fashion*

1. Introduction

Throughout history, cultural and political changes have greatly influenced fashion in general and thus the development of women's costume. But it is often fashion that has influenced the shaping of social consciousness, especially when it comes to women's dress. We can therefore consider fashion as a means of communication but also of differentiation. With the increasing awareness of the increasingly active role of women in society and the emergence of the need for more functional clothing, in the late 1990s, women's costume emerged as a new garment developed from men's suit. The ideas of abolishing gender differentiation through clothing were finally brought to life in the first decades of the 20th century, and the appearance of modernism was slowly moving away from ideas about society, including fashion.

But what role does the idea of identity and the cultural changes that take place in the 20th century really play in the creation and development of women's costume? The answer to this question will be attempted through further theoretical elaboration of the topic. The emphasis will be on the development of women's costume, its contemporary form, and the influence of men's on women's fashion, but also on the historical and cultural changes that have greatly influenced the appearance and design of women's costume [1].

1.1 The appearance and development of women's costume

Fashion, and especially women's, has been subject to various changes throughout history. Probably the most significant change was when the corset and lush petticoats cease to be part of everyday life [2]. As awareness of the importance of women's emancipation increases, so does the desire to free the body of solid forms such as corsets. Also, when studying the appearance of women's costume, it is worth pointing out the moment when there is a change in the division of clothing forms into "male" and "female". Katarina Nina Simončič in her book *The culture of dress in Zagreb at the turn of the 19th to the 20th century* states that the basic division of clothing, trousers for the male population and dresses and skirts for female, which dates from the 14th century, remained until 90s of the 20th century [3]. In 1851, Amelia Bloomer, along with Elizabeth Stanton and Elizabeth Miller, popularized the bloomer costume, which was considered a healthier and more comfortable option compared to the then popular hourglass form. The bloomer costume was one of the foundations for the elimination of gender differentiation through clothing, consisting precisely of wide-trousers, tight at the ankles, over which the skirt was worn. Trousers were strictly forbidden for women as a basic garment for men. Therefore, Bloomer's girls were considered inappropriate, but they became a symbol of women's struggle for equality and opposition to the social roles and dress codes imposed on them [4]. A little later, in the 1990s, as they became aware of the more active social role of women in society, they became more prominent in public life, but began to become vocationally trained. There is the emergence of a women's costume, or suit, a garment form previously reserved exclusively for men. In 1906, the French designer, Paul Poiret, liberates a woman's body and revives women's trousers. Through his work he has contributed to creating awareness of the great need for the emergence of new styles in women's fashion, and has open up the way for reforms in the area, as well as the foundations for the emergence and development of women's costume [5]. However, French designer Coco Chanel is considered to be the most significant person when it comes to women's

fashion of the 20th century. Inspired by men's fashion, in 1914, she created women's sweaters of a straight, relaxed cut, modeled on those worn by fishermen and polo players. The materials she used, as well as clean, simple lines, she drew from men's fashion. The clothes she created were practical, comfortable but also elegant and appropriate for a rather unpredictable aesthetic during the First World War. By 1917, the name Chanel was well-known on both sides of the Atlantic, and jersey became a common material for making day dresses and other tailored garments. In the 1920s, Coco Chanel designed a women's costume consisting of a loose-fitting jacket without a collar, resembling a cardigan sweater, and a straight cut skirt. The women's costume is now not just an ordinary garment, it is also a reflection of gender and gender differentiation, that is, communication. Creating a Chanel-look using a women's costume made of a jacket and a straight skirt, she changes traditional hourglass silhouette (Figure 1a) [6]. Although Chanel designed a women's costume modeled on men's patterns, the bottom of the costume was a skirt. The first women's costumes, with trousers underneath, appeared in the 1930s. The trousers also, like the skirt, drew attention to the body. Women enthusiastically embraced new garments, but many did not accept them because they considered such an takeover of "male" clothing elements inappropriate. In 1930, Marlene Dietrich in the movie *Morocco*, dressed in a male, black tuxedo costume designer Travis Banton, and provoked numerous reactions. Until then, trousers were a functional and workwear-only clothing item.

However, the first real women's costume with trousers as the lower part appeared in 1932, and its creator is considered the French fashion designer Marcel Rochas. Rochas introduces gray wool trousers and a matching jacket with padded shoulders, and created a new version of the women's costume. Although Coco Chanel, Marcel Rochas, and Elsa Schiaparelli both bring their own versions of such costumes in their collections, they were initially worn only by the "bravest" women. That didn't change until the 60's, when in the post-war years women started to have a working relationship, so costumes with pants became acceptable clothing for the workplace and, over time, for more festive occasions. Female masculinity became a trend that contrasted with women's fashion, which advocated a delicate and slim-fit silhouette and body-strapped materials. However, Coco Chanel emphasized that her costume was boyishly, not manfully, and that she wanted to harmonize her femininity [7]. During World War II, appearance and fashion lost their importance in the construction of individual gender and gender identities, and fashion styles remained almost unchanged. At the end of the war, the Paris fashion scene is making efforts to regain the status of fashion capital. In 1947, with his popular name, the New Look collection, Christian Dior set a new trend in women's fashion, including the design of women's costumes (Figure 1b). He sets the image of the radical femininity he achieved with tight jackets with padded hips, a narrow waist, A-line skirts and pleats. The New look represented traditional femininity, not the appearance of an emancipated woman. Despite its initial outcry, Dior's Bar Costume became one of the most recognizable clothing forms of the late 1940s and early 1950s [8]. The costume consisted of a single-breasted jacket and a rounded lower edge of the front middle, which perfectly followed the body line, emphasizing the bust line and the narrow waist. Dior takes another step away from the aesthetic of the war and stops emphasizing women's shoulders, with the A-cut skirt emphasizing her hips. It triggers a new revolution in women's fashion, achieved great success and becomes a respected designer. In the 1950s, Dior gradually made costumes with skirts of ever shorter lengths, and jackets slowly began to lose their waistline, getting a straight cut. From the initial hourglass silhouette, as a complete opposite, Dior later developed a completely flat I-silhouette, from which the H-silhouette is formed.



Figure 1: a. Chanel costume [9], b. Dior New look [10], c. YSL Le smoking [11]

Shortly thereafter, variations of the costume in the Y-silhouette appear, with an accentuated upper and a subtle, flat bottom. The women's costume still traditionally consisted solely of jackets and skirts, which became ever shorter during the 1950s. With the appearance of mini skirts, more and more different variations of costumes occur. With women's increasingly persistent struggle for their rights, there are more rapid changes in dress. However, society has not made much progress in terms of awareness of women's rights and women's position in society. This also tells us that women's trousers have not yet been fully accepted, and that women's costume is still acceptable exclusively in combination with a skirt. Any departure from such rules would often be punishable. In 1966, Yves Saint Laurent, in his fall-winter collection, presents *Le smoking*, one of the cult YSL pieces that has retained that status to this day (Figure 1c). Saint Laurent does not create a copy of the classic men's tuxedo, but uses similar principles of construction and modeling and adapts it to the woman's body. *Le smoking* consisted of an evening jacket made of wool or black satin, black trousers with a satin side strip, white shirts, bow tie and a wide satin cummerbund belt. The YSL tuxedo was a bold alternative to a elegant little black dress [12]. A year after the tuxedo, in 1967, Saint Laurent's traditional men's suit adapts to women and displays it in their spring-summer collection. It was an unusual design for a woman's costume, which, until then, has traditionally been worn with a skirt [13]. Despite the new wave of feminism in the 60's, women's trousers were still a controversial garment. This is evidenced by the very fact that Nan Kempner, then a member of high society, was barred from entering an exclusive New York restaurant for not respecting the dress code. Specifically, Kempner was dressed in a YSL costume with trousers, in her last couture fashion. In protest, Kempner "complied" with the dress code by removing her trousers and remaining only in a long jacket that then imitated a short dress. In this way, she completely stripped her legs, but this was still more acceptable than a woman in trousers, which was considered a "man's" garment [6].

Nevertheless, all of the above has laid a good foundation for new reforms in women's fashion, and this is especially true of the women's costume that is the subject of this paper. In the 1970s, most European and American women had a permanent job, which is why there is a growing need to wear costume as a business outfit. Instead of serious, tight suits, the Chanel look style is becoming increasingly popular; tweed costumes combined with silk blouses. In 1977, John Molloy publishes a sort of business clothing selection guide, the book "Suits for success." From the very beginning of the women's struggle for independence, clothing has been one of the means of communication and differentiation [14]. There are more and more successful businesswomen in the 80s, and designers are creating the image of an independent, superior woman. However, in the 80's there is a shift away from the androgynous style, and kitsch elements appear. Extremely large, padded jacket shoulders, large accentuated buttons, different belts, a multitude of jewelry, etc. The costume is gaining more and more elements of women's fashion and is being balanced with the "masculine" features on the women's costume. In the 1990s, there was no longer any challenge to women's options compared to men's. During this period, Coco Chanel and Saint Laurent, who were one of the initiators of the whole revolution of women's clothing, returned to the aesthetic again. Again the elements of tailoring and modeling men's clothing are increasingly influencing women's fashion. The kitsch of the 80s has been replaced by minimalism, and we meet both variants of women's costume, either with skirt or trousers. When women finally fought for their social and political rights, but also for their freedom of choice, the costume was no longer solely a symbol of rebellion and gender identity, but entered into everyday life. At the beginning of the 21st century, a completely different and more liberal atmosphere prevailed in society, which was also reflected in women's fashion. Emphasis is placed on identity, expression of one's individuality, and fashion becomes accessible to all. All of this was reflected in the women's costume today, which is free from all rules. It appears in various variations, from the classic traditional ones, through the more relaxed modern versions, to the conceptual ones, which makes it difficult to define the elements of women's costume in the postmodern era.

1.2 Men's fashion in the 1990s

During the recessionary years of the early decades, there was a reaction to the extreme consumption that marked the 1980s. For almost a century, it has been common for fashion styles and catwalk trends to flow into mainstream fashion. However, in recent decades, the reverse process has been occurring. In the 1970s and 1980s, street style elements began to appear in high fashion, but in the 1980s, styles of different subcultures were increasingly taken over, leading to the development of a variety of styles. In the early 90's, a combination of punk and hippie style, created grunge that was particularly popular in the United States. Back then, a number of designers referred to the styles of the late 60s and 70s, returning in the mid-decade to many elements of the 1980s aesthetics, such as accentuated, padded shoulders. Various minimalist interpretations of military and sportswear with quilts, hoods, zippers or Velcro tapes also appear. The fashion of the 90s was the product of a comprehensive change of the West. It was a decade of cultural and sociological change, the breaking of taboos and rebellion. The body begins to take on a whole new meaning, and the understanding of its appearance changes. Body ornamentation with tattoos and piercings is becoming accepted [15]. All of this favored a return to an anti-conformist, more "straight" approach to fashion and dress, which popularized the casual chic look, which included T-shirts, jeans, sweatshirts, etc. Corporate offices are also becoming less

formal, so business casual style is emerging. Thus, the suit studied in this paper gets an ever wider, more relaxed cut. Relaxation and minimalism are becoming new fashion trends, and more and more are insisting on the rejection of tight and rigid formal wear. The appearance of more informal workwear was actually the result of the 90's, which was full of baggy, gray suits, and high-quality, but somewhat dull cuts. The aesthetics of the time were often not entirely focused on visual, aesthetic experience, but more on practicality and rapid innovation. The distinctive look from the '90s collections featured minimalist, exquisitely tailored clothing, often in neutral tones, mostly in gray or, in contrast, in bright colors. The emphasis was on luxurious, mostly natural materials, such as leather, cashmere, fur, feathers, hand-felted wool, often woven into tweed, etc. [16]. In 1990, Jean Paul Gaultier and Giorgio Armani presented their collections that influenced the further development of men's fashion, and especially men's clothing in the 1990s [17]. Jean Paul Gaultier's Spring-Summer 1990 collection, featuring elements of gender-neutral and sporty fashion, laid the groundwork for the integration of luxury fashion and athletic gear. Giorgio Armani's Autumn Collection in 1990 presents men's suits that made it easier to move and comfortable to wear, moving away from the stiff and over-lined clothing that was hidden by the body (Figure 2a). He gradually changes the layout of the buttons on the jackets and their proportions, and believes that he has radically transformed his clothes. This gave the jackets comfort, lightness, and thus improved the construction of garments. Although the formal attire was mostly in black, shades of gray or some more neutral color, Tom Ford for Gucci, in the fall 1995 collection, makes a departure from the classic men's suit (Figure 2b). It retains the simple, minimalist design that has been prevalent throughout the decade, but comes away with colors, borrowing them from street-style dress.



Figure 2: a. Giorgio Armani 1990. [18], b. Gucci 1995. [19]

Today, many designers create their own collections inspired by the spirit and aesthetics of the last decade of the last century, and quite often new brand names inspired by the street fashion of the 90s appeared, which greatly influenced the changes in the form and appearance of the men's suit of the period.

2. Experimental

In the experimental part of this paper, models of a mini collection of contemporary women's costumes inspired by men's fashion are proposed. A basic costume design for women's costume [20] was also made, consisting of a jacket and trousers, and one of the proposed models was modeled.

2.1 Design of a mini collection and shaping a model inspired by men's fashion

The inspiration for the creation of a mini collection of women's costumes was men's fashion in the 1990s. In the aforementioned decade, more informal work clothes of minimalist lines began to appear, partly as an influence of street fashion. Men's fashion collections abounded with wide, baggy cuts with slightly longer outer garments and wide trousers legs. It was these elements that inspired the sketches. Figure 3 shows three models of women's costumes (by Sara Šumanović). The basic pattern of the women's jacket, the corresponding two-piece sleeve and the women's trousers were used to make the basic pattern of the women's costume. The selected women's costume, Figure 3a and 3d, consists of a jacket and trousers. The jacket has a wide, oversized pattern, as well as a matching sleeve that is also slightly longer than the base sleeve pattern. The single breasted with one button has been moved to the side, with a sewn pocket on the left front. The trousers are straight cut and waist high and are slightly longer than the standard length of the base pattern, with the zipper hidden in the side seam. Figure 4 shows the modeling procedure for the front of a woman's jacket. To extend the front of the base pattern, it was measured 15 cm from the pattern length line downwards.

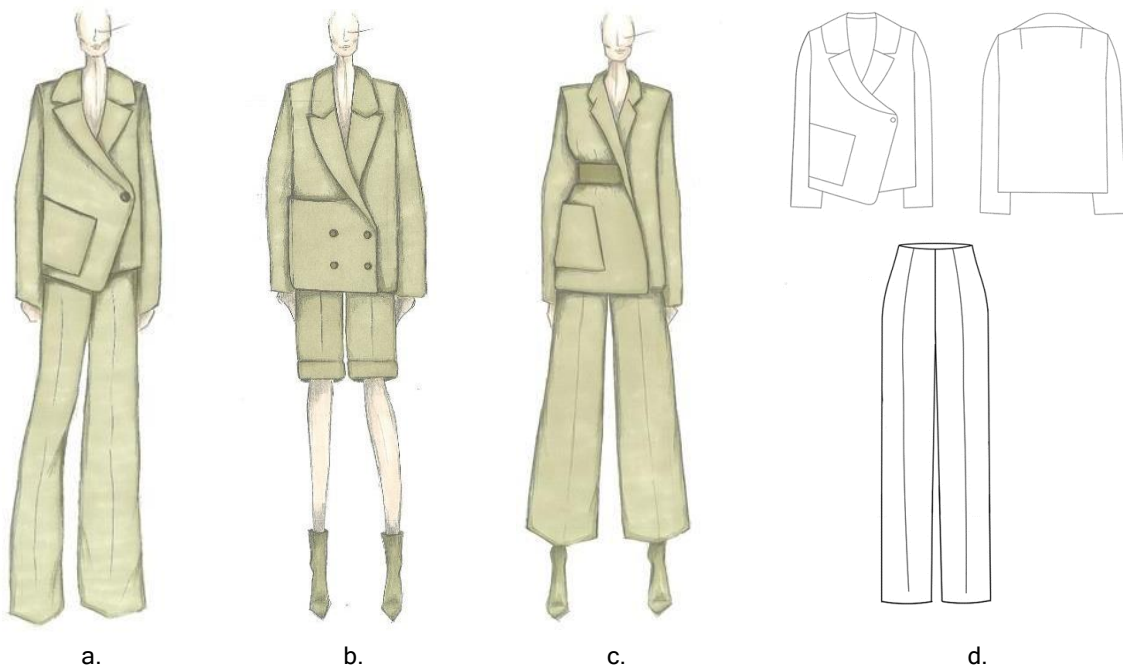

Figure 3: a., b. and c. Mini collection by Sara Šumanović, d. Technical drawing of the selected model a. [1]

The side seams are moved 1 cm to the left or right to achieve greater comfort in the waist. The shoulder seams were extended by 3 cm and 1 cm higher and a new sleeve round was formed. In this way, the desired wider width in the shoulder area is achieved.

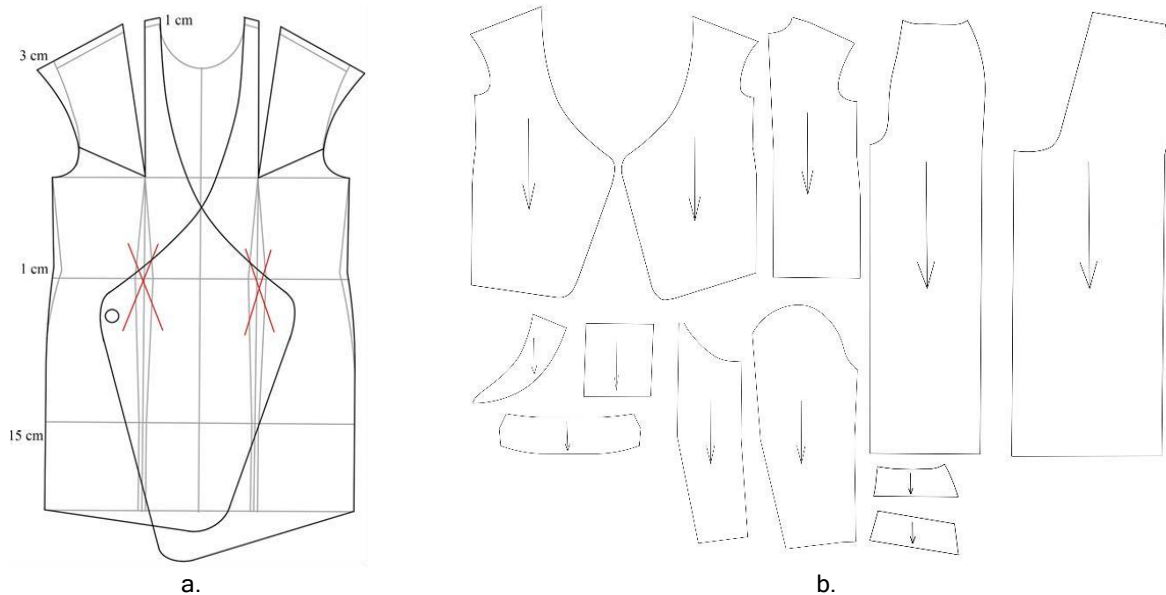

Figure 4: a. Modeling of front part, b. Pattern parts of the selected model [1]

Then, according to the model sketch, the front edges of the jacket fold were created and new lines were obtained. The side seams is widened to avoid narrowing, and the breast placket is located from the shoulder to the depth of the arm. A collar and a sewn pocket were then constructed according to the model sketch. Modeling of the back of the women's jacket began by extending the base pattern measured 15 cm from the cut length line downwards. To achieve greater width at the waist, the side seams are offset by 1 cm. The shoulder seam is extended by 3 cm and 1 cm higher and the placket from the sleeve is transferred to it. The placket on the back of it is removed. To extend the length of the pants, it was measured 3 cm down from the cut length line. According to a sketch of the trousers model, new lines of side seams were created to give a straight cut. The waist height in the waist area was extended by 8 cm.

3. Conclusion

Through research for the purpose of making this paper, it has been noted that social and political developments have greatly influenced the development of women's costume, from its appearance until today. Given the position and role of women in society, women's fashion, up to a point in history, was dysfunctional and conditioned by gender differentiation. With the development of awareness of the importance of gender equality, women's fashion is beginning to change and new outfits are emerging. Speaking exclusively about women's costume as the topic of this paper, it has been noticed through research that men's fashion has greatly influenced its original appearance and the further development of patterns.

References

- [1] Šumanović, S.: Konstrukcija suvremenog ženskog kostima po uzoru na mušku modu 90-tih godina 20. Stoljeća, Bachelor thesis, Sveučilište u Zagrebu Tekstilno-tehnološki fakultet, Zagreb, (2019)
- [2] Csikszentmihaly, M.: Why we need things, In *History from Things: Essays on Material Culture*, Smithsonian Institution Press, ISBN 1-56098-204-7, Washington, (1993), pp. 20-29
- [3] Simončić, K. N.: *Kultura odijevanja u Zagrebu na prijelazu iz 19. u 20. stoljeće*, Plejada, ISBN 978-953-7782-15-3, Zagreb, (2012)
- [4] Cunningham, P. A.; Voso, L. S.: *Dress and Popular Culture*, Bowling Green State University Popular Press, ISBN 0-87972-507-9, Ohio, (1991)
- [5] Troy, N. J.: Paul Poiret's Minaret Style: Originality, Reproduction, and Art in Fashion, *Fashion Theory: The Journal of Dress, Body & Culture*, Berg Publishers, Vol. 6 (2002) No. 2, pp. 117-143, ISBN 0262201402
- [6] Boucher, F.: *20 000 years od fashion: the history of costume and personal adornment (expanded ed.)*, Harry N. Abrams, ISBN 978-0810916937, New York, (1987)
- [7] Palmer, A.: *A cultural history of dress and fashion in the modern age*, Bloomsbury Publishing, ISBN 978-0-8578-5602-9, London, (2017)
- [8] Available from https://www.dior.com/couture/en_hk/the-house-of-dior/the-story-of-dior/the-new-look-revolution Accessed: 2019-05-14
- [9] Chanel costume, Available from <https://www.hungertv.com/wp-content/uploads/2015/08/Coco-Chanel-in-her-atelier-fitting-actress-Romy-Schneider-in-the-1960s.jpg> Accessed: 2019-05-13
- [10] Dior, New Look, Available from https://www.dior.com/couture/var/nfsdior/var/dior/storage/maison-dior/mazarine/images/medias/history/le-new-look/new_look_tailleur_bar_vzq_03.jpg Accessed: 2019-05-14
- [11] YSL, Le smoking, Available from https://s3-eu-west-1.amazonaws.com/musee-ysl-paris/images/max_res/NUM_HC1966H076PH01.01267.jpg Accessed: 2019-05-14
- [12] Available from <https://museeyslparis.com/en/biography/premier-smoking> Accessed: 2019-05-14
- [13] Available from <https://museeyslparis.com/en/biography/premier-tailleur-pantalon-pe> Accessed: 2019-05-14
- [14] Molloy, J. T.: *New Dress for Success*, Warner Books; Exp Updated edition, ISBN 0446385522, New York (1988)
- [15] Mendes, V. & de la Haye, A.: *Fashion since 1900 (New edition)*, Thames & Hudson Ltd., ISBN 978-0500204023, London, (2010)
- [16] Chenoune, F.: *A history of men's fashion*, Flammarion, ISBN 2080135368, (1993)
- [17] Available from <https://www.gq.com/story/most-influential-runway-shows> Accessed: 2019-06-01
- [18] Giorgio Armani 1990., Available from https://media.gq.com/photos/5809253d8931a81f40e68235/master/w_1600%2Cc_limit/1616-GQ-FERU06-04-The%252520Most-Influential-Runway-Shows-Of-All-Time-23.jpg Accessed: 2019-06-01
- [19] Gucci 1995., Available from <https://www.vogue.com/fashion-shows/fall-1995-ready-to-wear/gucci/slideshow/collection#8> Accessed: 2019-06-01
- [20] Ujević, D., Rogale, D. & Hrastinski, M.: *Tehnike konstruiranja i modeliranja odjeće*, Tekstilno-tehnološki fakultet Sveučilišta u Zagrebu, Zrinski d.d. Čakovec, ISBN 978-953-7105-36-5, Zagreb, (2010)

Authors:

Sara ŠUMANOVIĆ, univ. bacc. ing. text., Assist. Prof. Renata HRŽENJAK, PhD. (corresponding author)

University of Zagreb Faculty of Textile Technology

Prilaz baruna Filipovića 28 a, HR-10 000 Zagreb, Croatia

Phone: +(385) (1) 3712 561

Fax: +(385) (1) 3712 599

E-mail: renata.hrzenjak@tff.hr

DESIGNING A KNITWEAR COLLECTION BASED ON MOTIFS AND SYMBOLS OF DYNASTIC CHINA TEXTILES

Valentina FERENČAK; Tena OMEROVIĆ & Vesna Marija POTOČIĆ MATKOVIĆ

Abstract: *This paper explores origins and symbolism of dynastic China motifs as basis for contemporary textiles design. A variety of motifs appears in traditional Chinese textiles such as mythical animals, plants, abstract lines and calligraphic signs. Frequently message was sent by the use of motifs and compositions. Several flowers were preferred, like peony, lotus and chrysanthemum. The most preferred animal motifs were dragon, probably the most powerful symbol in China as well as Korea and Japan, together with unicorn, phoenix, lion, crane, and butterfly. Dragon is used over 2000 years in architecture, textile designs, bronzes, and ceramics. After motifs and colours have been studied, sketches, a range of designs, CAD patterns and samples of fabric were produced. The principal textile-patterning techniques associated with representation of mythical animals of dynastic China are embroidery and weaving. However, contemporary textiles collection is made manipulating techniques of knitting and printing because knitting is less used and therefore novel way of developing classic patterns.*

Keywords: *dragon motif, textiles design, knitting*

1. Introduction

Throughout history, China was known by many things, whether it was by its culture, technology, arts and crafts or manufacture. China had always had an impactful and prosperous way of doing art. Pottery, painting, calligraphy, sculpture, jade carving and textile making are just some of the very well-known Chinese decorative art forms. Chinese art also had a meaning beyond just plain decoration, it was used to portray and celebrate history, to tell stories both mythical and true and to depict the connection between the human and the divine. Ancient Chinese textiles were one of the most appreciated forms of art, where they presented both functionality and the mastery of material treatment, while picturing the rich and deep Chinese history [1]. Even though cotton was also used, the majority of Chinese textiles were made of silk, which is strong, lightweight and naturally lustrous, what made the garments all the more special. Silk was used for thousands of years; it was woven, spun, dyed and crafted in numerous different ways, including beautiful embroidery with ornate designs and patterns [2]. Colours were important as well, where gold, yellow and red indicated wealth, status and divine favour amongst the nobility for instance. Designers usually create collections around a particular theme and typical Chinese symbols, both floral and animal, especially images like clouds, trees, fish, birds, flowers and mountains are perfect source of inspiration. Most commonly used symbols included bamboo, chrysanthemum, lotus flower, magnolias and peonies regarding floral symbols and crane, elephant, fish, peacock, pig, tiger, toad and tortoise regarding animal symbols [3].

2. Research: Flower symbols

To create a collection of textiles it is important to research chosen theme thoroughly, to explore all aspects of the theme. It is important to gather information before sketching of patterns, especially if the role of a motif and color is twofold- visual and symbolic. Flower symbols have a great meaning behind them, every flower has its appropriate meaning and purpose. Flowers are widely represented in architecture, paintings, decorated textiles and porcelain, where the high representation is due because of their ties with nature. Regarding nature elements, a specific flower is almost customarily drawn with a specific bird. Thus the birds like the peacock, fowl and pheasant are pictured with the peony, duck with the lotus, swallow with the willow and stork with the pine or bamboo, as a symbol of longevity. Various flowers and fruit blossoms also symbolize the twelve months of the year as well as represent the four seasons-peony for spring, lotus for summer, chrysanthemum for autumn and lastly, the wild plum for winter. Peony is also considered an emblem of love and affection, and celebrated as a symbol of feminine beauty and an omen of good fortune. The lotus flower shows a great deal of importance to the Chinese, considering the fact that every part of this plant has a name and use. Therefore, it is no wonder its appearance is ubiquitous amongst many Chinese designs, especially those regarding religious paintings and texts, both in Taoism and Buddhism [4]. The lotus serves as a symbol of summer and fruitfulness, and a plethora of stunning lotus designs can be seen in many paintings, architecture, as well as embroidery and carpets. Another national symbol is the chrysanthemum, and it can be regarded as a flower of many names. Some of them being 'the Yellow Button', 'Heaven full of Stars', 'Pine Needles' and 'Dragon

Beard'. Chrysanthemums are generally associated with a life of ease, and depict an emblem of mid-autumn and festivity. And finally, the symbol of the plum, representing winter as one of the four seasons, is regularly noted as a symbol of long life, mostly due to the fact that the flowers and the branches appear lifeless until the tree reaches its mature state. The fact that the plum blossom has been chosen as the 'National Flower' by the Central Political Council shows just how meaningful this symbol actually is. Lastly what feels the need to be mentioned is the significance of tree symbolism. Ever since the ancient times, tree-adoration has been prominent through out China. It is believed that the soul of the god resides inside of trees, therefore making tree symbols sacred in a way. Magic virtues are also assigned to particular tree species. Powers like warding demons off, bestowing immortality or healing all diseases are just some of them, which makes no surprise that plenty of tree motifs can be found in many forms of Chinese art [3, 5].

3. Research: Animal symbols

Animal symbols demonstrate even further fascination and admiration. A myriad of animals are mentioned on the pages of many books and text, showcased on paintings, scrolls, textiles and porcelain. Chinese artists drew inspiration from tiny ants and cicadas to tremendous elephants, or even beasts like lions and wolves. The relevance of animal symbolism is also shown by the fact that the Chinese zodiac exhibits twelve animal guardians- each of them having a special meaning. Animals are a commonly used form of symbolism, because it was believed since the ancient times that they have the ability of distinguishing good from evil. It was also taught that humans and animals serve as integral parts of nature, both sharing the same moral principle. Some of them used more often - ants, badgers, bats, bees, butterflies, carps, cats, cicadas, crabs, deers, dogs, donkeys, dragonflies, elephants, fish, foxes, hares, horses, lions, monkeys, panthers, pigs, rats, sheep, snakes, spiders, tigers, toads, tortoises and wolves [4]. Insects like ants stand for hard work and order, displaying righteousness and patriotism. Dragonflies serve as an emblem of summer and represent fleeting moments. It was used as a symbol of purity and is hence fore often paired with the pure white lotus flower. The spider is considered a lucky creature by the Chinese. Spiders dangle on their webs and gravitate towards the ground, what symbolizes good fortune descending from the heavens. Motifs of beasts such as lions and leopards were primarily reserved for the robes and court robes of military officials [5]. The leopard (or a panther) is considered an emblem of bravery and it therefore exists on the robes of the third grade military officials, whereas the lion persists on the court robes of the second grade officials [5]. The lion is not indigenous to China, but due to his status as the 'King of Animals', it stands for valour, energy and wisdom. Even though the lion is not as highly appreciated as the tiger for instance, sufficient lion statues adorn sacred buildings, like Buddhist temples, and even some of the Buddhist deities are sometimes shown mounted on its back. Tigers were such a common symbol in ancient times, and are still very much found in contemporary Chinese art. A tiger is regarded as the king of wild beasts, and it stands for sternness, dignity, courage and vigilance, all of the main characteristics of a soldier. It was also painted on the shields of soldiers and embroidered upon court robes of various grades of military officers. The tiger is also figured on numerous bronzes dating in ancient times, as well as an ornament on the sides of bronze and porcelain [6]. The tiger has the ability to ward off evil spirits and engrave a special sort of terror to demons, and it was therefore painted on walls of houses and temples as well as embroidered on shoes for small children. Another rather peculiar animal symbol is the peacock. A bird of conspicuous and beautiful feathers is shown great respect and admiration. The peacock is an emblem of beauty and dignity, and its feathers were even given as a reward for a contribution to charity. The only other bird that is shown greater admiration is the crane. The crane is the most celebrated bird in Chinese legends, where is endowed with abundant mythical abilities. It is expressed as the prevalent emblem of longevity, often paired with the pine tree, also a symbol of age and maturity. It comes in four colours - black, white, yellow and blue, where the white crane was usually embroidered on the court robes of civil officials of the fourth grade [2].

In addition to other animal symbols, it feels imperative to mention the fish symbols. From an aesthetic point of view, fish are tremendously appreciated by the Chinese. Copious dazzling and superb variations of gold fish are depicted on jars, with carp and perch frequently illustrated on Chinese porcelain. Symbolically speaking, the fish is employed as an emblem of abundance and wealth, but simultaneously being a symbol of regeneration and harmony as well. Regarding the fact that fish usually swim in pairs, a couple of fish is reflected as the joy of union and a charm used to ward of malicious spirits. Even though regular animals are omnipresent in Chinese symbolism, mythological beings such as dragons, unicorns and phoenixes do not pose as strangers. Dragon, unicorn and phoenix, alongside tortoise as well, are considered 'the four spiritually endowed creatures', according to the „Book of Rites“, one of the Five Classics of the Confucian canon, a book of significant influence in Chinese history and culture. The tortoise is treated as a sacred symbol, where it symbolizes the universe because of its dome-shaped back (which represents the sky) and its belly (which represents the earth) and is therefore regarded as an emblem of longevity, strength and endurance. Following with the unicorn, the unicorn is considered a symbol of longevity, grandeur and felicity. It is also believed that the unicorn represents utmost benevolence, and it is considered an emblem of pure goodness but it

appears to mankind only when the most compassionate king rules the throne. Therefore, it was used only for virtuous rulers and was also formerly embroidered on the court robes of the military officials of the first grade [2].

The phoenix presents itself as the most honourable amongst the feathered creatures, even more than the peacock and the crane. Along with the unicorn, it does not feed on living creatures and is henceforth very much accepted by Buddhists, who follow a compassionate and altruistic way of living. It is a symbol of peace, prosperity and warmth. As a decorative motif, it was employed in ceremonial costumes, formerly worn by non other than the Empress of China herself. Sometimes it was also used as decorative ornamental piece for a lady's head-dress. And lastly, what feels like the most crucial and essential symbol of all, the dragon. The dragon is China's oldest mythological creature [7]. Dragons were believed to be the spirits of change, embodiments of strength and goodness. According to the legends, a dragon is the leader of all scaly creatures- lizards, snakes and fish, and it holds the power of transformation. There are three species of dragons, the ones that inhabit the sky, those who live in the depths of the ocean and those who reside in marshes and mountain dens. They are usually illustrated with no wings, with fangs and teeth of a carnivore, body of a snake, with four clawed legs and whiskers on its face. Dragons are featured as ornaments in architecture, art design and fabrics in various forms. One of the varieties is the Kui-dragon, a primitive dragon that primarily embellishes ancient Chinese bronzes, another is the Celestial dragon, which serves as a protector of mansions of the gods, furthermore the Spiritual dragon, which bears rain and wind, then the Dragon of Hidden treasures which protects and conceals wealth and many, many more [8]. The dragon is seen as an emblem of diligence and safeguard and it is deemed as a benevolent keeper of all treasured things. As it is credited as symbol of male vigour and fertility, the dragon is also a symbol of the Emperor, also known as the Son of Heaven [2, 9]. It is considered an amalgam of various animals [10]. Numerous Chinese paintings repeatedly show dragons playing in the clouds or holding large pearls, making them furthermore the most complex and multi-tiered Chinese symbol [3, 5, 11].

4. Research: Colours

Even though so much meaning goes behind floral and animal motifs, colours have a very important meaning and purpose in Chinese symbolism. All colours appear to be brilliant and loud, sometimes striking to the limit of kitsch. They are seen as emblems of rank, authority, virtue, emotions such as joy and sorrow and a plethora of others [5]. The Chinese colour theory is based on the Five Elements theory, a theory deeply engraved in Chinese culture, those five elements being metal, fire, water, wood and air, respectively. According to the Chinese gradation, there are five primary colours- red, yellow, blue, white and black. Red is considered a regal colour, as well as an emblem of joy and gleefulness and is therefore worn on all merry and festive occasions. It is also a popular colour and it symbolizes luck and happiness. Red is also represented by the element of fire, and is hence believed that it wards off evil, celebrates vitality and brings fertility and good luck to an individuals' household. Red is also the traditional colour worn by Chinese brides, in opposition to the Western white wedding dress. Yellow is regarded as a national colour, represented by the earth element, and an imperial colour in traditional Chinese colour symbolism, formerly sacred to the Emperor. It represents power, royalty and prosperity. Because of its warm and bright tone, it also represents summer. Blue is the symbol of immortality and advancement, and odd as it sounds, it is represented by the wood element. Because of its cool tone, it also represents spring. Light blue was sometimes referred to as the celestial colour, in Buddhist images, because it was the representation of the sky. Totally different than Western traditions, white is associated with death and it is the colour of mourning. It embodies purity and innocence and it brings a sense of renewal. It is represented by the element of metal. The colour represented by the element of water is surprisingly enough-black. Its reputation is similar to that of the Western culture, whereas it is not viewed as one of the happy colours in traditional Chinese symbolism. It epitomizes cruelty, sadness and destruction, it even stands for bad luck and irregularity. And lastly, the colour that is not represented by one of the five elements, but is equally important, is gold. Gold was believed to be the colour of eternal light, and also equates wealth and prosperity, in both Chinese and Western culture alike [11, 12].

5. Development of contemporary knitwear collection: working with color, motifs and production technologies

After identity and culture, motifs and colours of Chinese motifs have been studied, sketches were developed. Sketches were progressed into concept of knitted fabric which included color palette, texture and pattern ideas. Ultimately a range of designs that can be translated into knitwear were produced. Technical details, CAD patterns and samples of fabric were produced (fig. 1-5).

Instead of traditional textile-patterning techniques such as embroidery, silk tapestry weaving and brocade weaving, the contemporary collection is made manipulating techniques of knitting and printing. The focus of the collection is a fusion of two kinds of pattern making, patterns made by knitting are completed, finished with printed details. The knitting and printing methods were used because knitting is often neglected, less used and therefore fresh way of developing classic patterns. Knitwear design is especially rewarding because of its flexibility and versatility. Goal of combining two ways of making patterns is to give the collection a modern spin on otherwise classic Chinese motifs and colours. Novelty in aesthetic is important in increased competition in market. The knit pattern is achieved through electronic Jacquard, a form of computerized jacquard that uses circular or flat knitting machines to create various fancy patterns and stitches. The computer interface makes the pattern designing quickly and simply [13]. Pigment print is administered later onto a sample made via jacquard knitting. Direct pigment print is one of the most known, most popular and oldest techniques of direct printing. In pigment printing, insoluble coloured pigments (which do not possess natural affinity towards textile fibres) are bonded and fixated to the textile material with the help of binding agents. Since pigments attach to fibres mechanically, they are ideal for printing various fibres regardless of their type. From the design standpoint, different levels of interaction between knit pattern and print pattern are explored within the collection. It includes a range of pattern integration starting from knit pattern dominant design to print pattern dominant design. The main goal is to ensure that patterns compliment and enrich each other without clashing or seeming detachable thus providing a single picture of one whole inseparable design pattern [14].

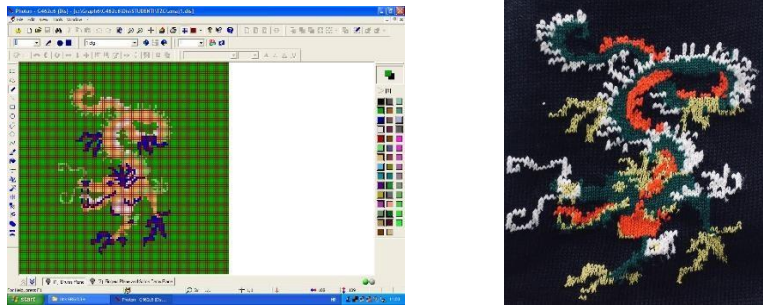

Figure 1: Dragon pattern 1; a) CAD pattern; b) produced textile sample

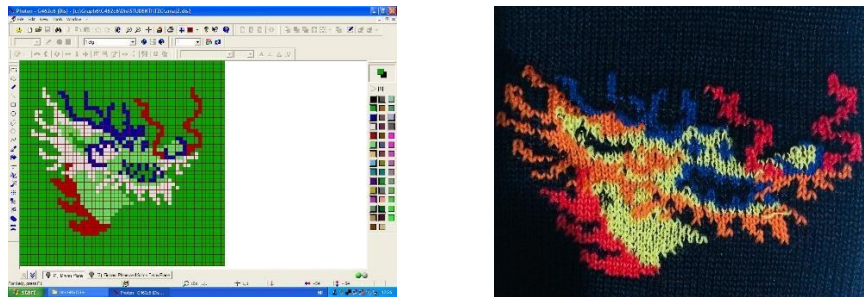

Figure 2: Dragon pattern 2; a) CAD pattern; b) produced textile sample

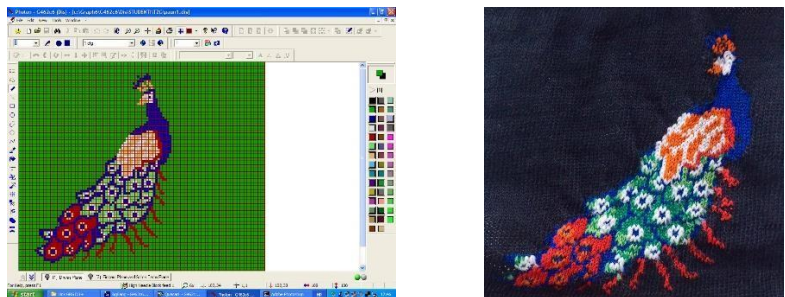

Figure 3: Peacock pattern; a) CAD pattern; b) produced textile sample

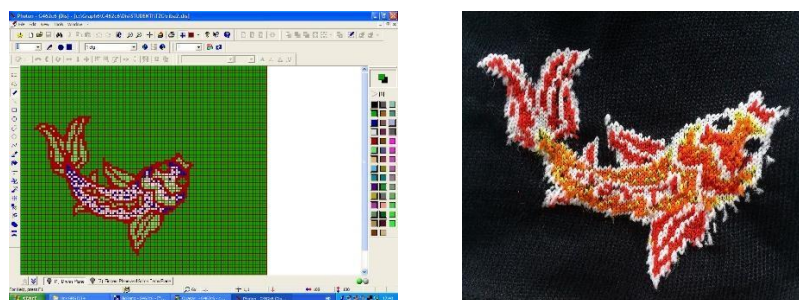

Figure 4: Fish pattern 1; a) CAD pattern; b) produced textile sample

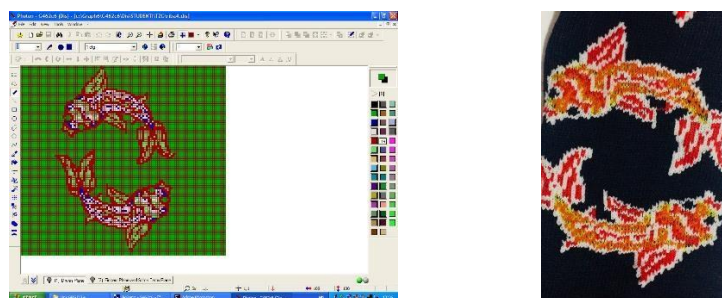

Figure 5: Fish pattern 2; a) CAD pattern; b) produced textile sample

6. Conclusion

Typical Chinese motifs, both floral and animal, proved to be perfect source of inspiration. Chosen theme was researched thoroughly with the aim of accurate and precise use of symbolism, motifs and colors. Instead of traditional textile-patterning techniques such as embroidery and weaving, the contemporary collection is made manipulating techniques of knitting and printing. Knitting with print details are less used and therefore fresh way of developing classic patterns. Developed textiles collection is designed for commercial company or individual client. Textiles are intended for casualwear. They are suitable for Autumn/Winter season, predominantly for teenwear and womenswear.

References

- [1] Rawson, J.: *The British Museum Book of Chinese Art*, British Museum Press, 978-0714114538, London, (1992)
- [2] Hann, M. A.: *Dragons, Unicorns and Phoenixes - Origin and Continuity of Technique and Motif*, University Gallery Leeds, 1-874331-32-4, Leeds, (2004)
- [3] Williams, C.A.S., In *Chinese symbolism & art motifs*, Tuttle Publishing, 978-0-8048-3704-0, Hong Kong (2006), pp. 118-120; 145-154; 192-195; 198-200; 250-251; 253-256; 307-308; 310-311; 313-315; 319-321; 377-386; 390-393.;
- [4] Zhong, H.: *The Patterning of Qing Dynasty Textiles – A Case Study of the Clothworkers*, University of Leeds, Leeds, (1989)
- [5] Hann, M. : The visual arts of dynastic China, In *Symbol, Pattern & Symmetry*, Bloomsbury, 978-0-8578-5488-9, London, (2013), pp. 268-285
- [6] Hearn, M.; Fong, W.: The Arts of Ancient China, *The Metropolitan Museum of Art Bulletin*, 32, (2), (1974), pp. 230-282
- [7] Walters, D.: *Chinese Mythology: An Encyclopaedia of Myth and Legend*, Diamond Books, 978-0261666573, London, (1995)
- [8] Carr, M.: Chinese Dragon Names, *Linguistics of the Tibeto-Burman Area*, 13 (2), ISSN 0731-3500, (1990), pp. 87-189
- [9] Wilson, J. K.: Powerful Form and Potent Symbol: The Dragon in Asia, *The Bulletin of the Cleveland Museum of Art*, 77 (8), ISSN: 00098841, 286-323, (1990), pp. 18
- [10] Allane, L.: *Chinese Rugs*, Thames and Hudson, 978-0500277010, London, (1994), pp 107.
- [11] Available from: <https://www.chinasage.info/symbols/animals.htm>, Accessed: 23.02.2020.
- [12] Available from: <https://bigchill.com/us/blog/8-colors-symbolism-chinese-culture/>, Accessed: 23.02.2020.
- [13] Lasić, V.: Višebojna pletiva, In *Vezovi pletiva*, Vladimir Lasić, 953-97402-0-7, Zagreb, (1998), pp. 35-41

- [14] Donofrio-Ferrezza, L.; Hefferen, M.: *Designing a Knitwear Collection*, Fairchild Books, 978-1-56367-492-1, New York, (2008), pp. 181-249

Authors:

Valentina FERENČAK

University of Zagreb Faculty of Textile Technology

Prilaz baruna Filipovića 28a, 10000 Zagreb, Croatia

Phone: +(385) (1) 3712573

Fax: +(385) (1) 3712533

E-mail: vferencak@ttf.hr

Tena OMEROVIĆ

University of Zagreb Faculty of Textile Technology

Prilaz baruna Filipovića 28a, 10000 Zagreb, Croatia

Phone: +(385) (1) 3712573

Fax: +(385) (1) 3712533

E-mail: tomerovic@ttf.hr

Vesna Marija POTOČIĆ MATKOVIĆ (corresponding author)

University of Zagreb Faculty of Textile Technology

Prilaz baruna Filipovića 28a, 10000 Zagreb, Croatia

Phone: +(385) (1) 3712573

Fax: +(385) (1) 3712533

E-mail: marija.potocic@ttf.hr

LEATHER FURNITURE CUTTING ROOM – INDUSTRY 4.0 WITH LECTRA VERSALIS

Ivan KATIĆ & Slavenka PETRAK

Abstract: *Leather is unique distinctive product and a luxurious choice to refine upholstery covering by centuries. Today it remains a noble material with natural-tough-chique look and feel, valorized by customers in search of exclusivity. As a premium material, leather is precious and we need to optimize its use to answer growing customer needs. Manufacturers face strong pressure on price due to increasing competition, especially online. Leather cutting is still heavily manual and although demand remains stable, the cost of labor is increasing due to a decrease in the number of skilled workers, and that is a challenge in an area where skills are a key element in output quality and ultimately, in the company's performance. This paper presents Lectra solution for leather furniture cutting room fully prepared for industry 4.0.*

Keywords: *Leather, Furniture, Cutting room, Industry 4.0, Lectra*

1. Introduction

Leather is a material that has accompanied mankind throughout history. Originally, furs and hides of captured animals gave protection from cold and humidity in the form of blankets, clothing, shoes or boots. Leather was also used for tents, kayak boats, belts or leather vessels [1]. All this time constant development of leather treatment techniques, tools and methods have been going on. From stone knives and bone needles, technology evolved into high-tech industrial cutting machines. Industrial leather processing serves the purpose of mass production of leather items to satisfy the growing demand, especially in furniture and automotive productions. This demands from technology to be economically efficient, fast, adaptive and to provide maximum possible results with minimum possible cost [2].

2. Trends in the furniture market

According to statistics from 2018, about 32% of all upholstered furniture sold worldwide is covered in leather, Fig. 1. There is a steady increase in the quantity of leather produced worldwide used in the furniture industry, which was at 5% in 1990, and has raised up to 13,5% in 2010 [3], thus becoming the second biggest end user of leather, Tab. 1. Global furniture market is on the rise representing 74BN+ (+22% over 10 year period 2008 > 2018). In the production of upholstered furniture, 5 nations rule over a concentrated world. China has grown to almost 50%, as nations like the US are gradually losing ground. Western European countries also lost relevance except for Italy who managed to limit the damage thanks to its higher end expertise. Poland, and more recently India have benefited from this switch of fortunes, Fig. 2.



Figure 1: Upholstery production per used material

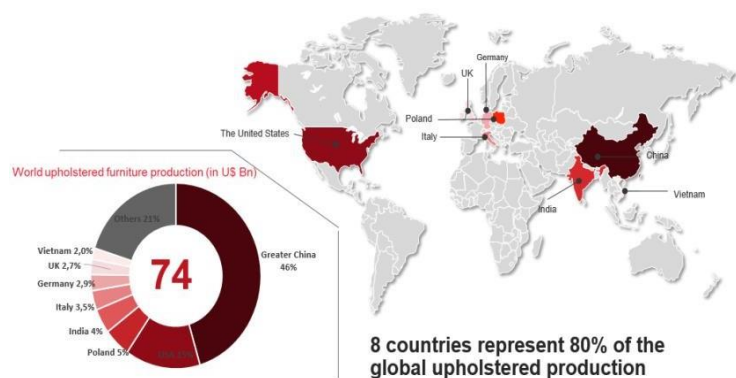

Figure 2: World upholstered furniture production

Table 1: Leather end uses in percentages based on square feet consumed [3]

	Footwear	Clothing	Gloves	Leather goods	Furniture	Automotive
1970	50-70	3-5,0	3-5,0	15-20	No data	No data
1990	67,9	12,4	4,3	8,8	5,0	1,6
1995	62,6	17,8	4,2	8,7	4,8	1,9
2000	58,0	14,6	4,3	9,4	8,8	4,9
2005	55,0	11,4	4,4	9,2	13,0	7,0
2010	53,3	11,4	4,3	9,1	13,5	8,2

Sources: ITC and industry

What all this means is that an increase in consumer wealth leads to a rise in the demand for leather for premium goods. In turn, this means an increase in sales of luxury goods, leather furniture, and upholstery leather for automobiles, Fig. 3 [4]. Increasingly important in this calculation is the fact that, in much of Asia, growing wealth combined with the specific local demographics (one-child families, multiple generations sharing housing) produces a rapid increase in disposable income. Add to this the traditional Asian preference for premium brands, and the conclusion is that the purchasing of high-quality leather goods is likely to continue rising at a higher rate in Asia than in the rest of the world for many years to come.



Figure 3: Global luxury furniture market by end user [5]

Global trends that currently shape the leather furniture market:

- Furniture market is racing to go digital and millennials drive consumption
- Digital Revolution of furniture market from brick & mortar shops to the online market
- An increasing number of pure players have disrupted the furniture marketplace with a new connected and digital approach
- Fast-fashion collections boost home furniture turnover and production leads to “made to order” production model
- Growing upmarket demand boosted by raising GDP standard of living of emerging countries for higher end interiors is an opportunity of Leather made furniture
- China has emerged as the biggest and fastest developing furniture market in the Asia Pacific, highly driven by the growth in living standards and disposable income.
- Leather remains distinctive and valorized as natural and noble product compatible with the eco-conscious growing trend

3. The necessary manufacturing digital evolution

Cow hide is the number one choice for leather furniture. A large furniture set will require between 6 and 7 cow hide skins. In upholstery only better quality hides can be used, Fig. 4 and Fig. 5 [6], and therefore it is essential to achieve the smallest possible amount of cutting waste. Leather is sold by surface and cutting waste increases costs. In the furniture sector, waste is generally between 30 and 45% [1]. As a premium material, leather is precious and it is necessary to optimize its use to answer growing customer needs. Manufacturers face strong pressure on price due to increasing competition, especially online.



Figure 4: Worldwide leather supply usage

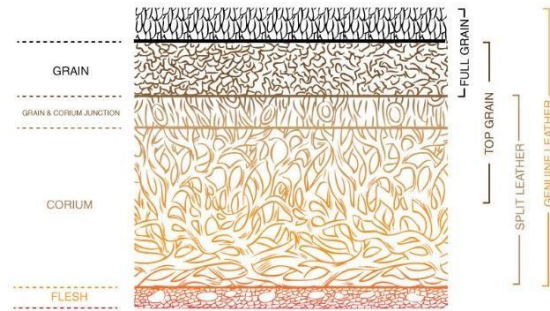

Figure 5: Leather grain separation

There are few key points that are putting pressure on luxury furniture manufacturers to upgrade their production processes and go digital:

- Upholstered furniture manufacturers (residential and commercial) have increasing needs for mass customization, growing quality standards, smaller productions, the fast delivery, affordable price.
- Leather cutting is still heavily manual and based on skilled operators experience, generating variability on the production in terms of material usage and quality, and that is significantly impacting costs.
- Around the cutting process itself, manufacturers need support to optimize the overall production flow, from order planning, stock management, cutting operation follow-up, quality control and bundling for sewing, basing their improvements actions on data analysis and expertise.
- Process modernization and optimization are key to meet these challenges and furniture manufacturers will need to find a way to upgrade their cutting room to the digital era, to reach higher efficiency, reduce time to market and reduce costs.
- The upholstered furniture market has room to grow, to modernize and adopt technology towards the industry 4.0 revolution

These new market drivers involve new challenges for manufacturers. Since consumers are impatient, they have to deliver furniture faster and accelerate their time to market. Also, consumers want it at an affordable price so manufacturers have to cope with downward pressure on prices. Then, to respond to demands for customization and design products, manufacturers have to manage an increasing diversity of models. And finally, they have to respond to higher standards by supplying higher quality and eco-friendly products. So to overcome these challenges, manufacturers need to:

- Reduce time to market
- Anticipate and reduce costs to increase margins
- Increase efficiency in manufacturing
- Be able to improve product quality

According to the Centre for Industrial Studies (CSIL), to reach these goals, upholstered furniture manufacturers from European region have decided to take different actions:

- They are going to optimize their manufacturing process, to reach higher efficiency, reduce time to market and reduce costs.
- European manufacturers have decided to upgrade their cutting solutions
- They have decided to rely on design and product development to succeed.
- Finally, they will train their labor force to also reduce their time to market and increase the quality of their products

According to the study, upholstered furniture manufacturers from the European region have decided to invest 52% more to expand their productive capacity. So, it is clear that European upholstered furniture manufacturers consider productive capacity expansion a key element in their strategy to face new challenges and reach their goals [7].

4. Leather cutting process

Whether it's car leather, furniture, clothing or for shoes, leather has to be cut first. Leather skin has a non-uniform outer contour, there are defects in the leather and not all areas of the skin are of the same quality or have the same grain pattern. That's why the art of cutting leather lies in the optimal area yield while taking all

these aspects into consideration. Leather cutting process is divided into few separate stages; hide marking for damages and quality zones, Fig. 6, nesting, Fig. 7, and cutting. A cutter must check the skin on both sides for defects. These can be colour defects or damages in the skin. Cutting lines must be chosen in such a way that the finished objects have a similar grain pattern. A cutter must select the better parts of the hide for the areas of upholstery that will get the most use, like seats and armrests. This must all be done while ensuring the smallest possible amount of cutting waste [1]. This process is called nesting. Nesting in the leather industry is a complex challenge of placing a set of irregularly shaped pieces known as templates on a plane irregularly shaped surface, such that no templates overlap and that the cutting waste produced when cutting out the templates is minimized. Manual nesting process has many shortcomings that result in low productivity and low efficiency. In the mass manufacturing of leather furniture, saving of materials is very important as material cost is the major portion of the overall production cost. With the use of automation, more efficient nesting and cutting productivity are achieved [8]. This performance is independent of operator experience and skills, and reducing investment in training and labor. Once nesting is done, it can be used only one time on that particular hide for which it was prepared, and the process starts all over again with each new hide.

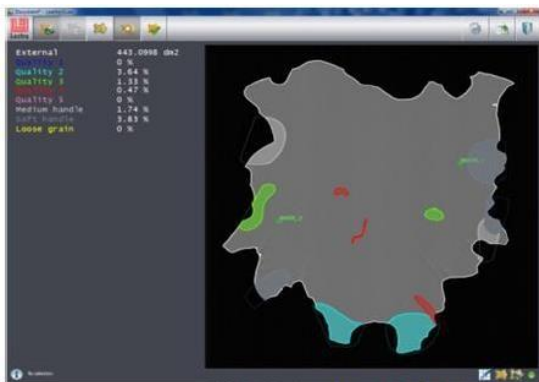

Figure 6: Marked hide with damages and quality zones

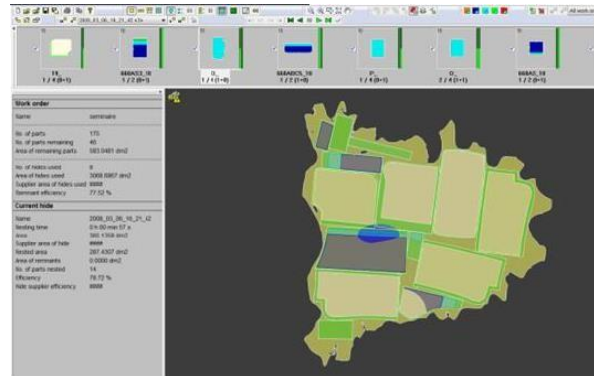

Figure 7: Nested hide

Leather cutting is still heavily manual and although demand remains stable, the cost of labor is increasing due to a decrease in the number of skilled workers. And that is a big challenge in an area where skills are a key element in output quality and ultimately in the company's performance. Tools used in mechanized leather cutting can be die press, blade, waterjet and laser. Die press is the most traditional way of leather cutting. Although cutting quality achieved by presses is quite good, it fails in all other aspects compared to other tools. It has a high cost in labour and for each new template, new molds must be produced. It is inefficient in material savings and productivity per operator. Water jet cutting, laser cutting and CNC knife cutting tables were applied in leather cutting applications relatively recently, in the late '90s and '00s. This development allowed the application of automatic vision based systems for inspection, distribution and optimization of cutting procedure.

5. Lectra Integrated Leather Solution – Versalis Furniture

With 40 years of experience in electronics, and more than 10 years in connected solutions and as a pioneer of the Internet of Things, Lectra's answer for future leather cutting challenges is called Versalis. Versalis is the latest generation CAD/CAM system in an All-In-One integrated cutting line for Leather. It is an advanced digital leather cutting solution that will ease the manufacturer's transition into Industry 4.0. Versalis revolutionizes the leather cutting process. Developed over years of experience partnering with manufacturers, Versalis helps to improve the product development process, optimize material consumption and maximize cutting room performance. Versalis makes the entire production cycle more efficient and improves long-term competitiveness with its dedicated software suite, equipment and Professional Services. Lectra has developed best practices for implementing cutting solutions and accelerating the learning process, thus ensuring optimum use of its systems from the very beginning. There are several configurations available, depending on the production method, hide type and leather quality. Versalis furniture powerful leather nesting algorithms optimize material consumption and suggest in seconds the best nesting for each hide. Lectra has created a completely integrated, end-to-end solution specifically to meet the particular needs of furniture companies using leather. From design, product development, manufacturing and analysis of the production results [9]:

Prototyping: Design Concept 3D for product validation

- Prototyping
- Product validation
- Material consumption
- Leather costing

Product development: Design Concept 2D/Formaris for Manufacturing

- Technical specifications
- Quality zones
- Pattern industrialization

Manufacturing: Versalis Cutting Room for the complete cutting process

- Cut preparation
- Digitalization
- Nesting
- Cut execution
- Offloading

Optimization: Leather Reporting for production monitoring to analysis in order to optimize the production process leveraging data exploration

- Production control
- Key performance indicators
- Optimization powered by data intelligence

In this paper we will concentrate on the manufacturing stage of the process, Versalis cutting room. There are three major configurations: online monoconveyor, online multiconveyor and offline multiconveyor. Type of the configuration is linked to the quality of leather that the manufacturer uses, Fig. 8. Online monoconveyor configuration is used for pre-marked corrected split leather and it's not typically used in furniture manufacturing. This machine has one conveyor that drives hide through all stages of the process, and it's designed for high productivity. For this configuration, damages and quality zones on the hides are pre-marked. Hide is then positioned on the machine conveyor and driven through the scanner. After scanning, hide arrives to the nesting area. Nesting is done automatically, and time allowed for nesting is dictated by cutting time. Nested hide then moves to the cutting area. Versalis for furniture can have 1 or 2 cutting heads. One head machines are used for cutting big parts, while two head machines are used for cutting smaller parts. Tools used for cutting are blades and depending of the type of production they can be high quality blades or high speed blades. After cutting hide is moved to offload area from which parts are sorted. Online multiconveyor configuration is used for cutting higher quality leathers. Hide is positioned on the digitizing station, and marking of damages and quality zones is done directly on the machine. This machine has three conveyors, that allow stages of the process to be independant, so that digitizing time is not dictated by cutting or offloading time. After digitizing, the process is similar to monoconveyor configuration; nesting, cutting, offloading.

Offline multiconveyor configuration is especially efficient and is used for cutting the highest quality leather. In this configuration, digitizing stations are physically separated from the cutter. That allows the manufacturer to digitize all the hides on stock before nesting process. During nesting, software algorithm will run through all digitized hides in order to find the most efficient nesting result.

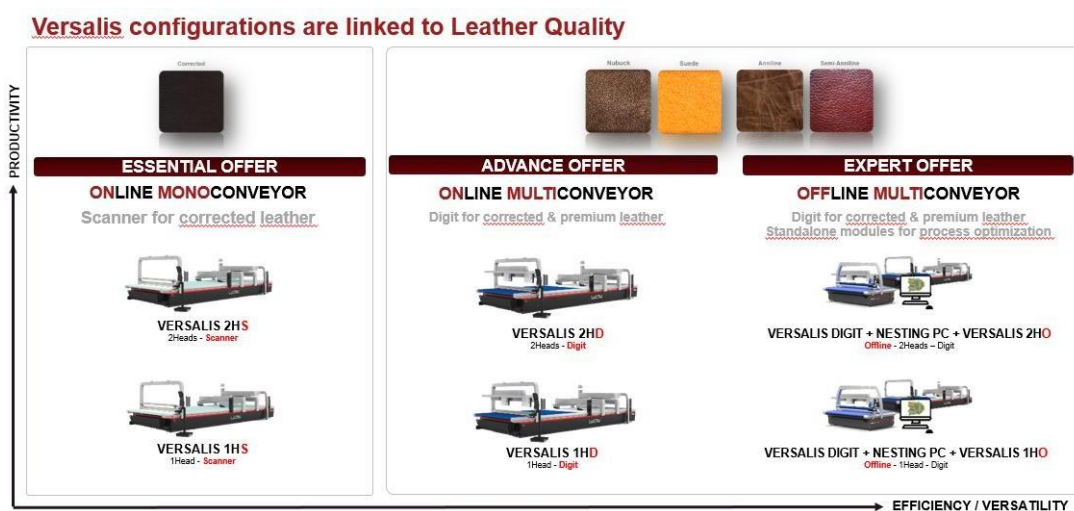

Figure 8: Versalis configurations according to leather quality

Nesting station is a separate entity, and nesting can be done anywhere, even at remote locations. This is useful if design and development of products are done in one location, and manufacturing is somewhere else. When nesting is done, hides required for cutting are positioned on the machine with the help of a projector. At

that time it is possible to manually correct nesting if needed. Cutting and offloading processes are the same as in the other two configurations. The process itself is divided into 5 stages: preparation, digitalization or scanning, nesting, cutting and offloading. Preparation of leather is done for online monoconveyor configuration. It is process in which the operator is defining quality zones and checking hides for damages. They are marked with a special pen or coloured chalk. This is done only for monoconveyor configuration. Scanning is a stage in which pre-marked leather is being scanned for nesting. This is also used only in monoconveyor configuration. Digitalization is a multiconveyor configuration first stage of the process. It can be online or offline. In online configuration, the digitizer is a part of the machine, and digitized hide has to go to the nesting process immediately after digitizing. In offline configuration, the digitizer is a separate entity, and all hides on stock can be scanned before nesting, thus ensuring the absolute maximum of efficiency. Nesting stage can also be online or offline. On monoconveyor machines and on multiconveyor online machines, nesting is done on the machine immediately after scanning/digitizing. On offline machines, nesting is a separate entity and can be done independent of digitizing or cutting stage. Cutting execution on Versalis is done by blades and drills. Blades can be high quality or high speed. Versalis furniture can have 1 or 2 cutting heads. Each cutting head has two drill holders, in which can be mounted drills diameter 1 to 5 mm. Versalis is able to cut with 0mm buffer between pieces. The offloading station is used for picking up cut parts and sorting them. Sorting is assisted by the monitor on which cutting job is displayed, or can be projected directly on the hide, which is more ergonomic but also more expensive option. The operator on offload has an option to discard cut piece if the quality is not good, and to immediately assign this piece in the batch list for next hide of the same color/type.

Lectra Versalis Furniture solution is fully compliant with industry 4.0 and is connected to the Internet of Things (IoT). Versalis is a data-driven system powered by more than 250 embedded sensors for real-time process and cost control. Data intelligence monitors and optimizes overall leather cutting operations. System interfaces guarantee seamless integration into the manufacturer's IT environment. Additionally, Versalis is covered by extensive support which includes online remote support, on-site support, preventive maintenance, predictive maintenance and software evolution. Production reporting is available in real time and from remote devices.

6. Conclusion

Versalis Furniture leather cutting solution provides the production flexibility needed to handle increasing model variability and complexity on smaller batches. The ability to cut new models at will, without uptime interruption, eliminates retooling costs and lead-times. With an integrated production flow from work order preparation to the offloading of cut parts, a single Versalis cutting line offers the same productivity as a labor-intensive die-press environment with 4 nesting tables. Versalis automates and standardizes leather cutting line with automated scanning, nesting and cutting operations using a single integrated solution from cut preparation to hide digitization to the offloading of cut parts. Automation at every step minimizes variability by reducing the risk of human error.

References

- [1] Rausch J.: Leather dictionary, Available from https://www.leatherdictionary.com/index.php/The_Leather_Dictionary Accessed: 2020-02-22
- [2] Stepanov A. et al.: Laser cutting of leather: tool for industry or designers?, *Physics Procedia* 78 (2015) 157 - 162, 15th Nordic Laser Materials Processing Conference, Nolamp 15, 25-27 August 2015, Lappeenranta, Finland
- [3] United Nations Industrial Development Organization UNIDO: Future Trends in the World Leather and Leather Products Industry and Trade, Vienna 2010, Available from https://leatherpanel.org/sites/default/files/publications-attachments/future_trends_in_the_world_leather_and_leather_products_industry_and_trade.pdf, Accessed: 2020-02-21
- [4] Kral I.; Schmel F.; Buljan J.: The future of leather, United Nations Industrial Development Organization (2014), Available from http://leatherpanel.org/sites/default/files/publications-attachments/future_for_leather_final.pdf, Accessed: 2020-02-21
- [5] Chaudhari S.:Luxury Furniture Market, Available from <https://www.alliedmarketresearch.com/luxury-furniture-market>, Accessed on 2020-02-21
- [6] Inesoi: A Comprehensive Guide for Buying the Best Leather, available from <https://blog.inesoi.com/a-comprehensive-guide-for-buying-the-best-leather.html>, Accessed: 2020-02-21
- [7] European Commission: The leather industry in the EU, Available from https://ec.europa.eu/growth/sectors/fashion/leather/eu-industry_en, Accessed: 2020-02-21

- [8] Elamvazuthi I., Kamaruddin S., Shahrul Azmi M.: Automation of Nesting and Cutting Processes of Leather Furniture Production: A Case Study, *International Journal of Mechanical & Mechatronics Engineering IJMME*, Vol: 9 No: 10
- [9] Lectra official website available from <https://www.lectra.com/en> Accessed: 2020-02-22 Versalis® is a registered trademark of Lectra

Authors:

Ivan KATIĆ (corresponding author)

Lectra Deutschland GmbH, Glavna podružnica Zagreb
Buzinski prilaz 10, 10000 Zagreb, Croatia
Phone: +(385) (99) 3145362

E-mail: i.katic@lectra.com

Prof. Slavenka Petrak, PhD.

University of Zagreb Faculty of Textile Technology, Department of Clothing Technology
Prilaz baruna Filipovića 28a, HR-10000 Zagreb, Croatia
Tel: +(385) (1) 3712 543 Fax: +(385) (1) 3712 599

E-mail: slavenka.petrak@ttf.unizg.hr



The Doctoral Students' Section (DSS)

ORIGINAL SCIENTIFIC PAPERS

KNITTING SHORT SOCKS WITH SIRO AND MODAL YARNS

Tea JOVANOVIĆ; Željka PAVLOVIĆ; Miloš LOZO & Zlatko VRLJIČAK

Abstract: Plain socks can be men's, women's or children's. They are essentially made from three yarns. The base yarn is most often cotton or woollen, single or ply, or one of many other yarns with similar shape and fibre composition. Various plain socks which have special uses are developed using the same construction principles as classic plain socks. Therefore, socks for skiers, football, handball, basketball and tennis players are made according to predefined principles with some yarns that have special properties being knitted into certain sock parts. There is a continuous search for the most suitable yarns and yarn properties for all of the above mentioned and similar shapes of plain socks. The focus of this research is on the production of classic winter plain socks with viscose SIRO yarns and modal fibre yarns. Sock samples were made using hosiery machine with a cylinder-bed diameter of 95 mm (3 ¾ inches) which knitted with 108 needles, i.e. it had the E9 gauge. On this type of machine, up to five yarns with total yarn count of 50 to 100 tex are optimally knitted into a row. The described yarns were used to make three samples per each type of plain sock with different base and plated yarns. The base yarns had the yarn count of 20 and 25 tex, the plated PA 156 and 220 dtex and the elastane 54 tex. The masses of produced socks were 19.3 to 23.0 g/pc.

Keywords: classic winter plain socks, modal, viscose, SIRO, polyamide, cotton

1. Introduction

Plain socks can be men's, women's or children's. They are essentially made from three yarns. The base yarn is most often cotton or woollen, single or ply, or one of many other yarns with similar shape and fibre composition. This yarn participates in the sock from 60 to 90%. It carries the sock structure and is inserted into almost all parts of the sock. Such base yarns have small breaking elongation, which is usually 3 to 10 %, and do not provide the necessary sock elasticity. To obtain the necessary sock elasticity or yarn contraction when the sock is pulled onto the leg and used, apart from the base yarn, polyamide multifilament yarn is inserted. This yarn is plated with the aim of reinforcing the structure, particularly yarn contraction. Polyamide multifilament yarns that are used in the production of plain socks have the breaking elongation of 25 to 35%. They are introduced into the knitting zone in the elongated state, but in the area of elastic recovery. After inserting the yarns into the knitted fabric and their removal from the needles, the yarns contract and achieve great contraction of the knitwear, which is desirable when putting on and using the sock. This kind of yarn participates in the sock from 8 to 30%. The third yarn used in the production of plain socks is elastane, usually monofilament, which is knitted into the sock cuff. It provides greater cuff compressibility on the leg and makes the sock stay up. The proportion of this yarn in the sock is from 2 to 10% [1,2].

Various plain socks which have special uses are developed using the same construction principles as classic plain socks. Therefore, socks for skiers, football, handball, basketball and tennis players are made according to predefined principles with some yarns that have special features being knitted into certain sock parts. In the case of the classic, or the so-called sports sock, elastane yarn is additionally knit into the body or one part of the foot, as necessary. Here, the proportion of elastane yarn is up to 30%. In the production of the ski sock, elastane yarn is partially knitted into certain rows while the polyamide yarn can be multiply or partially plated. Therapeutic socks used for medical purposes can be designed in two ways. One design has a compressive effect on healthy external leg tissue and is made almost exclusively from polyamide and elastane yarns. The latter sock design is put on a leg with active wounds. The wound is taken care of, protected by a bandage or swab, and a sock with mild compression is pulled over it. The leg is not dynamically active [3].

There is a continuous search for the most suitable yarns and yarn properties for all of the above mentioned and similar shapes of plain socks. The focus of this research is on the production of classic winter plain socks with viscose SIRO yarns and modal fibre yarns. [4,5].

2. Basic structures in sock production

Several types of plated knitted structures are used to make the classic unpatterned plain sock. The beginning of the sock is knitted in plain structure with a PA multifilament thread. After knitting ten rows of loops, base yarn is inserted along with it and the knitting is done in basic plated structure [6,7]. After base plating, another elastane yarn, but this time monofilament, is inserted after approximately ten rows to shape the cuff. Therefore,

the base sock cuff is manufactured using three significantly different yarns. After the cuff is made, the elastane thread is excluded and the knitting continues in base plated structure, i.e. this structure is used to knit the body, heel, foot and toes. In the manufacturing of a higher-quality sock, several yarns can be interlaced in one row, usually three or four, with differences in their fibre composition, structure and features, Figure. 1.

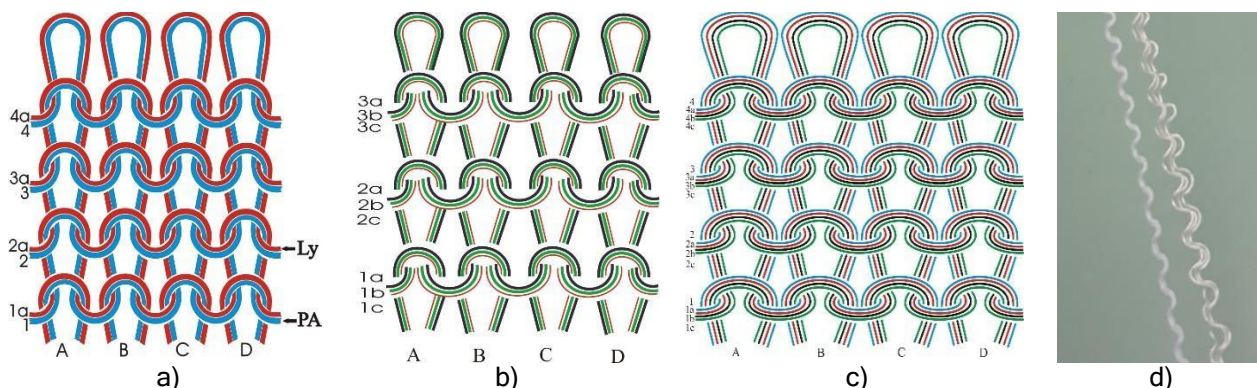

Figure 1: Plated jersey structures used in the manufacturing of plain socks; a) plain plated structure - two yarns in a row, b) multiple plated structure - three threads in a row, c) multiple plated structure - four yarns in a row, d) four separated yarns from a row; PA – cotton, Ly - elastane

3. Yarns and the machine for manufacturing the samples

Seven yarns with different fibre composition, yarn counts, structures and tensile properties were used to manufacture the socks [4,5]. The main parameters of tensile properties of the analysed yarns are given in Table 1 with $p=0.05$.

Table 1: Labels and tensile properties of yarns used in the sock production

Yarn	Breaking force, cN	Breaking elongation, %	Breaking load, cN/tex	Work to break, cN·cm
SP20	393 ± 7	13.6 ± 0.3	19.7 ± 0.4	1700 ± 59
MR20	487 ± 10	10.2 ± 0.2	24.3 ± 0.5	1436 ± 47
MOE20	326 ± 9	7.2 ± 0.2	16.3 ± 0.5	738 ± 32
MAJ20	406 ± 10	9.0 ± 0.2	20.3 ± 0.5	1067 ± 42
PA156	985 ± 5	30.3 ± 0.3	63.1 ± 0.3	8314 ± 133
PA220	991 ± 4	28.5 ± 0.2	45.1 ± 0.2	7846 ± 81
PKKR25	325 ± 13	6.1 ± 0.2	13.6 ± 0.6	506 ± 31

where: SP20 - viscose yarn with a yarn count of 20 tex spun by SIRO spinning process, MR20 - modal yarn with a yarn count of 20 tex spun by ring spinning process, MOE20 - modal yarn with a yarn count of 20 tex spun by rotor spinning process, MAJ20 - modal yarn with a yarn count of 20 tex spun by air-jet spinning process, PA156 - polyamide multifilament yarn with a yarn count of 156 dtex, PA220 - polyamide multifilament yarn with a yarn count of 220 dtex, PKKR25 - cotton yarn with a yarn count of 25 tex spun by ring spinning process.

The smallest yarn breaking force was 325 ± 13 cN and was recorded in cotton yarn spun by ring spinning process. The largest yarn breaking force was 991 ± 4 cN, recorded in PA multifilament yarn with a yarn count of 220 dtex. The smallest breaking elongation was 6.1 ± 0.2 %, recorded in cotton yarn with a yarn count of 25 tex, while the largest was 30.3 ± 0.3 %, recorded in PA multifilament yarn with a yarn count of 156 dtex. The smallest work to break was also recorded in cotton yarn, and the largest in PA multifilament yarn with a yarn count of 156 dtex. Based on the data obtained by measuring, it can be concluded that the analysed yarns differ significantly according to their tensile properties, and that cotton yarn has all the smallest recorded values of tensile properties. Sock samples were manufactured on a single-bed automatic hosiery machine with a cylinder diameter of 95 mm ($3 \frac{3}{4}$ inches) which used 108 needles and is used to manufacture winter plain socks. The machine uses the CAD/CAM system [8]. To manufacture the desired socks, a special computer control program was developed which controlled the knitting. The program contained all the important values for the manufacture of socks where four yarns are interlaced in a row. Loop sinking depth and knitting speed were defined for each sock row and section. The speed of feeding yarns from spools was adjusted to the knitting speed. The position of turning on/off the lead in/out of operation with certain yarns was also defined. According to the control program, the time to knit one sock was 178 ± 4 s.

4. Sock samples

Four main sample groups were manufactured with respect to fibre structure and yarn production process. In the first sock sample, the base yarn was viscose yarn made by SIRO spinning process (SP20). Three base and one polyamide yarn were inserted into one row. In the second sample, the base yarn consisted of modal fibres made by ring spinning process (MR20). The third group was also made from modal-fibre yarns, but by rotor spinning process (MOE20), while the fourth, also made from modal-fibre yarns, was made by air-jet spinning process (MAJ20). Each group had three subgroups. In the first subgroup, one row of loops was formed by three base yarns and one PA with a yarn count of 156 dtex. In the second group, PA yarn with a yarn count of 156 dtex was replaced by PA yarn with a yarn count of 220 dtex in order to obtain a fuller and less stretchable sock. In the third subgroup, one base yarn with a yarn count of 20 tex was replaced by cotton yarn with a yarn count of 25 tex, also to increase yarn fullness, and thereby also its thickness. All the socks were made using a single control program. The sock body, heel and foot were made in multiple plated structure and a single row was formed using four yarns. The socks were made for the leg with a foot length from 26 to 30 cm, which corresponds to the shoe size of 42 to 44 [9]. In total, 12 basic sock groups were manufactured.

5. Results of sock measurements

Considering the different structures and tensile properties of the yarns used, different measurements of certain major sock parts were expected, Tab. 2. The sock cuff width (B) is in the range between 83 and 86 mm or 84 ± 2 mm and can be considered uniform for practical use. The sock body width (B₁) is somewhat greater and is in the range between 85 and 91 mm or 88 ± 3 mm. The body width is greater than the cuff width because an elastane thread was not inserted into the body. The sock foot width is even greater and is in the range between 89 and 95 mm or 93 ± 3 mm.

Table 2: Measurements of the projected manufactured socks

Samples	Group A				
	B, mm	B ₁ , mm	B ₂ , mm	H, mm	H ₁ , mm
SIRO	83±1	85±1	89±1	237±2	269±5
MR	84±1	85±1	90±1	242±4	275±2
MOE	84±0	87±1	93±1	249±3	270±6
MAJ	85±1	89±1	92±1	255±3	280±5
Group B					
SIRO	84±1	88±1	91±0	229±2	272±2
MR	85±1	89±1	93±1	245±3	279±2
MOE	85±1	89±1	94±1	250±4	273±3
MAJ	85±0	90±1	94±1	251±2	275±7
Group C					
SIRO	85±0	89±1	91±1	241±1	270±5
MR	86±1	90±0	95±1	249±1	278±2
MOE	86±1	90±2	95±1	249±2	274±2
MAJ	86±1	91±1	94±2	250±3	277±3
AVERAGE	84±2	88±3	93±3	240±10	275±5

Sock height (H) is recommended, not defined, and depends on fashion trends or purpose. In the production of classic socks, it is recommended that the length be nearly the same as the foot length. In the samples it ranges between 229 and 255 mm or 240 ± 10 mm, while the foot length (H₁) ranges between 269 and 280 mm or 275 ± 5 mm. The size of a plain sock is determined according to the foot length with the allowed deviations of ± 10 mm [9]. According to the analysed measurements, all the manufactured and analysed socks can be classified into one size.

6. Results of the sock structure parameters

All the parameters of yarn structure are best reflected in the sock mass. The first group of samples had the average mass of 19.3 ± 0.1 , the second 21.5 ± 0.1 and the third 23.0 ± 0.1 g/pc, Tab. 3. The first group of socks was produced in a way that one row was made using three base yarns with a yarn count of 20 tex and one PA multifilament with a yarn count 156 dtex. The second group was also made from three base yarns, as

the first sample, but the PA multifilament yarn with a yarn count of 156 dtex was replaced with a coarser yarn with a yarn count of 220 dtex. The obtained sock mass was therefore greater. The third group has the greatest mass since one base thread with a yarn count of 20 tex is replaced by cotton yarn with a yarn count of 25 tex. As the sock mass increased with the change in yarn counts, yarn thickness in the socks also increased and was 1.24 ± 0.02 , 1.32 ± 0.03 and 1.41 ± 0.02 mm. Since the manufactured socks were winter plain socks, sock thickness is an important parameter in determining thermophysiological yarn features when evaluating sock comfort [10-12]. In such research, apart from sock thickness, data about fibre structure of yarn in a sock row is also important, Tab. 4. In the lightest socks, or the socks in Group A, the average share of the base yarn is $79 \pm 1\%$ and PA yarn $21 \pm 1\%$; in Group B, the average share of the base yarn is $71 \pm 1\%$ and PA yarn $29 \pm 1\%$. In the third sample group, the average share of the base yarn is $44 \pm 0\%$, PA yarn $28 \pm 1\%$ and cotton yarn $28 \pm 1\%$.

Table 3: Masses and thicknesses of the sock knit

Samples	Sock mass, g/pc			Sock thickness, mm		
	Group A	Group B	Group C	Group A	Group B	Group C
SIRO	19.0±0.0	21.1±0.0	22.7±0.0	1.18±0.01	1.26±0.02	1.38±0.02
MR	19.0±0.0	21.4±0.0	23.0±0.1	1.24±0.01	1.29±0.01	1.40±0.02
MOE	19.2±0.0	21.4±0.0	22.8±0.0	1.21±0.01	1.30±0.01	1.41±0.01
MAJ	19.4±0.1	21.7±0.1	23.0±0.1	1.25±0.01	1.36±0.02	1.44±0.02
AVERAGE	19.3±0.1	21.5±0.1	23.0±0.1	1.24±0.02	1.32±0.03	1.41±0.02

Table 4: Fibre composition in a row of the sock body

Yarn	A _u , %	B _u , %	C _u , %	Yarn	A _u , %	B _u , %	C _u , %	Yarn	C _u , %
SIRO	79	70	44	PA	21	30	28	PKKR	28
MR	78	71	44	PA	22	29	27	PKKR	29
MOE	78	71	44	PA	22	29	28	PKKR	28
MAJ	79	70	44	PA	21	30	28	PKKR	28
AVERAGE	79±1	71±1	44±0		21±1	29±1	28±1		28±1

where: A_u - share of the base yarn mass in a sock row, %, B_u - share of the PA multifilament yarn mass in a sock row, %, C_u - share of the cotton yarn mass in a sock row, %

7. Results of sock compression measurements

Compression of the sock body and cuff was measured in all the manufactured sock samples. Six wooden cylinders and the PicoPress device were used to measure compression, Fig. 2, [13,14]. The cylinders had the length of 200 mm and diameter/perimeter: 80/250, 90/283, 100/315, 110/345, 120/377 and 130/408 mm which mimicked the leg perimeter under the calf, i.e. place where the sock lies. The lowest compression of the sock body was measured on the smallest cylinder which had the measurements of 80/250 mm and it was 6.3 hPa. The highest compression was measured on the biggest cylinder, with the measurements of 130/408 mm and it was 23.9 hPa. The cuff compression was significantly higher and was in the range between 13.3 and 38.6 hPa.



Figure 2: Wooden cylinders with diameters of 80 do 130 mm and PicoPress device for measuring sock compression

Viscose yarn spun by SIRO spinning process was used to knit three groups of sock samples. The first group was made from the finest yarns, which resulted in the lightest sock. The third group was made from the

coarsest yarns, which resulted in the greatest sock mass. By stretching all three sock groups on a cylinder of the diameter/perimeter of 80/250 mm, the compression of 6.7 to 9.3 hPa was recorded, Fig. 3a. The greatest elongation was achieved on the 130/408 mm cylinder, while the recorded sock compression was from 18.6 to 23.9 hPa. Average compression results of all the sock samples and groups are somewhat smaller and range from 6.3 to 17.3 hPa, Fig. 3b. The recorded results of compression in the body of socks made from viscose SIRO yarns in Group B are 9.3 to 23.4 hPa, and the cuff 17.3 to 38.6 hPa, Fig. 4a.

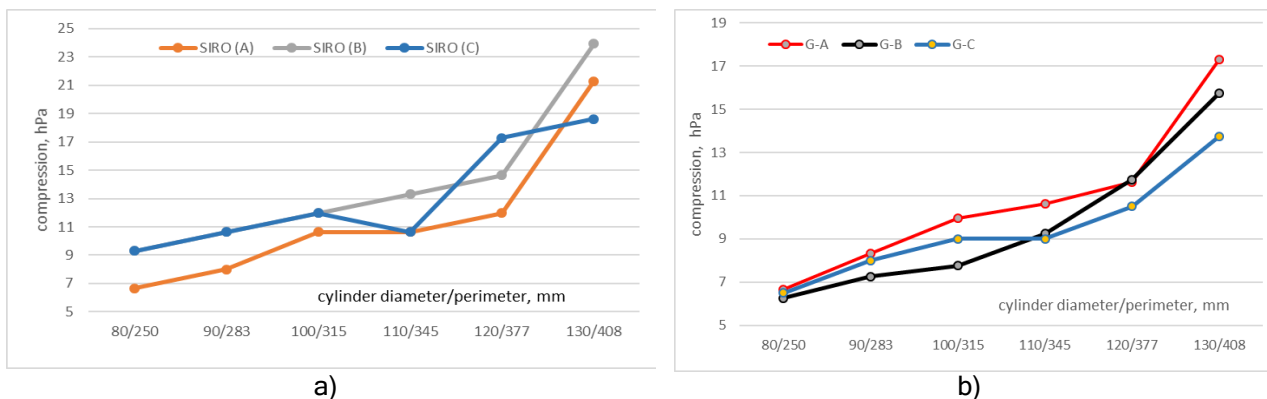

Figure 3: Recordings of the sock body compression on a wooden cylinder; a) socks made from viscose yarns by SIRO spinning process, b) average values of all the measured samples classified into three major groups

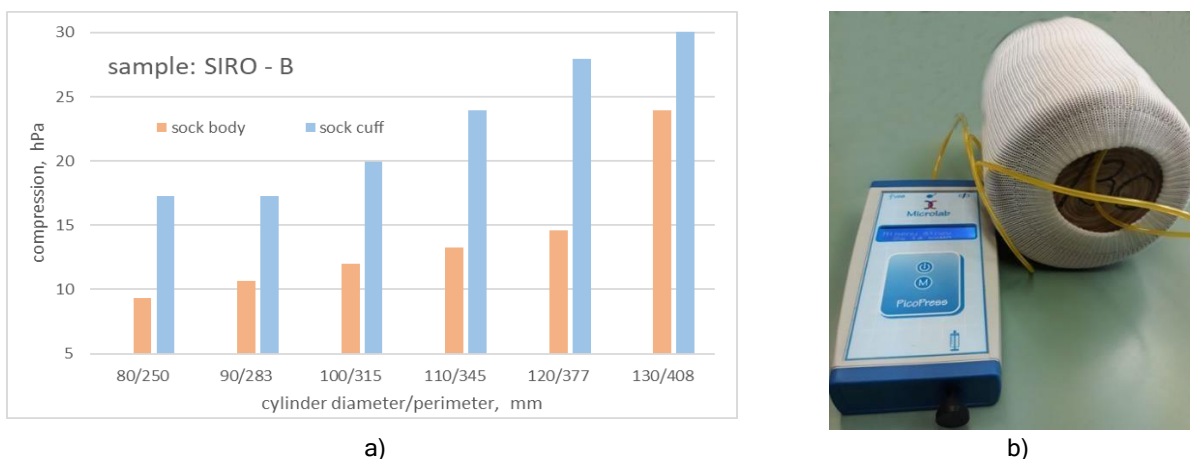

Figure 4: Recordings of the body and cuff compression of socks; a) made from viscose yarns by SIRO spinning process, Group B, b) recording compression of the sock body

8. Conclusion

Twelve groups of plain socks were designed, manufactured and analysed. They were produced from viscose and modal yarns made by different spinning processes. Based on the manufactured and analysed socks, the following can be concluded. Using different yarn combinations, three groups of socks with different masses were made in one size. The first group has the mass of 19.3 ± 0.1 g/pc, the second 21.5 ± 0.1 g/pc and the third 23.0 ± 0.1 g/pc. Compression of the sock body was measured on stiff cylinders with different diameters and it depends on the fibre structure and yarn structure, as well as inserting yarns into a row. The compression is from 6.3 hPa to 23.9 hPa. Elastane yarn was interlaced into the sock cuff. Therefore, the compression in the cuff is significantly higher than in the body or foot and ranges from 13.3 to 38.6 hPa. The socks were made for the leg with the foot length of 26 to 30 cm, or the shoe size of 42 to 44 and are recommended to be worn at temperatures between -10 and $+5$ °C. Due to the insertion of four high-quality yarns into a knit wale, the socks are considered quite a remarkable product. The main purpose of this paper is to explore the yarn usage from the newest fibres to make a quality classic winter short socks with four knitted yarns in one row.

Acknowledgment: This work was funded by the Croatian Science Foundation, Project IP-2016-06-5278.

References

- [1] Modig N.: Hosiery Machines, Meisenbach, Bamberg (1988)
- [2] Minčev V.: VGM1 - metod za ekspresno opredeljene na parametrite za pletene na čorapni izdelija, *XLIII Congress of the IFKT*, 01-05 October 2006, Plovdiv, Bulgaria (2006)
- [3] Vrljičak, Z. & Kovač, A.: Projektiranje i izrada kratkih čarapa, *Tekstil*, **60** (2011) 4, pp. 149-159, ISSN 0492-5882
- [4] Skenderi, Z. et al: Nejednolikosti aerodinamičke pređe u usporedbi s prstenastom i rotorskom predom od mikromodalnih vlakana, *Tekstil*, **67** (2018), 1-2, pp. 1-13, ISSN 0492-5882
- [5] Pavlović, Ž. et al.: Istraživanja strukture i vlačnih svojstava desno-desnih pletiva izrađenih predama različitog sirovinskog sastava i procesa pređenja pri jednakim parametrima pletenja, *Tekstil*, **66** (2017), 11-12, pp. 279-296, ISSN 0492-5882
- [6] Vrljičak Z. i Pavlović Ž.: Dimenzijska nestabilnost kratkih čarapa, *Tekstil*, **63** (2014), 1/2, pp. 27-40, ISSN 0492-5882
- [7] Vrljičak Z.: *Pletiva*, Sveučilište u Zagrebu Tekstilno-tehnološki fakultet, ISBN 978-953-7105-79-2, Zagreb (2019)
- [8] <http://www.lonati.com/it-machines-item.asp?idf=3>, *Accesed*: 2020-01-22
- [9] HRN F.G0.010.
- [10] Skenderi, Z. et al.: Termofiziološka udobnost nošenja obuće, *Koža & Obuća*, **66** (2017.), 3, pp. 12-21, ISSN 1849-9767
- [11] BS EN ISO 7730:2005 – Ergonomics of the thermal environment. Analytical determination and interpretation of thermal comfort using calculation of the PMV and PPD indices and local thermal comfort criteria
- [12] Čunko R.: *Ispitivanje tekstila*, Sveučilište u Zagrebu Tekstilno-tehnološki fakultet, ISBN 86-329-0180-X, Zagreb (2011)
- [13] <http://www.microlabitalia.it/case-history.php?azione=show&url=pico-press>, *Accesed*: 2020-01-22
- [14] <https://www.salzmann-group.ch>, *Accesed*: 2020-01-22

Authors:

mag.ing.techn.text. Tea JOVANOVIĆ (corresponding author)
University of Zagreb Faculty of Textile technology
Prilaz baruna Filipovića 28a, 10000 Zagreb, Croatia
Phone: +(385) (01) 3712 578

E-mail: tea.jovanovic@tff.hr

mag.ing.techn.text. Željka PAVLOVIĆ
University of Zagreb Faculty of Textile technology
Prilaz baruna Filipovića 28a, 10000 Zagreb, Croatia
Phone: +(385) (01) 3712 572

E-mail: zeljka.pavlovic@tff.unizg.hr

dipl. inž. Lozo MILOŠ
Hosiery factory 8.Mart d.o.o.
Senčanski put 85, 24000 Subotica, Serbia
Phone: +(381) (24) 55 34 11

E-mail: 8mart@eunet.rs

Prof. Zlatko VRLJIČAK Ph.D.
University of Zagreb Faculty of Textile technology
Prilaz baruna Filipovića 28a, 10000 Zagreb, Croatia
Phone: +(385) (01) 3712 578

E-mail: zlatko.vrljicak@tff.unizg.hr

ENVIRONMENTALLY ACCEPTABLE SYNTHESIS OF NANOPARTICLES FOR THEIR POTENTIAL USE AS TEXTILE COATINGS

Lela MARTINAGA; Sara ČAČKO; Stella HAMILTON;
Ana VRSALOVIĆ PRESEČKI & Iva REZIĆ

Abstract: Nanotechnology is a rapidly growing research area applicable in the textile industry, where nanoparticles integrated in the products can modify the existing materials or result with new product properties. Silver (Ag-) and gold nanoparticles (Au-NPs) are among the most commonly used NPs, and usually serve as coatings on medical textiles due to their antimicrobial properties. Therefore, there is an outgrowing need for the production of Ag- and Au-NPs, and it is necessary to develop a suitable and environmentally acceptable synthesis pathway. In this work, Ag- and Au-NPs syntheses were performed using glucose as a reductive agent. The influence of the different initial concentration of silver nitrate (AgNO_3), tetrachloroauric acid (HAuCl_4) and glucose was examined in a view of synthesizing the NPs of smallest size. The result has shown that the initial glucose concentration has a mild impact on both NPs synthesis while the influence of initial AgNO_3 and HAuCl_4 concentration was higher. Smallest Ag-NPs were synthesized using lowest glucose and highest AgNO_3 concentration while the smallest Au-NPs were observed when both glucose and HAuCl_4 were at the lowest or highest tested level.

Keywords: nanoparticles, glucose, environmentally acceptable synthesis, reaction optimization

1. Introduction

Nanotechnology is a rapidly growing research area applicable in science and technology by creating new functional materials, devices and systems by using particles at the nanometer scale (1-100 nm) and exploiting new phenomena and properties that occur along these dimensions. Therefore, by synthesizing nanoparticles (NPs) of a specific size, it is possible to directly affect their properties and application behavior. [1] Various types of NPs are nowadays used in optoelectronic devices, biochemical sensors, water purification and catalysts, and their application in chemotherapy, medicine, and packaging, food and textile industries is increasing daily [2].

Gold nanoparticles (Au-NPs) are one of the most stable types of metal NPs. They are biocompatible and low toxic as well as specific in terms of their electronic, magnetic, and optical properties [3]. They are often used as colorimetric sensors, in medicine i.e. as biomarkers to mark certain cell types in the diagnosis of heart disease or cancer, or in the hypothermic cancer treatment [1, 4]. In textile industry, Au-NPs are usually used for developing the multifunctional textiles. Tang et al. have functionalized cotton fabric by Au-NPs synthesized *in situ* which resulted with its colorfastness to washing and rubbing, catalytic activity, improved ultraviolet (UV)-blocking ability, and remarkable antibacterial activity [5]. Johnston et al. have proved the same in the case of coating wool and cotton fabric with Au-NPs of different sizes and hence colors, which can be used in high quality fabrics and textiles for high end fashions [6]. Silver nanoparticles (Ag-NPs) are the most widely used metal NPs. Due to their unique bactericidal, optical, catalytic and other properties, Ag-NPs are mainly used in medicine, production of the personal use items, children's toys, catalysts, sensors, photovoltaic devices, etc. [1] Since textile products can serve as a medium for bacteria and fungi growth, and microbes transportation, numerous strategies for their antimicrobial finishing have been studied. In example, Ballottin et al. reported strong antimicrobial activity of cotton fibers impregnated with Ag-NPs against *Candida* sp., while Zhang et al. reported an excellent antibacterial properties of silk fabrics finished with Ag-NPs against *Staphylococcus aureus* and *Escherichia coli*, both with excellent laundering durability [7, 8]. Therefore, the ability of Ag-NPs impregnated textiles to reduce the microbial growth or eliminate microorganisms allows a great applicability of those products in wound dressings, medical staff uniforms, bedsheet and others [7]. Plenty of other research groups studied primarily antimicrobial activity, but also the possible role of Ag- and Au-NPs as a colorant or antistatic agent of functionalized cotton, wool, silk, polyester, polyamide, and polypropylene fibers as some of the fibers most widely used for daily use products [9-11].

Since the impact of the nanotechnology and NPs on the human health and environment has not yet been fully investigated, it is important to eliminate aggressive processes and toxic chemicals in the NPs synthesis, and to develop ecologically and economically acceptable as well as easily accessible methods [12]. So far, metal NPs have been successfully synthesized using various bioreductants such as agro-waste, plants, plant

extracts, enzymes, and carbohydrates. Engelbrekt et al. reported successful Au-NPs synthesis using glucose as a reducing and starch as a capping agent, Pettegrew et al. successful Ag-NPs synthesis using monosaccharide sugar including ribose, fructose, sorbose, glucose, xylose, and galactose, while Henry et al. reported successful Au- and Ag-NPs synthesis using glucose both as reducing and stabilizing agent using four different methods [12-14]. In this paper, the influence of the reaction conditions on the synthesis of the smallest Au- and Ag-NPs using glucose as a reductive agent as an ecologically acceptable method was investigated.

2. Experimental

Synthesis of Au- and Ag-NPs was conducted in 2 mL polystyrene batch reactors using tetrachloroauric(III) acid (HAuCl₄) and silver nitrate (AgNO₃) as a metal salt precursor, starch as a stabilizing and glucose as a reducing agent. The synthesis was carried out in 0.1 M phosphate buffer with pH 7 and 5 for the Au- and Ag-NPs synthesis, respectively. The influence of the reaction conditions, i.e. the initial concentration of metal salt precursors and glucose, was investigated by conducting 12 experiments for each type of NPs (Table 1).

Table 1: List of the conducted experiments

Experiment		$c(\text{HAuCl}_4) / c(\text{AgNO}_3)$ [mM]	$c(\text{glucose})$ [mM]	$\gamma(\text{starch})$ [mg mL ⁻¹]
1. SET	EXP.1-1	0.1 / 0.1	10	1
	EXP.1-2	0.3 / 0.25	10	1
	EXP.1-3	0.6 / 0.43	10	1
	EXP.1-4	1 / 1	10	1
2. SET	EXP.2-1	0.1 / 0.1	7	1
	EXP.2-2	0.3 / 0.25	7	1
	EXP.2-3	0.6 / 0.43	7	1
	EXP.2-4	1 / 1	7	1
3. SET	EXP.3-1	0.1 / 0.1	5	1
	EXP.3-2	0.3 / 0.25	5	1
	EXP.3-3	0.6 / 0.43	5	1
	EXP.3-4	1 / 1	5	1

Experiments were carried out in the presence of light and oxygen at room temperature. During the reactions pH value, absorption spectra, glucose, and starch concentrations were monitored using pH meter (*pH-meter Lab 850*, SI Analytics GmbH, Germany) and spectrophotometer (*Shimadzu UV-1800*, Shimadzu, Japan), respectively. The absorption spectra were measured in the wavelength region from 300 and 450 nm to 700 nm. Glucose and starch concentration was determined using glucose oxidase-phenol aminophenazone (GOD-PAP) and iodine test, respectively.

The hydrodynamic diameter of the synthesized NPs was determined using the nanoparticle tracking analysis method (NTA) using Malvern Nanosight LM10 (MalvernPanalytical, United Kingdom). This method is based on tracking single particles in liquid suspension illuminated by a specially shaped laser beam. Particles in the path of the beam, depending on their size, scatter the laser light which is then collected by the microscope objective and viewed with a digital camera that captures a video of the particles moving under Brownian motion in real-time. Using the Stoke-Einstein equation, NTA software calculates the hydrodynamic diameter of particles [15].

3. Results and Discussion

3.1 Gold nanoparticles synthesis

Synthesis of the Au-NPs (Figure 1) in 12 performed experiments (Table 1) was confirmed by the absorption spectra, i.e. the formation and increase of the absorption peak maximum in the wavelength range between 500 and 550 nm which corresponds to the Au-NPs (Figure 2a) [16, 17]. From the absorption spectra, the absorption maximums at a given time for a particular experiment were determined. The result was shown as the dependence of the absorption maximums on reaction time for the first set of experiments (Figure 2b) and, as in the other two sets, almost linear increase of the maximum absorbance of the synthesized Au-NPs during the reaction was observed. The dependence of the highest maximum absorbance achieved during a single experiment of the set on the initial HAuCl₄ concentration is shown in Figure 2c. As expected, those results refer that higher initial HAuCl₄ concentration results with higher maximum absorbance values, and therefore, more Au-NPs were synthesized. The increment was observed as linear up to 0.6 mM.

Glucose concentration in each individual experiment was monitored spectrophotometrically, and the results for the first set of experiments are shown in Figure 3a. A slight increase in the glucose concentration during the reaction was observed. This can be explained by the evaporation of the reaction solution, i.e. it's concentrating and, to ensure the reproducibility of the research, it would be preferable to work in an isolated reaction system to avoid the evaporation. Figure 3b shows the dependence of the maximum absorbance on the initial glucose concentration at different Au ions concentration and the results implied that glucose has slight impact on the synthesis of Au-NPs if the initial concentration of Au ions is up to 0.6 mM. At higher Au ions concentration, it doesn't have any influence. Starch concentration and pH value was not significantly changed during the reaction (data not shown).

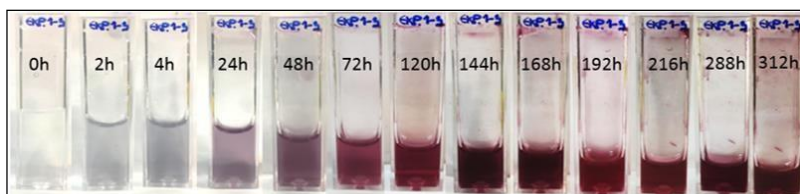

Figure 1: Reaction solution during Au-NPs synthesis (experiment 1-3: $c(\text{HAuCl}_4)=0.6 \text{ mM}$, $c(\text{glucose})=10 \text{ mM}$, $\gamma(\text{starch}) = 1 \text{ mg mL}^{-1}$)

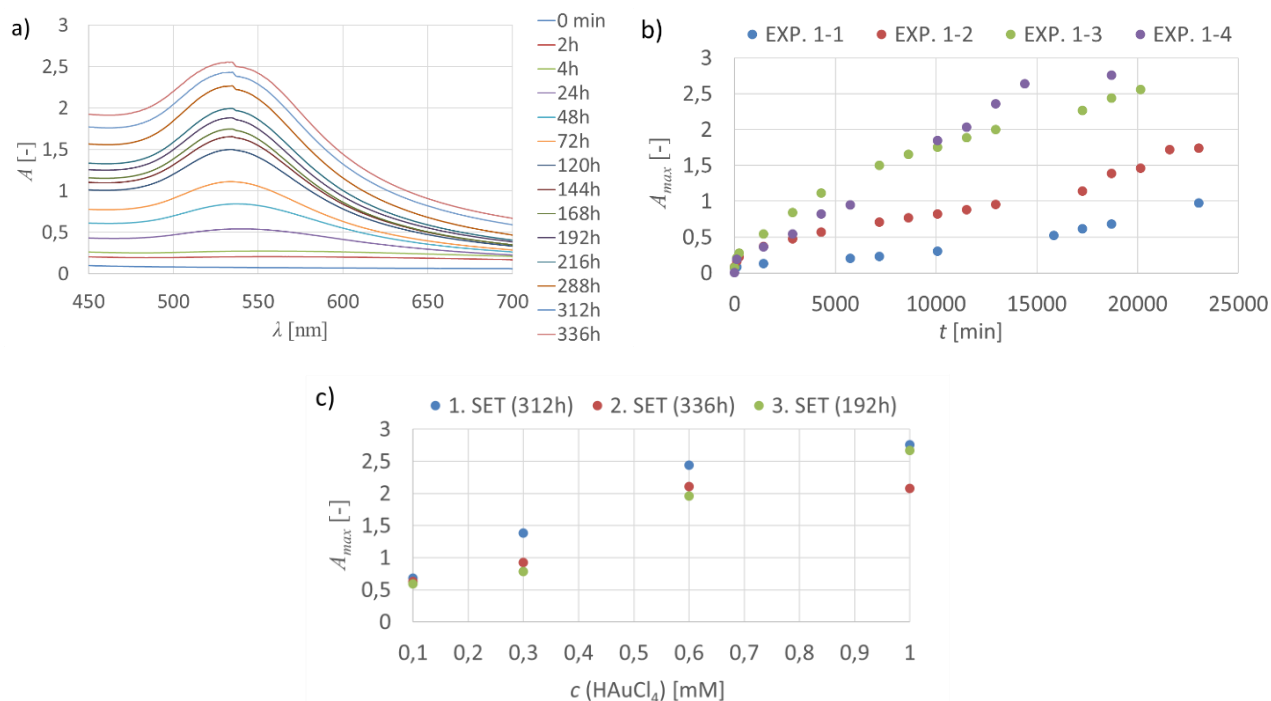

Figure 2a: Absorption spectra during Au-NPs synthesis (experiment 1-3; $c(\text{HAuCl}_4)=0.6 \text{ mM}$, $c(\text{glucose})=10 \text{ mM}$, $\gamma(\text{starch})=1 \text{ mg mL}^{-1}$); **b:** increment of the maximum absorbance during time within first set of experiments; **c:** increment of the maximum absorbance depending on the initial HAuCl_4 concentration

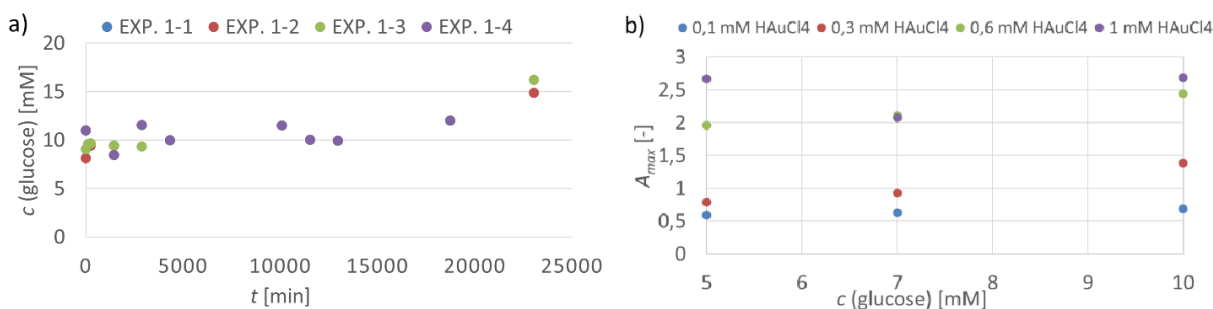

Figure 3a: Glucose concentration during Au-NPs synthesis within first set of experiments; **b:** dependence of the maximum absorbance of each experiment on the initial glucose concentration

3.2 Silver nanoparticles synthesis

The synthesis of Ag-NPs (Figure 4) was monitored spectrophotometrically and the presence of the NPs was confirmed in most of the experiments conducted by formation and increase of the absorption peak maximum in the wavelength range between 400 and 450 nm which corresponds to the Ag-NPs (Figure 5a). [18] Formation of the Ag-NPs was not successful within first experiments of each set (Table 1) in which AgNO_3 was the lowest (0.1 mM). From the absorption spectra of the successfully conducted experiments, the absorption maximums at a given reaction time were determined. The results for the third set of experiments are shown in Figure 5b. As in the case of Au-NPs synthesis, almost linear increase of the maximum absorbance during Ag-NPs synthesis was observed. The dependence of maximum absorbance achieved in a single experiment within the set to the initial AgNO_3 concentration is shown in Figure 5c. As it was the case with Au-NPs, the results herein also indicated that higher initial AgNO_3 concentration resulted with a higher maximum absorbance values, i.e. more Ag-NPs was synthesized.

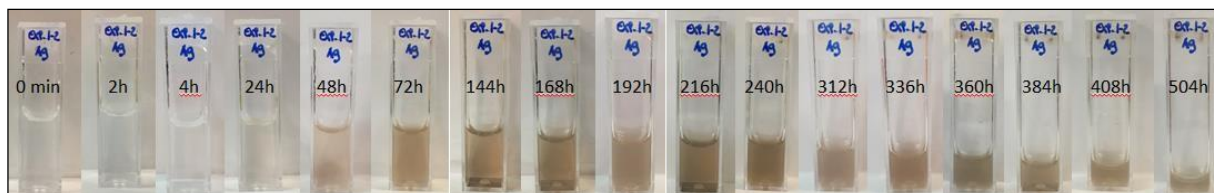

Figure 4: Reaction solution during Ag-NPs synthesis (experiment 1-2: $c(\text{AgNO}_3)=0.25$ mM, $c(\text{glucose})=10$ mM, $\gamma(\text{starch})=1$ mg mL⁻¹)

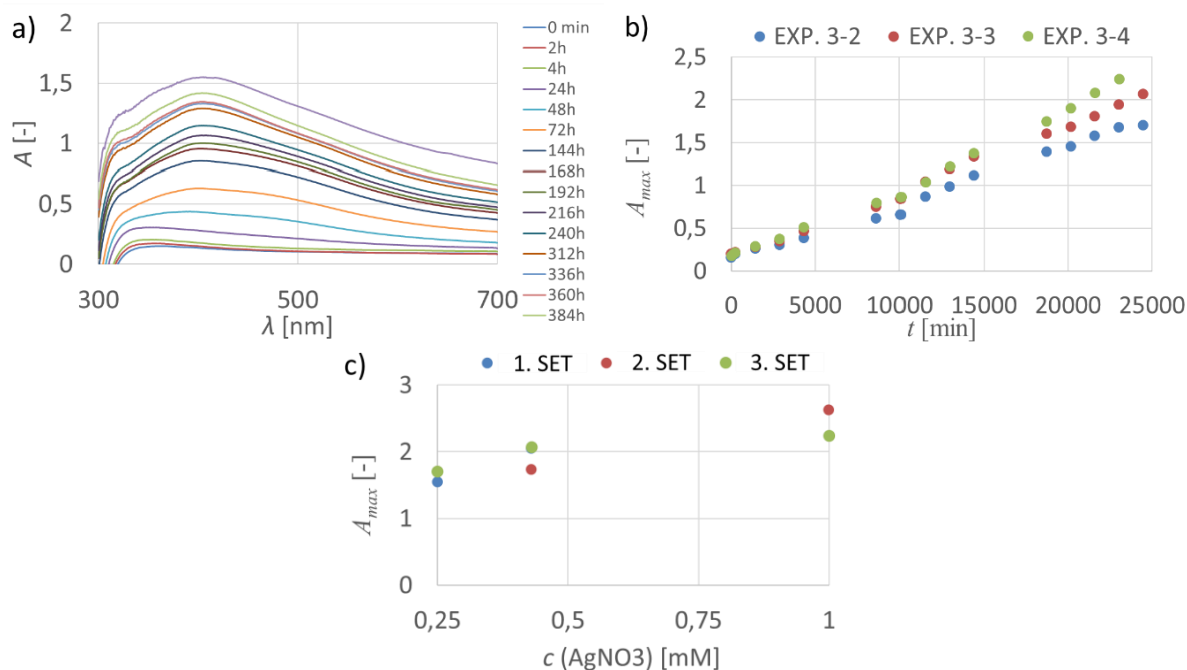

Figure 5a: Absorption spectra during Ag-NPs synthesis (experiment 1-2; $c(\text{AgNO}_3)=0.25$ mM, $c(\text{glucose})=10$ mM, $\gamma(\text{starch})=1$ mg mL⁻¹); **b:** increment of the maximum absorbance during time within third set of experiments; **c:** increment of the maximum absorbance depending on the initial AgNO_3 concentration

Glucose concentration in each individual experiment was monitored spectrophotometrically, and the results for the third set of experiments are shown in Figure 6a. As well as during Au-NPs synthesis, slight increase in the glucose concentration during the reaction was observed which was due to the evaporation of the reaction solution, i.e. it's concentrating. Figure 6b shows the dependence of the maximum absorbance of each experiment on the initial glucose concentration. According to those results, there is a mild influence of the initial glucose concentration on the Ag-NPs synthesis, and the best result was achieved when mid tested glucose concentration (7 mM) was combined with the highest tested AgNO_3 concentration (1 mM). The starch concentration and pH values were not significantly changed during the reaction (data not shown).

3.3 Characterization of the synthesized nanoparticles

The hydrodynamic diameter of the NPs synthesized within those experiments was determined by NTA method using Malvern Nanosight LM10. Results are shown in Table 2 and are implying that lower initial concentration of HAuCl₄ favors the synthesis of smaller Au-NPs whereas the influence of the initial glucose concentration on the hydrodynamic diameter of the Au-NPs is negligible. It can be concluded that the smallest Au-NPs were formed when higher glucose concentration was combined with higher HAuCl₄ concentration and vice versa. The hydrodynamic diameter of the synthesized Ag-NPs is not influenced by the initial glucose concentration as well. Smaller Ag-NPs were formed using higher initial AgNO₃ concentration combined with lower glucose concentration. Generally, the synthesis of the smaller Ag-NPs was achieved by the higher AgNO₃ and lower glucose concentration.

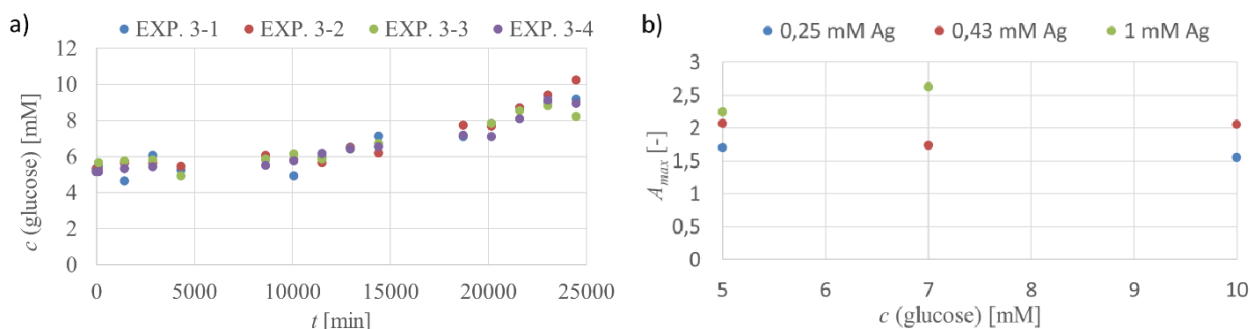

Figure 6a: Glucose concentration during Ag-NPs synthesis within third set of experiments; **b:** dependence of the maximum absorbance of each experiment on the initial glucose concentration

Table 2: Results of the NTA analysis of the Au- and Ag-NPs

Experiment		Hydrodynamic diameter [nm]		Experiment		Hydrodynamic diameter [nm]		Experiment		Hydrodynamic diameter [nm]	
		Au-NPs	Ag-NPs			Au-NPs	Ag-NPs			Au-NPs	Ag-NPs
1. SET	EXP.1-1	216.2	165.85	2. SET	EXP.2-1	184.7	225.15	3. SET	EXP.3-1	198.6	196.95
	EXP.1-2	191.7	187.4		EXP.2-2	202.6	189.05		EXP.3-2	183.9	187.2
	EXP.1-3	193.4	193.45		EXP.2-3	199.8	160.5		EXP.3-3	218.3	171.5
	EXP.1-4	207.3	174.8		EXP.2-4	183.9	154.4		EXP.3-4	212.9	102.7

4. Conclusion

This research resulted with successfully synthesized biocompatible Au- and Ag-NPs for their potential application as antimicrobial agent in textile industry. The syntheses were performed using glucose as environmentally acceptable reductive agent in the presence of light and oxygen at room temperature in a phosphate buffer thereby making this process economically acceptable. The aim of the study was to investigate the influence of the initial concentration of reducing agent and metal precursor on the hydrodynamic diameter of the synthesized NPs. The results showed that the hydrodynamic diameter of the synthesized Au-NPs was almost independent on initial glucose or HAuCl₄ concentration, but slightly smaller Au-NPs were synthesized when higher glucose concentration were combined with higher initial HAuCl₄ concentration and when lower glucose concentration was combined with lower initial HAuCl₄ concentration. As well, the hydrodynamic diameter of the synthesized Ag-NPs does not significantly depend on the initial glucose concentration, but it was observed that smaller Ag-NPs were synthesized using higher concentrations of AgNO₃ especially in reaction carried out by lower initial glucose concentrations. According to the obtained maximum absorbance, it was observed that more Au- and Ag-NPs were synthesized using higher metal precursor concentration as well as that less reaction time was needed to obtain those maximums with higher metal precursor concentration used.

Acknowledgment: The authors thank Marija Brgles, PhD from Center for Research and Knowledge Transfer in Biotechnology, University of Zagreb for usage of Malvern Nanosight LM10. This work was financially fully supported by the Croatian Science Foundation, Young researchers' career development project – Training of new doctoral students, and research project IP-2019-04-1381 under title „Antibacterial coating for

biodegradable medicine materials ABBAMEDICA“. Any opinions, findings and conclusions or recommendations expressed in this material are those of the authors and do not necessarily reflect the views of Croatian Science Foundation.

References

- [1] Kurajica, S.; Lučić Blagojević, S.: Uvod, Metalne i keramičke nanočestice i nanostrukturirani materijali, In *Uvod u nanotehnologiju*, Hrvatsko društvo kemijskih inženjera i tehnologa, ISBN 978-953-6894-59-8, Zagreb (2017), pp. 2-10, 242-245
- [2] Dwivedi, A.D.; Ma, L.Q.: Biocatalytic synthesis pathways, transformation, and toxicity of nanoparticles in the environment, *Critical Reviews in Environmental Science and Technology*, **44** (2014) 15, pp. 1679-1739, ISSN 1064-3389
- [3] Daniel, M.C.; Astruc, D.: Gold nanoparticles: assembly, supramolecular chemistry, quantum-size-related properties, and applications toward biology, catalysis, and nanotechnology, *Chemical Reviews*, **104** (2004) 1, pp. 293-346, ISSN 1520-6890
- [4] <https://www.sigmaaldrich.com/technical-documents/articles/materials-science/nanomaterials/gold-nanoparticles.html> (Accessed: 2019-08-04)
- [5] Tang, B. et al.: In situ synthesis of gold nanoparticles on cotton fabric for multifunctional applications, *Cellulose*, **24** (2017) 10, pp. 4547-4560, ISSN 0969-0239
- [6] Johnston, J. H.: Gold nanoparticles as colourants in high fashion fabrics and textiles, *TechConnect Briefs*, **1** (2008), pp. 712-715, ISBN 978-1-4200-8503-7
- [7] Ballottin, D. et al.: Antimicrobial textiles: Biogenic silver nanoparticles against *Candida* and *Xanthomonas*, *Materials Science and Engineering C*, **75** (2017), pp. 582-589, ISSN 0928-4931
- [8] Zhang, G. et al.: Synthesis of silver nanoparticles and antibacterial property of silk fabrics treated by silver nanoparticles, *Nanoscale Research Letters*, **9** (2014), Art. Nr. 216, ISSN 1556-276X
- [9] Radetić, M.: Functionalization of textile materials with silver nanoparticles, *Journal of Materials Science*, **48** (2013) 1, pp. 95-107, ISSN 1573-4803
- [10] Zhang, Z. et al.: Complex coloration and antibacterial functionalization of silk fabrics based on noble metal nanoparticles, *Journal of Engineered Fibers and Fabrics*, **14** (2019), pp.1-8, ISSN 1558-9250
- [11] Elmaaty, T. A. et al.: One-step green approach for functional printing and finishing of textiles using silver and gold NPs, *RSC Advances*, **8** (2018) 45, pp. 25546-25557, ISSN 2046-2069
- [12] Engelbrekt, C. et al.: Green synthesis of gold nanoparticles with starch-glucose and application in bioelectrochemistry, *Journal of Materials Chemistry*, **19** (2009) 42, pp. 7839-7847, ISSN 1364-5501
- [13] Pettegrew, C. et al.: Silver nanoparticle synthesis using monosaccharides and their growth inhibitory activity against gram-negative and positive bacteria, *ISRN Nanotechnology*, **2014** (2014), Art. Nr. 480284, ISSN 2090-6064
- [14] More et al.: 'Green' synthesis of stable silver and gold nanoparticles using soluble glucose, *Proceedings of International conference on nanoscience, engineering & advanced computing*, Prades, A. (Ed.), pp. 1-4, ISBN 978-81-8465-683-1, Narsapur, India, July 2011, W.G.DIST
- [15] <https://www.malvernpanalytical.com/en/products/technology/nanoparticle-tracking-analysis> (Accessed: 2020-03-10)
- [16] Zuber, A. et al.: Detection of gold nanoparticles with different sizes using absorption and fluorescence based method, *Sensors and Actuators B – Chemical*, **227** (2016), pp. 117-127, ISSN 0925-4005
- [17] He, Y.Q. et al.: A study on the sizes and concentrations of gold nanoparticles by spectra absorption, resonance Rayleigh scattering and resonance non-linear scattering, *Spectrochimica Acta Part A – Molecular and Biomolecular Spectroscopy*, **61** (2005) 13-14, pp. 2861-2866, ISSN 1386-1425
- [18] <https://www.sigmaaldrich.com/technical-documents/articles/materials-science/nanomaterials/silver-nanoparticles.html> (Accessed: 2020-03-11)

Authors:

mag. ing. oecoing. Lela MARTINAGA (corresponding author); Assoc. Prof. Iva REZIĆ, PhD PhD
University of Zagreb Faculty of Textile Technology
Prilaz baruna Filipovića 28a, 10 000 Zagreb, Croatia
Phone: +385 1 3712 590; +385 1 371 593 E-mail: lela.pintaric@ttf.unizg.hr; iva.rezic@ttf.unizg.hr

univ. bacc. ing. oecoing. Sara ČAČKO; univ. bacc. ing. oecoing. Stella HAMILTON; Prof. Ana VRSALOVIĆ PRESEČKI, PhD
University of Zagreb Faculty of Chemical Engineering and Technology
Marulićev trg 19, 10 000 Zagreb, Croatia
Phone: +385 1 4597 157 E-mail: stella.hamilton1@gmail.com; saracacko995@gmail.com; avrsalov@fkit.hr

NANOBIOCOMPOSITES REINFORCED WITH SPANISH BROOM (*Spartium Junceum* L.) FIBRES

Zorana KOVAČEVIĆ, Sandra BISCHOF, Mizi FAN

Abstract: *Tensile strength of natural fibres used as reinforcement in biocomposite material and treated with microwaves show approximately 60 % higher strength compared to conventional treated fibres and 30 % compared to novel osmotic degumming method. Functionalization of fibres was carried out using montmorillonite (MMT) nanoclay particles and citric acid (CA) as an environmentally friendly crosslinker. Effectiveness of the conducted modifications was examined according to the relevant standardized methods used in current industrial and manufacturing processes (testing of morphological, mechanical, chemical and thermal properties of the final composite material). MMT/CA modified fibres show better thermal stability in comparison to the reference fibre (MWR) which is proved by thermogravimetric analysis. Fibre/polymer interface was also positively influenced by MMT/CA fibre modification. Biodegradability of developed composite materials was examined with serine endopeptidase. Concentration of 50 wt.% enzyme reveals very positive result of composite degradation. Additionally, the possibility of residue stem utilization in bioenergy production was investigated. Proximate and ultimate analysis of residues after MW maceration showed increase in content of positive biomass quality indicators.*

Keywords: *Spartium junceum L., PLA, sustainability, green composites, nanoparticles, flame retardant, biodegradation, bioenergy, solid biofuel.*

1. Introduction

Increased demand for usage of sustainable and biodegradable natural materials initiated wider production of biocomposites. For that reason, composite materials made of sustainable polylactide (PLA) polymer and *Spartium junceum* L. (SJL) bast fibres were designed and produced in the course of research for this thesis. Three fibre extraction (maceration) methods were investigated: water retting (WR), osmotic degumming (OD) and alkali retting under the influence of microwave energy (MW). It was proven that long lasting conventional maceration method can be successfully replaced by ecologically favourable method using microwaves. Natural fibre reinforcements are capable to enhance composite overall properties like mechanical and flame-retardant properties. Alkaline, coupling agents and nanoparticle treatments were used to overcome drawbacks that natural fibres show while used in biocomposite material. Clay nanoparticles were added as a nanofiller which affects the improvement of both mechanical and thermal properties of biocomposites. The increasing use of biocomposites in the normal human life provides a better and healthier life, as well as more holistic view to restoration of eco-system. SJL biomass remaining after fibre extraction was confirmed as promising feedstock for solid biofuel production. The significance of the proposed research lies in the application of innovative, sustainable raw materials for the production of new advanced products of wide application.

2. Materials and methods

2.1 Materials

SJL fibres were obtained from SJL plant, harvested from the area around town Šibenik, Croatia. PLA Ingeo 6201D was purchased from Nature Works LLC, USA with following physical properties: specific gravity is 1.24, relative viscosity is 3.1, melt index is 15-30 g/10 min and melt density is 1.08 g/cm³. NaOH pellets (purity ≥ 97 %), nanoclay modified with 25-30 wt.% octadecylamine, citric acid, sodium hypophosphite hydrate (NaH₂PO₂) use for this study were obtained from Sigma-Aldrich Inc., UK. The Fluka buffer solutions were used for setting of pH 9.0 (borax/hydrochloric acid). Enzyme Savinase 16 L was obtained from Strem Chemicals, Inc. It is in liquid form with optimum conditions being 30 - 70 °C, pH 8 - 10 and activity of 16 Kilo Novo Protease Unit KNPU (S/g).

2.2 Methods

Numerous methods and testing devices were used in this research [1]. 3 different methods for fibre extraction (WR, OD, MW), chemical modification of fibres, composite manufacturing process, chemical composition of fibres, fibre's moisture regain and moisture content, fibre density determination, tensile properties of fibres and

composites, micromechanical modelling of composites, morphological characterization of sample surfaces by Scanning electron microscopy (SEM), fibre's surface chemistry and its crystallinity indexes by Fourier transform infrared spectroscopy (FTIR), surface properties of fibres by zeta potential determination, thermal degradation of fibres and composites and their kinetic parameters by thermogravimetric analysis (TGA), thermal transition temperatures of composites and the degree of polymer crystallinity of the samples by Differential scanning calorimetry (DSC), the heat of combustion of the gases evolved during controlled heating of composites by Microscale combustion calorimetry (MCC), enzymatic degradation of composites by weight loss measurement, biofuel quality parameters by determination of moisture, ash, coke, volatile matter, fixed carbon, oxygen, carbon, hydrogen, nitrogen and sulphur content, as well as determination of biofuel heating values by using an oxygen bomb calorimeter.

2.3 Samples

Table 1 presents sample description.

Table 1: Sample description

Fibre maceration	Fibre modification	Composites	Composites after biodegradation	Residues after fibre extraction
WR - water retting	MWR - reference fibre	PLA - neat polymer	PLA/CR/C1/C2/C3 20%E - material treated with 20 wt.% enzyme	0 _R - SJL stem before fibre extraction
OD - osmotic degumming	1F - fibre modified with NaOH	CR - composite material made of PLA and MWR fibres	PLA/CR/C1/C2/C3 50%E - material treated with 50 wt.% enzyme	SW _R - SJL residue after fibre extraction in salty water
MW - alkali retting under microwave energy	2F - fibre modified with MMT nanoclay and NaOH	C1 - composite material made of PLA and 1F fibres	PLA/CR/C1/C2/C3 100%E - material treated with 100 wt.% enzyme	MW _R - SJL residue after MW fibre extraction
	3F - fibre modified with MMT nanoclay and citric acid CA	C2 - composite material made of PLA and 2F fibres		
		C3 - composite material made of PLA and 3F fibres		

3. Results and discussion

Results are presented in five (5) different chapters.

3.1 Fibre quality

Crucial fibre quality criterion are strength, fineness, length and length uniformity, method of fibre extraction, moisture content, color grade, climate factors throughout the season and soil quality [2]. In this research three methods for natural bast fibre extraction were examined: biological/mechanical (WR with mechanical decortication), physical/mechanical (OD with mechanical decortication) and physical/chemical (MW) method.

Table 2: Prime quality parameters of SJL fibres extracted by various treatments. Results are presented as mean value within 95 % confidence interval

Fibres	Breaking tenacity (cN/tex)	Fineness (dtex)	Elongation (%)
WR	40.66 ± 1.85	41.17 ± 1.74	3.48 ± 0.14
OD	46.21 ± 1.94	40.97 ± 1.46	5.01 ± 0.19
MW	64.44 ± 1.80	36.75 ± 1.81	6.03 ± 0.18

In Table 2 it can be seen that MW extracted SJL fibres show increase in fineness comparing to other two types of fibre treatment (WR and OD) which leads to less stiffness. MW extracted SJL fibres show the highest elongation at break (6.03 %) and breaking tenacity (64.44 cN/tex) values implying the increased toughness of the SJL fibres obtained by MW treatment. The moisture regain of SJL fibres obtained from various treatments

was investigated under 65 % of relative humidity at 22°C and it ranges between 7 and 8 % as presented in Figure 1. Fibres processed under MW treatment have higher moisture regain, which is due to the more successful pectin, lignin and wax removal [3].

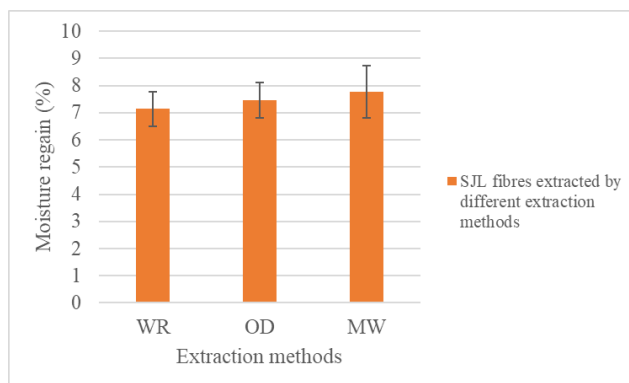

Figure 1: Moisture regain of *Spartium junceum* L. fibres extracted by different methods where WR is water retting extraction method; OD is osmotic degumming method and MW is alkali retting under microwave energy

FTIR spectra of SJL fibres treated by different extraction methods show that in sample MW lipophilic components are successfully removed and its secondary cell wall is more developed which influence higher mechanical strength of such fibres [4].

3.2 Fibre functionalization

Since MW fibres has showed better properties regarding WR and OD fibres they were further modified by alkali, coupling agent and nanoparticle treatments in order to meet demands for materials used in attractive industries like automotive and construction industry [5]. Structural, physico-chemical, thermal and mechanical properties of MW fibres were investigated but in this conference paper only thermal and mechanical results are presented.

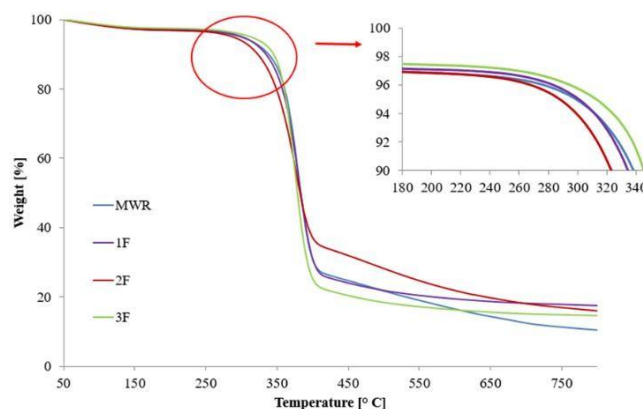

Figure 2: TGA analysis of SJL fibres

In Figure 2 is noticeable that sample 3F shows higher thermal stability than others and higher residue content at 800 °C which is due to more inorganic content inside the modified fibres.

Table 3 shows that fibre strength is increased by nanoclay modification due to the MMT nanolayered structure. Young modulus of modified fibres is slightly higher than modulus of MWR. Lower modulus indicates softer fibres with higher cohesion forces. MMT modified fibres show increase in elongation at break as well [6] which indicates strong and tough fibre that can be used for wide-range industrial purposes.

Table 3: Fibre strength and Young modulus of SJL fibres. Results are presented as mean value within 95 % confidence interval

Sample	Fibre Density g/cm ³	Fibre Strength		Young Modulus	
		cN/tex	MPa	cN/dtex	GPa
MWR	1.55 ± 0.0026	64.44 ± 1.80	998.85 ± 27.97	114.45 ± 4.22	17.87 ± 0.66
1F	1.55 ± 0.0019	60.00 ± 1.33	930.04 ± 20.62	118.71 ± 4.19	18.53 ± 0.65
2F	1.55 ± 0.0027	68.84 ± 1.54	1067.04 ± 23.85	116.65 ± 4.30	18.21 ± 0.67
3F	1.55 ± 0.0028	67.40 ± 1.42	1044.67 ± 22.00	114.82 ± 3.95	17.93 ± 0.61

3.3 Biocomposites – mechanical and thermal properties

Manufactured composite material is based on PLA biodegradable matrix and natural SJL fibres. One of the most important parameters that influence tensile properties of composite materials is the interfacial adhesion between the matrix and the fibres [7]. Poor interface causes reduction of stress transmission from matrix to the fibre thus diminish the tensile strength of the biocomposite material. Tensile strengths for CR, C1 and C3 fibre reinforced composites were increased compared to the sample C2 because of its poor interface properties. As can be seen from our papers [6, 8] sample C3 shows the highest tensile strength, Young's modulus and elongation at break of 46.67 MPa, 2.60 GPa and 7.40 %, respectively pointing to strong and tough material. Mathematical modelling was used for prediction of micromechanical properties, which is very useful in composite designing process. Hirsch model offers relatively good correlation between experimental and predicted results, especially for tensile strength. Predicted tensile strength values were about 10 % lower in comparison to experimental values, except for sample C2, where predicted values are 113.5 % higher than experimental ones.

Flammability properties of tested composites investigated by MCC method revealed that nanoclay treated SJL fibres, which serve as an reinforcement in the sample C2 and C3, affect the occurrence of lower heat release values (W/g) indicating much higher flammability of CR and C1 samples. Table 4 shows corresponding combustion data of tested samples. It could be observed that materials reinforced with SJL fibres show lower peak heat release rate (HRR) and total heat release (THR) in comparison to the neat PLA. The formation of residue in Sample C2 after exposure to 750 °C affects the creation of a thermal barrier [9] that decreases the heat release of the nanoclay treated samples.

Table 4: MCC data of PLA and SJL composite materials where HRR is heat release rate, THR is total heat release and THC is total heat capacity. Results are presented as mean value within 95 % confidence interval

Samples	HRR (W/g)	THR (kJ/g)	THC, gas (kJ/g)	Yield of pyr. residue (g/g)
PLA	475.133±22.633	17.133±0.131	17.330±0.161	0.011±0.003
CR	388.400±24.894	14.433±0.653	15.160±0.436	0.048±0.035
C1	395.567±10.329	14.800±0.408	15.562±0.385	0.049±0.014
C2	280.926±16.735	13.833±0.663	14.581±1.212	0.074±0.006
C3	341.437±6.637	14.800±0.299	15.447±0.172	0.042±0.009

3.4 Biodegradability

Composite materials were subjected to enzymatic degradation in duration of three and five days. Composites reinforced with nanoclay modified fibres show higher biodegradation regarding the presence of excess -OH groups in MMT that may accelerate the hydrolytic decomposition responsible for degradation. C2 sample shows much higher value because of poor adhesion between PLA matrix and 2F fibre that is noticeable in Figure 3. It shows the linearity of PLA sample and polynomial regression of other tested samples regarding their weight loss/time function. According to prediction results, composite materials CR, C1, C2 and C3 will degrade by minimum of 90 % weight loss within 6 months of biodegradation treatment, more accurately within 114, 40, 8 and 36 days, respectively. PLA showed linear proportionality and it will degrade by minimum of 90 % weight loss within 315 days.

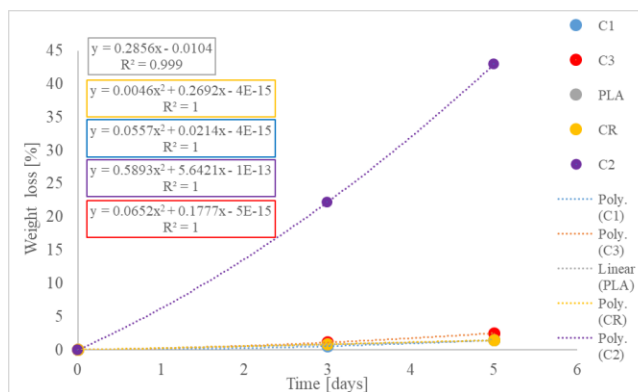

Figure 3: Linearity and polynomial regression of weight loss/time function for neat PLA and its composites when using 50 % of enzyme Savinase 16 L

3.5 Biofuels

After fibre extraction there is almost 90 % of organic residue from SJL plant which can be used as raw material for second-generation biofuel production. Proximate and ultimate analysis were conducted in order to determine energy properties of such biomass. Non-combustible matter content of residue after MW maceration shows low moisture content of 6.5 %, ash content below 5 % and higher fixed carbon value of 13.2 %, while combustible matter content is presented in Table 5.

Table 5: Combustible matter content with higher and lower heating values in the SJL residues after fibre extraction Where db – dry basis; VM – volatile matter; HHV – higher heating value; LHV – lower heating value; Different letters within a column indicate significant differences at the 5 % level; significance * $p < 0.05$, NS - non significant [10]

	Carbon (%)	Sulphur (%)	Hydrogen (%)	Oxygen (%)	VM (% db)	HHV (MJ/kg)	LHV (MJ/kg)
0_R	46.51 a ± 0.167	0.28 a ± 0.039	7.12 a ± 0.062	45.12 a ± 0.044	83.50 b ± 2.60	18.83 a ± 0.058	17.28 a ± 0.057
SW_R	43.46 c ± 0.127	0.29 a ± 0.010	6.07 a ± 0.918	49.80 a ± 0.793	77.76 a ± 1.85	17.23 a ± 0.122	15.90 ba ± 0.121
MW_R	44.13 b ± 0.039	0.18 ab ± 0.007	6.76 a ± 0.000	48.75 ba ± 0.050	75.52 a ± 2.64	18.16 a ± 1.112	16.69 a ± 1.112
Significance	< 0.05*	< 0.05*	0.1467 NS	< 0.05*	< 0.05*	0.0907 NS	0.1293 NS

Higher heating value for MW_R sample was 18.16 MJ/kg while lower heating value was 16.69 MJ/kg which indicates high quality biomass that can be used in solid biofuel production.

4. Conclusion

This research gives an insight into possible usage of *Spartium junceum* L. plant as a raw material for fibre production and its application as reinforcement in the composite material manufacturing. This research has examined the effects of surface functionalization of SJL fibres on the properties of natural fibre reinforced PLA composites, including thermal and mechanical behavior, biodegradability and agro-waste utilization.

The results of the present work confirm that the extraction process aided by microwave energy can be successfully used to produce fibres, with properties suitable for textile and composite applications inter alia automotive applications. Additionally, the fibre production time was significantly shortened and the energy consumption was notably lower.

The surface of SJL fibres was modified by alkali and nanoparticle treatment with the addition of environmentally friendly crosslinkers in order to enhance fibre/polymer interface and to achieve better flame retardancy. Composite materials reinforced with fibres of optimum quality show tensile strength and modulus improvement, as compared to the sample C2. The experimental values of composite tensile strength were compared to the values predicted by the Hirsch model and offer a relatively good correlation, since predicted tensile strength values were about 10 % lower in comparison to experimental ones. Biodegradability examination indicates significant biodegradation over 5-day test and 37 °C temperature. Sample C3 show weight loss of 2.5 % after 5-day test with the 50 wt.% enzyme, pointing to high probability of sample degradation by a minimum of 90 % of its weight/volume within period of 35 days.

SJL residues after fibre extraction proved to be good quality biomass for solid biofuel production based on the obtained results of moisture, ash, fixed carbon, coke, volatile matter, nitrogen, sulphur, carbon, hydrogen and oxygen content, as well as the obtained heating values, in order to achieve more efficient and sustainable production. Poverty reduction through the revitalization of SJL fibres would be a tangible outcome of the production of feedstock and the development of bioproducts.

References

- [1] Kovačević, Z.: Development of advanced polylactide nanobiocomposite reinforced with *Spartium junceum* L. fibres, *Doctoral dissertation*, University of Zagreb Faculty of Textile Technology, Zagreb, (2019)
- [2] Mokshina, N. et al.: Key Stages of Fiber Development as Determinants of Bast Fiber Yield and Quality, *Fibers* **6** (2018) 20, pp. 1-11, ISSN 2079-6439
- [3] Lewin, M.: *Handbook of Fiber Chemistry*, Taylor and Francis Group, LLC, ISBN 9780824725655, Boca Raton, US, (2006)
- [4] Abidi, N. et al.: Evaluating Cell Wall Structure and Composition of Developing Cotton Fibers using Fourier Transform Infrared Spectroscopy and Thermogravimetric Analysis, *Journal of Applied Polymer Science*, 107 (2008) 1, pp. 476-486, ISSN 0021-8995
- [5] Faruk, O. et al.: Progress report on natural fiber reinforced composites, *Macromolecular Materials and Engineering* **299** (2014) 1, pp. 9-26, ISSN 1439-2054
- [6] Kovacevic, Z. et al.: The influence of pre-treatment of *Spartium junceum* L. fibres on the structure and mechanical properties of PLA biocomposites, *Arabian Journal of Chemistry* **12** (2019) 4, pp. 449-463, ISSN 1878-5352
- [7] Oliver-Ortega, H. et al.: Tensile properties and micromechanical analysis of stone groundwood from softwood reinforced bio-based polyamide 11 composites, *Composites Science and Technology* **132** (2016), pp. 123-130, ISSN 0266-3538
- [8] Kovacevic, Z.; Bischof, S., Fan, M.: The influence of *Spartium junceum* L. fibres modified with montmorillonite nanoclay on the thermal properties of PLA biocomposites, *Composites Part B Engineering*, **78** (2015) 1, pp. 122-130, ISSN 1359-8368
- [9] Mclaggan, M. et al.: Heat release and flame spread assessment of insulation in External Thermal Insulation Composite System (ETICS) facades, 3rd European Symposium on Fire Safety Science, IOP Conference Series: *Journal of Physics: Conf. Series* **1107** (2018) 032021
- [10] Kovačević, Z. et al.: Spanish broom (*Spartium junceum* L.) – Feedstock for bioplastic and bioenergy industry, *The Hollistic Approach to Environment* **9** (2019) 3, pp. 44-52, ISSN 1848-0071

Acknowledgements

The research has received funding from the European Regional Development Fund via K.K.01.1.1.04.0091 project "Design of Advanced Biocomposites from Renewable Energy Sources – BIOCOSITES"

Authors:

Zorana KOVACEVIC, PhD.; (corresponding author); Prof. Sandra BISCHOF, PhD.
University of Zagreb Faculty of Textile Technology
Prilaz baruna Filipovica 28 a, 10000 Zagreb, Croatia
Phone: +385 1 4877 351

E-mail: zorana.kovacevic@ttf.unizg.hr;
E-mail: sbischof@ttf.unizg.hr

Prof Mizi FAN
Brunel University London
Kingston Lane Uxbridge Middlesex UB8 3PH
Phone: +44 (0) 1895 266466

E-mail: mizi.fan@brunel.ac.uk

PROPERTIES OF PA/COTTON YARNS ENHANCED BY THE SIZING PROCESS

Ivana VITLOV; Ivana SCHWARZ; Stana KOVAČEVIĆ & Snježana BRNADA

Abstract: Yarn sizing represents the most complex phase in the fabric production, due to the necessary multidisciplinary approach to the whole process, with the aim of achieving improvement in the yarn physical-mechanical parameters relevant for the further weaving process. Changes of the sizing parameters, of both, the sizing plant and the sizing conditions, greatly influence the sized yarn properties. This research deals with type of yarn (PA 6.6 / cotton) that are characterized by their abrasion resistance but at the same time by their durability, comfort, lightweight and strength. Despite these remarkable properties, subjecting these yarns to the sizing process enhance their properties relevant for further technological processes of fabrication in order to achieve maximum effects. This research shows the extent to which the sizing process influences the improvement of tested yarns properties and analyse the impact of various size mass concentrations and different sizing processes. The complete analysis is considered in the context of sizing process optimization and overall justification and acceptability.

Keywords: sizing process, size concentration, yarn properties, PA/cotton yarn.

1. Introduction

Weaving process success depends on many factors, of which the most important are the characteristics of the desired material, the sizing process and sizing conditions, yarn properties and sizing agents. The weaving process requires that the warp threads be firm, smooth and elastic to a certain degree, for the purpose of successful implementation of the entire process. Many yarns, even ply ones, after the spinning process do not have satisfactory enough properties to carry out the weaving process smoothly (due to the speeds increase of looms, which creates high stresses and require high yarn strengths), making the implementation of sizing process necessary, which further improves the yarn properties.

Extremely important yarn properties for the weaving process are yarn breaking properties and yarn abrasion resistance, because during the weaving process the yarn is subjected to stress and friction caused by metal parts of the loom, which cause damage to the yarn and breakage. Furthermore, the properties of elongation, abrasion resistance, elasticity and others are equally crucial for the high efficiency of the weaving process and the fabric quality. Elasticity and elongation are reduced by the sizing process, so the task of sizing is to achieve the smallest possible drop in elasticity and elongation in order to achieve oscillating periodic stresses, without the occurrence of permanent deformations [1,2].

These properties of sized yarn are largely conditioned by the influential parameters in the sizing process, the sizing conditions, as well as the sizing plant itself. Therefore, this research was conducted on a laboratory sizing machine, which enabled laboratory processing of samples by changing all the above mentioned parameters, with two sizing processes: standard sizing process and prewetting sizing process, while controlling and maintaining constant sizing conditions for all processed yarn samples [3,4].

2. Materials and methods

The materials used in this study are 2-ply yarns, raw material composition - mixtures of natural fibres with artificial fibres of synthetic polymers (polyamide fibre), with the basic characteristics shown in Table 1. The number of twists is an important parameter in the sizing process, because a higher number of twists leads to greater "closing" of the yarn, hinders the penetration of size into the yarn interior and keeping most of the size on the yarn surface. This can have significant consequences on the properties of the sized yarn [5,6].

Table 1: Basic characteristics of the tested samples

	Sample 1	Sample 2
Raw material composition	50% PA / 50% cotton	50% PA / 50% cotton
Finesses (Nm)	65/2	70/2
Twists (twist/m)	748,16	787,10

Standardized methods were used for testing the samples before and after sizing process. To determine the fineness of the yarn, the standardized standard HRN F.S2.015 was used. The twisting of the yarn was determined by the unwinding method on a MesdanLab Twist tester, according to the ISO 17202 standard. The determination of the breaking properties of the yarn was performed according to the ISO 2062 standard, on the dynamometer Statimat M tt. Textechno. The yarn abrasion resistance test (A, number of cycles) was performed on a Zweigle G551, where each of the 20 threads, under a load of 20 g, was simultaneously subjected to the process until breakage. The movement of the roller, coated with sandpaper of fineness 800, left-right and rotating around its axis, a certain intensity of abrasion is achieved between the yarn and the sandpaper. During the process, the thread weakens and at the moment when the mass of the weight suspended on the thread exceeds the strength of the yarn, a breakage occurs and the number of movements of the roller for the broken thread is registered [7].

The sizing mass used for both sizing processes was consisted of following agents: water, Fibrosint C75 (Pulcra Chemicals GmbH; synthetic polymers) and Inex 773C (Pulcra Chemicals GmbH; chemical composition: polyvinyl alcohol) in ratios depending on the concentration used for sizing (5%, 7% and 10%).

Sizing processes was performed on a laboratory sizing machine constructed at the University of Zagreb Faculty of Textile Technology (Figure 1), according to the conditions shown in Table 2 [8].

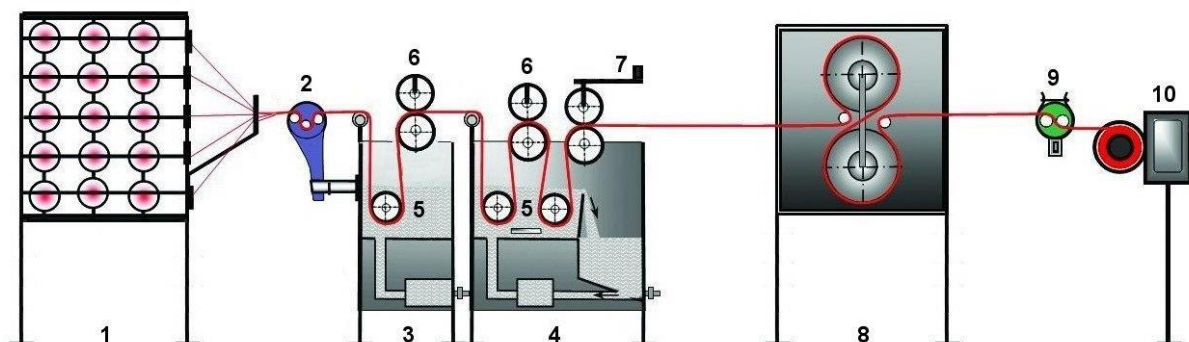

Figure 1: Laboratory sizing machine: 1 - creel for cross wound bobbins, 2 - yarn tension measuring device, 3 - prewetting box with hot water, 4 - sizing box, 5 - rollers for yarn immersion in water and sizing mass, 6 - rollers for squeezing out excess water and sizing mass, 7 - pressure regulation of the last squeezing roller, 8 - contact dryer, 9 - humidity measuring device, 10 - winder of the sized yarn [8]

Table 2: Sizing conditions during the sizing processes

Thread tension between creel for cross wound bobbins and prewetting box	40 cN
Water temperature in the prewetting box	65 °C
Size temperature in the sizing box	75 °C
Sizing speed	3 m/min
Pressure on the last rollers for squeezing out excess sizing mass	19,1 N/cm ²
Temperature on the contact dryer cylinders	140 °C

3. Results and discussion

The results of conducted tests of yarn breaking properties and abrasion resistance, before and after sizing, are graphically shown in Figures 2-5. For the tested properties, the arithmetic mean (\bar{x}) of individual measured values was calculated. Furthermore, the corresponding statistical indicators of variability - standard deviation (σ) and coefficient of variation (CV) as well as practical error limit (p_{99}) were calculated, which indicate good repeatability of results and sufficiency of measurements (Table 3).

The results of breaking force of unsized yarns show 16.2% higher value of Sample 1 (PA/cotton 65/2) compared to Sample 2 (PA/cotton 70/2). With the sizing process, the breaking force of the tested samples increases, but the ratio between the two yarn fineness's remains almost the same in all tested samples (on average 16.4%). The smallest increase in breaking force due to sizing in relation to non-sized yarn, in both tested samples shows yarns sized with sizing mass with concentration of 7%, on average 2.3% at standard sizing process and 4.2% in prewetting sizing process. These values are very similar for the tested samples

sized with sizing masses of concentration 5% and 10%, where they average 5.9% and 8.3%. From the above, it is easy to conclude that the prewetting sizing process shows better results in breaking force increase and the adequacy of the sizing mass concentration of 5%, which emphasizes the savings of sizing agents and other resources.

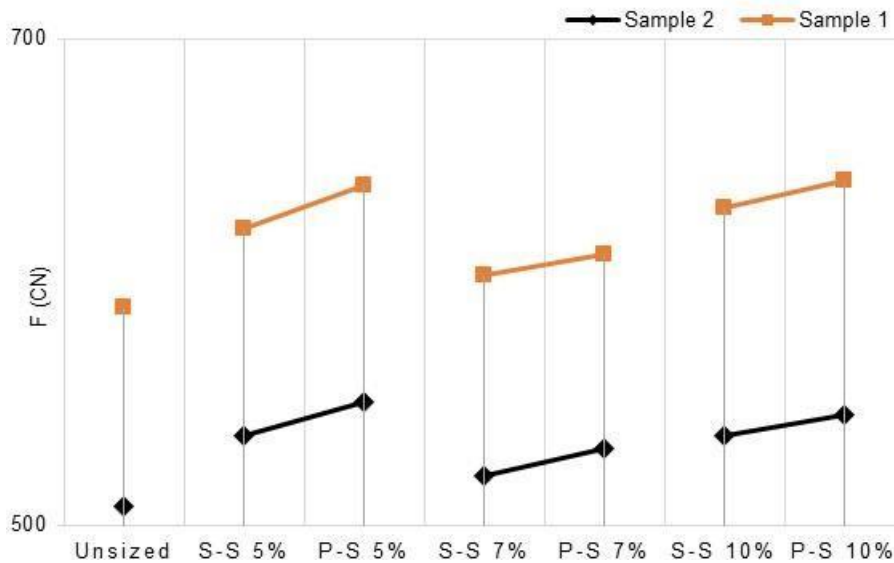

Figure 2: Diagram of breaking force of unsized and sized yarns; S-S - standard sizing process, P-S - prewetting sizing process; 5%, 7%, 10% - size mass concentration

According to the obtained results, it can be determined that the elongation at break is reduced by sizing, which represents a certain negativity of sizing process. The difference in elongation at break of unsized yarns is insignificant and amounts to slightly less than 2% in favour of Sample 1. However, this difference between two yarns, sized by the same process and the same concentration, increases and it is on average the same for yarns sized with concentration of 5% and 7% - 15% in standard sizing and twice less - 7% in the prewetting sizing process, also in favour of Sample 1. A significant difference between the two yarns occurs during sizing with a sizing mass concentration of 10%, namely 25% in standard sizing, and 40% in the prewetting sizing process. As the sizing mass concentration increases, the elongation at break of the yarn decreases. This reduction is even more pronounced in yarns sized by the prewetting sizing process. The smallest reduction in elongation at break was recorded for yarns sized with the lowest mass concentration (5%), namely 25% of Sample 2 yarns, while 15% of Sample 1 yarns.

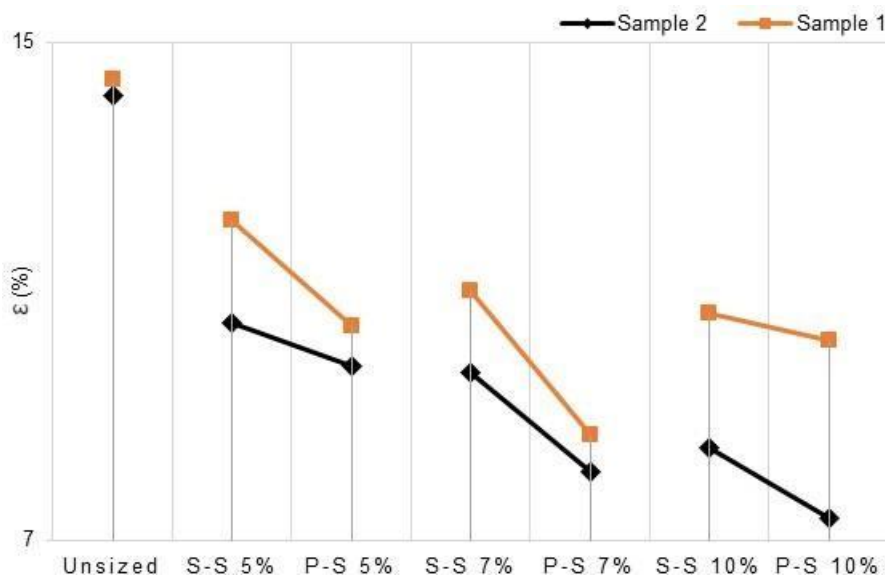

Figure 3: Diagram of elongation at break of unsized and sized yarns; S-S - standard sizing process, P-S - prewetting sizing process; 5%, 7%, 10% - size mass concentration

The difference in the tenacity of the unsized tested yarns is 11% and this ratio is maintained and reflected in the values of all sized yarns. Larger increases in tenacity is recorded at yarns sized with prewetting process at all sizing mass concentrations. Again, it is extremely important to point out that the most significant results are visible on yarns sized with the lowest mass concentration (5%), while the weakest results of tenacity increasing are recorded on yarns sized with a 7% sizing mass concentration.

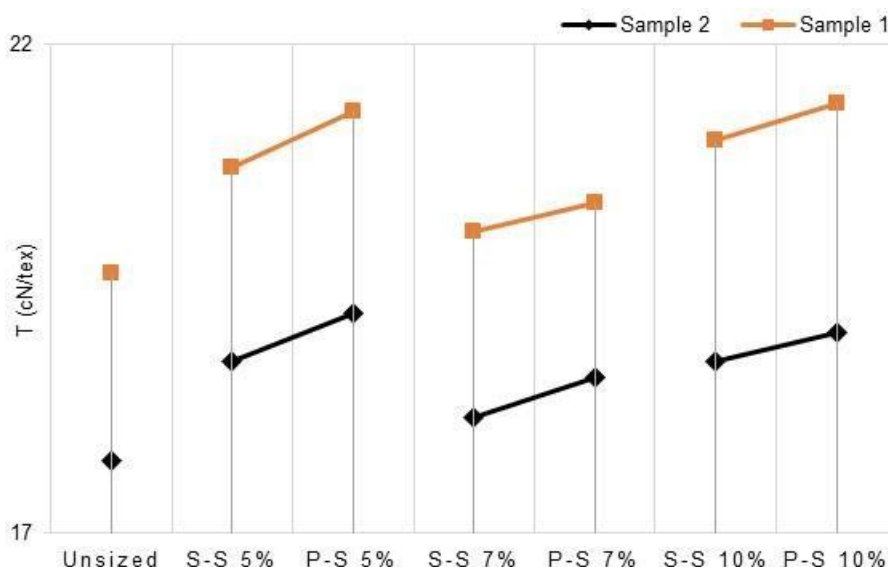

Figure 4: Diagram of tenacity of unsized and sized yarns; S-S - standard sizing process, P-S - prewetting sizing process; 5%, 7%, 10% - size mass concentration

The abrasion resistance of unsized yarns does not differ much, only 4%. However, sizing caused a significant difference between tested yarns, where Sample 1 yarns shows a greater increase in resistance by increasing the sizing mass concentration, as well as by applying the prewetting process. The most prominent results are the values obtained after sizing with a 10% mass concentration, namely by 55% for yarn sized by the standard process and by as much as 70% for yarn sized by the prewetting process.

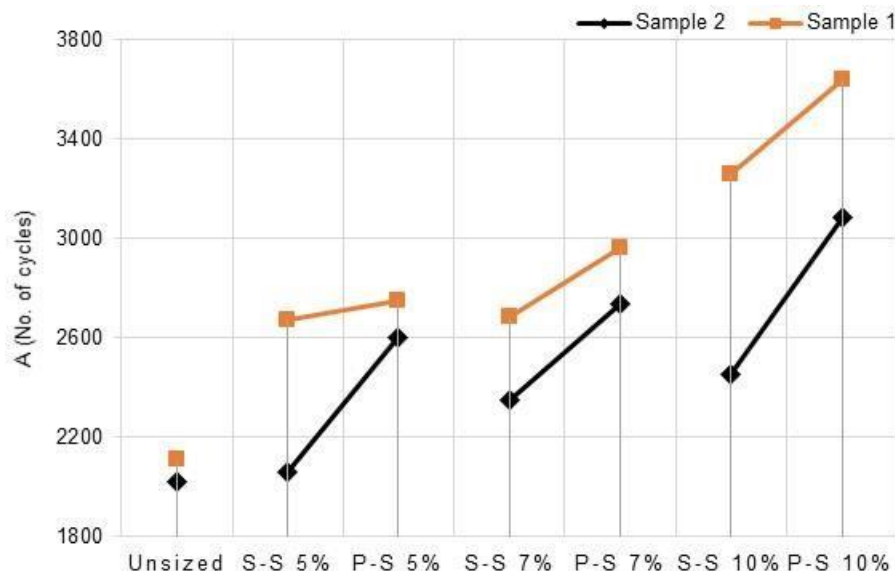

Figure 5: Diagram of abrasion resistance of unsized and sized yarns; S-S - standard sizing process, P-S - prewetting sizing process; 5%, 7%, 10% - size mass concentration

The conducted tests shows very interesting results (Figures 2-4), which were confirmed and supported by the performed statistical processing and analysis, where the indicators of variability and unreliability of the results are shown in Table 3.

Table 3: Statistical indicators of the values of the tested yarn samples

Property	Sample	Sample 1				Sample 2			
		\bar{X}	σ	CV (%)	p_{gg} (%)	\bar{X}	σ	CV (%)	p_{gg} (%)
F (N)	RAW	589.92	48.36	7.73	2.07	507.62	56.95	10.53	2.84
	S-S 5%	622.17	45.85	7.37	1.86	536.64	56.30	10.49	2.65
	P-S 5%	639.75	49.45	7.73	1.96	550.76	51.32	9.32	2.36
	S-S 7%	602.68	52.36	7.23	2.20	520.05	43.97	7.99	2.14
	P-S 7%	611.43	61.31	7.86	2.54	531.84	49.82	9.37	2.37
	S-S 10%	630.60	42.98	6.82	1.72	536.54	40.39	7.53	1.90
	P-S 10%	642.05	51.31	7.99	2.02	545.13	49.51	9.43	2.30
ϵ (%)	RAW	14.41	1.82	12.66	3.20	14.15	2.99	21.09	5.35
	S-S 5%	12.14	1.68	13.81	3.50	10.50	3.14	29.87	7.57
	P-S 5%	10.43	2.62	25.10	6.36	9.80	3.10	31.69	8.00
	S-S 7%	11.01	2.36	21.00	5.42	9.70	2.83	29.20	7.38
	P-S 7%	8.70	2.82	32.41	8.20	8.11	2.41	33.90	7.52
	S-S 10%	10.65	1.99	18.73	4.73	8.48	3.07	36.15	9.16
	P-S 10%	10.21	2.60	23.17	6.44	7.35	2.90	39.49	9.98
T (cN/Tex)	RAW	19.66	1.61	7.73	2.07	17.75	1.99	10.53	2.84
	S-S 5%	20.74	1.53	7.37	1.87	18.76	1.97	10.49	2.66
	P-S 5%	21.33	1.65	7.73	1.96	19.26	1.79	9.32	2.35
	S-S 7%	20.09	1.75	7.23	2.20	18.18	1.54	7.99	2.14
	P-S 7%	20.38	2.04	7.86	2.53	18.60	1.74	9.37	2.37
	S-S 10%	21.02	1.43	6.82	1.72	18.76	1.41	7.53	1.90
	P-S 10%	21.40	1.71	7.99	2.02	19.06	1.73	9.43	2.30
A (No. of cycles)	RAW	2108.30	648.08	30.74	7.78	2021.75	425.62	21.05	5.33
	S-S 5%	2674.40	586.58	21.93	5.55	2059.90	374.71	18.19	4.60
	P-S 5%	2748.70	425.94	15.50	3.92	2603.00	551.88	21.20	5.36
	S-S 7%	2683.10	690.00	25.72	6.51	2350.85	641.66	27.29	6.91
	P-S 7%	2960.00	483.35	16.33	4.13	2733.30	416.54	15.24	3.86
	S-S 10%	3258.40	938.21	28.79	7.29	2455.00	494.57	20.15	5.10
	P-S 10%	3641.20	597.98	16.42	4.16	3086.90	544.55	17.64	4.46

where: F (cN) - breaking force, ϵ (%) - elongation at break, T (cN/Tex) - tenacity, A (No. of cycles) - abrasion resistance, \bar{X} - mean value, σ - standard deviation, CV (%) - coefficient of variation, p_{gg} (%) - practical error limit

4. Conclusion

This research has once again proven that prewetting sizing improve the yarn mechanical properties to a greater extent than the standard sizing process. What is interesting and what stands out from previous researches (conducted on 100% cotton yarn) is the fact that better results (with the inevitable reduction of elongation at break) are shown by yarns sized with standard process. In this segment, the influence of 50% of the share of PA fibre in the mixture of tested yarns is evident.

It is also evident that the higher concentration of sizing mass does not result in better yarn properties (except in the case of abrasion resistance properties, where the results of sizing with 10% mass concentration significantly differs from the other two mass concentrations). On the contrary, the most significant results are those obtained by sizing with the lowest concentration of sizing mass (5%). This proves that the prewetting sizing process with a lower concentration of sizing mass, and thus a smaller amount of size pick-up, as well as with a lower consumption of sizing agents, water and energy, gives very good, satisfactory results.

Furthermore, despite the very small difference in the fineness of the tested yarns, it can be clearly seen that the Sample 1 yarn (PA/cotton 65/2) shows much better results after the sizing process, which can be attributed to the smaller number of yarn twists and thus easier penetration of the size into the interior of the yarn, giving it better "protection". In contrast, a higher number of twists in Sample 2 (PA/cotton 70/2) hinders the penetration of size into the yarn interior and results in higher retention of size on the yarn surface, resulting in insufficient increase of breaking force and tenacity, as well as stiffening yarn, reducing its elasticity. All of the above mentioned are extremely important indicators for the planning process of the entire technological process of weaving in terms of financial effects manifested in the segment of using all resources (yarns type, sizing agents, energy and water consumption) needed to implement the entire weaving process and obtain maximum quality of finished product.

Acknowledgment

This work has been fully supported by Croatian Science Foundation under the projects IP-2018-01-3170 Multifunctional woven composites for thermal protective clothing.

References

- [1] Adanur, S.: *Handbook of weaving*, Technomic Publishing Company, ISBN: 1- 58716-013-7 (2001)
- [2] Goswami, B.C.; Anandjiwala, R.D.; Hall, D.M.: *Textile Sizing*, Marcel Dekker, Inc., New York, Basel, ISBN: 0-8247-5053-5 (2004)
- [3] Kovačević, S.; Schwarz, I.; Skenderi, Z.: Diversity of spun yarn properties sized with and without prewetting, *Industria Textila* 67, 2, ISSN: 1222-5347, 91-98 (2016)
- [4] Sejri N. et al.: Influence of Pre-wetting on the Characteristics of a Sized Yarn, *Textile Research Journal* 78, (4), 326-335 (2008)
- [5] Lewin, M.: *Cotton Fiber Chemistry and Technology*, CRC Press, Taylor & Francis Group, Boca Raton, US, ISBN: 1-4200-4587-3 (2006)
- [6] Kovačević, S.; Gordoš, D.: Impact of the Level of Yarn Twist on Sized Yarn Properties, *Fibres & textiles in Eastern Europe* 17, 6, 44-49 (2009)
- [7] Saville, B.P.: *Physical testing of textiles*, The Textile Institute, Manchester, UK, Woodhead Publishing, Ltd, in association with the Textile Institute, ISBN: 0849305683 (1999)
- [8] Gudlin Schwarz, I.; Kovacevic, S.; Dimitrovsk, K.: Comparative Analysis of the Standard Sizing Process and the Pre-wet Sizing Process, *Fibres & Textiles in Eastern Europe* 19, (4), 87, 131-137, ISSN: 1230-3666 (2011)

Authors:

M. Sc. Ivana VITLOV
School of Applied Arts and Design
Perivoj V. Nazora 3/3, 23000 Zadar, Croatia

E-mail: ivana.vitlov@skole.hr

Assist. Prof. Ivana SCHWARZ, Ph. D. (corresponding author)
University of Zagreb Faculty of Textile Technology
Prilaz baruna Filipovića 28a, 10000 Zagreb, Croatia

E-mail: ivana.schwarz@tff.unizg.hr

Prof. Stana KOVAČEVIĆ, Ph. D.
University of Zagreb Faculty of Textile Technology
Prilaz baruna Filipovića 28a, 10000 Zagreb, Croatia

E-mail: stana.kovacevic@tff.unizg.hr

Assist. Snježana BRNADA, Ph. D.
University of Zagreb Faculty of Textile Technology
Prilaz baruna Filipovića 28a, 10000 Zagreb, Croatia

E-mail: sbrnada@tff.unizg.hr

RESEARCH ON WORKLOAD IN THE TECHNOLOGICAL SEWING PROCESS USING ANSI Z 365 STANDARDS

Snježana KIRIN & Anica HURSA ŠAJATOVIĆ

Abstract: *In the technological sewing process, the execution of technological operations is most often performed in a sitting working position. When sewing on the sewing machine, the worker uses the torso and hands to perform machine-hand and auxiliary-manual technological sub-operations, and the feet to achieve the required sewing speed of the sewing machine in machine-hand sewing sub-operations. Due to the physico-mechanical characteristics of the work pieces, careful handling is required, which needs extremely good motoric and tactile abilities of the worker, which are manifested in the mobility and coordination of movements of the fingers, hands, arms and feet. The paper presents a study of workload and musculoskeletal disorders on a sample of 50 workers in the technological sewing process using the ANSI Z 365 questionnaire (American National Standards Institute). According to the survey, the average age of the working population was 48 years, while the average length of employment in this type of work (sewing) was 22 years. The analysis of the questionnaire revealed that 76% of workers felt pain in the neck area, 58% in the left shoulder, 90% in the upper back, 72% in the middle back and 70% in the lower back. Research data show that workers in the sewing process due to their long sitting position with the required high degree of motoric coordination of the body, arms and legs, and because of the high repetitiveness of performing the same movements, feel pain in the cervical spine, shoulders and the entire back area. In order to reduce workload and at the same time pain after many years of working in the sitting position, it is necessary to design a workplace so that the worker can use the proper posture of the body and head when sitting.*

Keywords: *technological sewing process, workload, ANSI Z 365 standard.*

1. Introduction

In the technological sewing process, work is performed in the sitting position with the often forced position of the torso and head in front flexion, with isometric loading of the lower limbs (especially the feet), while high repetitive motion causes considerable dynamic loading of the fingers and hands [1, 2]. The type of technological operation, work method, sewing machine type, technical equipment of the sewing machine, and the system of work place installation affect the posture of the worker's body and the complexity of individual movements when performing the technological sewing operation. Work in an unfavourable working posture will cause a lower degree of execution accuracy, longer performing times of technological operations, higher workload and faster worker fatigue. In order to reduce workload and fatigue of workers in the technological sewing process, it is necessary to analyse workplaces, determine the causes of workload and fatigue, and provide guidelines for reducing workload.

Workers' workload in garment manufacturing systems is studied from different perspectives and is mainly based on subjective assessments and evaluations according to different questionnaires [3-6], and/or methods for analysing working positions OWAS (Ovaco Working Analysing System) [7,8], and / or RULA (Rapid Upper Limb Assessment) [9-11], and / or REBA (Rapid Entire Body Assessment) [12-14]. Studies have revealed that workers usually experience discomfort and/or pain in the region of neck, arms, spine and legs, leading to the occurrence of musculoskeletal disorders. The working posture of the worker in the technological sewing process is a static sitting posture characterized by the relatively uncomfortable posture of the joint systems: torso-head, upper leg-lower leg, lower leg-foot. Long-term static loads arising from repetitive use of the same muscle groups lead to joint damage (shoulder, hand), ligaments and tendons, and can lead to joint degeneration. Many years of work in an often unfavourable sitting position are the cause of discomfort, pain and damage to the musculoskeletal system, which significantly reduces work activity and quality of life.

In order to reduce workload and fatigue, it is necessary to redesign and/or design work places properly, and to find suitable work methods with a logical sequence of movements for a particular technological operation. By designing a workplace in the sewing process, it is necessary to achieve dimensional compliance of the man-machine-transport system, with the correct physiological sitting position, enabling fast and accurate motoric movements when starting the machine and guiding the work piece, a high degree of movement coordination, correct spine position and good head position. This reduces the performing time of the

technological operation, ensures quality, enhances productivity and allows the work to be done in a more favourable working posture, resulting in a lower level of workload.

Regularly workplace design includes adjusting the height of the seat, the height and size of the working surface, the position of the sewing machine pedal in relation to the worker's height, thereby achieving an ergonomically favourable arrangement of the work and visual zones that give the necessary dynamism and rhythm of work. In addition, the ability to perform simultaneous movements of arms, legs and body as well as a stable balance of the body when performing technological operations with the required visual zone and visual acuity is very important for workplace design. Determining a suitable working method means defining the method of performing movements of the worker when performing sub-operations in a technological operation, thereby achieving a more favourable structure of the technological operation, a uniform rhythm of work, and a lower level of worker load [2].

With proper and comprehensive workplace analysis and consideration of all the negative impacts on the worker, it is possible, with small investments and simple solutions, to secure workplaces with less workload and adverse effects on the worker.

2. Determining musculoskeletal disorders according to the ANSI Z 365 questionnaire

The analysis of the causes of the worker's workload in the technological sewing process according to ANSI (American National Standards Institute) can be conducted by investigation and analysing the comfort of body posture when performing certain technological operations using different questionnaires. Questionnaires consist of the representation of the body, so-called body map, with the classification of body parts into segments indicating the occurrence of difficulties or pains caused by unfavourable working postures [15, 16]. Figure 1 shows a body map for workload assessment according to the ANSI Z 365 questionnaire.

First and last name _____	0 - no pain 1 - low pain 2 - moderate pain 3 - severe pain 4 - continuous pain
Age _____	
Average height _____	
Length of service _____	
Length of service on this kind of job _____	

Figure 1: The body map for workload assessment according to the questionnaire ANSI Z 365 [16]

By filling out the questionnaire, the worker gives grades from zero to four to evaluate the level of pain of individual body parts. Grade zero means no pain or discomfort (comfortable), while grade four indicates persistent pain (continuous pain).

The analysis of the collected data using the questionnaire gives cognition about the body parts where symptoms of discomfort and pain are present, indicating a certain worker's workload when performing the technological sewing operation. Considering the level and frequency of discomfort and/or pain in a particular body part, an unfavourable working posture or movement may be identified. In order to reduce unfavourable working postures or movements and musculoskeletal disorders in the performance of the technological operation, it is necessary to redesign workplaces, and to develop optimal work methods that will reduce the worker's workload.

Furthermore, the ANSI Z 365 standard proposes to conduct a questionnaire and to evaluate factors that have an adverse consequences on the worker with respect to the time period of exposure such as repetitive technological operations, workload caused by handling the work piece, frequency of unfavourable postures of certain body parts and working environment. An in-depth analysis of the workplace can eliminate unfavourable working postures and movements, and realize a work with a suitable work method at a properly designed workplace.

3. Experimental part

The objective of this study was to examine and analyse the presence of musculoskeletal disorders of workers in the technological sewing process. For the purpose of detailed analysis of musculoskeletal disorders, the occurrence of symptoms of discomfort and pain on certain body parts was determined. The obtained data on the intensity of discomfort or pain in certain body parts were defined by a five-degree scale, and the occurrence of total symptoms of discomfort or pain was determined. Workload and musculoskeletal disorders were tested on a sample of 50 workers in the real manufacturing process.

An ANSI Z365 questionnaire was used to determine the presence of musculoskeletal disorders (Figure 1). It consists of a body map covering 21 body parts/body segments, containing information on body height, age, years of service and years of work on this kind of work.

The investigation was carried out in one working day. Before filling out the questionnaire, it was explained to the workers what kind of research it was, what the purpose of the research was, the questionnaire and the method of filling it out was explained.

4. Results

The basic principle of determining workload and musculoskeletal disorders using a questionnaire in this study is based on determining the level of discomfort or pain in workers when working at the sewing machine. Based on the questionnaire conducted on 50 workers in the technological sewing process, it was found that the average age of the surveyed working population was 48 years, average of the years of service 24 years, while the average years of service on this type of work (sewing) was 22 years. Table 1 gives an overview of the number and percentage of workers feeling a certain level of pain on individual body parts on a sample of 50 workers. Figure 2 shows a graphical representation of the total percentage of pain occurrence (1-4) with respect to body part.

Table 1: Data on the number and percentage of workers feeling a certain level of pain on individual body parts (0-no pain, 1-low pain, 2- moderate pain, 3- severe pain, 4-continuous pain)

No	Body part	Assessment of pain level									
		0-no pain		1-low pain		2-moderate pain		3-severe pain		4-continuous pain	
		N	%	N	%	N	%	N	%	N	%
1.	upper arm	45	90	5	10	0	0	0	0	0	0
2.	forearm	46	92	4	8	0	0	0	0	0	0
3.	thighs	40	80	6	12	0	0	4	8	0	0
4.	upper leg	39	78	11	22	0	0	0	0	0	0
5.	knee	36	72	3	6	7	14	0	0	4	8
6.	lower leg	44	88	6	12	0	0	0	0	0	0
7.	neck	12	24	7	14	22	44	6	12	3	6
8.	right shoulder	29	58	13	26	8	16	0	0	0	0
9.	right arm	43	86	0	0	7	14	0	0	0	0
10.	right hand	30	60	12	24	5	10	0	0	3	6
11.	right leg	37	74	3	6	4	8	3	6	3	6
12.	right foot	34	68	5	10	5	10	3	6	3	6
13.	left shoulder	21	42	17	34	7	14	5	10	0	0
14.	left arm	48	96	0	0	2	4	0	0	0	0
15.	left hand	35	70	6	12	9	18	0	0	0	0
16.	left leg	47	94	3	6	0	0	0	0	0	0
17.	left foot	41	82	5	10	4	8	0	0	0	0
18.	upper back	5	10	8	16	31	62	2	4	4	8
19.	middle back	14	28	8	16	24	48	0	0	4	8
20.	low back	15	30	4	8	23	46	4	8	4	8
21.	buttocks	32	64	7	14	8	16	0	0	3	6

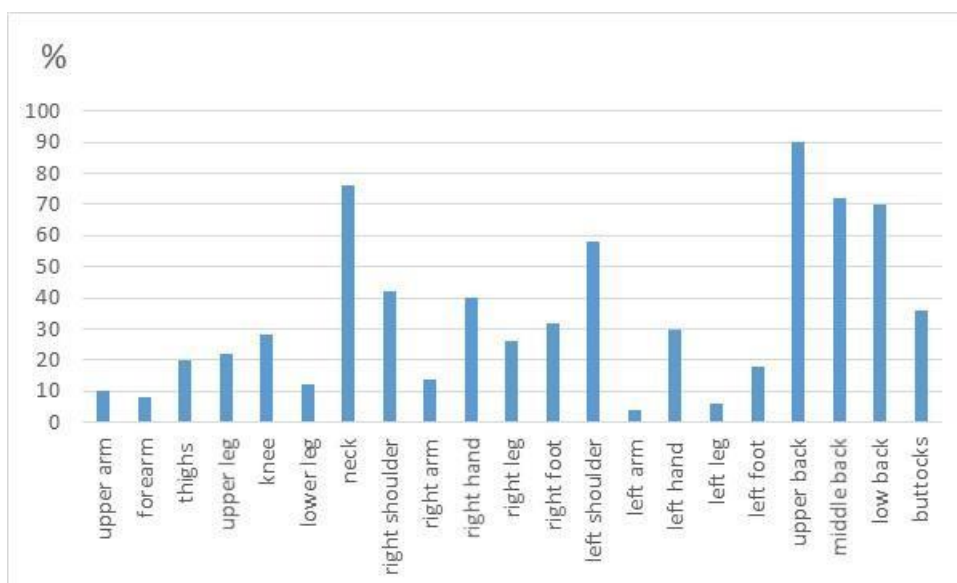

Figure 2: Total percentage of pain occurrence (1-4) with respect to the body part for all surveyed workers (N=50)

The analysis of the data obtained and presented in Table 1 and in Figure 2 showed that a large percentage of workers felt pain in the neck (76%), left shoulder (58%), upper back (90%), middle back (72%) and lower back (70%). They also felt pain in the right shoulder (42%), right hand (40%), right foot (32%), left hand (30%) and buttocks (36%). For other body parts the percentage of discomfort was below 30%.

Figure 3 gives a graphical representation of the percentage of occurrence of pain grades (0-4) with respect to the body part for all surveyed workers.

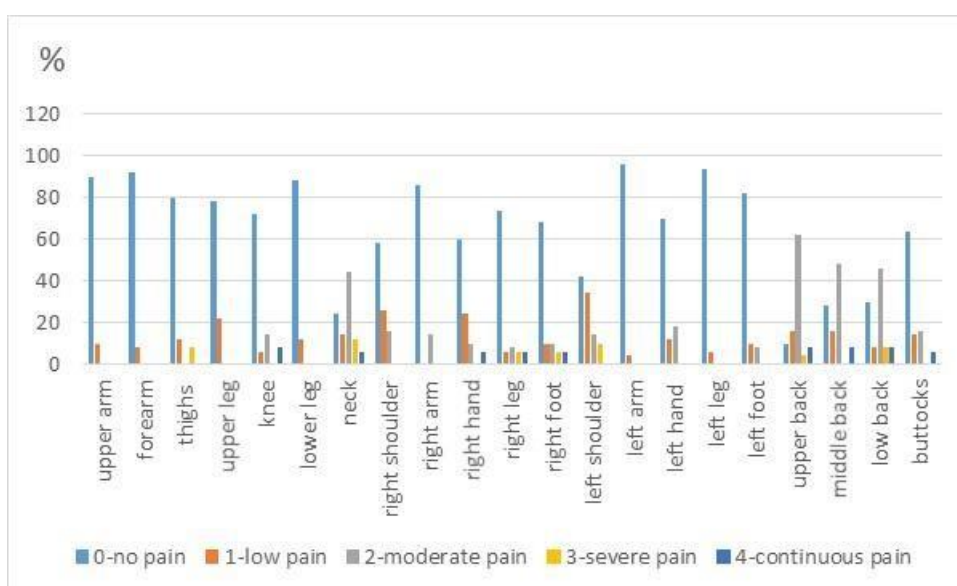

Figure 3: Percentage of occurrence of pain intensity (grades 0-4) with respect to the body part for all surveyed workers (N=50)

The analysis of the data obtained in Table 1 and Figure 3 revealed the conclusion that individual workers felt pain of varying intensity in several body parts. Due to pain intensity it is observable that the majority of workers felt low pain (grade 1) and moderate pain (grade 2).

The presented results (Figure 3) show that among 50 surveyed workers, 38 workers felt pain of varying intensity in the neck area, of which 22 workers (44%) felt moderate pain (grade 2). 29 workers felt pain of varying intensity in the left shoulder (grades 1, 2, and 3), while 17 workers (34%) felt low pain (grade 1). In the upper back, 45 workers felt pain of varying intensity, with 31 workers (62%) feeling moderate pain (grade 2). 36 workers declared for a different sense of pain in the middle back, of which 24 workers (48%) declared for

moderate pain (grade 2). 35 workers felt pain of varying intensity in the lower back, of which 23 workers (46%) felt moderate pain (grade 2). 13 workers (26%) felt low pain (grade 1) in the right shoulder, while 8 workers (16%) felt moderate pain. 20 workers felt pain of varying intensity in the right hand, of which 12 workers (24%) felt low pain (grade 1). 16 workers felt pain of varying intensity in the right foot, with 5 workers (10%) feeling low pain (grade 1), 5 workers (10%) feeling moderate pain (grade 2), 3 workers feeling severe pain (grade 3) and 3 workers (6%) feeling continuous pain (grade 4). 15 workers felt pain in the left hand, of which 9 workers (18%) felt moderate pain (grade 2). The workers felt pain of varying intensity in the buttocks, of which 8 workers (16%) felt moderate pain (grade 2). In other body parts pain was felt by a small number of surveyed workers.

Sitting in an unfavourable working posture with increased frontal flexion of the torso and head (neck) leads to excessive strain, resulting in a sense of pain in the shoulders, neck, and the entire back area, which was felt by a large percentage of the surveyed workers. The workers in the technological sewing process handle very flexible work pieces with a low mass per unit area, which results in loads of hands and fingers, since they always use the same muscle groups (one-sided dynamic work). Furthermore, technological operations are performed in a short time interval (15-60 s) with regular repetition of certain sub-operations and movements leading to damage to joints, ligaments, tendons and joint degeneration. The cause of unfavourable working posture and workload is due to unfavourable seat heights, seat backs, working surface heights and sewing machine pedal positions relative to the body height of the worker. Furthermore, incorrect and burdensome work methods when handling work pieces are the cause of workload, as well as ergonomically unfavourable movements that result from incorrect work piece arrangement on the working surface. Therefore, in order to reduce workload and the occurrence of musculoskeletal disorders, it is necessary to redesign individual workplaces, and to determine the appropriate work methods, allowing workers to use the proper posture of the body and head in the sitting position, thereby reducing workload and fatigue.

5. Conclusion

Workload and musculoskeletal disorders are significantly represent in workers in the technological sewing process, with the largest percentage present in the neck (76% or 38 workers), left shoulder (58% or 29 workers), right shoulder (42% or 21 workers), upper back (90% or 45 workers), middle back (72% or 36 workers) and lower back (70% or 35 workers).

Work places in the sewing process should be redesigned or adjusted to working surface height, seat height and sewing machine pedal position in relation to the worker's height. It would also be necessary to develop more favourable working methods for individual workplaces using the MTM (Method Time Measurement) system. Redesigning of work places and defining a more favourable work method should result in less load of the system: upper arm-forearm-hand, torso-thigh and lower leg-foot, in order to achieve a more stable sitting position. Proper workplace design can reduce the time of performing technological operations, workload and fatigue and the occurrence of musculoskeletal disorders in workers. Applying ergonomic principles of workplace design, systematic analysis of the impact of environment and machine on the worker, and using the most favourable working conditions can reduce the workers' workload and fatigue in manufacturing processes without higher costs.

The restriction of this study is caused by the sample size and number of younger worker. It is assumed that younger workers do not have a distinct occurrence of pain in certain body parts or pain intensity is lower.

References

- [1] Kirin, S.; Hursa Šajatović, A.: Defining standard sets of motions in the technological suboperation of sewing using the MTM-System, *Tekstil*, **Vol.67**, (2018), No.7-8, pp. 218-234, ISSN 0492-5882
- [2] Kirin, S.; Dragčević, Z.; Firšt Rogale, S: Workplace redesign in the computer-aided technological sewing process, *Tekstil*, **Vol. 63**, (2014), No.1-2, pp.14-26, ISSN 0492-5882
- [3] Kaergaard, A.; Anderson, H.: Musculoskeletal disorders of the neck and shoulders in female sewing machine operators: prevalence, incidence and prognosis, *Occupational and Environmental Medicine* **Vol.57**, (2000), No.8, pp. 528-534, ISSN 1351-0711
- [4] Schibye, B. et. al.: Musculoskeletal symptoms among sewing machine operators, *Scandinavian Journal Work Environment & Health*, **Vol.21**, (1995), No.2, pp.427-434, ISSN 1795-990X
- [5] Khan, A.R.; Khan, J.: Musculoskeletal Symptoms among Female Garments Worker: Working Environment; *Journal of Occupational Health*, **Vol.5**, (2018), No.2, pp. 1-7, ISSN 2374-6904
- [6] Maduagwu, SM., et. al.: Work-Related Musculoskeletal Disorders among Self-employed Sewing Machine Operators in Maiduguri, Nigeria, *Occupational Medicine & Health Affairs* **Vol.3**, (2015), No.5, pp. 2-7, ISSN 329-6879

- [7] Polajnar, A., Verhovnik, V.: *Oblikovanje dela in delovnih mest za delo v praksi*, Udžbenik Univerza v Mariboru, Fakulteta za strojništvo, ISBN 86-435-0305-3, Maribor, (1999)
- [8] Kirin, S.; Dragčević, Z.: Prilog istraživanju opterećenja radnika u tehnološkom procesu šivanja, *Zbornik radova 5. međunarodno znanstveno-stručnog savjetovanja Tekstilna znanost i gospodarstvo*, Ujević D. (Ur.), pp.171-174, ISSN 1847-2877, Zagreb, Hrvatska, siječanj, 2012., Sveučilište u Zagrebu Tekstilno-tehnološki fakultet, Zagreb (2012)
- [9] Öztürk, N.; Esin, M.N.: Investigation of musculoskeletal symptoms and ergonomics risk factors among female sewing machine operators in Turkey, *International Journal of Industrial Ergonomics* **Vol.41**, (2011), No.6, pp. 585-591, iISSN 0169-8141
- [10] Kirin, S.; Dragčević, Z.: Investigation of Workload in the Technological Sewing Process Using the RULA Method, *Proceedings of the 9th International Textile, Clothing & Design Conference-Magic World of Textiles*, Dragčević Z. (Ed.), pp. 197-202, ISSN 1847-7275, Dubrovnik, October, 2018, University of Zagreb, Faculty of Textile Technology, Dubrovnik, Croatia, (2018),
- [11] Dianat, I.; Karimi, A.M.: Musculoskeletal symptoms among handicraft workers engaged in hand sewing tasks, *Journal of Occupational Health*, **Vol.58**, (2016), No.6, pp. 644-652, ISSN 1348-9585
- [12] Polat, O.; Kalayci, C., B.: Ergonomic Risk assessment of Workers in Garment industry, Available from <https://www.researchgate.net/publication/309321719>, Accessed 2020-01-20
- [13] Isler, M.; Küçük, M.; Guner, M.: Ergonomic assessment of working postures in clothing sector with scientific observation methods, *International Journal of Clothing Science and Technology*, **Vol.30**, (2018), No.6, pp. 757-771, ISSN 0955-6222
- [14] Kirin, S.: Ergonomska procjena opterećenja radnika u tehnološkom procesu šivanja REBA metodom, *Proceedings of 12th International Scientific Conference on Production Engineering-Development and Modernization of Production*, Hodžić, A., Islamović F., Mijović, B. (Ed.), pp.372-377, ISSN 2566-328; Sarajevo, Rujan, 2019, Univerzitet u Bihaću Tehnički fakultet, Sarajevo, (2019)
- [15] Harris-Carter G.: A Practical Guide to Work Site Analysis, *Bobbin*, (1994), No.12, pp. 57-61
- [16] Kirin, S.; Dragčević, Z.; Polajnar, A.: Radno opterećenje i zamor u tehnološkom procesu šivanja, *Tekstil*, **Vol.53**, (2004.), No.5, pp.226-243, ISSN 0492-5882

Authors:

Snježana KIRIN, M.Sc. (corresponding author)

Karlovac University of Applied Sciences

J. J. Strossmayer's Square 9, 47000 Karlovac, Croatia

Phone: +(385) (47) 843 581

Fax: +(385) (47) 843 579

E-mail: snjezana.kirin@vuka.hr

Assoc. Prof. Anica HURSA ŠAJATOVIĆ, Ph.D.

University of Zagreb, Faculty of Textile Technology, Department of Clothing Technology

Prilaz baruna Filipovića 28a, HR-10000 Zagreb, Croatia

Phone: +(385) (1) 3712 551

Fax: +(385) (1) 3712 535

E-mail: anica.hursa@ttf.unizg.hr

APLICACION OF MICROSCALE COMBUSTION CALORIMETER TO CHARACTERIZE PROTECTIVE PROPERTIES OF BOVINE LEATHER

Franka ŽUVELA BOŠNJAK; Sandra FLINČEC GRGAC & Suzana MIHANOVIĆ

Abstract: *The quality and properties of fire resistance are crucial to the selection of leather for the production of protective fire fighting boots, which has a primarily protective role. During fire extinguishing it is exposed to extremely high and low temperatures, chemicals (acids and alkalis), mechanical loads, etc. The properties of fire resistance were tested on two samples of bovine leather (BL1, BL2). Burn resistance test has been carried out in accordance with the requirements of the technical standards for the burn resistance test: HRN EN ISO 15090: 2012, t, 7.3 - Firefighters and rescue services. The mentioned two samples were individually tested according to HRN EN ISO 15025: 2003. The test procedure was carried out by the "Flame Expansion Testing Method". Moreover, in this research used Microscale Combustion Calorimeter (MCC) Govmark, UK because that was designed for produce the maximum heating rate capability similarly the heating rates in fires and give as a lot of flammability parameters. The analysis of physicochemical properties of samples was performed using Fourier transform infrared (FT-IR) spectroscopy. The surface morphology of the samples was studied using a Field Emission Scanning Electron Microscopy (FE-SEM). The measurement of the above samples on MCC was performed according to ASTM D7309. From the obtained HRR results, it is evident that BL1 sample has a better thermal stability than the BL2 sample.*

Keywords: *bovine leather, fire resistance, MCC analysis, FTIR-ATR, FE-SEM*

1. Introduction

The occupational hazards that are presented in protection industry pose a number potential risk for injuries. Wearing personal protective equipment is the only, irreplaceable protection for profession who are exposed to multiple hazards. Fire fighting boots are important part of special protective equipment. They protect firefighters not only from flame and high heat, but also from exposure to hazardous liquid, physical, and electrical hazards [1]. Leather goods have played a major role in protecting the human body from external influences from the existence of human race. Skins have to be treated with many processes including soaking, degreasing, unhairing, liming, picking, tanning, retanning, fatliquoring and finishing to achieve finished and utility leather. During these processes, many different materials were added in the leather tissue and therefore would influence the flammability of leather. Among those treatments, tanning is one of the most important factors that affect fire retardance of leather [2].

The most important feature of leather is its fibrous structure. Leather is characterised by a high permeability for water vapour and other gases and, at the same time, very low water permeability. The characteristic structure of leather can explain many properties of tanned leather such as tear resistance, flexibility, permeability for air, thermal insulation, resistance to water and shape maintenance [3]. However, leather is a natural material considered a very high-tech product that is progressively being used to a larger extent in different sectors: automotive, domestic upholstery, buildings, aviation, maritime, personal safety, etc. [4].

Bovine leather has generally firm and tight collagen tissue, especially in the back parts. In this type of leather, the papillary layer is loosely constructed and is relatively small compared to the reticular layer. Bovine leather of such structure is used for the production of leather, which have high resistance to mechanical stresses [5]. Fire resistant boots are made mostly of the bovine box. Leather box, tanned with chrome or in combination with chrome and other types of tanning agents, are used for making tops of footwear and other products. They are made mostly with a smooth, natural face and broken or embossed face. The main characteristics of leather box are: fullness, flexibility, softness, good strength, elasticity and thick texture of leather tissue. These properties are connected with fibrous structure of leather tissue constructed of collagen fibers, depending on the type and quality of the raw material and on the performed technological processing operations [5]. Parts of leather from back of the animal is most commonly used for footwear parts that are exposed to the greatest mechanical and thermal influences. The reason for these properties is fibrous structure of the finished leather, which consists of nettle fibers and fibrils. The more vertical fibers make leather tissue more firm and thicker. The back of the leather abounds with collagen and this part of the leather tissue is the strongest and the most densely which provides good mechanical and thermal properties to the objects made by it [6].

Flame resistant fabrics for industrial and military uses represent one of a few most profitable niche markets in the global textile complex. Most of the textile materials, are flammable, therefore applying flame retardants to textile fabrics becomes necessary to assure human safety under many circumstances [7].

Leather is more fire resistant than textile but every type of leather don't have good flame resistance. It depend on type of leather, type of processing and also final finishing of leather. In this research, burn resistance test carried out by the "Flame Expansion Testing Method" and Microscale Combustion Calorimeter (MCC) has been applied, for determining the flammability of two different leather samples used for fire fighting boots to get flammability parameters for assessment usability leather.

2. Materials and methods

2.1 Materials

Two samples of bovine leather were subjected to heat stability and burn (flame) resistance testing. First sample is fireproof bovine box (BL1), 2.3-2.5 mm thick, most commonly used for upper part of firefighting boots. Second sample is perforated bovine leather (BL2) with corrected grain and polyurethane finish are most commonly used for collar of fire fighters' boots. Both leather samples are dyed in black.

2.2 Methods

2.2.1 FT-IR spectroscopy

The analysis of physicochemical properties of samples was performed using attenuated total reflectance (ATR) Fourier transform infrared (FT-IR) spectroscopy (Perkin Elmer, software Spectrum 100). Four scans were done for each sample, at the resolution of 4 cm⁻¹ between 4000 cm⁻¹ and 380 cm⁻¹.

2.2.2 MCC measurement

The MCC measurement was performed using an "MCC-2" micro-scale combustion calorimeter produced by Govmark, Farmingdale, New York, according to ASTM D7309-2007 (Method A). To improve sample uniformity, the leather were first ground in a Wiley mill to form homogeneous powders. The sample thus prepared (fiber powder), approximately 5 mg, was heated to a specified temperature using a linear heating rate of 1 °C/s in a stream of nitrogen flowing at 80 cm³/min flow rate. The thermal degradation products (fuel gases) were mixed with a 20 cm³/min stream of oxygen prior to entering a 900 °C combustion furnace. Each sample was run in three replicates and the data presented here are the averages of the three measurements. The combustion of fuel gases in the mixture of 20% O₂ and 80% N₂ at 900 °C for 10 s is a very conservative condition to ensure complete oxidation of the fuel gas [8]. All curves presented in this paper show no saturation of HRR, confirming the complete oxidation of the fuel gases. In this research, the MCC experiments are performed according to "Method A" of ASTM 7309, which specifies that the degradation of samples takes place in nitrogen atmosphere [7].

2.2.3 Burn resistance test

Test conducted in accordance with HRN EN ISO 15025: 2003.[9]. The samples were subjected to a standard atmospheric temperature of 23 ° C (± 2 ° C) and a relative humidity of 50% (± 5%) prior to testing.

2.2.4 Scanning Electron Microscopy (SEM)

Besides the physical-chemicals characterization of samples, the leather surface morphology of the grain surface and flesh side surface was observed with MIRA, LMU Tescan, field emission scanning electron microscope (FE-SEM). The samples were mounted on stubs and coated for 240 s with chromium in a sputter coater Quorum-Q150T ES.

3. Results and discussion

3.1 FT-IR spectroscopy measurement

To determine protein structure and dynamics of structure infrared spectral band frequency, band intensity, and band width can be used. Using infrared spectroscopy for protein structure analysis the vibration of the protein amide bonds are the concrete indicators [10]. FT-IR analysis of leather samples implies infrared radiation to

assess vibrational modes particular for protein molecules and relating this to the primary, secondary, tertiary, and quaternary structure of the protein.

Two main bands of the collagen are Amide I and Amide II bands. The Amide I band ($\sim 1650\text{ cm}^{-1}$), (70-85%) is determined by the backbone conformation and the hydrogen bonding pattern and it is mainly associated with the C=O stretching vibration. Amide II ($\sim 1550\text{ cm}^{-1}$) results from the N-H bending vibration and from the C-N stretching vibration. Amide III ($\sim 1235\text{ cm}^{-1}$) depending on hydrogen bonding and on side chains of collagen structure [11].

Results also point characteristic pikes for polyurethane. $2927\text{-}2854\text{ cm}^{-1}$ corresponds to the methylene group (-CH₂-). Between $1705\text{-}1691\text{ cm}^{-1}$ the hard segments carbonyl bands can be observed. The C-N stretching bands, combined with those of the bending of N-H, are typically observed at 1523 cm^{-1} and 1446 cm^{-1} , demonstrating the occurrence of the reaction between the hydroxyl group and the isocyanate [11]. These results confirm that both leather samples contain in their structure both grain and flesh sides polyurethane compound.

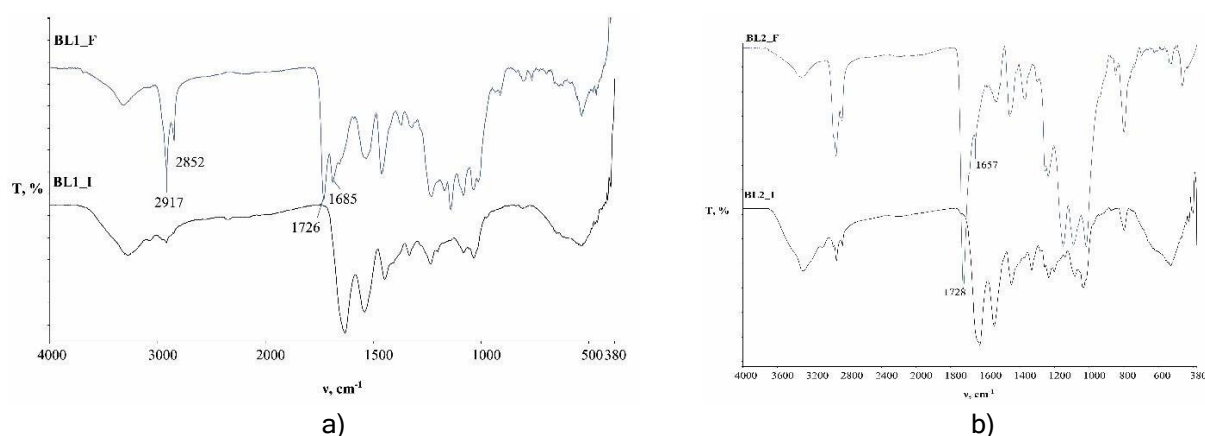

Figure 1: FT-IR spectrum curves of BL1 (a) and BL2 (b)

3.2 Results of MCC measurement

Table 1 shows the values that are extremely important for the characterization of samples intended for firefighting footwear with respect to the heat and flame resistance obtained by analysis at the MCC.

Table 1: Results of MCC analysis of BL1 and BL2 samples

	BL1			BL2		
	\bar{X}	s	CV %	\bar{X}	s	CV %
Heat release capacity, Γ_c (kJ/g)	82,00	1,73	0,021123	85,00	1,00	0,011765
Maximum specific heat release, Q_{max} (W/g)	81,39	1,25	0,015302	86,00	1,14	0,013295
Heat release temperature, T_{max} (°C)	400,60	0,98	0,002459	379,10	2,77	0,007315
Specific heat release, h_c (kJ/g)	8,53	0,45	0,052843	10,40	0,61	0,058488
Yield of pyrolysis residue, Y_p (g/g)	1,27	0,18	0,141732	1,17	0,05	0,038651
Average release capacity, Γ_c (kJ/g)	93,67	3,79	0,040419	92,00	0,00	0
Average release temperature T_{max} (°C)	349,27	0,55	0,001577	347,27	0,85	0,002449

In order to characterize as accurately as possible, the leather samples BL1 and BL2 with respect to the behaviour under the action of heat were subjected to analysis on an MCC device. From Table 1 we can see that sample BL1 has a mean maximum specific heat released (81.39 Wg^{-1}) lower than sample BL2 (86 Wg^{-1}). An indicator of the thermal stability of the samples is the amount of charred residue after analysis, and it can be seen that the sample BL1 ($1,27\text{ gg}^{-1}$) has a slightly larger residue compared to the sample BL2 ($1,17\text{ gg}^{-1}$). From all the above, it can be concluded that the BL1 sample shows slightly better heat resistance results. However, both samples show good thermal stability results.

3.3 Results of fire resistance test

After fire extinguishing, none of the samples continued to burn. Finished fireproof leather of the BL1 bovine box was not damaged and is the ideal material for the firefighter's upper parts of footwear. BL2, the perforated bovine fireproof leather with the artificial face is partially coated and shrunken in the centre (Figure 2.), where it was exposed to flame.

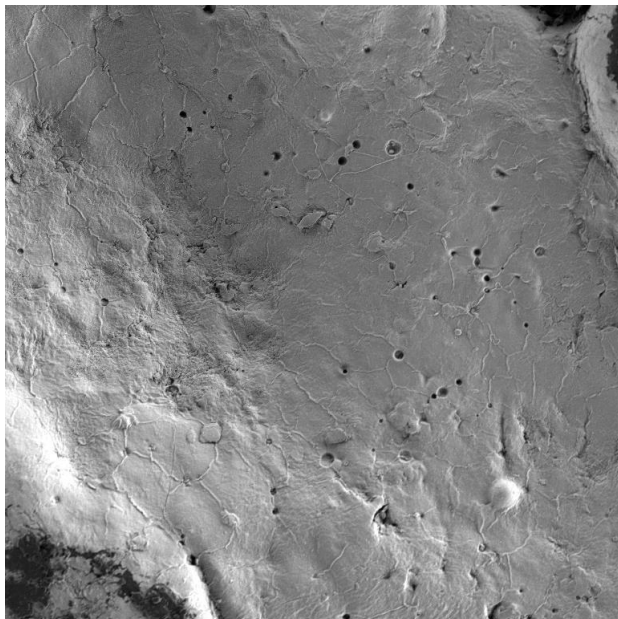

Figure 2: Burning procese according to HRN EN ISO 15025: 2003

3.4 Results of Scanning Electron Microscopy (SEM)

The morphological characterization of the surface was analysed by FE-SEM in order to try to identify the difference of the structures between BL1 and BL2 samples on grain side and flesh side. Figure 3 a) and b) show the grain side surface of sample BL1 with magnifications 1000x and 5000x. It can be seen polyurethane adhesive applied to the natural face of the leather, which covers the natural face characteristics. Figure 4: a) and b) shows the grain side surface of sample BL2. The face of this sample is artificial, polyurethane finish applied on splited leather. The finish layer on grain side of BL2 is more uneven and irregular, which can be attributed to the characteristics of the application itself, i.e. the finish. The larger layer of finish gives a more closed face structure and visible irregularities.

Figure 3 c) and d) show the flash side of sample BL1 while figure 4 shows the flesh side of sample BL2. Comparing these sides of two samples it can be concluded that BL1 sample is more compact. The flesh side of the BL2 sample is brushed, so the fibre bundles are evenly oriented and without tangled dirt.



SEM HV: 5.00 kV WD: 4.993 mm
View field: 216.7 μ m Det: BSE
SEM MAG: 1.00 kx Date(m/d/y): 06/29/18
MIRA\ TESCAN
Performance in nanospace

a

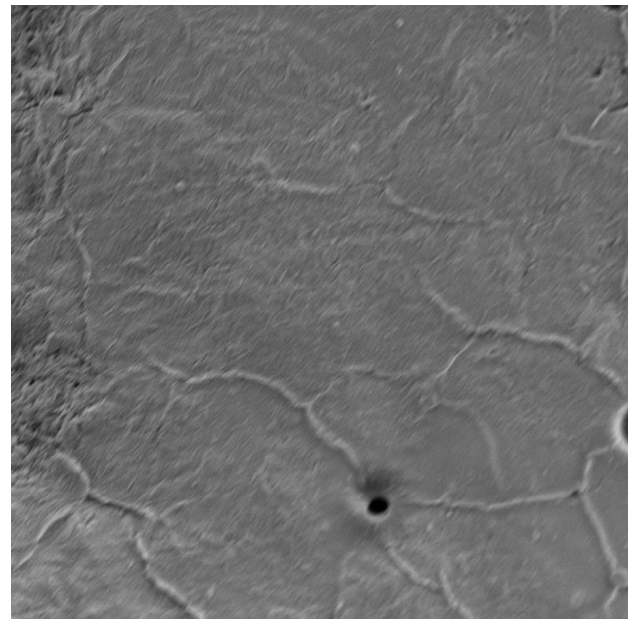

SEM HV: 5.00 kV WD: 4.993 mm
View field: 43.34 μ m Det: BSE
SEM MAG: 5.00 kx Date(m/d/y): 06/29/18
MIRA\ TESCAN
Performance in nanospace

b

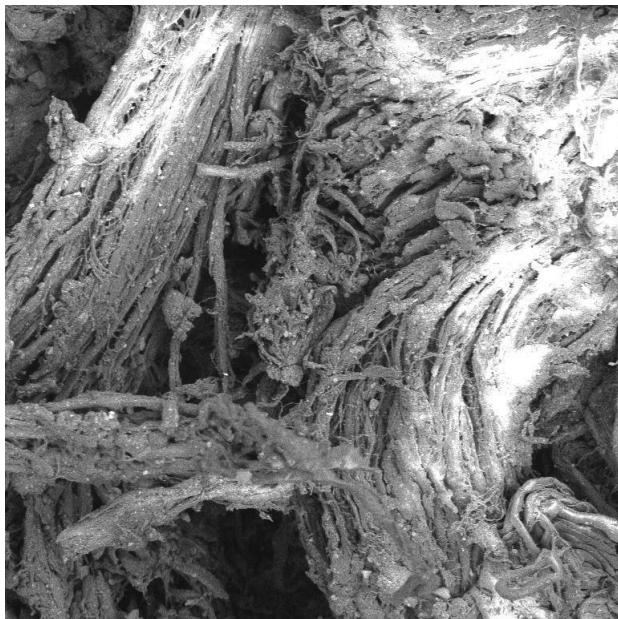

SEM HV: 5.00 kV WD: 10.00 mm
View field: 216.7 μ m Det: BSE
SEM MAG: 1.00 kx Date(m/d/y): 06/29/18
MIRA\ TESCAN
Performance in nanospace

c

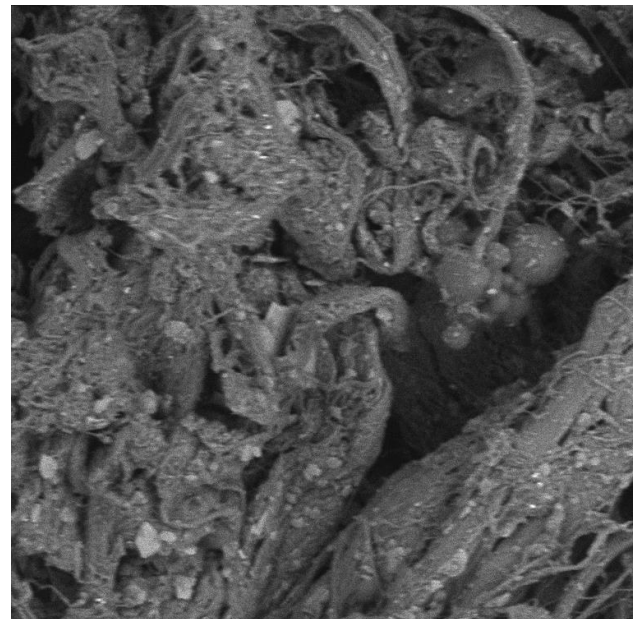

SEM HV: 5.00 kV WD: 10.01 mm
View field: 43.35 μ m Det: BSE
SEM MAG: 5.00 kx Date(m/d/y): 06/29/18
MIRA\ TESCAN
Performance in nanospace

d

Figure 3: Morphology of the grain surface (a, b) and flesh side surface (c,d) sample BL1 at different magnifications: a, c - 1000x; b,d - 5000x

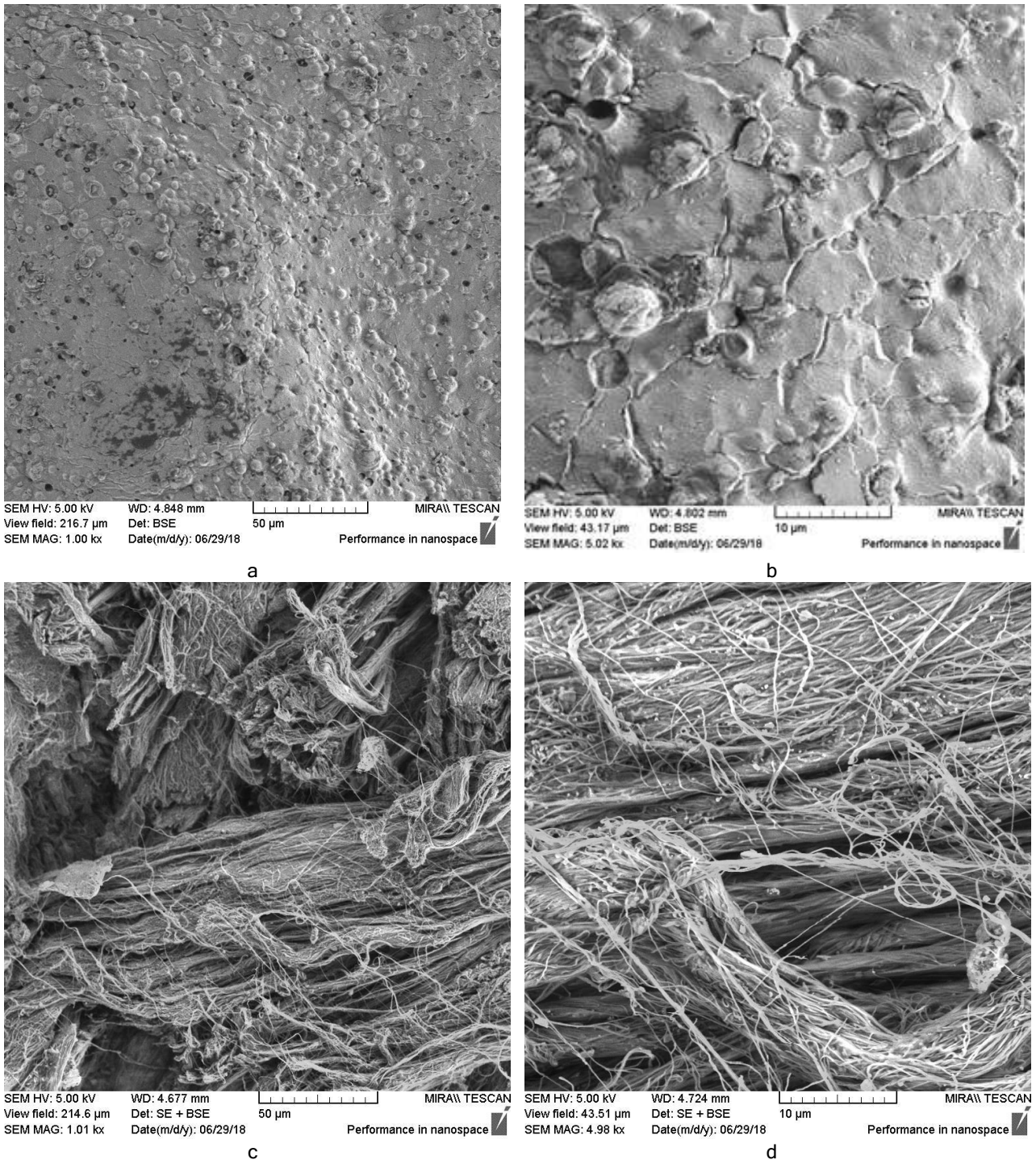

Figure 4: Morphology of the grain surface (a, b) and flesh side surface (c,d) sample BL2 at different magnifications: a, c - 1000x; b,d - 5000x

4. Conclusion

Infrared spectroscopy confirm Amide I, Amide II, and Amide III bonding's which are normally present in collagen structure. Results also show polyurethane compounds in both samples, on grain and flesh side which confirm that both samples have polyurethane finish in their structure. MCC results for BL1 sample show slightly better heat resistance but it can be concluded that both samples have good thermal stability. The morphological characterization of the surface analysed by FE-SEM showed a visible difference between the face sides of the samples. Natural face characteristics are not visible on any of the sample. BL2 has an artificial face, so it shows a more closed structure and more irregularities caused by artificial layers on split leather. Sample BL2 have cleaner flesh side without dirt than BL1.

Sample BL1 shows greater stability to the action of open flames and as such is much more suitable for the manufacture of fire fighter boots. Sample BL2 is used only for collar of fire fighters boots not for whole boots.

Acknowledgments

The research is conducted from support for research 2020. Finishing and maintenance of textiles and leather with environmentally friendly agents, Assist. Prof. Tihana Dekanić

References

- [1] Irzmańska, E.: The microclimate in protective fire fighter footwear: Foot temperature and air temperature and relative humidity, *Autex Research Journal*, **16** (2016) 2, pp. 75-79, ISSN: 2300-0929
- [2] Fan, C.; et al: Influence of retanning materials with different properties on the flammability of leather, *Leather and Footwear Journal*, **13** (2013) 3, pp. 179-186, ISSN: 1583-4433
- [3] <http://www.leathermag.com/features/featureflammability-and-flame-retardancy-of-leather/>, Accessed: 2020-02-28
- [4] Bacardit, A.; Behavior of Leather as a Protective Heat Barrier and Fire Resistant Material, *Journal-American Leather Chemists Association*, **105** (2010), pp. 51-61, ISSN: 00029726
- [5] Grgurić, H.; Vuković, T.; Bajza, Ž.: *Tehnologija kože i krzna*, Zajednica kem., kožarskih, obučarskih, gum. i rud. organizacija, Zagreb, (1985)
- [6] Radanović, Z.: *Poznavanje kožarskih materijala i njihovo ispitivanje*, Zagreb, (1989)
- [7] Q. Yang, C. et al; Investigation of the flammability of different textile fabrics using micro-scale combustion calorimetry, *Polymer Degradation and Stability*, **95** (2010), pp. 108-115, ISSN: 01413910
- [8] Lyon, R.; Walters, R.; Stoliarov, S.; Thermal analysis of flammability, *Journal of Thermal Analysis and Calorimetry*, **89** (2007) 2, pp. 441-448, ISSN: 15882926, 13886150
- [9] HRN EN ISO 15025:2003. Zaštitna odjeća - Zaštita od topline i plamena - Metoda ispitivanja za ograničeno širenje plamena
- [10] Sendrea, C. et al: Non-invasive characterisation of collagen based on materials by NMR-MOUSE and ATR-RTIR, *UPB Scientific Bulletin, Series B: Chemistry and Materials Science* open access, **78** (2016), pp. 27-38, ISSN: 14542331
- [11] S. Gregori Valdés, B. et al: New Biocompatible Polyurethanes: Synthesis, Structural Characterization and Cytotoxicity, (2018) 2018090445, doi:10.20944/preprints201809.0445.v1

Authors:

Dipl.ing. Franka Žuvela Bošnjak
University of Zagreb Faculty of Textile Technology
Study in Varaždin
Hallerova aleja 6
42000 Varaždin

Tel: +(385) (42) 33 06 76 Fax: +(385) (42) 33 04 50

E-mail: franka.zuvela.bosnjak@ttf.hr

Assist. Prof. Sandra Flinčec Grgac, PhD.
University of Zagreb Faculty of Textile Technology
Prilaz baruna Filipovića 28a
HR-10000 Zagreb

Tel: +(385) (1) 48 77 358 Fax: +(385) (1) 37 12 599

E-mail: sflincec@ttf.hr

Dipl.ing. Suzana Mihanović
Psunj d.o.o.
Kožarska 18,35403, Rešetari
Tel: +(385) (35) 364-215

Fax: +(385) (42) 367-373

E-mail: productioni@viani.hr

RESULTS OF CHITOSAN FIBRES FORMATION BY WET SPINNING METHOD IN A HIGH-EFFICIENCY LABORATORY SET

César Israel HERNÁNDEZ VÁZQUEZ; Zbigniew DRACZYŃSKI & Grzegorz SZPARAGA

Abstract: *The chitosan fibres were obtained by a wet spinning method; chitosan solutions were prepared at a chitosan concentration of 6% which based on the dynamic viscosity shown to be the most suitable for spinneret flowing process; for coagulation it was used NaOH at different concentrations (1%, 2%, 4% and 5%) as well as in the stretching bath (0,5 % NaOH), for the final part of the process a rinse bath containing pure ethanol was used to prepare solid fibres. The physicochemical effects of the coagulation bath concentration on composition, morphology, water adsorption, linear density, tensile strength and crystallinity of the prepared fibres were systematically studied by means of Scanning Electron Microscope, Wide angle X-ray scattering, adsorption test and tensile strength test. The results demonstrated that the increase in the coagulation bath concentration of sodium hydroxide resulted in greater fibre's tensile strength, greater water adsorption and greater morphological smoothness of the fibre's surface.*

Keywords: *Chitosan, Wet spinning, Coagulation bath, Chitosan fibres.*

1. Introduction

Chitin is the most abundant amino-polysaccharide polymer occurring in nature, from chitin, chitosan can be chemically synthesized via alkaline deacetylation. Chitosan is well known for its biocompatibility properties, biodegradability properties, wound-healing and antibacterial properties. All these properties make the chitosan so interesting and, however, it has not been fully studied, it is currently used in several fields including the textile industry, biotechnology, the cosmetics industry, agriculture, medical fields and the food industry. In the textile industry, there is a wide range of possible uses for chitosan, one of these is the formation of chitosan fibres by wet spinning.

The wet spinning process is used for polymers that need to be dissolved in a solvent to be spun. The spinneret is submerged in a nonsolvent chemical coagulation bath that causes the fibres to precipitate and then solidify [1]. Usually, a wide investigation in this process should be conducted. Factors such as the influence of spun ratio, composition, and concentration of coagulation bath, composition and concentration of stretching bath, stretching ratio, the temperature of stretching, as well as the composition of the rinse bath are studied. Factors mentioned above have a direct influence on the final fibre properties. Compared with melt method fibre spinning, wet spinning method has great advantages. These advantages can include, the low temperature required for fibre forming, the process can be conducted usually at room temperature which for macromolecules orientation is favourable. By wet spinning method, fibres from non-thermoplastic polymers can be produced, increasing widely the options to develop fibre from different components, with this method is also possible to control the roughness of fibres surface as well as morphology.

In recent years, the formation of chitosan fibres has been studied extensively by several researchers trying to define the suitable conditions to produce pure chitosan fibres. Apart from that, great efforts have also been made to improve its mechanical properties, one of these efforts includes the combination of chitosan with different polymers to get to know which combination is the most appropriate, the pure fibre of chitosan can be mixed with other polymers and to produce durable fabrics, yarns and materials for use in the medical field as well as in daily use. Examples of these mixtures would be chitosan-alginate, chitosan-cellulose, chitosan-nylon and chitosan-polyvinyl alcohol, just to mention a few. Chitosan fibres can be produced in different aqueous alkaline media such as NaOH, KOH, NaOH-40% methanol, or a NaOH-Na₂SO₄ / AcONa mixture [2]. Also a wide variety of functional additives can be introduced to the spinning solution, notably carbon nanotubes (CNT), nanosilver, nanoparticles of calcium phosphate or other protein polymers like fibroin, keratin or collagen [3]. The aim of this work was to present an examination of the impact that different concentrations of NaOH as a coagulation bath have on the mechanical properties of the chitosan fibre.

2. Experiment

For the development of the chitosan fibres by wet spinning, it was used a custom made spinning machine with 3 wet-medium phases and a dosing piston automatically controlled.

The chitosan fibres were obtained by preparing a polymer solution of 750 g containing chitosan at 6 wt %, the solution was prepared by adding 45 g of chitosan powder + 705 g of solvent [the solvent was prepared in the following proportions: 90 wt % deionized water (H₂O), 5 wt % Acetic Acid (CH₃COOH) and 5 wt % Urea (CH₄N₂O)]. After preparation it was mechanically stirred for 5 hours at room temperature., then the chitosan solution was poured into the dosing piston; the dosing piston was programmed to inject a constant volume of chitosan solution per minute; the injected solution went through a 500 orifices spinneret; the solution was being injected through the spinneret at the same time that it was released into the coagulation bath, a few seconds later ,after the formation of the fibres, they were carried manually to the first set of driven rollers, to subsequently, being guided to the stretching bath and after this, to the second set of driven rollers, to being carried to the rinse bath containing pure ethanol, later the fibres went through the last set of driven rollers to finally being collected in bobbins.

The next diagram shows the phases of the spinning process.

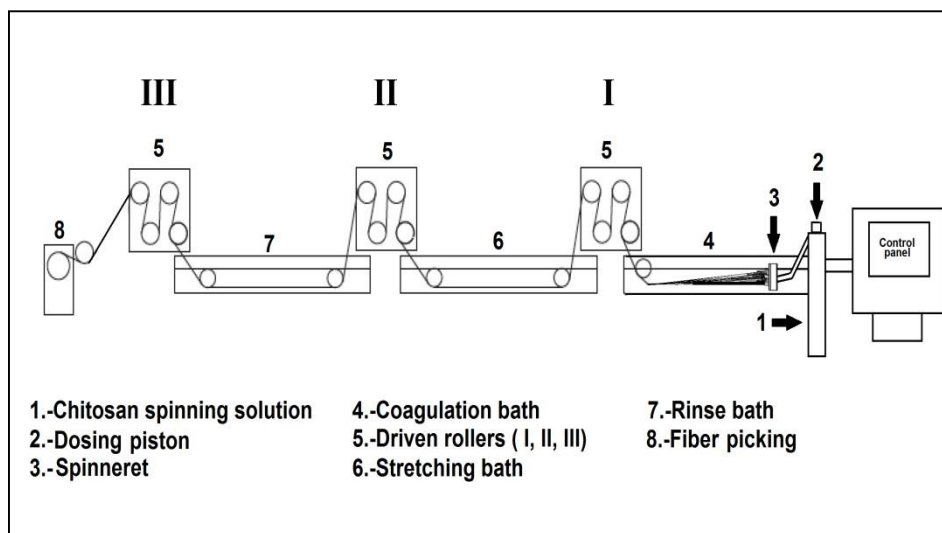

Figure 1: Custom made spinning machine.

2.1 Reagents

Chitosan powder commercial product of Sigma-Aldrich; molecular weight 60 kDa; degree of deacetylation (DDA) 96%

- deionized water
- powder urea (CH₄N₂O) ACS, Reag. Ph Eur, commercial product of Sigma-Aldrich
- acetic acid (CH₃COOH) 99% pure degree commercial product of Poch Poland
- sodium hydroxide (NaOH) analytically pure Commercial product of Poch, Poland
- sodium carbonate (Na₂CO₃) analytically pure Commercial product of Poch, Poland
- ethanol (CH₃CH₂OH) 96% pure commercial product of Polmos Kutno.

2.2 Batches of chitosan fibres

It was decided to make eleven batches of fibres with solution of chitosan at 6% of concentration and different coagulation bath concentrations of Sodium Hydroxide (NaOH) such as 1%, 2%, 4% and 5%.

The identification number given to each batch is shown in the next table:

Table 1: Fibre batches nomenclature

Fibre batches nomenclature		
Sample Identification	Number of sample	Concentration of NaOH in the coagulation bath (%)
1.1	1	1
2.1	2	
1.2	1	2
2.2	2	
3.2	3	
1.4	1	4

2.4	2	5
3.4	3	
1.5	1	
2.5	2	
3.5	3	

2.3 Spinning parameters

For the coagulation bath of the first batch of fibres, 10,000 cm³ of solution was prepared at 1% of concentration of sodium hydroxide (NaOH).

The second bath (stretching bath) was also prepared with 10,000 cm³ of solution, in this case at 0,5% of concentration of Sodium Hydroxide (NaOH), and at the end the third bath (rinse bath) was prepared with 10,000 cm³ of Ethanol (CH₃CH₂OH).

For the other batches of fibres, the procedure carried was the same, the only factor that changed was the coagulation bath's Sodium Hydroxide (NaOH) concentration, which for the second batch was 2%, for the third batch was 4% and for the fourth batch was 5%. The parameters during the wet spinning process are shown in the following table:

Table 2: Spinning process parameters

Spinning process parameters									
Sample ID	Dosing piston's speed (cm ³ /min)	Chitosan solution temp. (°C)	Coagulation bath		Driven rollers' speed I (m/min)	Stretching bath temp. (°C)	Driven rollers' speed II (m/min)	Rinse bath temp. (°C)	Driven rollers' speed III (m/min)
			Temp. (°C)	pH					
1.1	5.0	21.0	39.8	13.1	2.0	40.0	2.5	20.0	2.6
2.1	5.0	21.0	39.9	12.9	2.6	40.0	3.0	20.0	3.1
1.2	5.0	22.0	38.7	12.9	2.0	40.2	2.5	20.4	2.6
2.2	5.0	22.0	38.3	12.9	2.5	40.3	3.1	20.6	3.2
3.2	5.0	22.0	38.1	12.8	3.0	40.0	3.8	19.3	3.9
1.4	5.0	22.0	41.9	12.9	2.0	40.0	2.5	20.0	2.6
2.4	5.0	22.0	40.2	12.8	2.5	40.0	3.1	19.0	3.2
3.4	5.0	22.0	39.5	12.9	3.0	40.0	3.6	19.0	3.7
1.5	5.0	22.0	40.2	13.7	2.0	40.0	2.5	20.0	2.6
2.5	5.0	22.0	39.9	12.9	2.5	40.0	2.9	20.0	3.0
3.5	5.0	22.0	41.1	13.0	2.8	40.0	3.1	19.0	3.2

3. Characterization of Fibres

3.1 Scanning Electron Microscopy (SEM)

The surface structure of the obtained fibres was analysed using microphotography obtained by means of the Scanning electron microscope, model Nova Nanosem 230 The observations were carried out under high conditions at 10 kV and different magnifications.

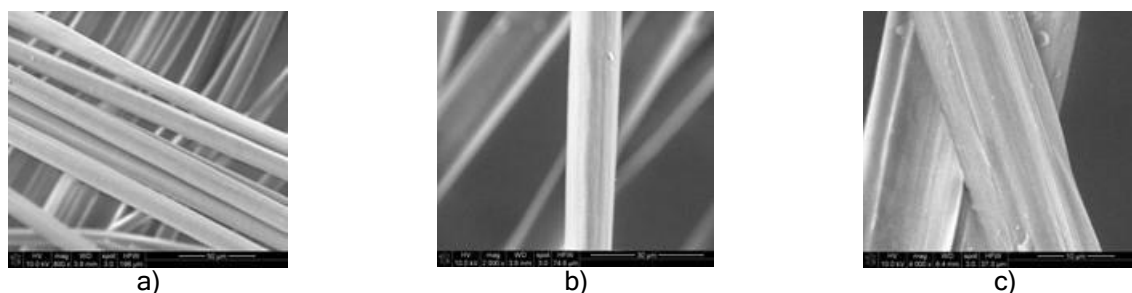

Figure 2: SEM images of Chitosan fibres obtained with a solution of 6% chitosan and 4% NaOH in the coagulation bath: a) 800x, b) 2000x and c) 4000x.

3.2 Wide Angle X-ray Scattering

This equipment was used to determine the crystallinity degree and the sizes and perfection of crystals in fibre polymers, in which diffraction patterns of X-rays scattering at 20-50° from the incident beam are recorded on film and measured. X-rays of wavelength from 0.1 to 0.3 nm are used to elucidate structural features with sizes from 0.1 to 2 nm. Crystallinity degree was analysed by X-ray diffractometer X'pert Pro to perform "WAXS" (Wide angle X-ray Scattering). Measurements were carried out in the reflection mode at room temperature. Samples were cut in small pieces in order to avoid the effect of orientation; the samples had the shape of circular plates with a radius of 1 cm and a thickness of 1 mm.

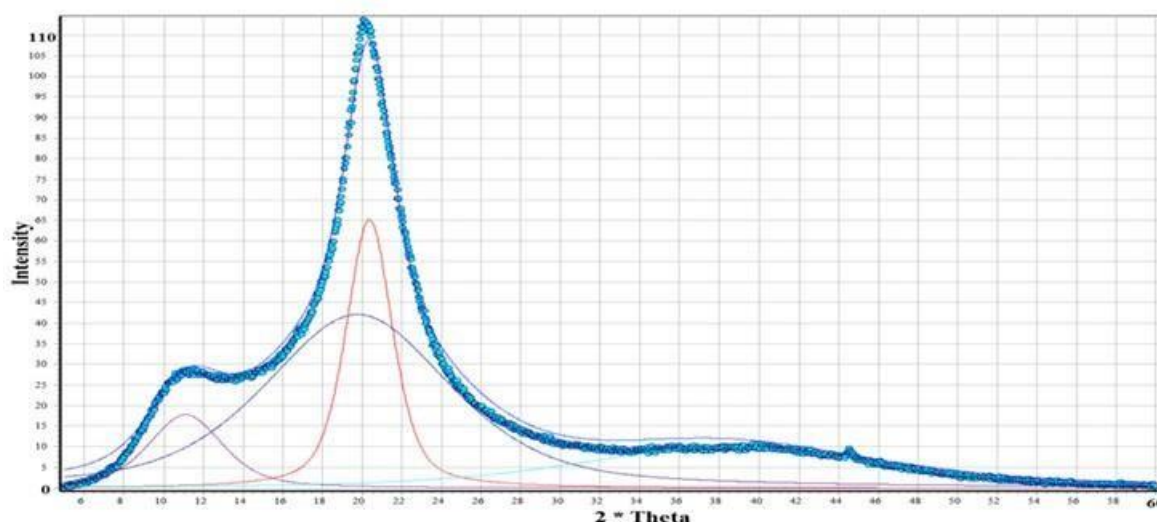

Figure 3: Sample ID 1.4, WAXS curve resolved into crystalline peaks (red curve) and amorphous (blue, thin curve) components. On the graphic plot it can be observed that the Chitosan's characteristic crystalline peaks at maximum are located at $2\theta=21^\circ$ and amorphous halos from chitosan are present from $2\theta=0^\circ$ to 40° .

3.3 Determination of linear density of chitosan fibres

This procedure was performed taking as reference the ASTM D 1059 – 01 Standard Test Method for Yarn Number Based on Short-Length Specimens [4].

Specimens of yarn of 1 m long were cut and later they were weighed in an analytical balance separately. The linear density was calculated from the mass and the measured length of the yarn.

3.4 Water Adsorption of chitosan fibre test

The amount of water adsorbed by a material was measured and expressed as a weight percent of the test specimen. Samples were cut and weighed separately at room temperature, their initial weight was recorded, after this process, the samples were located at 22°C in a controlled chamber at 100 % of relative humidity, the samples were left in the chamber for 24 hours and later their final weight was recorded and the percentage of water adsorption was calculated.

3.5 Tensile strength test

This test was performed taking as a reference the International Standard ISO 2062:2009; Textiles — Yarns from packages — Determination of single-end breaking force and elongation at break using constant rate of extension (CRE) tester. This standard specifies methods using constant rate of specimen extension (CRE) tensile testers. Testing on the now obsolete constant rate of travel (CRT) and constant rate of loading (CRL) instruments is covered [5]. The test was performed at 20 °C of temperature and 61,5% of relative humidity. The test sample length was 100,00 mm. All the test and calculations were performed with Tensile testing machine Instron 5944.

4. Results

Table 3: Results

Results				
Sample ID	Specific strength at maximum force (cN/tex)	Degree of crystallinity (%)**	Linear density (tex)	Humidity adsorption at 100% R.H. (%)
1.1	*	31.71	107,5	38.32
2.1	*	32.67	104	33.56
1.2	8,82	30.40	122	36.34
2.2	9,09	30.56	104	36.74
3.2	8,95	33.27	71,5	39.86
1.4	12,23	40.36	106,5	43.43
2.4	12,04	33.82	97	42.12
3.4	11,48	33.67	94	30.56
1.5	12,93	37.91	128	54.90
2.5	13,95	31.31	104	70.87
3.5	12,11	26.73	101	61.56

*This samples couldn't be tested because the fibres were stuck together, this was not favorable to obtain the test specimens.

**The degree of crystallinity and the diffraction curves were calculated automatically and analyzed by means of the computer program WAXSFIT [6].

5. Conclusions

After the tests performed to the chitosan fibres the following conclusions are given:

1. A wet spinning method to produce solid chitosan fibres coagulated by NaOH was introduced in the presented work.
2. The results showed that with a polymeric solution of 6% concentration of chitosan, a coagulation bath containing sodium hydroxide, a stretching bath with a lower concentration of sodium hydroxide and a rinse bath containing ethanol, chitosan fibres can be produced and characterised by tenacity of up to 13.95 cN/tex
3. The absorption properties shown to be improvement by the increment of the NaOH concentration, a maximum value of 70.87% of water absorption was recorded.
4. A very smooth surface was obtained with a solution of 6% chitosan and 4% NaOH in the coagulation bath.
5. Our findings demonstrate that the effects on the variation of all these factors can make an important difference as they have a direct influence on the physicochemical properties of the chitosan fibres. Additionally the increase of the concentration of sodium hydroxide in the coagulation bath results in greater adsorption properties, greater tenacity properties and more smoothness in the morphological surface of the fibres. The batches of fibres that showed the best physico-mechanical properties were the batches prepared with the highest concentration of sodium hydroxide in the coagulation bath.

References

- [1] Manufacturing: Synthetic and Cellulosic Fiber Formation Technology, Available from <https://web.archive.org/web/19980526024459/http://www.fibersource.com/f-tutor/techpag.htm>
Accessed: 2020-07-07
- [2] Wawro, D.; Steplewski, W.; Dymel, M.; et al.: Antibacterial Chitosan Fibers with Content of Silver Nanoparticles, *Fibers & Textiles in Eastern Europe*, **20** (2012) 96, pp. 24-31, ISSN: 1230-3666
- [3] Pati, F.; Adhikari, B. & Dhara, S.: Development of Ultrafine Chitosan Fibers Through Modified Wetspinning Technique, *Journal of Applied Polymer Science*, **121** (2011) 3, pp. 1550-1557, ISSN: 1097-4628
- [4] ASTM D 1059-01: Standard Test Method for Yarn Number Based on Short-Length Specimens.
- [5] ISO 2062:2009: Textiles - Yarns from packages - Determination of single-end breaking force and elongation at break using constant rate of extension (CRE) tester.
- [6] Rabiej, M. & Rabiej, S.: *Analiza rentgenowskich krzywych dyfrakcyjnych polimerów za pomocą programu komputerowego WAXSFIT*, Wydawnictwo ATH, ISBN: 8389086395, Bielsko-Biała, (2006)

Authors:

M. Eng. César Israel Hernández Vázquez (corresponding author); Prof. Dr Eng Zbigniew DRACZYŃSKI
Lodz University of Technology, Institute of Material Science of Textiles and Polymer Composites
Żeromskiego 116, 90-924 Łódź, Poland
Phone: +48 042 631 33 17

E-mail: cesar.hernandez.1@dokt.p.lodz.pl
E-mail: grzegorz.szparaga@p.lodz.pl
E-mail: zbigniew.draczyński@p.lodz.pl

ASSESSMENT OF THE DEGREE OF ATTACHMENT OF ACID GROUPS TO CHITOSAN FIBERS

Dominik SIKORSKI & Zbigniew DRACZYŃSKI

Abstract: Chitin and chitosan modification products are one of the main directions of research on biodegradable polymers conducted in the team of the Institute of Textile Materials and Polymer Composites of the Lodz University of Technology. The purpose of this work was to produce and perform physicochemical characterization of chitosan salts as derivatives of formic acid, acetic acid, propionic acid. The implementation of this goal can be used for obtaining chitosan salts in the form of fibers without exposing them to the process of dissolving in water during the formation of the appropriate acid salt. A new, more accurate method was then developed to determine the degree of deacetylation of chitosan using alkacimetric analysis. The physical and chemical properties as well as the rate of chitosan degradation processes depend on the degree of deacetylation and the molecular weight of this polymer. Analysis of the chemical composition of the derivatives obtained confirmed that there is a relationship between the salt formation rate and the chemical structure of organic acid.

Keywords: chitosan, deacetylation, fibres, acetic groups

1. Introduction

Chitin - one of the most common polysaccharide in the natural environment. It can be found in marine invertebrate shells, insects and fungi [1,2]. It was isolated from mushrooms in 1811 by H. Braconnot, and its structure was described by A. Hofmann in 1930 [3]. Chitosan is a biopolymer, which is a derivative of chitin, widely available in various forms in various industries. Obtained by chemical or enzymatic deacetylation [4]. There is a difference between chitin and chitosan in the degree of deacetylation [5]. From chitosan it is possible to create a variety of forms with various structures such as membranes and sponges [6,7]. Considering the use of chitosan in various materials, the greatest threat to it is biodegradation, ultrasound degradation, thermal degradation and photodegradation[8-12].

The aim of the work was to develop and carry out physicochemical characterization of chitosan salts as derivatives of formic acid, acetic acid, propionic acid. The implementation of this goal can be used to obtain chitosan salts in the form of fibers without exposing them to the process of dissolving in water while forming the corresponding acid salt. No one has performed research with such method to obtain chitosan nonwovens, which are salts of organic acids, impossible to obtain by other techniques. They may differ in their biological properties in their later applications as dressings. A new, more accurate method was then developed to determine the degree of deacetylation of chitosan by means of alkacimetric analysis.

2. Materials and methods

Chitosan fibers were produced in the laboratory scale stand at Institute. The non-woven fabric was produced by a classic non-woven technique in which the webs were formed from staple fibers (60 mm length, 2 dtex) of biodegradable chitosan using a carding system. The final nonwoven fabric was obtained by joining five layers of elementary webs. Elementary fleece was assembled to obtain a surface mass of 150 g / m².

Organic acid solutions for analysis were used in the form of ready-made solutions obtained from the manufacturer, POCh Poland.

The procedure for modification of chitosan fibers was as follows. A 10 g sample of the nonwoven fabric was placed in a 3 dm³ desiccator, in which there was an evaporator containing 10 cm³ of the appropriate acid. After 15 min, 60 min, 120 min, the nonwoven fabric sample was removed from the atmosphere of the appropriate acid and degassed under reduced pressure.

The chemical structure of chitosan after the reaction was checked by Fourier Transform Infrared - Attenuated Total Reflectance (FTIR-ATR) spectroscopy. The number of acid groups attached was determined by inverse conductometric titration.

3. Results and discussion

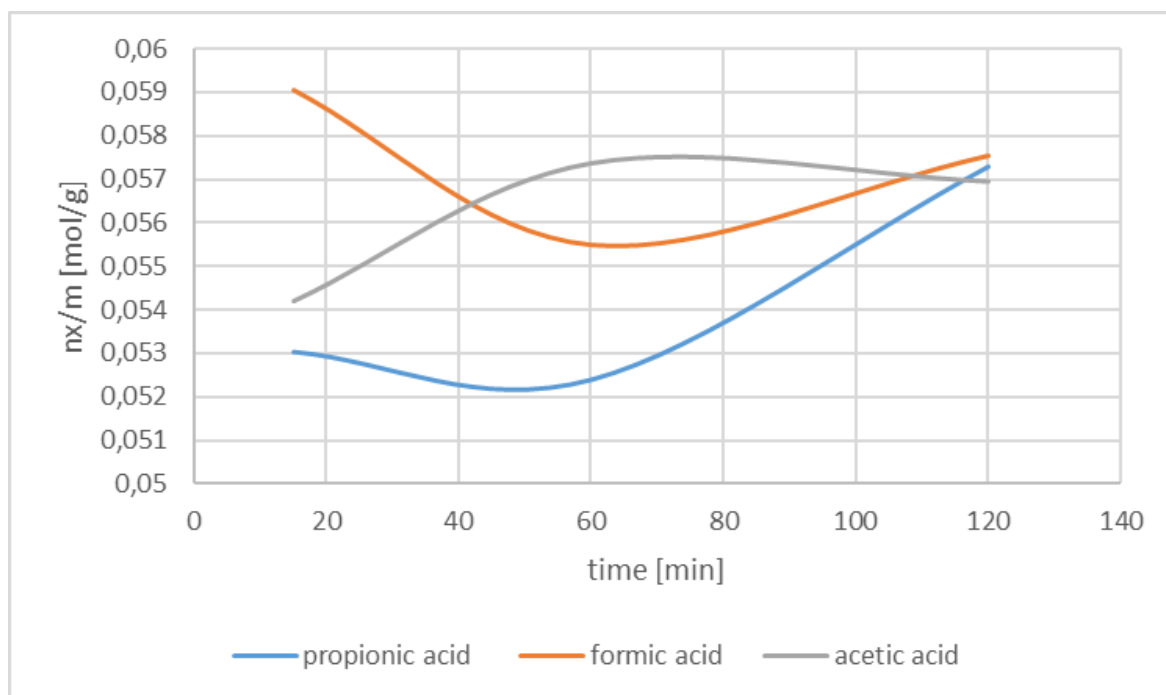

Figure 1. Concentration of acid groups at surface of fibres

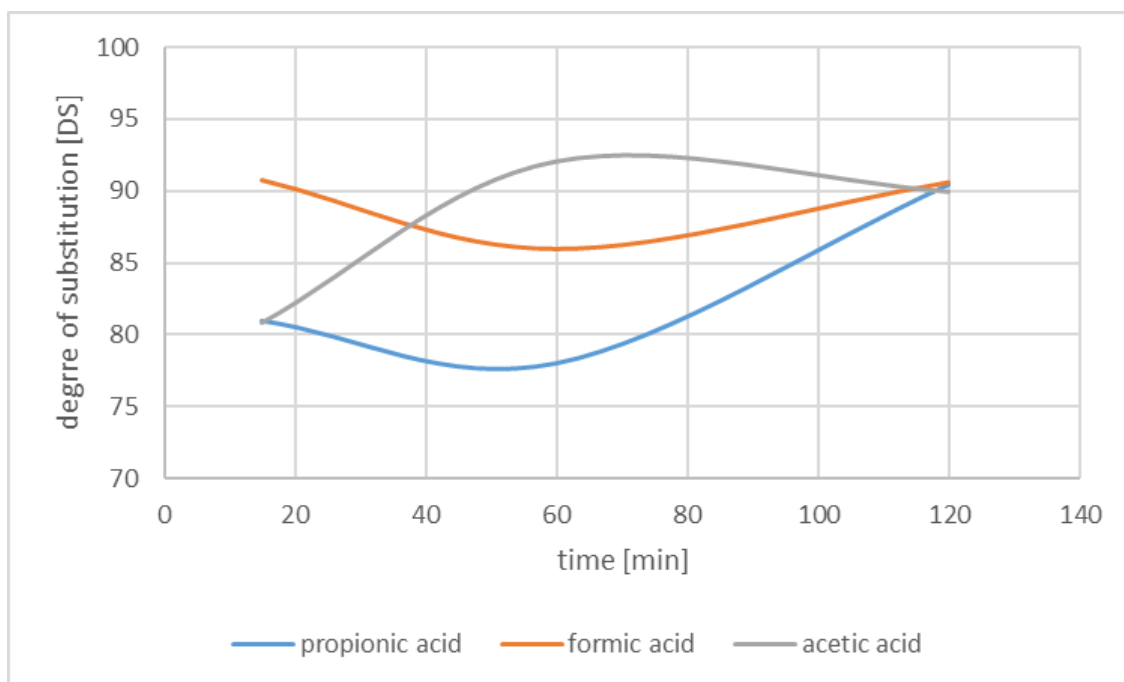

Figure 2. Calculated degree of substitution of NH₂ groups

The organic acids used in the test were selected for their good volatility and the presence of carboxyl groups that can be attach to the reactive groups in chitosan chains. They are allowed to come into contact with the human body, their presence does not cause any pathological changes, they are decomposed by enzymes and are metabolized in the organism. The calculated molar concentration allows calculating the degree of substitution of the acid groups for the active chitosan NH₂ group. From the results obtained, the degree of substitution of carboxylic molecules derived from organic acids into the functional group in the chitosan molecule was additionally counted. Thanks to this, amount of available NH₂ groups in fiber material oscillates up to 90%. The graphs show that formic acid settles the fastest on the surface of the nonwoven fabric at the beginning and disappears later. It is probably related to the condensation of acid on the nonwoven fabric and

reevaporation of the excess. For acetic acid and propionic acid, the changes took place gradually until fully attached to the structure. changes in the degree of attachment of acid groups as a function of time may be related to the structure of a specific acid. This means that after a period of 120 min, the functional groups inside the fiber are completely saturated. Through this operation, the deacetylation degree of chitosan can be determined. The method allows for more accurate extravasation of the degree of conversion that coincides with the degree of deacetylated nonwoven fabric.

4. Conclusion

The method of conducting the reaction of forming salts of chitosan and organic acid such as formic, acetic and propionic can be carried out in a heterogeneous gas-solid system. After about 120 min, a maximum conversion rate of 90% was obtained for the organic acids used in the gas phase. Using the inverse conductometric titration method, the degree of deacetylation of the chitosan can be indirectly calculated.

Acknowledgment

This work was partially supported by statutory research fund of the Institute of Material Science of Textiles and Polymer Composites no. I-42/501/4-42-1-3

References

- [1] Tylińczak B.: Animal-derived chitosans. Characteristics, comparison, application. *Przem Chem* 2016, No.,1 pp.205-8, 0033-2496
- [2] Filipe C, Jo C, Silva JC.: Chitin-Based Nanocomposites : Biomedical Applications, *Eco - friendly Polymer Nanocomposites*, Springer, India, 978-81-322-2472-3, 2016, pp.439-57
- [3] Khoushab F, Yamabhai M.: Chitin research revisited, *Mar Drugs* 2010, No.,8 pp. 1988-2012, 1660-3397
- [4] Venkatesan J, Kim SK.: Chitosan composites for bone tissue engineering - An overview. *Mar Drugs* 2010, No., 8 pp.2252-66, 1660-3397
- [5] Roy JC, Salaün F, Giraud S, Ferri A, Chen G, Guan J. Solubility of Chitin: Solvents, Solution Behaviors and Their Related Mechanisms. *Solubility of Polysaccharides*, Intechopen,2017, 1729-8814
- [6] Madhumathi K, Shalumon KT, Rani VVD, Tamura H, Furuike T, Selvamurugan N, et al.: Wet chemical synthesis of chitosan hydrogel-hydroxyapatite composite membranes for tissue engineering applications. *Int J Biol Macromol*, 2009, No., 45 pp.12-5, 0141-8130
- [7] Jayakumar R, Prabakaran M, Nair S V., Tamura H.: Novel chitin and chitosan nanofibers in biomedical applications. *Biotechnol Adv*, 2010, No.,28 pp.142-50, 0734-9750
- [8] Ma Z, Wang W, Wu Y, He Y, Wu T.: Oxidative degradation of chitosan to the low molecular water-soluble chitosan over peroxotungstate as chemical scissors. *PLoS One*, 2014, No., 9 pp.3-9, e100743
- [9] Martini B, Dimida S, De Benedetto E, Madaghiele M, Demitri C.: Study on the degradation of chitosan slurries. *Results Phys*, 2016 No., 6 pp.728-9, 2211-3797
- [10] Gámiz-González MA, Correia DM, Lanceros-Mendez S, Sencadas V, Gómez Ribelles JL, Vidaurre A.: Kinetic study of thermal degradation of chitosan as a function of deacetylation degree. *Carbohydr Polym* 2017, No.,167 pp. 52-8, 1879-1344.
- [11] Czechowska-Biskup R, Rokita B, Lotfy S, Ulanski P, Rosiak JM.: Degradation of chitosan and starch by 360-kHz ultrasound. *Carbohydr Polym* 2005, No., 60 pp.175-84, 1879-1344.
- [12] Bajer D, Kaczmarek H.: Study of the Influence OV UV Radiation on Biodegradable Blends Based on Chitosan and Starch. *Prog Chem Appl Chitin Its Deriv*, 2010, No.,15 pp.17-24,1896-5644.

Authors:

Msc Eng Dominik Sikorski (corresponding author), Prof. Dr Eng Zbigniew Draczyński
Lodz University of Technology, Institute of Textile Materials and Polymer Composites
Żeromskiego 116 90-924, Łódź, Poland
Phone: +48 042 631-33-17

E-mail: zbigniew.draczyński@p.lodz.pl
E-mail: dominik.sikorski@dokt.p.lodz.pl

THE INFLUENCE PHYSICO-CHEMICAL PROPERTIES OF ANTI-REDEPOSITION AGENTS ON THE ZETA POTENTIAL OF WASHED COTTON FABRICS

Ksenija VIŠIĆ & Tanja PUŠIĆ

Abstract: Research in the doctoral thesis includes special additives, anti-redeposition agents (ARA), in the formulation of powder detergent. Various ARA have been selected, and for these purposes carboxymethyl cellulose (CMC) and carboxymethyl starch (CMS) will be presented, the concentration of which is adjusted to washing of cellulose materials at 40 °C, 60 °C and 90 °C. These inhibitors were added to powder detergent and analyzed by washing in hard water. Characterization of standard cotton fabrics after 10 washing cycles with respect to the unwashed ones was made by analyzing the zeta potential of the washed materials and the content of incrustations.

Keywords: detergents, washing, anti-redeposition agents, carboxymethyl cellulose, cellulose materials

1. Introduction

The development of detergents is based on technological guidelines, whereby it is necessary to make a formulation in which all the components act in synergy with the factors of the Sinner's circle: temperature, mechanical action, and washing time [1]. Recently, environmentally friendly low temperature processes in small bath ratios have been promoted, which, according to the Sinner's circle, require high-performance surfactants, builders, bleaching agents and their activators, enzymes and special polymers in detergents. Surfactants and builders cannot completely retain dirt in the bath, allowing dirt to settle on the surface of the material, causing graying. It is difficult to remove them afterwards, even using multiple cycles, especially if dirt particles are very fine. In order to prevent this phenomenon, special polymers are added to detergents, which, with appropriate surfactants and builders, can inhibit the graying of white cotton materials in multiple washing cycles.

In order for ARAs to be effective, it must be related to the fibers properties to be washed, to be temporarily bonded, to increase the negative charge of the fiber surface, to repel the negative charged soil or pigment particles and to prevent redeposition. Classic ARAs are certain cellulose derivatives of which the best known is sodium carboxymethyl cellulose (CMC). The number of hydroxyl groups replaced by carboxymethyl groups per unit glucose is defined as the degree of substitution (DS). CMC properties depend on DS and distribution of substitution in glucose units and throughout the cellulose chain [2]. It was first introduced into the detergent composition in 1940. It is biodegradable, and its degradation rate is inversely proportional to DS [3-6]. This paper is focused on the ARA, carboxymethyl cellulose (CMC) and carboxymethyl starch (CMS) added to a detergent for washing standard cotton fabric through 10 cycles in hard water.

2. Methods

For the purpose of the presentation of this PhD thesis, the gravimetric method and the method of streaming potential were selected. Surface of the unwashed and 10 times washed cotton fabric with the detergent in concentration 5 g/l containing CMC and CMS in a concentration of 0.4% was analyzed. Figure 1 shows the chemical structures of the analysed ARAs.

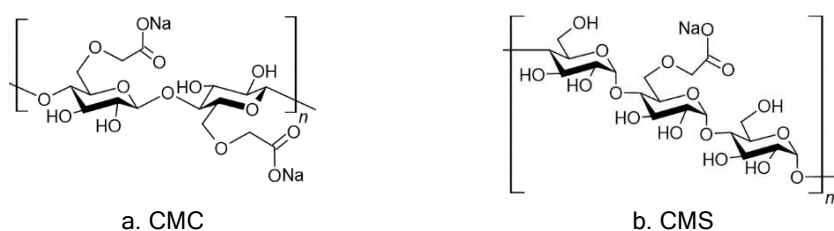

Figure 1: Chemical structure: a. carboxymethyl cellulose (CMC) [7], b. carboxymethyl starch (CMS) [8]

The standard cotton fabrics have been washed in a laboratory conditions (P_PT) with detergent in hard water (T) characterized by hardness of 398 ppm CaCO₃ at different temperatures: 40°C, 60°C and 90°C [9].

The content of inorganic incrustations was examined gravimetrically after incineration of the unwashed and 10 cycles washed standard cotton fabrics under the above-mentioned conditions.

The surface of the cotton materials in the defined washing conditions was evaluated by the method of streaming potential in the Electrokinetic Analyzer, Anton Paar GmbH. Hydrodynamic liquid streaming causes charge redistribution on the surface of the material, and streaming potential (Up) is generated.

The surface is rough and the resistance inside the measuring cell is also measured, and the zeta potential is calculated according to the Helmholtz-Smoluchowski equation [10, 11].

3. Results and discussion

Considering the mechanism of action of ARAs in washing at different temperatures, it is useful to analyze the surface of the unwashed and 10 cycles washed standard cotton fabric. The detergent contains a builder, whose role is to soften the water during washing and to prevent the deposition of inorganic compounds on the surface of the cotton material. In addition, the extent to which the precipitation of inorganic incrustations occurred during washing must be analyzed, taking into account the variation in washing temperatures. The results of the ash content (A) after incineration the three samples of unwashed and 10 cycles washed standard cotton fabric at 40 °C, 60 °C and 90 °C with statistical indicators are shown in Table 1.

Table 1: Ash content on the unwashed (PT) and through 10 cycles washed standard cotton fabric using the detergent with the addition of CMC and CMS at 40 °C, 60 °C and 90 °C in hard water

Sample	A [%]	\bar{x}	σ	CV [%]
PT	0.2	0.213	0.0051	2.38
P_PT_CMC_40_T_10X	1.2	1.176	0.0581	4.94
P_PT_CMC_60_T_10X	1.1	1.102	0.0305	2.76
P_PT_CMC_90_T_10X	1.2	1.241	0.0376	3.03
P_PT_CMS_40_T_10X	0.6	0.591	0.0037	0.63
P_PT_CMS_60_T_10X	0.7	0.668	0.0089	1.33
P_PT_CMS_90_T_10X	2.0	2.038	0.0215	1.05

\bar{x} - mean value, σ - standard deviation and CV - coefficient of variation

The quality control system RAL-GZ 992 prescribes the limit values for quality parameters of cotton fabrics after 25 and 50 washing cycles, one of them being ash content. The limit value of the ash content of the fabric washed through 25 washing cycles is 0.7 %, and of the fabric washed through 50 cycles is 1.0 %. The results presented in Table 1 indicate that 10 washing cycles of the standard cotton fabric with detergent with the addition of CMC in hard water increases the ash content compared to the unwashed fabric. The resulting values of the ash content of the washed fabrics at all temperatures are higher than 1.0%. A temperature rise does not have a significant effect on the ash content increase.

However, 10 washing cycles of cotton fabric with detergent with the addition of CMS at temperatures 40°C, 60°C and 90°C in hard water have a different effect. The washing temperature of 90°C caused the strongest effect, resulting in the ash content in the cotton fabric of 2.0 %. The ash content values of the fabric washed at 40°C and 60°C are lower compared to the same washing temperatures using detergent with the addition of CMC.

Figures 2 and 3 show the results of the zeta potential of the unwashed and 10 cycles washed standard cotton fabric using the detergent to which the CMC and CMS ARAs were added at 40 °C, 60 °C and 90 °C.

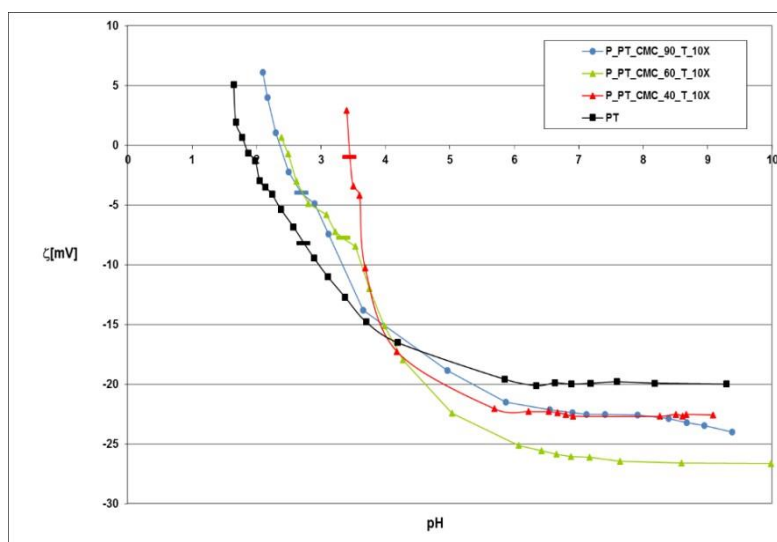

Figure 2: Zeta potential of the unwashed and 10 cycles washed standard cotton fabric using the detergent with the addition of CMC in hard water at temperatures of 40 °C, 60 °C and 90 °C depending on pH

The results of the zeta potential of the unwashed and 10 cycles washed cotton fabrics at different temperatures in hard water depending on the pH of the electrolyte solution indicate their mutual differences, Figure 2. The unwashed cotton fabric was pre-bleached, and the resulting zeta potential curve as a function of pH is typical for this state of materials, with improved hydrophilic properties. Washing the cotton fabric through 10 cycles with detergent with the addition of CMC at all temperatures effected change in the surface of the cotton fabric throughout the pH range. In the pH range from 10 to pH 4 the washed cotton fabrics had a more negative charge than the unwashed ones, implying an increased number of carboxyl groups (-COOH) through orientation of the CMC through 10 cycles. Based on this, it can be concluded that inorganic incrustations under the tested conditions did not prevent orientation and increase in the surface charge of the washed fabric.

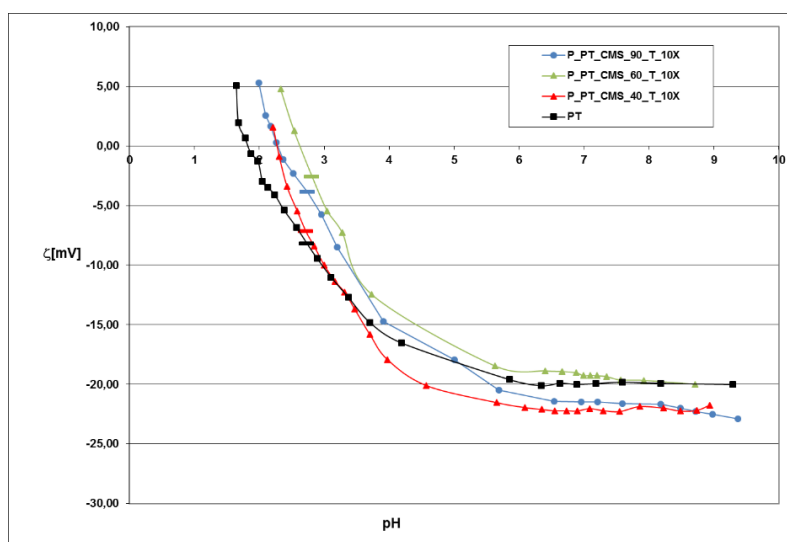

Figure 3: Zeta potential of the unwashed and through 10 cycles washed standard cotton fabric using the detergent with the addition of CMS in hard water and at temperatures of 40 °C, 60 °C and 90 °C in hard water depending on pH

Washing cotton fabrics through 10 wash cycles with detergent with the addition of CMS at all temperatures also effected change in the surface of the cotton fabric within the whole pH range. The changes are smaller compared to washing with the detergent with the addition of CMC. In the pH range from 10 to pH 3.5 the cotton fabrics washed at 40 °C and 90 °C had a more negative charge than the unwashed one, implying an increased number of carboxyl groups (-COOH) through orientation of the CMS through 10 cycles. Based on this, it can be concluded that inorganic incrustations under the tested conditions did not prevent orientation and increase in the surface charge of the washed fabric. However, the surface state of the fabric washed at 60 °C indicates a less negative zeta potential compared to the unwashed fabric. On this basis, it can be concluded that in this

case inorganic incrustations prevented the orientation of the CMS and increase in surface charge. Comparison of Figures 2 and 3 indicates the predominant influence of CMC over CMS on an increase in the negative charge of the cotton fabric washed through 10 cycles in hard water.

4. Conclusion

Carboxymethyl cellulose and carboxymethyl starch as anti-redeposition agents added to the detergent for washing of standard cotton fabric in hard water show a specific action because they increase zeta potential. The resulting differences in the characterization of the surface charge of the standard cotton fabric washed through 10 cycles in hard water indicate a better effect of CMC compared to CMS. Analysis of the ash content indicates the presence of inorganic incrustations, which, despite their high values, did not prevent the orientation of the analyzed ARAs on the surface of the cotton fabric. It indicates on different mechanisms in orientation and saturation of a cotton fabric surface with anti-redeposition agents and inorganic matters from washing bath.

References

- [1] Smulders, E.; Krings, P. & Verbeek, H.: Recent developments in the field of laundry detergents and cleaners, *Tenside Surfactants Detergents*, **34** (1997) No.6, pp. 386-392, ISSN: 0932-3414
- [2] Gu, H. et al.: Water soluble carboxymethylcellulose fibers derived from alkalization-ethetification of viscose fibers, *Fibers and Polymers*, **13** (2012) No.6, pp. 748-753, ISSN: 1229-9197
- [3] Batelaan, J. G.; van Ginkel, C.G. & Balk, F.: Carboxymethylcellulose (CMC), *Detergents, Anthropogenic Compounds*, Vol. (3/3F) ISBN: 978-3-662-14983-6, Berlin (1992) pp. 320-336
- [4] Vaughn, T. H. et.al.: The effect of sodium carboxymethyl cellulose on synthetic detergent systems, *Journal of the American Oil Chemists' Society*, **25** (1948) No. 2, pp. 44-51, ISSN: 1558-9331
- [5] Smulders, E.: *Laundry detergents*, Wiley-VCH Verlag GmbH & Co. KGaA, 2002, ISBN: 9783527305209
- [6] Soljačić, I., Pušić, T.: *Njega tekstila: Čišćenje u vodenom mediju*, Sveučilište u Zagrebu Tekstilno-tehnološki fakultet Zagreb, ISBN: 9537105091, Zagreb (2005)
- [7] Available from <https://cymitquimica.com/products/3D-YC44523/9004-32-4/carboxymethyl-cellulose-sodium-viscosity-1000-1300-mpas/>, Accessed: 2020-02-23
- [8] Available from <https://sites.google.com/site/sunrayinternational/products/sodium-carboxy-methyl-starch-cms/>, Accessed: 2020-02-23
- [9] Available from <https://www.mrpltd.com/html/wfk.html/>, Accessed: 2020-02-24
- [10] Luxbacher, T., Pušić, T. & Petrinić, I.: Monitoring the washing efficiency of stained cotton fabrics by streaming potential measurement, Book of Proceeding (ITC&DC), (Dragčević, Z., Hursa Šajatović, A., Vujasinović, E.), pp. 825-830, ISSN: 1847-7275, Dubrovnik, Croatia, October 2008, University of Zagreb, Faculty of Textile Technology, Zagreb, (2008)
- [11] Pušić, T.; Višić, K. & Soljačić, I.: Surface characterization of multiple washed textiles; Book of *Proceedings of 11th World Textile Conference (AUTEX)*, (Adolphe, D.; Schacher, L.), pp. 1004-1008, ISBN: 978-2-7466-2858-8, Mulhouse, France, June 2011., Ecole Nationale Supérieure d'Ingénieurs Sud Alsace, University in Brunstatt-Didenheim, Mulhouse, (2011)

Authors :

Ksenija VIŠIĆ, B.Sc. (corresponding author)
University of Zagreb Faculty of Textile Technology
Prilaz baruna Filipovića 28a, 10 000 Zagreb, Croatia
Phone: +(385) (1) 4877 359

E-mail: ksenija.visic@tff.unizg.hr

Prof. Tanja PUŠIĆ, PhD.
University of Zagreb Faculty of Textile Technology
Prilaz baruna Filipovića 28a, 10 000 Zagreb, Croatia
Phone: +(385) (1) 4877 354

E-mail: tanja.pusic@tff.unizg.hr

IMPACT OF THE AGING PROCESS ON SODIUM ALGINATE SOLUTIONS WITH THE ADDITION OF LOW MOLECULAR WEIGHT IONIC COMPOUNDS

Nina TARZYŃSKA & Zbigniew DRACZYŃSKI

Abstract: *The addition of a small amount of compounds increasing the pH of the solution, such as Na₂CO₃ or NaOH reduces the proportion of unreacted acid groups of the commercially used solution of sodium alginate. For comparative purposes, a compound that did not change the pH of the initial solution - NaCl - was also added. The replacement of non-dissociative alginic acid groups with dissociated groups of sodium alginate reduces the apparent dynamic viscosity of the system, which allows increasing the efficiency of the process of spinning alginate fibers by the wet spinning method.*

Keywords: *sodium alginate, apparent viscosity, aging process, low molecular weight ionic compounds*

1. Introduction

Alginates are naturally occurring polysaccharide copolymers consisting of β-D-mannuronic acid (M-block) and α-L-guluronic acid (G-block) residues joined together by glycosidic linkages [1-2]. These blocks occur in different proportions and in different locations along the chain. Possible deployments are MM, GG, GM [3-5].

Alginates from seaweed stems are usually characterized by a higher content of guluron blocks, while alginates from seaweed leaves are characterized by a higher content of mannuronic blocks [6,7]. In case of guluron blocks, the stereochemical structure of two repeating structural units allows to create space and close the divalent metal ions, e.g. calcium, to form an "egg-box" structure. In this structure, it is difficult to exchange calcium ions for sodium ions and it is possible to retain water. Gels that are formed from alginate with a higher content of guluronic acid blocks are defined as hard gels [8]. However gels made of alginate with a predominance of manurone blocks are soft gels. This structure allows to absorb water between the polymer chains and simplifies the exchange of ions.

Alginate fibres can be divided into many types, due to the type of their material: alginic acid, zinc alginate, copper alginate, sodium alginate, calcium alginate, ammonium alginate [9]. However, calcium alginate or sodium-calcium alginate is the most commonly used to produce alginate fibres. The process of solidification of calcium alginate fibres results from physicochemical reactions which consist of diffusion and exchange of Na⁺ ion into bivalent Ca²⁺ ions [8]. The formation of intermolecular bonds between alginate macromolecules occurs as a result of interaction of calcium ions with the remains of guluronic acid. As the fibres solidify, the viscosity of the spinning solution stream increases, which is connected with the diffusion of sodium ions from the inside of the fibre into the solidifying bath, therefore, fragments containing sodium ions are also most often found in fibres called alginate fibres. Calcium alginate fibres are considered to be those which do not dissolve in water but only swell. Sodium calcium alginate fibres are characterised by significantly higher swelling capacity in water than fibres typically called alginate fibres, also insoluble in water.

Typically, they are spun by the wet method, from aqueous solutions at a concentration of 4 to 8% [10, 11]. Then in the coagulation bath, sodium ions are exchanged for calcium ions. The composition of this bath depends on whether the fiber produced contains alginic acid, calcium alginate or other alginate derivatives.

The addition of low-molecular-weight ionic compounds (NaCl, NaOH, Na₂CO₃) to the solution of sodium alginate may affect its dissociation and conformation. The change in dissociation constant of sodium alginate and its conformation in solution, under the influence of coexisting ions originating from low-molecular compounds, may influence the degradation process in solutions [12].

The aim of this study was to investigate the impact of the presence of compounds containing active sodium ions in sodium alginate solutions, derived from salts that differ in their susceptibility to hydrolysis, on the degradation process.

2. Materials and methods

2.1. Solutions preparation

For analysing sodium alginate solutions, 8 and 10% alginate solutions containing 0.1 M NaOH, 0.125 M NaCl and 0.025 M Na₂CO₃ were prepared. As reference samples, solutions with an analogous concentration but without the addition of low molecular weight ionic compounds were also tested.

Polymer solutions were prepared by dissolving sodium alginate in distilled water for 4 hours, using a mechanical stirrer - Heidolph RZR-1 Control.

2.2. The apparent dynamic viscosity measurements

The apparent dynamic viscosity measurements were carried out on a Fungilab OneSeries rotational viscometer at a shear rate of 1 1 / s at 25 °C. The R7 measuring spindle was used for the tests, and the measurements were performed after 1, 3 and 14 days.

2.3. Accelerated aging tests

In addition for solutions with 8% polymer concentration, accelerated aging tests at the temperature of 50 °C for 3 days were carried out.

3. Results

The value of the apparent viscosity of the solutions containing both 8 and 10% sodium alginate does not change rapidly over time, only after the accelerated aging process this value decreases rapidly. For solutions with the addition of 0.1 M NaOH, a significant decrease in viscosity can be observed with the passage of time, that means that polymer degradation occurs.

As it can be seen in table 1 the viscosity of 8% sodium alginate solutions with the addition of 0.125 M NaCl increases. The addition of ions of dissociated low molecular weight salt to alginate solutions causes a change in the conformation of the alginate macromolecules. In such solutions, alginate macromolecules reduce their volume creating more compact structures. The permeation of these structures probably results in an increase of intermolecular friction forces. This phenomenon results in an increase of apparent dynamic viscosity. Solutions with the addition of sodium carbonate remain stable over time, in comparison to unmodified solutions.

Table 1. Apparent viscosity of 8% sodium alginate solutions

time from solution preparation	Apparent viscosity at shear rate 1 / s (mPa·s)			
	8 % sodium alginate	8 % sodium alginate + 0.1 M NaOH	8 % sodium alginate + 0.125 M NaCl	8 % sodium alginate + 0.025 M Na ₂ CO ₃
1 day	84 363	45 320	115 924	36 250
3 days	67 321	19 848	110 744	27 761
14 days	74 299	7 332	484 465	34 304
Accelerated aging	49674	-	199 355	20 270

For 8 % sodium alginate solutions, the lowest changes in apparent dynamic viscosity can be observed for solutions of sodium alginate and sodium alginate with added sodium carbonate. Their viscosity drops by about 20 % after 3 days. For solutions with added sodium hydroxide, a decrease in viscosity of as much as 84 % is observed after 14 days, which proves the degradation of the solutions. Solutions with sodium chloride, on the other hand, increase their viscosity during the aging process, which may be due to the straightening of polymer macromolecules in the solution.

Spinning solutions containing 10 % sodium alginate (Table 2) have much higher apparent dynamic viscosity values than those containing 8 % polymer, which is typical for polymeric solutions. The presence of low-molecular-weight ionic compounds, with the exception of NaCl, has reduced this viscosity, making the spinning process more efficient and easier to carry out.

Table 2. Apparent viscosity of 10% sodium alginate solutions

time from solution preparation	Apparent viscosity at shear rate 1 / s (mPa·s)			
	10 % sodium alginate	10 % sodium alginate+ 0.1 M NaOH	10 % sodium alginate + 0.125 M NaCl	10 % sodium alginate + 0.025 M Na ₂ CO ₃
1	291 268	216 687	496 717	288 514
3	284 545	190 621	437 556	250 548
14	264 781	105 550	432 522	234 045

10 % sodium alginate spinning solutions are characterized by a small decrease in apparent dynamic viscosity, by only 9 % after 14 days. In all solutions of sodium alginate with the addition of low-molecular-weight ionic compounds a decrease in viscosity of about 12 % can be observed after 3 days. However, after 14 days, a large decrease in viscosity of the solution with sodium hydroxide is observed, as high as 51 %, due to degradation of the solution.

Figure 1 shows an exemplary diagram of the dependence of apparent dynamic viscosity as a function of shear rate for solutions with 8% polymer content and 0.1M NaOH during ageing process.

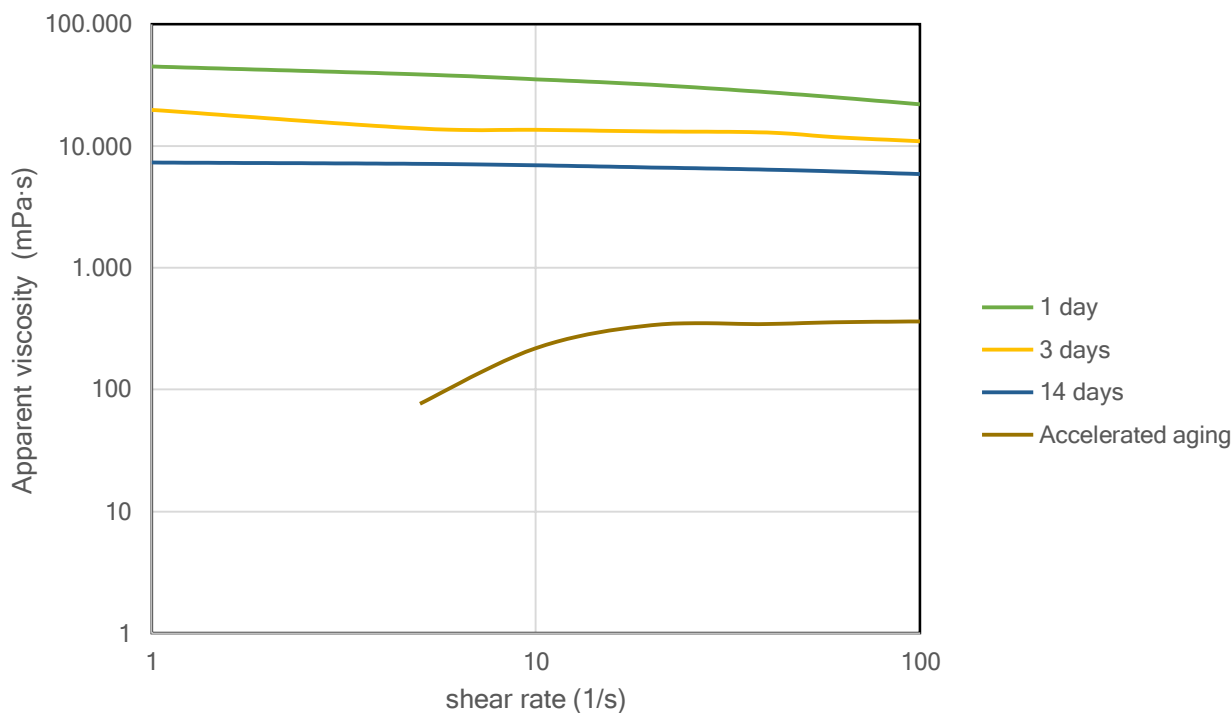

Figure 1: Shear rate dependence of apparent viscosity for an 8 % solution of sodium alginate and 0.1 M NaOH.

Most of the solutions turned out to be non-Newtonian fluids diluted by shearing. Their viscosity decreases with the increase in shear rate, but at a rate close to zero these fluids behave like Newtonian fluids of constant viscosity.

Figure 2 and Figure 3 presents photos of the solutions that have undergone the ageing process. The change of colour is visible after they are subjected to an accelerated ageing process, which may also indicate a degradation process.



8 % sodium alginate



8 % sodium alginate + 0.1 M NaOH

Figure 2: 8% sodium alginate solution and sodium alginate solution containing NaOH after accelerated aging and 16 days after manufacture.



8 % sodium alginate + 0.025 M Na₂CO₃



8 % sodium alginate + 0.125 M NaCl

Figure 3: 8% sodium alginate solutions containing Na₂CO₃ and NaCl after accelerated aging and 16 days after manufacture.

4. Conclusion

The sodium salt of alginic acid belongs to the group of polyelectrolyte compounds, therefore in polar solutions, e.g. water, the presence of additionally introduced ionic compounds affects the conformation of the macromolecule. A small addition of NaCl causes straightening of macromolecules, and results in an increase of apparent dynamic viscosity value of the obtained solutions.

By increasing the polymer concentration in the spinning solution from 8 to 10% and the addition of low molecular weight ionic compounds, it is possible to reduce the apparent dynamic viscosity of the solution, enabling the production of fibers by the wet spinning method. However, they also tend to degrade faster, which means that spinning must take place within a short period of time after preparation of the solution.

References

- [1] Wyřębska, Ł., et al: Synteza i aplikacja nowych pochodnych wybranych polisacharydów Część I: Przegląd literatury. *Technologia i Jakość Wytrobów* **59**. (2014), pp. 1-16, 2299-7989
- [2] Draget, K.I., et al: Alginates. In *Food polysaccharides and their applications*, 2 nd. ed.; Stephen, A. M; Phillips, G. O.; Williams P.A., Eds.; Taylor and Francis Group: Boca Raton, United States of America, (2006), pp. 291-295
- [3] Pegg, C., et al.: Facile preparation of ammonium alginate-derived nanofibers carrying diverse therapeutic cargo. *Chemical communications*, **50**. (2013), pp. 127-250, 1364-548X
- [4] Eiselt, P, et al.: Porous carriers for biomedical applications based on alginate hydrogels. *Biomaterials*, **21**. (2000) 19, pp. 1921-1927, 0142-9612
- [5] Fertah, M., et al: Extraction and characterization of sodium alginate from Moroccan *Laminariadigitata* brown seaweed. *Arabian Journal of Chemistry*, **10**. (2017), pp. 3707-S3714, 1878-5352
- [6] Boguń, M.: *Nanokompozytowe włókna alginianowe i kompozyty z ich udziałem do zastosowań w inżynierii biomateriałowej*. Zeszyty naukowe Politechniki Łódzkiej nr 1062, 0374-4817, Łódź, (2010)
- [7] Eichhorn, S, et al: *Handbook of Textile Fibre Structure, Volume 2 - Natural, Regenerated, Inorganic and Specialist Fibres*. Woodhead Publishing, 2050-1501, Cambridge, (2009)
- [8] Pielesz, A: *Algi i alginy – leczenie, zdrowie i uroda*. Wydawnictwo internetowe e-bookowo, (2010)
- [9] Mather, R. R., Wardman, R. H.: *Chemistry of Textile Fibres*. The Royal Society of Chemistry, (2011)
- [10] Qin, Y.: Alginate fibres: an overview of the production processes and applications in wound management. *Polymer International*, **57** (2008), pp. 171-180, 1097-0126
- [11] Xu, G, et al: Fabrication and Characterization of Alginate Fibers by Wet-Spinning. *Advanced Materials Research* **796**. (2013), pp. 87-91, 1662-8985
- [12] Mahmood, S.J., Siddique, A.: Ionic studies of sodium alginate isolated from *Sargassum terrarium* (brown alga) karachi coast with 2,1-electrolyte, *Journal of Saudi Chemical Society*, **14** (2010), 1., pp. 117-123, 1319-6103

Authors:

M. Sc, Eng Nina TARZYŃSKA (corresponding author); Prof. Dr Eng Zbigniew DRACZYŃSKI
Lodz University of Technology, Institute of Material Science of Textiles and Polymer Composites
Żeromskiego 116, 90-924 Łódź, Poland
Phone: +48 042 631 33 17

Fax: +48 042 631 33 18

E-mail: nina.tarzynska@dokt.p.lodz.pl
E-mail: zbigniew.draczyński@p.lodz.pl

ADSORPTION OF CETYLPYRIDINIUM CHLORIDE ON STANDARD POLYESTER FABRIC IN THE ELECTROKINETIC ANALYZER

Katia GRGIĆ & Tanja PUŠIĆ

Abstract: *Cationic surfactants are widely used in technological processes because of their functionality and favorable environmental effects. Quaternary ammonium compounds (QAC) are especially distinguished among them due to their antibacterial properties, low toxicity, low skin irritation, poor corrosivity and good environmental stability. The aim of this work is investigation of the adsorption of QAC, cetylpyridinium chloride, on standard woven cotton PES fabric at pH 9.0, 6.0 and 4.0 in an electrokinetic analyzer by measuring the streaming potential.*

Keywords: *adsorption, polyester fabric, cetylpyridinium chloride, streaming potential*

1. Introduction

Despite its long application, cationic surfactants play a significant role in technological processes of the 21st century. Due to functionality and favourable ecological effects they have been applied in dentistry, pharmacology, cosmetics and medicine [1,2]. Quaternary ammonium compounds (QAC) are especially distinguished among them due to their antibacterial properties, low toxicity, low skin irritation, poor corrosivity and good environmental stability. The antibacterial activity of QAC depends on their structure and the length of the hydrophobic, alkyl chain. Hydrophobic segments, chain lengths from C8 to C18, are compatible with the lipid bilayer of the bacterial cytoplasmic membrane and can be rapidly adsorbed on the negatively charged cell surface of the microorganism, resulting in the loss of cytoplasmic constituents and their destruction [3].

Cetylpyridinium chloride (CPC) is a quaternary ammonium compound of historical importance for safe and effective oral administration as an antiseptic in mouthwashes, toothpastes, nasal sprays, lozenges, cosmetics and disinfectants [4]. Some of the possible applications of CPC are based on its adsorption on different surfaces as well as desorption from surfaces. Previous research was focused on CPC adsorption on standard fabrics from cotton and polyester/cotton at pH 6.0 and pH 9.0 as well as its desorption at pH 6.0 [5].

The aim of this paper is adsorption of CPC on standard polyester fabric at pH 9.0, 6.0 and 4.0 in the SurPASS electrokinetic analyzer. After the equilibrium state is reached, desorption of CPC from PES fabric was initiated at pH 6.0 in the SurPASS. Preliminary experiments have included characterization of standard PES fabric through swelling behaviour and zeta potential curve in pH range from 9.0 to pH which correspond to the isoelectric point (IEP).

2. Experimental part

Standard polyester fabric designated as 30A supplied by WFK Testgewebe GmbH was used as adsorbent and desorbent through a research plan conducted in the electrokinetic analyzer SurPAAS produced by Anton Paar GmbH, Figure 1a.

The streaming potential of the standard polyester fabric embedded in an adjustable gap cell, AGC - was measured in variation of pH 1 mmol/L KCl solution as an electrolyte, Figure 1b [6]. Characterization of polyester fabric by streaming potential method resulted with a specific curve of zeta potential versus pH.

Analysis of polyester fabric swelling stability in the previously specified electrolyte at pH 6.0 was conducted by measurement of streaming potential versus the time.

Adsorption of CPC on the standard polyester fabric was studied in variation of three pH values, pH 9.0, pH 6.0 and pH 4.0 until equilibrium was reached. After that, desorption of CPC from polyester standard fabric was initiated until streaming potential was not stable.

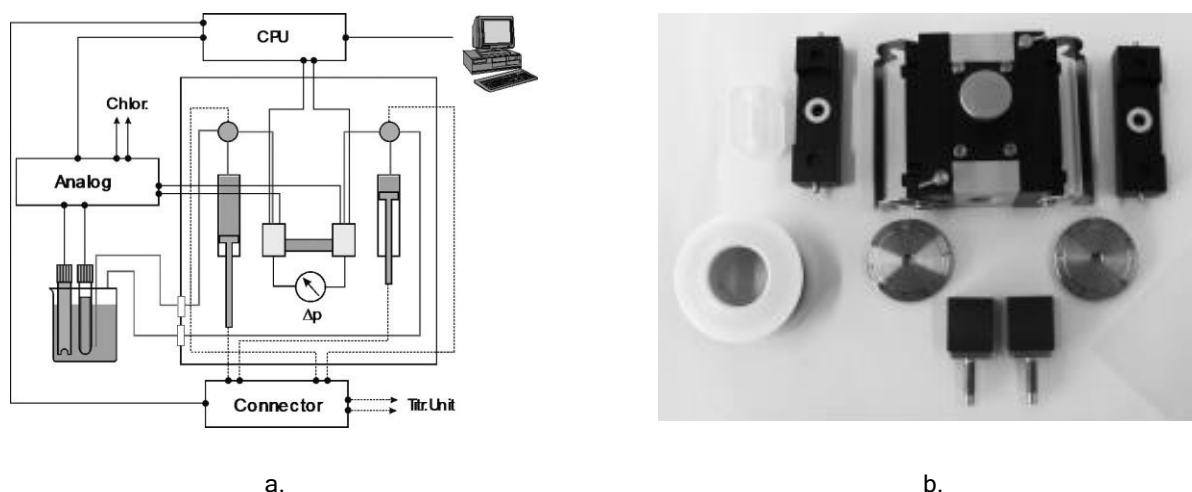

Figure 1: SurPASS electrokinetic analyzer: a) schematic view; b) Adjustable Gap Cell (AGC) [7]

3. Results and discussion

Figure 2 shows the results of the zeta potential of polyester standard fabric calculated from the values of the streaming potential measurements with other parameters [8] in the electrolyte solution at pH 6.0 which is maintained constant during time.

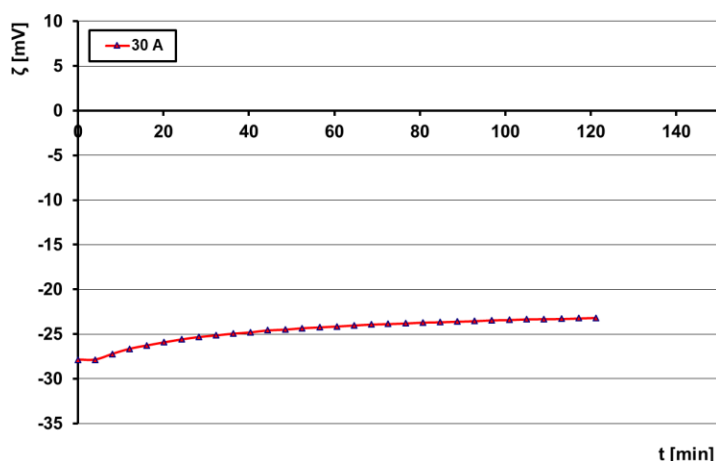

Figure 2: Zeta potential of standard polyester fabric 30A in mmol/L KCl at pH 6.0 depending on time

Figure 2 shows the change of zeta potential with time exposure to a 1 mmol/L KCl solution for standard polyester fabric at pH 6.0. Based on the electrokinetic behavior of the fabric under these conditions, a swelling capacity can be estimated as well as the time, in which the state of equilibrium was reached. Electrokinetic behavior of the polyester standard fabric is not stable because the values of the zeta potential of this fabric continuously decrease in small increments after 30 minutes. On this basis, it is assumed that surface of standard polyester fabric is covered by preparations that are gradually released due to the streaming of the electrolyte solution through the AGC with a sample of the polyester fabric.

The most unmodified textile materials are negatively charged in neutral aqueous solutions, which can be generated dually, by dissociation of characteristic functional groups or specific adsorption. Zeta potential of standard polyester fabric calculated from measurements of streaming potential in variation of pH of a 1 mmol/L KCl, Figure 3.

The polyester fabric possesses ester functional groups, hydrophobic character, high crystallinity and low reactivity, which contribute to generation of high magnitude of negative surface charge [9, 10]. However, the zeta potential curve of the standard polyester fabric labeled as 30A is not characteristic, since the values obtained are less negative than the literature presented values [9]. The reason for this anomaly may be presence of some preparations on the surface of the fabric, which covered surface and prevent the total dissociation of groups. Obtained results correlate with swelling behavior of a standard polyester fabric.

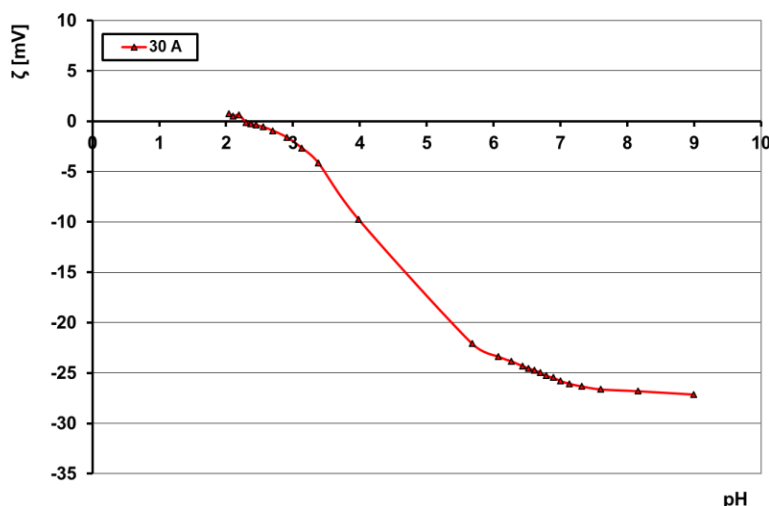

Figure 3: Zeta potential of standard polyester fabric (30A) in variation of pH of a 1 mmol/L KCl

The adsorption of CPC on standard polyester fabric in a 1 mmol/L KCl solution at pH 9.0, pH 6.0 and pH 4.0 was conducted in an electrokinetic analyzer SurPASS. After reaching the equilibrium state, the desorption of CPC from standard polyester fabrics was monitored in the same, closed monitoring system. Assessment of the CPC adsorption/desorption in the electrokinetic analyzer where a standard polyester fabric was adsorbent as well as desorbent is evaluated through three phases, Figure 4.

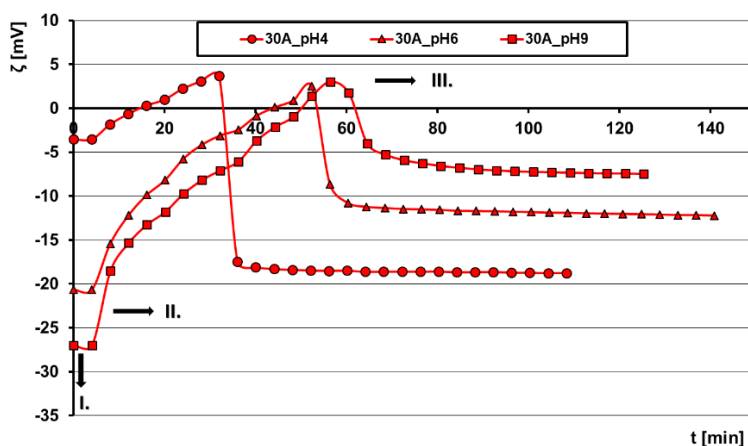

Figure 4: Standard polyester fabric 30A as adsorbent and desorbent in the electrokinetic system SurPASS in phase I, phase II and phase III

Phase I: zeta potential of standard polyester fabric 30A in a 1 mmol/L KCl at pH 9.0, pH 6.0 and pH 4.0

Phase II: zeta potential of standard polyester fabric 30A in a 1 mmol/L KCl at pH 9.0, pH 6.0 and pH 4.0 with gradual CPC dosing (adsorption)

Phase III: zeta potential of standard polyester fabric 30A with adsorbed CPC (from phase II) in a 1 mmol/L KCl at pH 6.0 (desorption).

The initial zeta potential of fabric 30A specified in phase I at pH 9.0 correspond to value -27.0 mV, at pH 6.0 (-21.0 mV) and at pH 4.0 (-3.5 mV), Figure 4. Magnitude of zeta potential at pH 9.0 and pH 6.0 correspond to the zeta potential values of standard polyester fabric presented in Figure 3. According to the results in Figure 3, polyester standard fabric at pH 4.0 possesses zeta potential -10.0 mV. It should be reasonable that starting point (value of zeta potential) at pH 4.0 in Figure 4 is the same or similar like in Figure 3. Since the results of zeta potential presented in Figure 3 are result of the gradual titration of polyester functional groups with HCl, the results in Figure 3 and Figure 4 are not in good correlation. An additional confirmation of the electrokinetic instability of the polyester standard fabric is the swelling behavior, presented in Figure 2. It is obvious that identified deposits on/in standard polyester fabric require purification with a proper solvent or special detergent,

able to remove embedded substances. The zeta potential of fabrics 30A (-3.5 mV) at pH 4.0 in phase I indicate that standard fabric at this pH value has small number of available active groups, so very low amount of CPC is required to reach the state of equilibrium. Adsorption curves of CPC in phase II, recorded for pH 6.0 and pH 9.0, are almost parallel. The amount of CPC to obtain a reverse charge is higher at pH 9.0 (78.30 µg/g) than at pH 6.0 (49.23 µg/g). Phase III conducted in the electrokinetic system after adsorption of CPC at pH 4.0, resulted with a steep CPC desorption curve where zeta potential of standard polyester fabric (-17.0 mV) indicate that CPC as well as preparations were removed in desorption phase. Desorption phase started after adsorption of CPC on standard polyester fabric at pH 6.0 and pH 9.0 indicate that CPC remained on the surface of standard polyester fabric.

4. Conclusion

The research dedicated to adsorption of CPC on standard polyester fabric as well as the CPC desorption designed through the surface characterization of standard fabric and the analysis of swelling capacity proved that electrokinetic system is suitable for qualification and quantification of CPC adsorption on standard fabric, as well as its desorption in the electrolyte solution.

Acknowledgement

The work has been supported by Croatian Science Foundation under the project UIP-2017-05-8780 HPROTEX.

References

- [1] Crutzen, A.: Fabric softeners, In *Liquid Detergents*, Lai K.Y., 2nd edition, CRC Press, ISBN 9780429116377SAD, (2006)
- [2] Soljačić, I., Pušić, T.: Čišćenje u vodenim medijima, *Njega tekstila-I dio*, Sveučilište u Zagrebu Tekstilno-tehnološki fakultet, ISBN 953-7105-09-1 Zagreb. (2005)
- [3] Roy, D. et al.: Antibacterial cellulose fiber via RAFT surface graft polymerization. *Biomacromolecules*, **9** (2007) 1, pp. 91-99, ISSN 15257797j
- [4] Haps, S., et al: The effect of cetylpyridinium chloride-containing mouth rinses as adjuncts to toothbrushing on plaque and parameters of gingival inflammation: a systematic review. *International journal of dental hygiene*, **6** (2008) 4, pp. 290-303.
- [5] Grgić, K. et al: Cellulosic Fabrics – Assessment of N-cetyl Pyridinium Chloride Adsorption and Desorption, *Proceedings of International textile, clothing & design conference*, Dragčević, Z.; Hursa Šajatović, A.; Vujasinović, E.(Ed.), pp. 116-121, ISSN 1847-7275, Dubrovnik, 10/2018., University of Zagreb Faculty of Textile Technology, Zagreb
- [6] T. Luxbacher; T. et al: The zeta potential of textile fabrics: a review, *Tekstil*, **65** (2016) 9-10, pp. 346-351, ISSN 0492-5882
- [7] *Instruction Manual SurPASS™ Electrokinetic Analyzer*; Copyright © Anton Paar GmbH, A48IB046en-B, Graz, Austria, (2013)
- [8] Luxbacher T.: *The ZETA Guide – Principles of the streaming potential technique*, Anton Paar GmbH, ISBN 978-3-200-03553-9, Graz, Austria, (2014)
- [9] Grancarić A.M.; Tarbuk A.; Pušić T.: Electrokinetic properties of textile fabrics, *Coloration technology*, **121** (2005) 4, pp. 221-227, ISSN 1472-3581
- [10] Pušić, T. et al: Adsorption and Desorption of Ionic Surfactants, *Tenside Surfactants Detergents*, **47** (2010) 3, pp. 173-178, ISSN 0932-3414

Authors:

Katia GRGIĆ, BSc (corresponding author)
Prof. Tanja PUŠIĆ, PhD
University of Zagreb Faculty of Textile Technology
Prilaz baruna Filipovića 28a, 10000 Zagreb, Croatia
Phone: +(385) (1) 3712 500

E-mail: katia.grgic@tff.hr
E-mail: tpusic@tff.unizg.hr

ANALYSIS OF METAL THREADS IN THE HISTORICAL CROATIAN TEXTILE FROM 17th TO 20th CENTURY

Kristina ŠIMIĆ; Ivo SOLJAČIĆ & Tihana PETROVIĆ LEŠ

Abstract: Metal threads, as decoration on historical Croatian textile, were mostly, used on the liturgical vestments and the festive folk costumes. Various types of metal thread were found, like independent metal threads and metal threads with non-metal textile yarn, in different location on the textile items. Analysis of these metal threads was performed with Scanning Electron Microscope with Energy Dispersive X-ray detector (SEM-EDX). The method was applied as suitable, determining the approximate amount of individual metals in the sample, also investigations of cross-sections along with the surfaces was performed. This method was compared with two other methods, X-Ray Fluorescence Spectroscopy (XRF) and Particle Induced X-Ray Spectroscopy (PIXE).

Keywords: Analysis, metal threads, folk costumes, liturgical vestments, SEM-EDX

1. Introduction

Metal threads are part of the historical Croatian textiles used usually for decoration of festive folk costumes, figure 1a and liturgical vestments, figure 1b. Textiles containing metal threads are inevitable items of cultural, social and religious life, representing something festive, expensive and worth of respect. Items decorated with metal threads were primarily handmade but less often made using machine [1].



Figure 1: Historical textile from which some samples of metal threads were taken: a. part of the folk costume (scarf) b. liturgical vestment (covering for the chalice)

First metal threads were narrow stripes directly incorporated in textiles, figure 2a. Second type of threads was metal wire, figure 2b. Later on special type of metal threads incurred as yarns created from a metal or even two metal threads with a non-metal textile yarn. Combined textile metallic yarn called “srma”, was made of metal threads or just one spiral wrapped around the non-metal textile yarn, which represent the core, figure 2c. This increased flexibility and even allowed different applicability [2-4]. Textile yarns were mostly made of silk or linen but sometimes it can be wool or cotton. Metal threads were primarily made of gold, silver, copper, or different alloys of these metals [5]. Recently aluminium is mostly used, it has silver shine that can replace and imitate silver and after a special procedure can even get a gold colour and shine [4, 6].

Primarily, metal threads have been abundant and frequently used on liturgical vestments giving all the splendour and grandeur to the clothes, worn during the celebration of the holy Mass. The oldest specimen from liturgical vestments with metal threads is Ladislav's mantle from the 11th century, stored in the Treasure of Zagreb Cathedral [1]. Croatian festive holiday costumes worn only for special ceremonial occasions such as weddings and other celebrations were extraordinary beautiful and decorated [7]. Folk costumes decorated

with metal threads are from the 19th and 20th century used for special occasions [1]. The study is focused on elemental analysis of the collected samples from cultural heritage. The result of this study help us understand history of metal threads on textiles and also give important information to restorers.

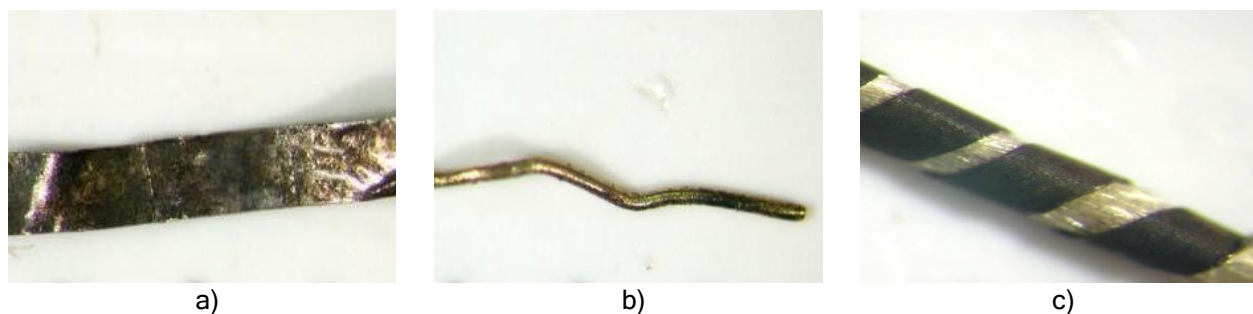

Figure 2: Metal threads: a. metal strip, b. metal wire, c. combined textile metallic yarn, “srma” [3]

2. Materials and methods

Metal threads, figure 2 can be either, woven into textiles or very often as part of a fringe hanging from textiles, but also it can be in the decorative ribbons stitched on textiles. Analysed samples of metal threads are from various Croatian museums and different textile items such as liturgical vestments and folk costumes. Sampling was performed with special permission of restorers and conservators, their supervision and cooperation in such way that the valuable historic textile is not damaged. Only hanging metal threads are taken, as samples, from the already damaged part of the textile which cannot be returned to the textile itself. Samples are also embedded in synthetic resin cubes and then polished until the cross section was seen for further analysis. Searching the literature and preliminary analysis have shown that the SEM-EDX is the best method for the analysis of historical textiles [8]. The measurements were performed with three techniques; SEM-EDX, XRF and PIXE. At the Faculty of Textile Technology SEM-EDX analysis was performed on the device Tescan MIRA FE-SEM, operating voltage 20 kV and working distance 25mm. Bruker AXS, Quantax EDX detector type SDD (Silicon Drift Detector) that performs detection of boron (B) to uranium (U) [3]. Scanning electron microscopy with energy dispersive X-ray spectroscopy is the best known and most widely used of the surface analytical techniques [8]. A scanning electron microscope (SEM) is a type of electron microscope that produces images of a sample by scanning it with a focused beam of electrons. The electrons interact with atoms in the sample, producing various signals that contain information about the sample's surface topography and composition. The types of signals produced by an SEM include secondary electrons (SE), backscattered electrons (BSE) and photons of characteristic X-rays, figure 3 [9].

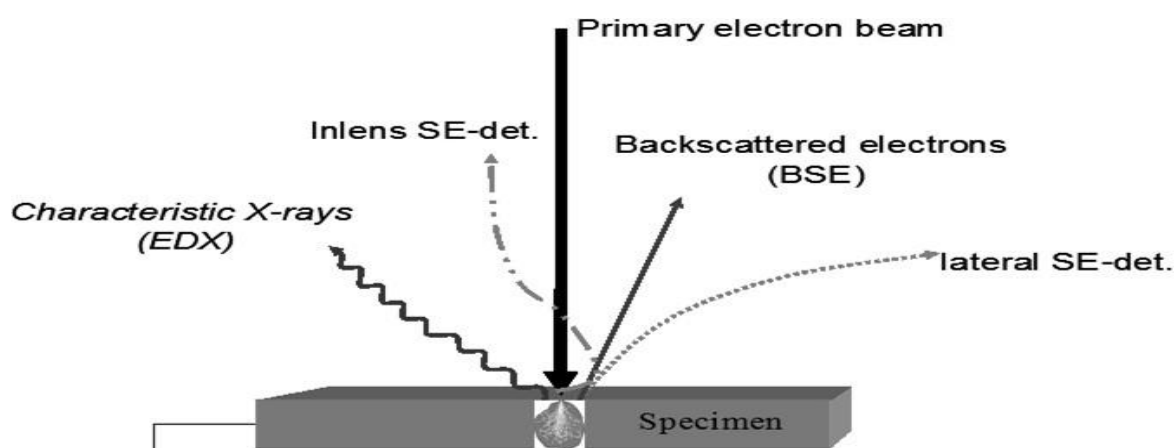

Figure 3: Shema of SEM-EDX [10]

The most common SEM mode is detection of secondary electrons emitted by atoms excited by the electron beam. The intensity of backscattered electrons can be correlated to the atomic number of the element within the sampling volume. Hence, some qualitative elemental information can be obtained. The analysis of characteristic X-rays (EDX analysis) emitted from the sample gives more quantitative elemental information. Analysis of the X-ray signals may be used to map the distribution and estimate the abundance of elements in

the sample [10]. XRF device Arttax, at the Croatian Conservation Institute, manufacturer Bruker, X-ray tube - the anode Rh, voltage 50 kV, intensity of 0.7 mA, a collimator X-ray beam of 0.6 mm, SDD detector XFLASH, Bruker, detection from K (Z = 19) to U (Z = 92) [11].

PIXE measurements were performed at the Ruđer Bošković Institute ion microprobe facility, which is described in detail elsewhere [12]. The 1 MV Tandetron accelerator provided 2 MeV proton beam which was focused by a triplet magnetic quadrupole lens system to a 2 μm spot size and raster scanned over selected sample areas. A rectangular or squared scan patterns were used with a different size (between 100x100 μm^2 and 1.3x1.3 mm²) and a variable number of pixels (up to 128x128). PIXE spectra were collected using Si(Li) detector placed at 135° relative to the beam direction at a distance of approximately 2 cm from the target. The effective X-ray energy resolution was about 160 eV (for the Mn K α line). Data were digitally recorded with the SPECTOR data acquisition software in a list file which can be replayed off-line. Afterwards, collected data were analysed with the GUPIXWin software [13] in iterative matrix mode and using normalization to 100 w%.

3. Results and Discussion

Metal threads from the historical Croatian textile were analysed qualitatively (and quantitatively for some samples) with XRF screening and quantitatively with SEM-EDX. High difference between XRF qualitative and EDX quantitative data, on some analysed samples, were observed. Because of these large deviations, samples were analysed by micro-PIXE device having a different depth of penetration 20 μm unlike XRF 100-200 μm and EDX 1 μm . The results obtained with EDX, XRF and PIXE analysis are similar for homogeneous samples, while for gold gilded and silver plated samples are different. Table 1 is showing only one example for Au gilded, Ag plated and one for alloy but there are much more examples like that. Due to less penetration depth EDX has a higher percentage of gold in gilded samples and silver in silver plated samples from PIXE and XRF. EDX results for gold in gilded samples are higher than PIXE and XRF results, because Au layer is present above the bulk Ag, also for silver plated samples Ag layer is present above the bulk Cu. To prove that samples are gold gilded or silver plated, EDX analysis of the cross section was presented. SEM-EDX analysis of cross sections confirmed assumptions and the presence of the layered structures on many samples [14].

Table 1: Differences in XRF, PIXE, EDX and EDX cross section analysis

Sample	Method	Au (%)	Ag (%)	Cu (%)
Au gilded	XRF	4,4	94,7	0,9
	PIXE	2,7	96,8	0,5
	EDX	18,3	81,5	0,2
	EDX cross section	0,2	99,5	0,3
Ag plated	XRF	0	10,8	89,2
	PIXE	0	16,7	83,3
	EDX	0	24,2	75,8
	EDX cross section	0	0,3	99,7
Alloy	XRF	0	3,1	96,9
	PIXE	0	3,3	96,7
	EDX	0	3,9	96,1
	EDX cross section	0	2,8	97,2

Difference in SEM-EDX analysis of cross section and surface shows metal threads structure, which threads are Au gilded and which are Ag plated. While very similar analysis results proofs that threads are alloys. This analytical methods show layered structure as well as chemical composition of different metal threads.

4. Conclusion

Selected metal threads from the historical Croatian textiles have been analysed for the first time by the three X-ray methods (SEM-EDX, XRF and PIXE). All three analysis showed similar quantitative results on homogeneous samples (alloys). In case of gold gilded or silver plated samples, SEM-EDX, PIXE and XRF showed very different quantitative results due to complex sample structure and geometry. Reliable analysis of gold gilded and silver plated samples by SEM-EDX requires measurements of cross sections as well. SEM-EDX method is the most suitable and the most widely used of the surface analytical techniques for metal content analysis of metal threads from historical textiles. The method is simple, reliable and reproducible. Analysis shows the main metals in the metal thread samples as well as the trace elements. The surface gold layer was found on the silver core thread while the surface silver layer is related to the copper core threads.

Analysis of metal threads gave us very valuable information about the old manufacturing techniques and about the appropriate treatment for cleaning and conservation of the precious historical textiles.

References

- [1] Šimić, K.; Soljačić, I. & Pušić, T.: Application of metal threads in Croatia from the 11th to the 20th century, *Tekstil*, **62**. (2013) 3-4., pp. 112-121, ISSN 0492-5882
- [2] Hacke, A.-M.; Carr C.M. & Brown A.: Characterisation of metal threads in Renaissance tapestries, Available from http://www.nma.gov.au/data/assets/pdf_file/0010/346069/NMA_metals_s4_p01_characterisation_metal_threads.pdf Accessed: 2019-11-28
- [3] Karatzani, A.: Metal threads: the historical development, Available from http://conferences.saxo.ku.dk/traditionaltextilecraft/keynote_speakers/presentations/Anna_Karatzani.pdf Accessed: 2019-11-28
- [4] Raffaelli, D.; Čunko, R. & Dragičević, M.: Istraživanja srme s tla Dalmacije u razmaku od tisuću godina, *Tekstil*, **31**. (1982) 12., pp. 827-838, ISSN 0492-5882
- [5] Csiszár, G., Ungár, T., Járó, M.: Correlation between the sub-structure parameters and the manufacturing technologies of metal threads in historical textiles using X-ray line profile analysis, *Applied Physics A*, **111**. (2013) 3., pp. 897-906, ISSN 0947-8396
- [6] Rezić, I.; Bokić, Lj. & Soljačić, I.: Metalni predmeti i metalna vlakna na povijesnim i suvremenim tekstilnim predmetima, *Tekstil*, **58**. (2009) 3., pp. 93-104, ISSN 0492-5882
- [7] Soljačić, I.; Čunko, R.: Hrvatski tekstil kroz povijest, *Tekstil*, **43**. (1994) 11., pp. 584-602, ISSN 0492-5882
- [8] Ahmed, H. E.: A new approach to the conservation of metallic embroidery threads in historic textile objects from private collections, *International Journal of Conservation Science*, **5**. (2014) 1., pp. 21-34, ISSN 2067-533X
- [9] Turalija, M.; Bischof Vukušić, S. & Katović, D.: Primjena skenirajućeg elektronskog mikroskopa za tekstil, *Tekstil*, **58**. (2009) 12., pp. 640-649, ISSN 0492-5882
- [10] Mršić, G.; Žugaj, S.: Analiza GSR čestica upotrebom elektronskog mikroskopa (SEM/EDX), *Policija i Sigurnost*, **16**. (2007) 3-4., pp. 179-200, ISSN 1848-428X
- [11] Šimić, K.; Mudronja, D.; Pušić, T.; Soljačić, I.: Analysis of metal threads on historical Croatian textiles, Proceedings for the 8th international textile, clothing & design conference, Dragčević, Z. (Ed.), pp. 89-93, ISBN 1847-7275, Dubrovnik, October 2016, University of Zagreb, Faculty of Textile Technology, Zagreb, (2016)
- [12] Jakšić, M.; Bogdanović Radović, I.; Bogovac, M.; Desnica, V.; Fazinić, S.; Karlušić, M.; Medunić, Z.; Muto, H.; Pastuović, Ž.; Siketić, Z.; Skukan, N.; Tadić, T.: New capabilities of the Zagreb ion microbeam system, *Nuclear Instruments and Methods in Physics Research Section B*, **260**. (2007) pp. 114-118, ISSN 0168-583X
- [13] Campbell, J.L.; Boyd, N.I.; Grassi, N.; Bonnick, P.; Maxwell, J.A.: The Guelph PIXE software package IV, *Nuclear Instruments and Methods in Physics Research Section B*, **268**. (2010) pp. 3356-3363, ISSN 0168-583X
- [14] Šimić, K.; Zamboni, I.; Fazinić, S.; Mudronja, D.; Sović, L.; Gouasmia, S.; Soljačić, I.: Comparative analysis of textile metal threads from liturgical vestment and folk costumes in Croatia, *Nuclear Instruments and Methods in Physics Research Section B*, **417**. (2017) pp. 115-120, ISSN 0168-583X

Authors:

B. Sc. Kristina ŠIMIC (corresponding author)

University of Zagreb. Faculty of Textile Technology. Department of Textile Chemistry and Ecology

Prilaz baruna Filipovića 28a. HR-10000 Zagreb. Croatia

Phone: +(385) (1) 4877 353

Fax: +(385) (1) 4877 354

E-mail: kristina.simic@ttf.hr

Prof. emeritus Ivo SOLJAČIĆ. PhD.

University of Zagreb. Faculty of Textile Technology. Department of Textile Chemistry and Ecology

Prilaz baruna Filipovića 28a. HR-10000 Zagreb. Croatia

Phone: +(385) (1) 4877 351

Fax: +(385) (1) 4877 354

E-mail: ivo.soljadic@ttf.hr

Prof. Tihana Petrović Leš. PhD.

University of Zagreb. Faculty of Philosophy. Department of Ethnology and Cultural Anthropology

Ivana Lučića 3. HR-10000 Zagreb. Croatia

Phone: +(385) (1) 4092 129

E-mail: tples@ffzg.hr

APPLYING IMAGE ANALYSIS FOR MEASURING THE DENSITY OF HISTORICAL TEXTILES

Mateo Miguel KODRIČ KESOVIA & Željko PENAVA

Abstract: *The aim of this interdisciplinary research was to develop method of measuring density of yarns of historical textiles based on precisely captured digital micrographs. Such tool will minimize necessary handling of fragile textile artifacts and allow experts of different scientific disciplines (historians, technologists, conservation-restorers, etc.) to quickly and effectively determine key information for technical documentation of historical textiles. It will represent an alternative, but more favorable solution to analyse the yarn density of historical textiles fabrics rather than classical material decomposition method which involves microdestructive separation of individual yarns from fabric structure. The principal hypothesis established in this paper is that there is no difference between results of measuring fabric density with image analysis and with conventional methods. Conducted statistical analysis has proven that all test results for all comparisons showed that significance threshold has a value above ($p > 0.05$), which means that the results of fabric density between manual and proposed method are statistically not significantly different therefore the initial hypothesis is being accepted.*

Keywords: *historical textiles, fabric density, image analysis, technical documentation, statistical analysis*

1. Introduction

Fabrics are the most widespread products in textile industry, both past and present. They are flat textile products designed for various applications with predefined structural elements. One of the most important structural element is the density of fabrics because it considerably affects the physical and mechanical properties of the textile material. The warp and weft yarns in the fabric are arranged properly and presented together in specific proportions. The fabric density is defined as number of warps or wefts within a metric length unit or fabric width. Structural parameters of historical fabrics are of great interest to experts because they reveal the complexity of textile production and provide insight into technical specifications, but also into the development of hand-woven techniques and technology through history. The international guidelines of conservation and restoration strictly stipulates that only non-destructive or, in exceptional cases, micro-destructive analytical research methods may be conducted on cultural objects due to their documentary value. Researching historical fabrics thus requires using methods that will not compromise the aesthetic, historical and physical integrity of the analyzed textile materials. In conservation and restoration of textiles, a systematic analysis of the cultural object is performed prior to selecting suitable conservation and restoration methods and conducting interventions. The state of the object before the treatment is documented, and it includes basic object information (about cultural heritage), the technology and specific features of production, deteriorations, collected historical data, etc. [1]. At the beginning of this century, computer aided design of aesthetic design became a common way of preparing the production of fabrics and other textile flat products [2]. The use of computer graphics for conservators and restorers requires specific knowledge, the use of specialized programs, and an understanding of the specific structures and problems involved with the fabrics under study [3]. Non-destructive analysis of fabric structural parameters and their decomposition is one of the basic steps for acquiring a basic knowledge of the process and technique of making historical textiles, as well as knowledge of recognizing the basic parameters of the textile, its subtypes, its function and terminology [4]. The analysis of old fabric samples is of utmost importance in order to gain an understanding of the manner in which the patterns are made and the origin and, if possible, their reproduction today [5]. Recently, several studies have dealt with the automatic measurement of weave density based on image analysis. Image processing has proven to be an effective method of analyzing fabric structure. The authors have introduced a gray-line profile method that is computationally simple and can be applied to different types of weaves [6, 7]. However, the direction of the warp and weft yarns must be parallel to the fabric image axes. There are various conventional methods for measuring fabric density. Conventional methods of measurement usually require manual operations, which are time-consuming and demanding for the eyes of the textile analyst. Therefore, it is highly desirable to develop an automatic fabric density determination system. In this research, the proposed image processing method for measuring fabric density is the pixel counting method. The aim of this research is to develop a method of measuring the density of yarns in historical textile materials based on a precisely captured digital image of the fabric. In this paper, the basic hypothesis is that there is no difference between the results of measuring the density of fabrics using image analysis and the conventional method. Furthermore, the

efficiency and accuracy of the image processing method used is specifically investigated and compared with the manual method.

2. Fabric density

The fabric quality depends in great measure on the density of warp and weft yarns. The fabric density represents a number of yarns (warps or wefts) within a metric length unit. With woven fabrics, the most common representation is the yarn density per unit length (usually in 1 or 10 centimeters), which is why the measurement unit for yarn density in fabrics is cm^{-1} or dm^{-1} . The warp density is determined by threading the warp ends through the reed (the number of yarns per dent) and the reed density itself. The fabric width is directly dependable on warp density that even a slightest change will influence the width of fabric as well. The interlacement of warp and weft yarns results in shrinkage of the fabric. The weft density is determined by the type and the settings of the fabric take up motion, as well as by the tensions that dominate in the weaving process. The warp density is defined at the very beginning and it is constant, while the weft density may be changed and adjusted if desired during the weaving process. The warp or weft densities - their ratio, the interspace between two yarns, i.e. the space between the centerlines of two adjacent yarns, as well as the yarn thickness – are very important structural parameters of the fabrics. When marking the density of yarns, the warp density (g_o) and weft density (g_p) are expressed separately. According to their density, the fabrics are divided into solid, medium and loosely woven fabrics. Solid woven fabrics are those where the gap between adjacent yarns is smaller than the diameter of the yarn. Medium woven fabrics are those where the gap between adjacent yarns is equal to the diameter of the yarn. Loosely woven fabrics are those in which there is a larger gap between the yarns than the diameter of the yarn.

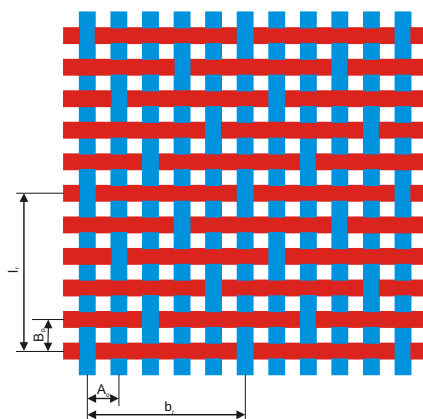

Figure 1: Woven fabric structure

The warp or weft densities per 1 cm are given with the following formulas (1):

$$g_o = \frac{10}{A_o} (\text{cm}^{-1}), g_p = \frac{10}{B_p} (\text{cm}^{-1}) \quad (1)$$

Where are: g_o is the warp density (cm^{-1}), g_p is the weft density (cm^{-1}), A_o is the elementary fabric width (mm) or the space between the centerlines of two adjacent warp yarns, B_p is the elementary fabric length (mm) or the space between the centerlines of two adjacent weft yarns, Figure 1. Depending upon the type of weave used, its weave unit will take over a specified surface of the fabric. The warp repeat (R_o) will be set with regards to its width (b_r), while the weft repeat (R_p) will be set with regards to its length (l_r). Since the number of warp and weft yarns within the weave repeat is known, the density can be determined by the following formulas (2):

$$g_o = \frac{10 \cdot R_o}{b_r} (\text{cm}^{-1}), g_p = \frac{10 \cdot R_p}{l_r} (\text{cm}^{-1}) \quad (2)$$

Where are: R_o is the warp repeat or the number of warp yarns within the weave repeat, R_p is the weft repeat or the number of weft yarns within the weave repeat, b_r is the weave repeat width (mm), l_r is the weave repeat length (mm).

3. Experimental testing

For the purpose of this study, analysis of fabric density was carried out on a total of ten different historical damasks. The selected fabric samples originate from different time periods - with a valuable 16th century damask from the island of Lopud (LOPUD / ŠUNJ / BURSA 6) standing out - and originating from different

areas of the Dubrovnik region. These are primarily antique church textiles (inv. No.: 2a; 2e; 3c; 4a; LOPUD / ŠUNJ / BURSA 6; UNIDU/T/1), as well as museum objects (DUM 306T; DUM 40T) and private collectibles (Sample 3; Sample 8) shown in Figure 2. The applied methods for measuring the yarn density on historical fabrics are in accordance with the Code of Ethics and the methodology of conservation-restoration profession.

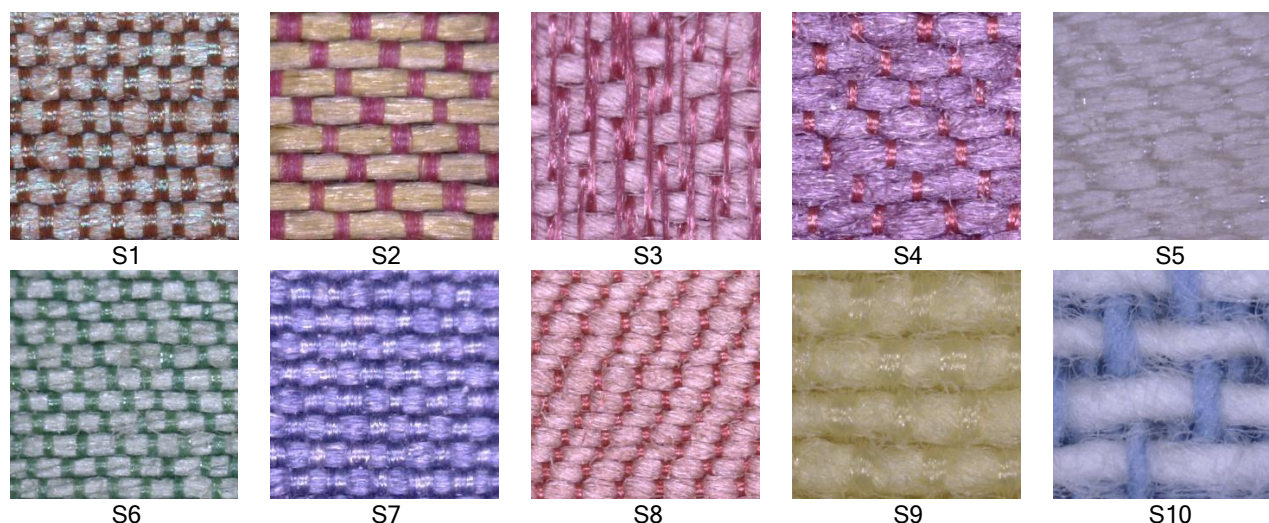

Figure 2: Pictures of fabric samples S1-S10

With the classical method for visually determining the fabric density, using a specialized magnifying glass Fadenzähler "Print" (Baladéo Art.Nr: PLR000161) with a magnification of 10x, the warp and weft yarns were manually counted within one centimeter. A standard ISO 7211-2:1984 was used to determine the number of yarns per unit length. In this process, the decomposition of the fabrics was not carried out, i.e. the separation of the yarns from the woven structure, in order to fully preserve the physical integrity of the historical textile material by a non-destructive approach. Damask is a woven type of patterned fabric, consisting of a combination of a warp and a weft effect of the same or different weave structure, where one effect creates the background and the other the pattern effect. Table 1 shows the analyzed samples of damask fabrics that includes combinations of 5-end sateen and 8-end sateen, as well as twill weave in weaving, different colored warp and weft yarns, a wide range of base densities (30 to 146 cm⁻¹) and a slightly smaller range of weft densities (17 to 44 cm⁻¹).

Table 1: Test results for basic fabric parameters

Sample code	Code	Weave	Warp color	Weft color	Density warp (cm ⁻¹)	Density weft (cm ⁻¹)
S1	DUM 306T	5-end sateen	dark red	light red	146	26
S2	DUM 40T	5-end sateen	red	yellow	66	32
S3	Inv. Br. 2a	4-end twill	red	beige	60	36
S4	Inv. Br. 2e	8-end sateen	red	violet	120	32
S5	Inv. Br. 3c	8-end sateen	white	white	104	38
S6	Inv. Br. 4a	5-end sateen	green	gray	130	44
S7	Lopud/Šunj/Bursa 6	5-end sateen	violet	violet	123	36
S8	UNIDU/T/1	4-end twill	red	light red	94	52
S9	Uzorak 3	5-end sateen	yellow	yellow	70	18
S10	Uzorak 8	8-end sateen	blue	white	30	17

The obtained metrical values were verified and compared with yarn dimensions and densities measured by using Dino Lite Pro AM413T5 digital microscope (magnification 57.9x), and its Dino Capture 2.0 (v1.5.18A) software. The spacing between the warp yarns (A_o) or weft yarns (B_p) was measured on the recorded image of the fabric, by counting pixels. Afterwards, the pixel number was converted into a measuring unit, in millimeters, using calibration method. With calibration method the spacing between two yarns in pixels was converted into spacing between two yarns in millimeters (3):

$$A_o (mm) = \frac{1(mm) \cdot A_o (pixel)}{N_{calib}}, \quad B_p (mm) = \frac{1(mm) \cdot B_p (pixel)}{N_{calib}} \quad (3)$$

Where the number of pixels per length of 1 mm is expressed as N_{calib} .

With higher fabric densities, instead of measuring the spacing between two adjacent yarns, the length of one or more weave repeats is measured and the density is calculated using the formula (2). If the length of one weave repeat in pixels is measured, then the resulting number should be divided by the number of yarns that constitutes the weave repeat (R_o or R_p) and thus obtain the distance between two yarns A_o or B_p . In order to avoid possible deviations of the yarn densities formed during the hand-weaving process, five measurements on the same fabric structure of every woven historical fabric were taken and the arithmetic mean was calculated.

Table 2: Basic statistical values of warp density of samples obtained by manual operation and image processing

Sample code	Manual operation			Image processing		
	\bar{x} (cm ⁻¹)	s (cm ⁻¹)	CV (%)	\bar{x} (cm ⁻¹)	s (cm ⁻¹)	CV (%)
S1	145.2	0.4472	0.31	146.0	0.8959	0.61
S2	65.6	0.5477	0.83	65.6	0.4455	0.68
S3	60.0	1.0000	1.67	59.3	1.0150	1.71
S4	119.4	0.5477	0.46	120.0	1.2306	1.03
S5	103.6	0.5477	0.53	103.7	0.8824	0.85
S6	129.8	0.8367	0.64	130.1	1.1508	0.88
S7	122.6	0.8944	0.73	122.8	0.8910	0.73
S8	94.6	0.8944	0.95	94.0	1.1349	1.21
S9	70.2	1.0954	1.56	70.5	1.2694	1.80
S10	30.6	0.5477	1.79	30.2	0.6901	2.29

In Table 2 the basic statistical values for the warp density obtained by two methods: manual operation and image processing are compared. The calculated basic statistical values for both methods are: arithmetic mean (\bar{x}), standard deviation (s), and coefficient of variation (CV). The maximum deviation, i.e. the coefficient of variation for both methods, is for fabric S10 with the lowest warp density and is 1.79% for manual operation and for image processing is 2.29%. In both methods, the minimum deviations are for the fabric S1, which has the highest warp density. For manual operation CV is 0.31% and for image processing CV is 0.61%.

Table 3: Basic statistical values of weft density of samples obtained by manual operation and image processing

Sample code	Manual operation			Image processing		
	\bar{x} (cm ⁻¹)	s (cm ⁻¹)	CV (%)	\bar{x} (cm ⁻¹)	s (cm ⁻¹)	CV (%)
S1	26.0	1.0000	3.85	26.1	1.0592	4.06
S2	31.4	0.8944	2.85	31.9	0.8873	2.78
S3	35.6	0.8944	2.51	35.9	1.2961	3.61
S4	31.8	0.8367	2.63	31.9	0.8400	2.63
S5	37.6	0.8944	2.38	38.0	1.0611	2.80
S6	43.4	0.5477	1.26	43.6	0.7693	1.76
S7	36.4	0.5477	1.50	35.6	0.8171	2.30
S8	52.6	0.5477	1.04	52.3	0.6269	1.20
S9	18.8	0.4472	2.38	18.1	0.5208	2.88
S10	17.4	0.5477	3.15	17.5	0.6772	3.88

The basic statistical values for weft density obtained by manual operation and image processing are compared in Table 3. The maximum deviation in both methods is the fabric S1. For manual operation CV is 3.85% and for image processing CV is 4.06%. In both methods, the minimum deviations are for fabric S8 and for the manual operation CV is 1.04% and for the image processing CV it is 1.20%.

Table 4: ANOVA and t-test result of warp density of samples obtained by manual operation and image processing

Sample code	ANOVA		t-test			
	F	P-value	t	P-value two-tail	Mean Difference	Standard Error Difference
S1	0.7532	0.4107	-0.8679	0.4107	-0.7540	1.1761
S2	1.5801	0.2442	1.2570	0.2442	0.0230	0.5666
S3	0.0162	0.9020	0.1271	0.9020	0.7128	1.5491
S4	3.8581	0.0851	-1.9642	0.0851	-0.5945	0.9098
S5	0.6139	0.4559	-0.7835	0.4559	-0.1399	0.7575
S6	0.4247	0.5329	-0.6517	0.5329	-0.4805	1.0426

S7	0.0007	0.9798	0.0261	0.9798	-0.2210	1.3386
S8	0.8910	0.3728	-0.9439	0.3728	0.6054	1.6526
S9	0.0053	0.9438	0.0727	0.9438	-0.3034	1.7562
S10	0.0178	0.8970	-0.1336	0.8970	0.4077	0.8698

The results of the one-way analysis of variance (ANOVA) and the t-test (two-sample assuming equal variances) for the warp density are shown in Table 4. All F values are smaller than the critical value F (5.3177), which confirms that the variance is homogeneous. Also, the condition that ($P \geq 0.05$) is satisfied for all fabric samples which means that the variance is homogeneous. To determine the significance of the difference in warp density between the two methods, a t-test was applied. The analysis results for all fabric samples and for both methods show no significant statistical differences in measuring the warp density with manual operation and image processing at a significance level (0.05), ie at 95% statistical certainty. The critical t-value was read from the table in the book [8] based on the test significance level of 0.05 and the number of degrees of freedom ($df = 8$) and is 2.3060. Due to the critical t-value is higher than calculated, the difference between these two methods of determining the warp density is not statistically significant. The highest standard error difference for the warp is for fabric S9 and is 1.1761, and the lowest standard error difference for fabric S2 is 0.5666.

Table 5: ANOVA and t-test results of weft density of samples obtained by manual operation and image processing

Sample code	ANOVA		t-test			
	F	P-value	t	P-value two-tail	Mean Difference	Standard Error Difference
S1	0.0580	0.8157	0.2409	0.8157	-0.0647	1.0485
S2	0.0122	0.9148	0.1104	0.9148	-0.4870	0.2605
S3	1.9133	0.2040	-1.3832	0.2040	-0.3052	1.0253
S4	0.0720	0.7952	0.2684	0.7952	-0.0961	0.9438
S5	0.0708	0.7969	-0.2661	0.7969	-0.3503	1.2678
S6	0.0185	0.8953	-0.1359	0.8953	-0.1927	0.4618
S7	1.4754	0.2591	-1.2146	0.2591	0.8491	0.8716
S8	0.0031	0.9572	0.0554	0.9572	0.3073	0.9288
S9	0.4230	0.5337	-0.6503	0.5337	0.7184	0.7781
S10	0.0474	0.8332	-0.2176	0.8332	-0.0760	0.5821

Table 5 shows the results of one-factor analysis of variance (ANOVA) and t-test for weft density between manual operation and image processing. In the ANOVA statistical analysis, the critical F value (5.3177) is greater than the F value at all weft densities, confirming that the variance is homogeneous. Also, the condition that ($P \geq 0.05$) is satisfied for all fabric samples which means that the variance is homogeneous. An additional t-test was then performed to determine the significance of the difference in weft density between manual operation and image processing. The critical t-value was read from the table in the book [8] based on the test significance level of 0.05 and the number of degrees of freedom ($df = 8$) and is 2.3060. As the critical t-value is higher than calculated, the difference between the mean values of manual operation and image processing is not statistically significant. The highest standard error difference for the weft is for fabric S5 and is 1.2678, and the lowest standard error difference for fabric S2 is 0.2605.

4. Discussion of results

Statistical data processing was performed with a Microsoft Excel spreadsheet calculator and its Data Analysis tool. In order to confirm the proposed method, the results obtained were compared with the mean fabric density directly measured by the standard method. The basic assumptions for conducting a one-factor analysis of variance (ANOVA) are that the distribution by which the populations from which the samples were taken is normal and that the variance is homogeneous. It was found that the results between conventional method (manual operation) and the proposed method (image processing) did not differ significantly (from the 0.05 significance level). Another important guideline achieved in the study was comparison by t-test. The T-test is a statistical procedure for testing the significance of the difference between two samples by comparing their arithmetic means.

5. Conclusion

In this study, the effect of the pixel counting method for the purpose of determining the fabric density was examined. The above method has been found to have certain advantages that cannot be obtained by manual

counting. The pixel counting method does not require a pre-processing or filtering technique in its measurement. Therefore, it can be concluded that the measurement result of the proposed method shows the same result obtained by manual measurements. It was found that the fabric density results obtained by the manual method and the proposed pixel count method did not differ significantly (with 95% confidence) in the measurement of warp and weft density for all fabric samples. Considering the above facts, it can be concluded that the research found that the difference between the conventional method and the image processing method of determining the density of warp and weft is not statistically significant, which confirmed the hypothesis made by this research.

Acknowledgments

I would like to thank the former Director of the Dubrovnik Museums, Mrs. Pavica Vilać, who allowed scientific research to be carried out on damasks from the museum collection - both for the purposes of this paper and for doctoral dissertation. For the same reasons I thank Mrs. Božena Popić-Kurtela, MSc, Senior Expert Advisor-Conservator for the Movable Cultural Heritage of the Conservation Department in Dubrovnik, on project approvals and professional support in the development of the textile conservation and restoration profession in Dubrovnik. Many thanks to my colleague textile conservator, Mrs. Danijela Jemo, PhD, and all my students for their general support in my work.

References

- [1] Penava, Ž. & Jemo, D.: Tehnološka analiza žakardske tkanine u svrhu konzerviranja i restauriranja, 3. međunarodno znanstveno-stručno savjetovanje *Tekstilna znanost i gospodarstvo*, Ujević, D.; Penava, Ž. (Ed.), pp. 115-120, ISBN: 978-953-7105-35-8, Zagreb, January 2010, Sveučilište u Zagrebu Tekstilno-tehnološki fakultet Zagreb, (2010)
- [2] Penava, Ž.; Knežić, Ž. & Vilus, T.: Računalni program zPaint za dizajn jacquard tkanina, 8. znanstveno-stručno savjetovanje *Tekstilna znanost i gospodarstvo*, Bischof, S. ; Penava, Ž. (Ed.), pp 156-159, Croatia, ISSN: 1847-2877, Zagreb, January 2015, Sveučilište u Zagrebu Tekstilno-tehnološki fakultet, Zagreb, (2015)
- [3] Jemo, D. & Rolich, T.: Application of computer graphics in textile conservation during the documentation process, *Book of Proceedings of the 6th International Textile, Clothing & Design Conference*, Dragčević, Z. (Ed.), pp. 632-637, ISSN: 1847-7275, Dubrovnik, October 2012, University of Zagreb Faculty of Textile Technology, Zagreb, (2012)
- [4] Kodrič Kesovia, M. M. & Jemo, D.: Konstrukcijska analiza veza u tkanju tekstilnih materijala u dijagnostičkom istraživanju umjetničkih predmeta, *Godišnjak zaštite spomenika kulture Hrvatske*, Vol. 36 (2014), pp. 163-172, ISSN: 0350-2589
- [5] Jemo, D. & Kovačević, S.: Tekstilno-tehnološka analiza starih tkanina velikih i složenih uzoraka, *Tekstil : časopis za tekstilnu tehnologiju i konfekciju*, Vol. 60 (2011) 5, pp. 265-270, ISSN: 0492-5882
- [6] Pan R. & et al.: Automatic Inspection of Woven Fabric Density of Solid Colour Fabric Density by the Hough Transform, *Fibres & Textiles in Eastern Europe*, Vol. 18 (2010) 4, pp. 46-51, ISSN: 1230-3666
- [7] Jeong J.: Novel Technique to Align Fabric in Image Analysis, *Textile Research Journal*, Vol. 78 (2008) 4, pp. 304-310, ISSN: 0040-5175
- [8] Pavlič, I.: *Statistička teorija i primjena*, Tehnička knjiga, ISBN: 867059076X, Zagreb, (1988)

Authors:

Mateo Miguel KODRIČ KESOVIA, M.A. (corresponding author)

University of Dubrovnik, Department of Art and Restoration

Branitelja Dubrovnika 41, HR-20000 Dubrovnik, Croatia

Phone: +(385) (20) 446 039

Fax: +(385) (1) 3712 533

E-mail: mmkesov@unidu.hr

Prof. Željko PENAVA, Ph.D.

University of Zagreb, Faculty of Textile Technology, Department of Textile Design and Management

Prilaz baruna Filipovića 28a, HR-10000 Zagreb, Croatia

Phone: +(385) (1) 3712 576

Fax: +(385) (1) 3712 533

E-mail: zeljko.penava@ttf.hr

TEXTILE DUST GENERATION FROM COTTON AND COTTON/POLYESTER BLEND FABRICS

Rajna MALINAR & Sandra FLINČEC GRGAC

Abstract: *Textiles generate large amount of particles, which are possible sources of infections. To explore different factors for dust generation, standard cotton and cotton/polyester blend fabrics were subjected to multiple washing and drying procedures, as base study for future research in reducing particle release in atmosphere. Samples were tested after 1, 5 and 10 washing and drying cycles. The results have shown considerable increase of dust generation within multiple washing and drying cycles. Cotton fabric had significantly higher dust output than cotton/polyester blend fabric due to differences in fibre surface morphology and sequentially higher friction between cotton fibres.*

Keywords: *cotton fabric; cotton/polyester; particle generation; textile dust; textile care.*

1. Introduction

As airborne diseases continuously generate problems of lesser and larger extent, effort can be made to diminish them from textile industry point of view. In large part, pathogens are transmitted through dust – airborne dust, which can be inhaled, or deposited dust, which can serve as feeding ground for bacteria and fungi [1-6]. Textile dust, which is most commonly organic in structure and also abundant in air, is therefore a source of transmission that can be reduced.

As previous studies have shown, textile dust generation increases with multiple washing procedures [7]. For larger scale investigation on possibilities for reduced textile dust generation, a baseline study with standard materials and standard washing procedure was needed. As most common materials, cotton and cotton/polyester blend fabrics were chosen. Since textile dust generation can be connected with mechanical damages, tensile properties were monitored as well.

2. Material and Methods

For this research fabric by WFK was used; standard cotton (100%) and cotton/polyester blend (65%/35%).

Samples were washed in accordance with ISO 6330:2012 [8] in washing machine Wascator FOM71 CLS (Electrolux). Program 6N with washing temperature of 60°C and Reference detergent with phosphates and without optical brighteners were used. Washing procedure was performed 10 times and samples were separated after first, fifth and tenth washing cycle. Between every washing cycle, all of the samples were dried on a roller (Elektronska industrija, type E/750).

Tensile strength and elongation were determined for said samples on MesdanLab Strength Tester in accordance with BS EN ISO 13934-1 [9], applying sample length 100 mm, clamp speed 100 mm/min, pretension 2 N.

Particle generation was measured on laser particle counter LasAir III (Particle Measuring Systems) connected to particle generator inside laminar air-flow cabinet (Fig.1). Sample was mounted on particle generator and exposed to controlled flexing. Number of released particles during testing is measured in following size categories: 0,3 µm for particle sizes 0,3-0,5 µm; 0,5 µm for particle sizes 0,5-1 µm; 1 µm for particle sizes 1-5 µm; 5 µm for particle sizes 5-10 µm; 10 µm for particle sizes 10-25 µm; 25 µm for particle sizes larger than 25 µm. Sample size was 5. This method was adopted from EN ISO 9073-10 [10], with adjustment of testing time to 30 min.

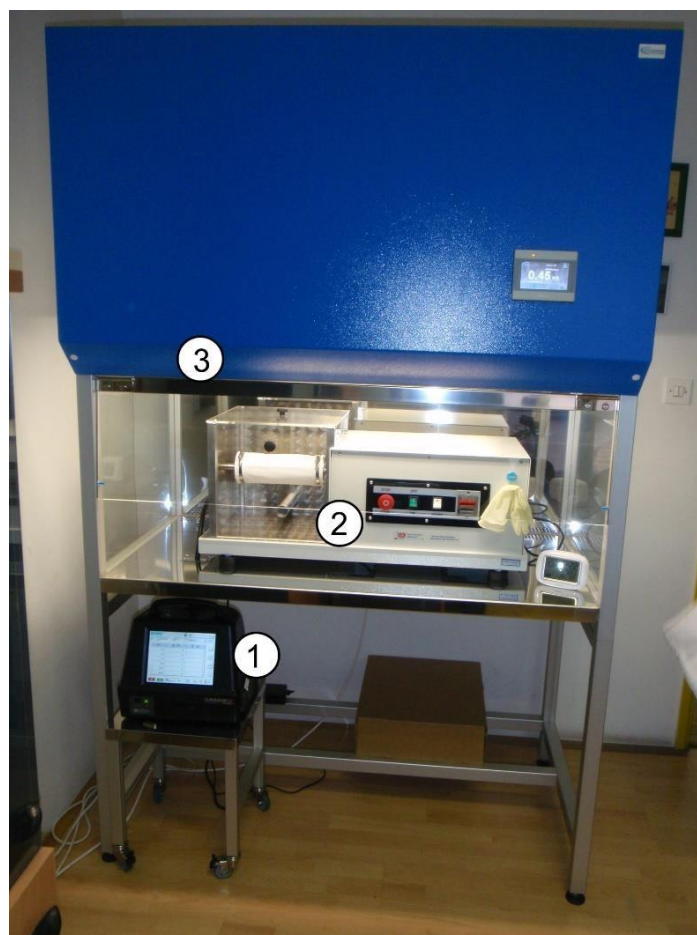

Figure 1: Particle counter (1) connected with a hose to particle generation unit (2) inside laminar air-flow cabinet (3)

3. Results and Discussion

Tensile properties of samples are presented in Table 1. Cotton fabric samples show a little less strength than blend fabric, as can be expected due to higher strength properties of polyester fibres. After 5 washing cycles, breaking force decreases due to mechanical damages. The increase after 10 washing cycles is caused by shrinking of fabric.

Table 1: Breaking force and elongation

Material	No. of washing cycles	Warp		Weft	
		Average of breaking force [N]	Average of elongation [%]	Average of breaking force [N]	Average of elongation [%]
Cotton	1	864.0	14.70	967.3	27.10
	5	797.5	16.80	782.3	25.60
	10	850.3	17.70	943.3	28.40
Cotton/ polyester	1	1225.7	17.40	1052.7	28.30
	5	1176.0	15.90	1040.7	30.00
	10	1186.5	16.65	1059.5	29.85

Particle count for all samples is shown in Table 2. Differences between cotton and cotton/polyester blend fabric are evident. In average, cotton fabric has produced 30 times more particles than cotton/polyester blend. This is noticeable across all particle sizes, with emphasis on particles smaller than 5 μm . Possible reason for better performance of cotton/polyester blend is less friction between fibres due to the smooth surface of the polyester fibres. Also, since cellulosic fibre is prone to repeated swelling in multiple washing cycles, its surface is likely to deteriorate more quickly than polyester.

Table 2: Sum of generated particles in 30 min by sizes

Material	No. of washing cycles	Average of 0,3 μm	Average of 0,5 μm	Average of 1 μm	Average of 5 μm	Average of 10 μm	Average of 25 μm
Cotton	1	310989.3	249744.5	173854.0	6864.5	1272.5	273.3
	5	1301249.2	931068.2	451463.8	13547.8	2451.0	272.6
	10	2140082.4	1541475.6	731622.2	22691.4	4149.4	387.0
Cotton/ polyester	1	17938.6	10743.6	5988.4	406.4	149.6	45.2
	5	31421.4	15471.8	6198.8	414.8	161.2	59.0
	10	45274.0	21650.4	9321.4	430.0	143.4	52.0

Multiple washing cycles have increased particle release from both samples. On Figure 2 is shown almost linear increase of dust generation by washing, with cotton sample showing higher leap between 1 and 10 cycles. This deterioration of material can be caused by mechanical and chemical influence during washing and drying cycles. Since tensile properties have not been reduced by much, it should also be noted that part of dust that is released from fabric could be from deposited particles, which are originally not from fabric itself. It is possible that detergent is not completely rinsed from fabric during washing process and, when dried, peels off during testing. The same is possible for mineral content from water used in washing. More washing cycles in future research could add insight into increased particle release as well as determine maximum of particle count/number of washing cycles ratio.

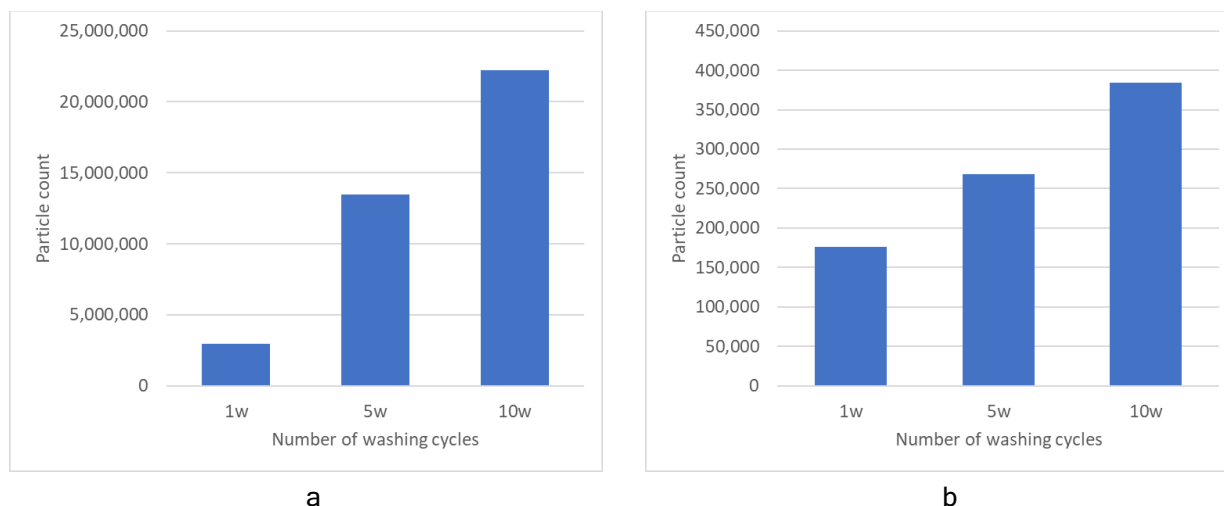

Figure 2: Sum of particles of all sizes for a) cotton samples and b) cotton/polyester samples

As washing procedure influences fabric, so is possible that part of textile dust is retained in water. This aspect of textile particle generation was not subject of current research. Even though environment and consequences for textile particles released in washing procedure are different from textile dust in atmosphere, two problems are connected and similar results can be derived, both for material and multiple washing cycles [11, 12].

4. Conclusion

The study aimed to obtain data on textile dust generation from standard cotton and cotton/polyester blend fabric. Cotton/polyester samples have shown much better results for all particle sizes measured. Particle generation was measured after 1, 5 and 10 washing cycles for both sets of samples and rise in dust release has been noted with increase of washing cycles. Testing after more washing cycles is recommended. For purposes of future investigation, this data will provide baseline for comparison with fabrics with antimicrobial finishes and reduced particle release.

Acknowledgments

This work has been supported in part by Croatian Science Foundation under the project UIP-2017-05-8780.

References

- [1] Sehulster, L. M.: Healthcare laundry and textiles in the united states: Review and commentary on contemporary infection prevention issues, *Infection Control and Hospital Epidemiology*, **36** (2015) 9, pp. 1073-1088, ISSN 0899823X
- [2] Fijan, S. & Turk, S. Š.: Hospital textiles, are they a possible vehicle for healthcare-associated infections?, *International Journal of Environmental Research and Public Health*, **9** (2012) 9, pp. 3330-3343, ISSN 1660-4601
- [3] Shiomori, T. *et al.*: Evaluation of bedmaking-related airborne and surface methicillin-resistant *Staphylococcus aureus* contamination, *Journal of Hospital Infection*, **50** (2002) 1, pp. 30-35, ISSN: 0195-6701
- [4] Neely, A. N. & Maley, M. P.: Survival of enterococci and staphylococci on hospital fabrics and plastic, *Journal of Clinical Microbiology*, **38** (2000) 2, pp. 724-726, ISSN 1098660X, 00951137.
- [5] Neely, A. N. & Orloff, M. M.: Survival of some medically important fungi on hospital fabrics and plastics, *Journal of Clinical Microbiology*, **39** (2001) 9, pp. 3360-3361, ISSN 1098660X, 00951137
- [6] Licina, D. & Nazaroff, W. W.: Clothing as a transport vector for airborne particles: Chamber study, *Indoor Air*, **28** (2018) 3, ISSN, 1600-0668
- [7] Malinar, R.; Flinčec Grgac, S. & Katović, D.: Generiranje tekstilne prašine kod tekstilija za jednokratnu i višekratnu namjenu, in *11th International Scientific Conference on Production Engineering Development and Modernization of Production*, Hodžić, A.; Omer, S. E.; Hodžić, D. (Ed.), pp. 495-498, ISSN: 2566-3275 Sarajevo, 10. 2017., University of Bihać, Technical faculty, Bihać, (2017)
- [8] ISO 6330 Textiles - Domestic washing and drying procedures for textile testing, 2012.
- [9] BS EN ISO 13934-1 Textiles – Tensile properties of fabrics. Part 1: Determination of maximum force and elongation at maximum force using the strip method, 1999.
- [10] ISO 9073-10 Textiles - Test methods for nonwovens - Part 10: Lint and other particles generation in the dry state, 2003.
- [11] Cesa, F. S. *et al.*: Laundering and textile parameters influence fibers release in household washings, *Environmental Pollution*, **257** (2020), ISSN: 0269-7491
- [12] Sillanpää, M. & Sainio, P.: Release of polyester and cotton fibers from textiles in machine washings, *Environmental Science and Pollution Research*, **24** (2017) 23, pp. 19313-19321, ISSN 1614-7499, Print ISSN 0944-1344

Authors:

Assistant Rajna MALINAR, B. Sc. (corresponding author)
Assoc. Prof. Sandra FLINČEC GRGAC, PhD.
University of Zagreb Faculty of Textile Technology
Prilaz baruna Filipovića 28a, 10000 Zagreb, Croatia
E-mail:

E-mail: rmalinar@ttf.unizg.hr
E-mail: sflincec@ttf.unizg.hr

MODERN KNITTED FABRICS FOR UNDERWEAR

Željka PAVLOVIĆ & Zlatko VRLJIČAK

Abstract: In the total world production, the share of cotton fibres is gradually decreasing, so that new fibres are needed to replace or supplement them. A double bed circular knitting machine with a machine gauge of E17 was used to knit five samples of knitted fabrics in plain double jersey weft knitted structure made of 20 tex yarns. The samples were knitted using cotton, Lyocell, modal, micromodal and viscose yarns. The ring spinning method was used to spin cotton and micromodal yarns, Lyocell yarns were spun using the air-jet spinning method, modal yarns were spun using the rotor spinning method, and viscose yarns were spun using the SIRO spinning method. The structure parameters and the tensile properties were determined for the unfinished and finished knitted fabrics, with emphasis on the percentage of elasticity when the knitted fabric was stretched in the course and wale direction. The mass per unit area of the analysed knitted fabrics ranged from 128 to 180 g/m², while the volume mass ranged from 0.21 to 0.40 g/cm³. All the manufactured and analysed knitted fabrics were compared with cotton knitted fabrics.

Keywords: Knitted fabric, double knit structure, underwear, raw material composition, cotton, modal, micromodal, Lyocell, viscose, SIRO

1. Introduction

In the total world production, the share of cotton fibres is gradually decreasing. In 2017, the world's total production of 100 million tons of fibres was exceeded for the first time, with cotton accounting for around 28%, or 28 million t. Cotton fibres are mainly used for making single yarns [1,2]. Yarns with counts of 14, 17, 20, 22 and 25 tex are widely used for the production of various knitted fabrics that are used to make more lightweight clothing, most commonly underwear or summer wear. Classic knitted underwear is most commonly made of cotton single jersey weft knitted fabrics, double jersey weft knitted fabrics and interlock fabrics. One part of the women's lingerie is made of polyamide warp knitted fabrics. For the production of classical women's lingerie, single cotton yarns with counts of 14, 17 and 20 tex are mostly used. For the production of knitted fabrics single bed circular knitting machines with gauges of E18, E20, E24 or E28 are used to make knitted fabrics with mass per unit area of 80 to 140 g/m², Fig. 1. Men's classic underwear is made of knitted fabrics with mass per unit area of 140 to 200 g/m². For its manufacture, cotton yarns of 17, 20, 22 or 25 tex are also used, as well as single or double bed circular knitting machines of the mentioned gauges. Quality winter men's underwear has a mass per unit area from 180 to 250 g/m² and is made of single cotton yarns of 17 or 20 tex, most commonly on interlock knitting machines of the specified gauge. Pyjamas and nightgowns are also made of these knitted fabrics. However, ply yarns of 10 tex x 2, 14 tex x 2 or 17 tex x 2 are sometimes used for their manufacture. Men's winter, bulky pyjamas are made of cotton plush knitted fabric with a mass per unit area from 200 to 350 g/m², [3,4].



Figure 1: Knitted underwear: a) women's underwear, b) men's underwear

For a number of reasons the share of cotton fibres in total world production decreases, while the population grows from year to year, and in 2019 the consumption of fibres per capita was about 13 kg. For this reason, research in the production of artificial fibres of plant origin is increasingly being conducted in the world. Such fibres have some properties similar to cotton fibres and are suitable for making knitted fabrics in various structures that adhere to the skin of the human body. The products are comfortable to use, easy to take care

of, not significantly expensive and environmentally friendly. For these purposes, viscose, Lyocell, modal, micromodal and other fibres are used in addition to cotton fibres. Such fibres and various spinning processes such as: ring-, rotor-, air-jet, compact and other spinning processes are used for making yarns with some properties better than classic cotton yarns made by employing the ring spinning process [5,6].

2. Structures and tensile properties of weft knitted fabrics

To make simpler knitted fabrics intended for classic underwear, single jersey, double jersey and plain interlock structures are mostly used. All the yarns used for knitted fabrics have the same raw material composition, structure, fineness and colour. In addition to the use of cotton yarns, modern yarns, which are interlooped independently or in combination with other yarns, are commonly used in the production of modern underwear, mostly in partial or single plaiting, Fig.2. In order to enhance the fit of the knitted fabric on the body and to increase the elasticity of the knitted fabric, in addition to the base yarn, the elastic yarn is interlooped in the course direction.

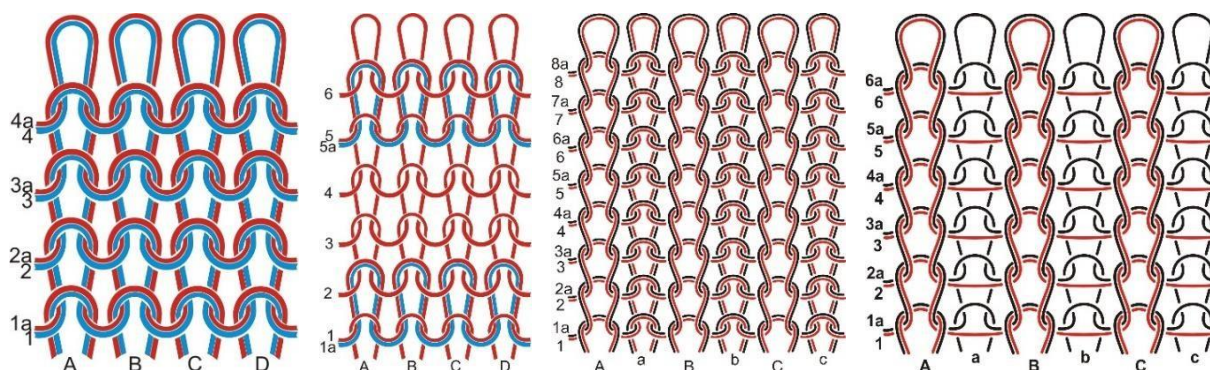

Figure 2: Single jersey weft knitted and double jersey weft knitted plated structures, which are mostly used to manufacture knitted fabrics for underwear

Plain single jersey weft knitted fabrics stretch about two times more in the course direction than in the wale direction, and double jersey weft knitted fabrics stretch up to five times more. When making knitted fabric for contemporary underwear, length contraction of the stretched knitted fabric is significant so that the knitted fabric fits the body comfortably. In the force / extension diagram, three regions are very often significant, Fig. 3.

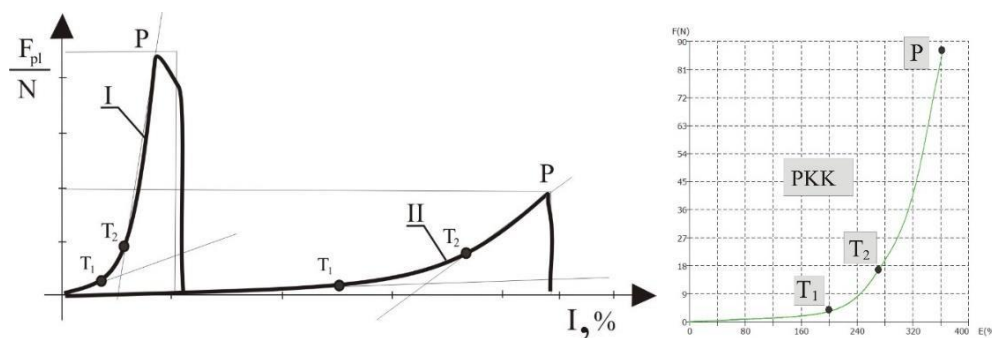

Figure 3: Force/extension diagrams for double jersey weft knitted fabric: a) extension diagrams of the knitted fabric in the wale direction (I) and in the course direction (II); T1 - end of the elastic region, T2 – point of the onset of plastic deformation, P – point of knitted fabric breakage, b) extension diagram of the knitted fabric in the course direction, knitted fabric made of a 20 tex yarn

It is assumed that the first, linear part of the diagram to point T1 represents the elastic region. The second part of the diagram from point T1 to point T2 encompasses the possibly elongated elastic region. This section can also be analysed as an entire region to the onset of permanent deformation. The part of the diagram from point T1 to point T2 represents the elastic limit or the part connecting the elastic region with the region of permanent deformation. The fourth part of the diagram ranges from point T2 to the point of knitted fabric breakage (P) and represents permanent or plastic deformation. During elongation and at the moment of breaking the knitted fabric, the tensile testing device records the elongation length at break and this information is often not debatable. However, it is not always easy and precise to determine, estimate or calculate the elastic region, i.e. point T1 or the onset of permanent deformation, i.e. point T2. For knitted fabrics made of

yarns of different raw materials, yarn counts and structures these regions have not been sufficiently studied. The elastic limit and the onset of permanent deformation are particularly interesting, as they are very important for the production of quality recreational, especially compression recreational clothing [7.8]. Yarns made of new fibres and by using modern spinning methods have a significantly different structure, and thus have properties compared to cotton yarns made by employing the ring spinning method. Due to different tensile properties of the yarn, different tensile properties of the knitted fabric are also expected, where it is desirable to find out the percentages in the indicated regions of the force/extension diagram. First of all, the elasticity of the knitted fabric or the extension of the fabric to point T1 is significant. In the manufacture of compression garments, the region between the edge of elasticity and the onset of permanent deformation is very significant, i.e., between points T1 and T2, while the percentage of permanent deformation is often not so significant in the garment manufacture. Due to the above, five types of yarn were made according to plan which were used to knit samples of knitted fabrics that can be used for making underwear, lightweight outerwear or recreational clothing. The structure parameters and the tensile properties were determined for knitted fabrics, with particular emphasis on the individual percentages of elongation of the knitted fabric.

3. Yarns and knitting machine for making knitted fabric samples

Five fibre types were used to make yarns: cotton, viscose, Lyocell, modal and micromodal fibres. The ring spinning method was used to spin cotton and micromodal fibres into yarns. The SIRO method was used to spin viscose fibres into yarns. The air-jet spinning method was used to spin Lyocell (Tencel) fibres into yarns, while the rotor spinning method was used to spin modal fibres [2, 9]. All the five yarn groups were made with a nominal count of 20 tex. Table 1 lists the basic parameters of tensile properties of the manufactured and analysed yarns at $p = 5$.

Table 1: Tensile properties of the yarns with a nominal count of 20 tex spun of different fibres and by employing different spinning methods

Yarn	Breaking force, cN	Breaking elongation, %	Breaking strength, cN/tex	Work of rupture, cN·cm
PKK	302 ± 5	3.7 ± 0.1	15.1 ± 0.3	301 ± 10
MMR	506 ± 11	9.5 ± 0.2	25.3 ± 0.6	1421 ± 50
SP	393 ± 7	13.6 ± 0.3	19.7 ± 0.4	1700 ± 59
TAJ	444 ± 12	7.9 ± 0.2	22.2 ± 0.6	1086 ± 56
MOE	325 ± 9	7.2 ± 0.2	16.3 ± 0.5	738 ± 32

where: PKK - cotton yarn spun on the ring spinning machine, MMR - micromodal yarn spun on the ring spinning machine, SP - viscose yarn spun by employing the SIRO spinning method, TAJ - Lyocell (Tencel) yarn spun on the air-jet spinning machine, MOE – modal yarn spun on the rotor spinning machine

The lowest breaking force of the yarn amounted to 302 ± 5 cN and was measured for the cotton yarn, and the highest one amounted to 506 ± 11 cN and was measured for the micromodal yarn and spun on the ring spinning machine. The lowest elongation at break amounted to 3.7 ± 0.1% and was measured for the cotton yarn and the highest one amounted to 13.6 ± 0.3% and was measured for the viscose SIRO spun yarn. The smallest amount of work was also measured for the cotton yarn and the greatest amount of work was measured for the viscose SIRO spun yarn. Based on the data obtained from measurements, it can be concluded that the analysed yarns differed significantly in their tensile properties and that all the measured values of tensile properties for the cotton yarn were the lowest. A double-bed circular knitting machine E17 was chosen to make knitted fabric samples [9]. During the finishing process, the knitted fabrics were washed at an initial temperature of 40 °C. Washing, bleaching and stabilizing agents were added and the temperature rose to 98°C. After rinsing, a cold wash was performed with neutralization and softening of knitted fabrics. After washing the knitted fabrics were dried at a temperature of 150 °C, while the material passed through the dryer at a speed of 0.15 m/s.

4. Results and discussion of structure parameters of knitted fabrics

Appropriate standards and methods were used to analyse basic or technological parameters of the structure of knitted fabrics as they are measured and analysed several times in daily production [10]. Some performance parameters relevant to these investigations were also calculated [11]. Measurements were made in a logical sequence, first those for which no material destruction was required, and then the knitted fabric was unknit and cut. When determining the average stitch length to form a stitch, it was necessary to cut the knitted fabric and to unravel the yarn. From among the performance parameters the following were analysed: knitted fabric shrinkage in the course direction after removal of the fabric from the knitting machine, coefficient of loop density

and volume mass of the knitted fabric, Table 3. The results were statistically processed where it was possible and purposeful with $p = 0.05$. **Knitted fabric width** (S_p) was measured in tubular form. All the made unfinished samples had the width ranging from 36 to 48 cm. The minimum width of the unfinished fabric was 18 cm x 2, (36 cm). It was obtained by knitting with viscose yarns spun by employing the SIRO spinning process (SP). It is important for knitting technologists to know that at the lowest width of the knitted fabric the greatest fabric shrinkage was observed after removal of the fabric from the knitting machine and relaxation, amounting to even 44%. The maximum width of the unfinished knitted fabric was 24.0 cm x 2, (48 cm). It was obtained in knitting Lyocell (Tencel) yarns by employing the air-jet spinning process (TAJ) and modal yarns spun on the rotor spinning machine (MOE). The lowest knitted fabric shrinkage was obtained after the removal from the machine and relaxation amounting to 25%. Based on these two substantially different data, it can be concluded that different yarn structures are obtained by employing the ring, air-jet, rotor and SIRO spinning process. The yarn spun on the rotor and air-jet spinning machine was stiffer. During the stitch formation, it forms a larger stitch skeleton than the stitch made on ring or SIRO spinning machines. This is the reason why wale spacing was larger, consequently the knitted fabric was wider. Knitted fabric finishing substantially changes fabric structure. The width of the finished knitted fabrics ranged from 19.0 cm x 2 to 21.5 cm x 2, (38 do 43 cm). After the finishing process, the knitted fabrics made of SIRO yarns were 16.7% wider, cotton fabrics 10.3% and micromodal fabrics 2.5%. In contrast to these samples, the knitted fabrics made of modal yarns and spun by employing the rotor spinning system (MOE) were 20.8% narrower after the finishing process, and the knitted fabrics made of Lyocell yarns and spun by employing the air-jet spinning process (TAJ) were 10.4% narrower. The cause of this different behaviour of the knitted fabrics after the finishing process should be sought in the structure of fibres, yarn and finishing process, i.e. it is necessary to investigate the optimal parameters of the finishing process for individual raw material compositions and yarn structures. **Stitch length** (ℓ) is one of the basic parameters, especially for plain knitted fabric structures. For the unfinished and finished knitted fabrics, it ranged from 3.05 ± 0.00 mm to 3.15 ± 0.02 mm with a difference of 3.2%, which is significantly less than 5%, so for practical considerations it can be concluded that stitch length does not differ significantly for all analysed knitted fabrics. This is also one of the data that indicates that the samples were knitted under the same knitting conditions. **Coefficient of stitch density** (C) describes the general stitch density of the knitted fabric [9], ($C = D_h / D_v = B/A$). For the analysed knitted fabrics it ranged from 0.72 to 0.97, which mainly corresponds to the commercial usage of such knitted fabrics for various purposes. **Mass per square meter of the knitted fabric or mass per unit area** (m) is the most significant structure parameter, especially for plain knitted structures [3,9,11]. It determines the purpose and price of the product. For the analysed unfinished samples, the mass per square meter of the knitted fabric ranged from 128 ± 3 to 180 ± 5 g / m², and for the finished ones from 147 ± 3 to 170 ± 4 g/m². After the finishing process, the mass per unit area significantly decreased for some fabrics, and it increased significantly for some fabrics. Therefore, for each knitted fabric sample the optimum finishing parameters for knitted fabrics should be found. These results are very important for batch and commercial production as they suggest the practical conclusion that it is very complex to make knitted fabrics of one mass per unit area using yarns with the same yarn count, which have different raw material compositions and are spun by employing different spinning methods.

Table 3: Structure parameters of unfinished and finished knitted fabrics

Sample		S_p , cm	s, %	ℓ , mm	C	m, g/m ²	m_z , g/cm ³
PKK	U	19.5 x 2	39	3.15 ± 0.02	0.97	157	0.25
	F	21.5 x 2	32	3.08 ± 0.01	0.85	162	0.27
MMR	U	20.0 x 2	37	3.14 ± 0.02	0.87	154	0.25
	F	20.5 x 2	36	3.09 ± 0.01	0.74	153	0.34
SP	U	18.0 x 2	44	3.13 ± 0.01	0.89	180	0.25
	F	21.0 x 2	34	3.05 ± 0.00	0.82	147	0.40
TAJ	U	24.0 x 2	25	3.15 ± 0.02	0.73	132	0.21
	F	21.5 x 2	33	3.12 ± 0.02	0.72	156	0.32
MOE	U	24.0 x 2	25	3.14 ± 0.02	0.74	128	0.21
	F	19.0 x 2	40	3.09 ± 0.01	0.94	170	0.34

where: U - unfinished knitted fabric, F - finished fabric, S_p - fabric width, cm, s - fabric shrinkage in course direction after removal from the machine, %, ℓ - stitch density, mm, C - coefficient of stitch density, m - fabric mass per unit area, g/m², m_z - fabric volume mass, g/cm³

Knitted fabric volume mass (m_z) was significantly higher for all analysed finished fabric samples than for the unfinished ones. For the unfinished knitted fabrics it ranged from 0.21 to 0.25 g/cm³, and for the finished ones from 0.27 to 0.40 g/cm³, i.e. it was higher by 7.2 to 38.4%. Knitted fabrics with an increased volume mass can be used for garments worn at lower temperatures [9].

5. Results and discussion of tensile properties of knitted fabrics

To measure tensile properties of knitted fabrics, 50 mm wide and 200 mm long samples were cut out. The distance between the grips of the tensile tester was 100 mm. The STATIMAT M tensile tester was used to measure unfinished and finished knitted fabric samples cut out in course and wale direction. While tensile force acts, the sample is elongated with continuous measurement of force-elongation data. In case of a break of the knitted fabric the last measurement is recorded which represents the force/elongation of the knitted fabric. After the measurements were performed, the tensile properties of knitted fabrics in course direction or transversally and in wale direction or longitudinally were studied separately. The analysis of all the results of stretching the knitted fabrics up to breakage in course direction or transversally, which ranged from 300 to 400 %, showed the percentages of the individual mentioned regions. Fig. 4 shows the force/elongation diagram of the micromodal knitted fabric (MMR) whose breaking elongation in the course direction amounted to about 320 %.

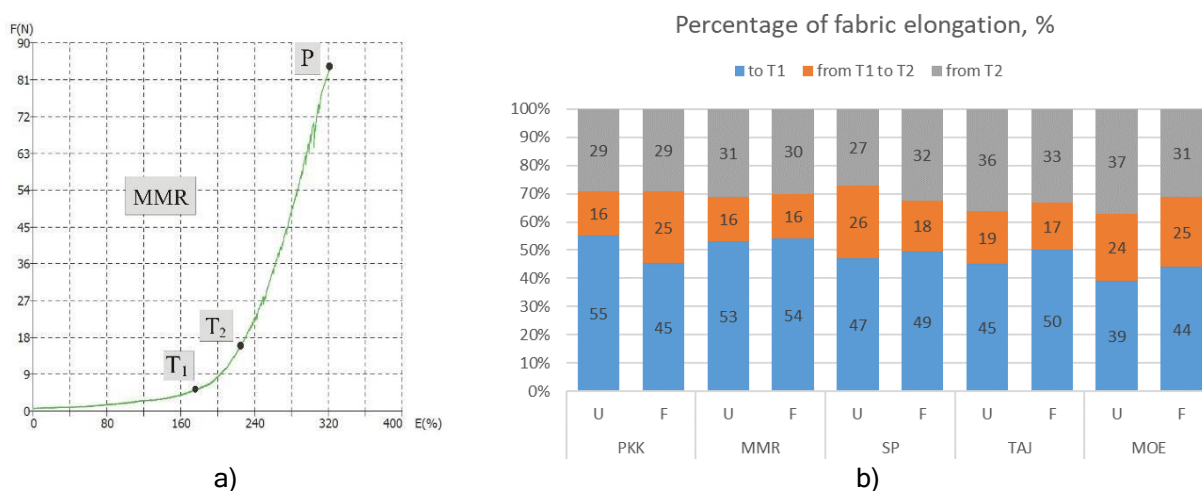

Figure 4: Elongation of the knitted fabric in the course direction - transversally; force/elongation diagram for the knitted fabric knitted of micromodal yarns spun by employing the ring spinning method (MMR), b) percentages per individual elongation regions; S – unfinished fabric, D – finished fabric

Figure 4 shows the percentages of the mentioned regions for all analysed knitted fabrics. The data were sorted according to the raw material composition of the knitted fabric. The diagram shows that the highest elasticity in the course direction was found for the unfinished cotton knitted fabric made of the yarns spun on the ring spinning machine (PKK). The percentage of elasticity amounted to 55% of the total elongation, the percentage of plasticity amounted to 29% and the rest of 16% belonged to the region between points T1 and T2. The modal knitted fabric made of the yarns spun on the rotor spinning machine (MOE) had the lowest elasticity, which accounted for 39%. For this knitted fabric sample the smallest differences were recorded among the individual percentages. The elastic region had a percentage of 39%, the elastic region had a percentage of 37% and the region between elasticity and plasticity had a percentage of 24%. The smallest difference in the tensile properties of the unfinished and finished knitted fabrics was recorded for the micromodal fabric (MMR). By finishing the knitted fabric, the percentage of the elastic region decreased for the cotton and slightly for the micromodal knitted fabrics, and increased for all other knitted fabrics.

In the production of classic underwear it is significant to observe that the percentage of elasticity ranged from 39 to 55%, and if gentle compression garment is made, the knitted fabric can be elongated from 65 to 70% in the course direction. Elongation at break of the knitted fabric in the wale direction or longitudinally ranged from 30 to 50%, and it was significantly lower than the elongation at break in the course direction, whereby the percentage of the elastic region was also lower, Fig. 5b.

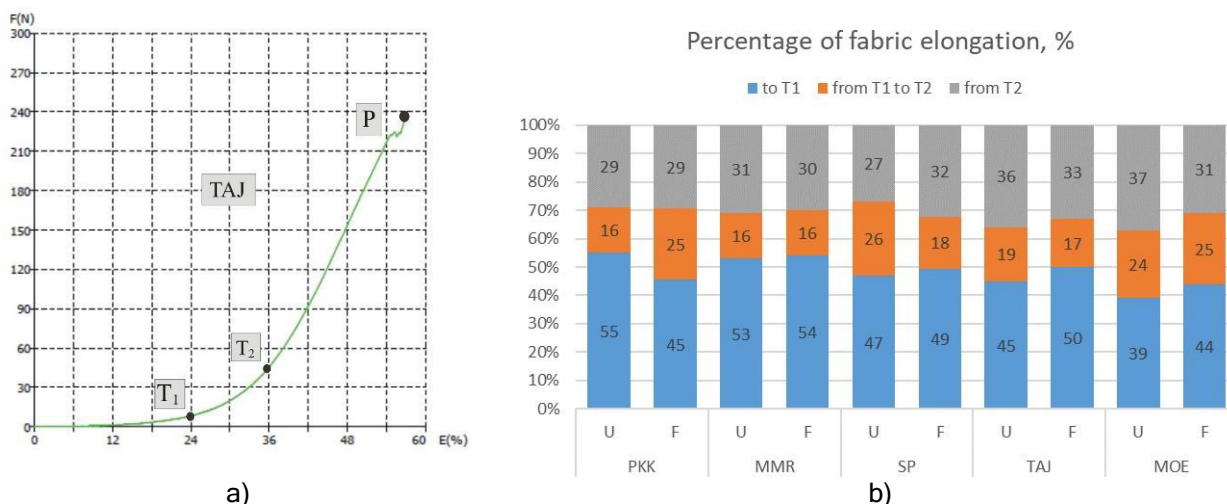

Figure 5: Elongation of the knitted fabric in the wale direction - longitudinally; a) force/elongation diagram of the knitted fabric knitted of the Lyocell (Tencel) yarns spun by employing the air-jet spinning method (TAJ), b) percentages per individual regions of elongation; S - unfinished fabric, D - finished fabric

The percentage of elasticity ranged from 21 to 41%. The lowest percentage of elasticity was recorded for the unfinished Lyocell knitted fabric (TAJ-S), amounting to 21% and the highest percentage was recorded for the micromodal knitted fabric (MMR-D), amounting to 41%. For the finished cotton (PKK) and viscose knitted fabrics (SP), the percentage of elasticity was lower than for the unfinished knitted fabrics, and it was higher for all other samples. The highest percentage of elasticity in both the finished and unfinished knitted fabrics was recorded for the micromodal yarns (MMR), and it was significantly higher than in the cotton knitted fabrics. The percentage between the end of the elastic region and the onset of plastic deformation ranged from 21 to 37%, and it was the lowest in the unfinished Lyocell knitted fabrics (TAJ-S) and the highest in the finished cotton knitted fabrics (PKK-D). The percentage elongation of the knitted fabric to the onset of permanent deformation amounted to 50% in four samples, and in the remaining six samples it ranged from 50 to 65%. During elongation of the knitted fabric in the wale direction the percentage of permanent deformation was high, ranging from 40 to 58%.

6. Conclusion

On the basis of the investigations conducted the following basic conclusions can be reached: The yarns for making samples had the same nominal count, but their tensile properties were significantly different. All the knitted fabric samples were made on one machine under the same knitting conditions. All the knitted samples were of the essentially different structure. The finishing process significantly changed the structure. The percentage of elasticity in the course and wale direction was different depending on the raw material composition of the yarn, its manufacturing process and fabric finishing. Raw material composition, yarn structure and tensile properties of the knitted fabric as well as fabric finishing caused all other differences. Particular attention should be paid to the finishing of knitted fabrics, which will be adapted to the yarns of certain structures. The research results suggest that it is relatively difficult to obtain the same knitted fabric structure with the mentioned yarns that will be used for the manufacture of one product.

Acknowledgment:

This work was funded by the Croatian Science Foundation, Project IP-2016-06-5278.

References:

- [1] Engelhardt, A. & et.: The Fiber Year 2018, *Institut fuer Textiltechnik RWTH*, Aachen (2019)
- [2] Skenderi, Z. et al: Nejednolikosti aerodinamičke pređe u usporedbi s prstenastom i rotorskom pređom od mikromodalnih vlakana, *Tekstil*, ISSN 0492-5882, 67, 1-2, pp. 1-13, (2018)
- [3] Vrljićak Z.: *Pletiva*, Tekstilno-tehnološki fakultet, ISBN 978-953-7105-79-2, Zagreb (2019)
- [4] Vrljićak Z.: *Tehnološki izračuni proizvodnje pletiva*, Tekstilno-tehnološki fakultet, ISBN 978-953-7105-69-3, Zagreb (2017)
- [5] <https://www.lenzing.com/products>, Accessed: 2020-01-20
- [6] <http://www.viloft.com>, Accessed: 2020-01-20

- [7] HRN EN ISO 13934-1; Tensile properties of fabrics - Part 1: Determination of maximum force and elongation at maximum force using the strip method
- [8] Kowalski K.: Identifikacija procesu dziania na szydelkarkach, Polska Akademia Nauk, *Oddzial w Lodzi, Komisja Wlokiennictwa*, Lodz (2008)
- [9] Pavlović, Ž. et al.: Istraživanja strukture i vlačnih svojstava desno-desnih pletiva izrađenih predama različitog sirovinskog sastava i procesa pređenja pri jednakim parametrima pletenja, *Tekstil*, ISSN 0492-5882, 66, 11-12, pp. 279-296, (2017)
- [10] Čunko R.: Ispitivanje tekstila, Sveučilište u Zagrebu, Tekstilno-tehnološki fakultet, ISBN 86-329-0180-X, Zagreb (2011)
- [11] Vrljićak Z.: Kritički osvrt na analizu parametara strukture kulirnih pletiva, *Tekstil*, ISSN 0492-5882, 48, 4, pp. 181-187 (1999)

Author(s):

mag.ing.techn.text. Željka PAVLOVIĆ (corresponding author) ; Prof. Zlatko VRLJIČAK Ph.D.
University of Zagreb Faculty of Textile technology
Prilaz baruna Filipovića 28a, 10000 Zagreb, Croatia
Phone: +(385) (01) 3712 572 E-mail: zeljka.pavlovic@ttf.unizg.hr;

THERMAL INSULATION PROPERTIES OF THE PROTECTIVE VEST TESTED ON A THERMAL MANIKIN IN STATIC MODE

Nikolina JUKL; Snježana FIRŠT ROGALE & Dubravko ROGALE

Abstract: The paper presents a test of thermal insulation of a protective vest in static mode. The vests have the same construction characteristics but differ in the raw material composition of the base fabric. Measurements were performed on a system for testing the thermal properties of clothing called thermal manikin. It is installed in the Department of Clothing Technology of the Faculty of Textile Technology. The test was performed according to the international standard ISO HRN EN ISO 15831. The obtained results were processed by statistical analysis and prove a statistically significant difference between the arithmetic means of the tested protective vests.

Keywords: thermal insulation properties, thermal manikin, protective vest, static mode

1. Introduction

Thermal comfort is defined, according to the EN ISO 7730:2008 [1] as that condition of mind that expresses satisfaction with the thermal environment. To obtain exact data on the thermal properties of clothing, it is necessary to perform measurements on measuring systems for testing the thermal properties of clothing.

Thermal manikins are anatomically shaped measuring systems used to evaluate the thermal properties of clothing. The first thermal manikin was made in the 1940s in the United States for the US military [2]. To date, more than a hundred thermal manikin have been designed worldwide, differing in size, shape, number of segments, control method and measurement method [3-6]. Thermal insulation is tested in static mode and dynamic mode. In static mode, the thermal insulation of clothing is measured when a person is standing, and in dynamic mode, a person's gait is simulated, and the limbs of the thermal model are moved. Some designs of thermal manikins have a realized possibility of simulating sweating. The measurement results on thermal manikins are reliable and accurate [7]. Currently, thermal manikins are mostly used in research laboratories, but their application for testing thermal insulation in the apparel industry, especially for work and protective clothing, in order to produce clothing with specific thermal insulation properties has also begun [2-4, 7].

2. Materials and methods

Testing of thermal insulation of two protective vests in static mode, which have the same constructional characteristics, but differ in the raw material composition of the base fabric were carried out. For the purposes of this paper, two protective vests of clothing size 52 were made. Table 1 shows the appearance of the vest and provides data on the raw material composition.

Table 1: The basic characteristics of the examined models

Model design		Raw material composition of the models	
		Base fabric	Lining fabric
Model 1		50% cotton 50% polyester	100% viscose
Model 2		50% cotton 50% polyamide	

Measurements were performed on a thermal manikin constructed and installed at the University of Zagreb Faculty of Textile Technology, Figure 1. The mentioned thermal manikin consists of 24 segments within which electric heaters, temperature sensors, microcontroller assembly and pneumatic system for moving arms and

legs are installed [8,9]. Determination of thermal properties takes place at the time of establishing thermal equilibrium [2] and according to the international standard HRN EN ISO 15831: 2005. The mentioned standard describes the necessary names and definitions of terms used in measuring the thermal insulation of clothing systems. It also defines the principle of operation of the measuring system and the requirements related to the thermal manikin (clothing size, anatomical features, surface), heating and power measurement system, climate chamber, air temperature monitoring sensor, relative humidity monitoring sensor and air flow rate monitoring. The selection and preparation of clothing that will be tested is also described. The thermal insulation of the garment system thus measured becomes applicable to the wearer in practical use in a relatively calm environment with the wearer either standing or moving [7, 9-11].



Figure 1: Thermal manikin installed at the Faculty of Textile Technology

Before starting the measurement, a calibration measurement must be performed, which means that the total thermal resistance of the empty surface of the thermal manikin together with the boundary layer of air along the surface of the manikin's body must be defined. When stable environmental conditions are established, the so-called thermal manikin constant R_{ct0} , which is determined by the following expression, is determined:

$$R_{ct0} = \frac{(T_s - T_a) \cdot A}{H_0} \quad (1)$$

where is:

R_{ct0} - the total thermal resistance of the empty surface of the measuring device together with the boundary layer of air along the surface, [$m^2 \text{ } ^\circ\text{C W}^{-1}$]

A - total body surface area of the manikin, [m^2]

T_s - skin surface temperature of the body segment i of the manikin, [$^\circ\text{C}$]

T_a - air temperature within the climatic chamber, [$^\circ\text{C}$]

H_0 - heating power supplied to the body segment i of the manikin, [W]

After determining the constant R_{ct0} , the selected garment is put on the thermal manikin and the operation of the device is monitored until a new thermal balance is reached. After reaching equilibrium, which can be seen by stabilizing the values of the parameters (numerically and through diagrams), a series of measurements and calculations of thermal resistance (R_{ct}) of sample should be performed according to the expression:

$$R_{ct} = \frac{(T_a - T_s) \cdot A}{H_m} - R_{ct0} \quad (2)$$

where is:

H_m - heating power supplied required to maintain the temperature of the measuring surface on which the measuring sample is located, [W]

3. Results

The thermal insulation properties of the two protective vests were tested on a thermal manikin. Before testing the thermal insulation properties of protective vests, the total heat transfer resistance of the empty surface of the measuring device together with the boundary layer of air along the surface of the manikin's body was defined. It amounted to 0.097215 m²KW⁻¹. The measurements were performed in an air chamber at an ambient air temperature of 20 °C, a body surface temperature of the thermal manikin of 34 °C and an air flow rate of 0.4 ms⁻¹. The relative humidity was 50%. Table 2 shows the measurement results.

Table 2: Test results of thermal insulation properties of protective vests

	Model 1 [m ² KW ⁻¹]	Model 2 [m ² KW ⁻¹]
1.	0,0302	0.014502
2.	0.030211	0.027219
3.	0.021589	0.024693
4.	0.026485	0.016889
5.	0.025032	0.02015
6.	0.031776	0.026713
7.	0.025923	0.022462
8.	0.023618	0.011723
9.	0.029137	0.030935
10.	0.024971	0.026703
11.	0.027781	0.010274
12.	0.029904	0.025626
13.	0.019173	0.02713
14.	0.025994	0.013341
15.	0.032488	0.019016
16.	0.025676	0.03273
17.	0,022064	0,018726
18.	0,025451	0,007935
19.	0,02939	0,028964
20.	0,021889	0,033393
average	0,0264376	0,0219562

After testing, statistical analysis of the obtained data was performed, Table 3. One-way (one-way) analysis of ANOVA variance, with a significance level of $\alpha = 0.05$ was used.

Table 3: Results of statistical comparison of the results of measuring the thermal insulation properties of protective vests

SUMMARY

Groups	Count	Sum	Average	Variance
Model 1 [m ² KW ⁻¹]	20	0.528752	0.026438	1.33431E-05
Model 2 [m ² KW ⁻¹]	20	0.439124	0.021956	5.85806E-05

ANOVA

Source of Variation	SS	df	MS	F	P-value	F crit
Between Groups	0.000200829	1	0.000201	5.584508772	0.02333927	4.098172
Within Groups	0.001366552	38	3.6E-05			
Total	0.001567381	39				

$P < \alpha (0, 05) =$ there are statistically significant differences between the arithmetic means of the observed samples

4. Conclusion

Statistical analysis proved that there are statistically significant differences between the arithmetic means of the observed samples and that Model 1 has better thermal insulation properties than Model 2. The conclusion as to why Model 1 has better thermal insulation lies in the material composition of the base fabric of the models, giving the fact that both models have the same constructional characteristics, but differ in the raw material composition of the base fabric. Based on the conducted measurements we can conclude that the material composition that contains polyester ensures better thermal insulation of clothing. That implies that polyester has better thermal resistance properties than polyamide, but further measurements are recommended because of the complexity of the fabric properties and its influence on thermal insulation of clothing systems.

Acknowledgements



This paper was written within the Research project HRZZ IP-2018-01-6363: Development and thermal properties of intelligent clothing funded by the Croatian Science Foundation

References

- [1] ISO 7730:2005: Ergonomics of the thermal environment — Analytical determination and interpretation of thermal comfort using calculation of the PMV and PPD indices and local thermal comfort criteria
- [2] Holmér I.: Thermal manikin history and applications, *European Journal of Applied Physiology*, **92**, (2004), 6, 614-618, ISSN: 1439-6319
- [3] Rogale D., Majstorović G. & Firšt Rogale S.: Comparative Analysis of the Thermal Insulation of Multi-Layer Thermal Inserts in a Protective Jacket, *Materials* **13**, (2020), 12, 1-13, ISSN: 1996-1944
- [4] Pamuk O.: Thermal manikins: an overview, *e-Journal of New World Sciences Academy*, **3**, 1, Article Number: A0057, ISSN: 1306 3111 (2008)
- [5] Fojtlín M., Fišer J., Jícha M. (2015): Repeated determination of convective and radiative heat transfer coefficients using 32 zones thermal manikin, *Extreme Physiology & Medicine*, (4) 1, 160
- [6] Voelker C., Maempel S., Kornadt O. (2014): Measuring the human body's microclimate using a thermal manikin, *Indoor Air*, (24) 6, 567-579
- [7] Holmér I.: Thermal manikins in research and standards, *Proceedings of the Third International Meeting on Thermal Manikin Testing 3IMM at the National Institute for Working Life*, Nilsson (Ed.), 4-9, ISBN, Stockholm, October 2000, National Institute for Working Life, Stockholm
- [8] Rogale D., Firšt Rogale S., Špelić I. (2014): Development of the Measuring System for Analysing the Thermal Properties of Clothing, *Book of Proceedings of the 7th International Textile, Clothing & Design Conference 2014 – Magic World of Textiles*, Dubrovnik, Croatia, 322-327, ISSN 1847-7275, ISBN 978-953-7105-54-9
- [9] Firšt Rogale S., Benić M., Rogale D. (2017): Istraživanje otpornosti prolasku topline različitih kombinacija muške odjeće, *Zbornik radova 10. znanstveno-stručnog savjetovanja Tekstilna znanost i gospodarstvo*, Martinia Ira Glogar (ur.), Zagreb, Sveučilište u Zagrebu Tekstilno-tehnološki fakultet, 43-48
- [10] Fan J.: Simulation of perspiration in sweating fabric manikin-Walter, *WIT Transactions on Ecology and the Environment*, **87**. (2006) 5, 221-230, ISSN 1743-3541
- [11] EN ISO 15831: Clothing - Physiological effects - Measurement of thermal insulation by means of a thermal manikin.

Authors:

Nikolina JUKL*, mag.ing. tex. tech. (corresponding author)
prof. dr. sc. Snježana FIRŠT ROGALE
prof. dr. sc. Dubravko ROGALE

University of Zagreb Faculty of Textile Technology**
Prilaz baruna Filipovića 28a, 10000 Zagreb, Hrvatska
Phone: +(385) (1) 3712553 Fax: +(385) (1) 3712599

E-mail: jukl.nikolina@gmail.com;
E-mail: sfrogale@ttf.hr;
E-mail: dubravko.rogale@ttf.hr;

A REVIEW OF RIGID 3D REGISTRATION METHODS

David BOJANIĆ; Kristijan BARTOL; Tomislav PETKOVIĆ; Tomislav PRIBANIĆ

Abstract: 3D registration is a process of aligning multiple three dimensional (3D) data structures (such as point clouds or meshes) and merging them into one consistent and seamless 3D data structure. With the scope of 3D reconstruction, 3D human body scans from multiple views need to be registered into a single point cloud to create a seamless 3D representation. In this work, we provide an overview of rigid 3D registration methods as well as a breakdown of the different parts of its process, namely, detection, description, and matching (if available). We describe the motivation behind the process and explain in detail the different used approaches in determining the aligning transformation.

Keywords: 3D computer vision, 3D registration, keypoint detection, keypoint description, keypoint matching

1. Introduction

3D registration is a fundamental problem in computer and robot vision. Given two 3D structures (usually represented as a set of points) in different coordinate systems, or equivalently in the same coordinate system with different poses, the goal is to find the transformation that best aligns one structure to the other. It arises as a subtask in many different vision applications such as: 3D reconstruction [1,2,3], object recognition and categorization [4,5,6], shape retrieval [7], robot navigation [8,9] and data fusion obtained from different sensors [10]. Fig 1. shows two 3D structures obtained from two different viewpoints of the same object that, when registered, merge into one seamless and coherent object.

Even though some of these problems might be solved using hardware solutions [11] such as calibrated mechanics (e.g. movable robot arms) aware of their positional displacement, the applicability of such solutions is poor. Furthermore, problems such as object recognition, still require software solutions, thus making 3D registration a prominent research field.

Whereas this paper focuses on rigid registration, where we assume a fixed rigid environment, there are approaches [12] that tackle the more general non-rigid registration problem in which articulated objects and soft bodies that can change shape over time might be present.

3D registration methods are classified in two different categories: coarse and fine registration [13]. The former encompasses all techniques that return a rough initial alignment of the given 3D structures, without any given initial alignment. The latter starts from one such approximation and aims at finding a registration as accurate as possible.



Figure 1: Example of partial registration of two point clouds.

2. Data representation

Each of the many applications that use registration techniques has its preferred data representation type. The most commonly used one in the literature are point clouds, followed by meshes and volumetric data. The former is a collection of 3D points with no further information. The second is composed of a point cloud and additional connectivity information between points, usually represented as a graph. The most commonly used format are triangular meshes where the graph edges form triangles. Volumetric data is often used in medical imaging (e.g. MRI) due to the nature of acquisition, and is represented by an isotropic set of samples taken at regularly spaced intervals along three orthogonal axes. The values represent some measurable property of the data like colour, density or heat to name a few. In the next chapters we focus on point clouds and meshes.

3. 3D Transformations

A rigid 3D rigid-body transformation can be represented in several ways. The core elements of the transformation are a rotational component R and a translational component t which, obviously, rotate and translate the 3D object in hand.

The rotational component R is a 3x3 matrix from the special orthogonal group $SO(3)$, also called the rotation group, which contains all 3x3 orthogonal matrices having determinant equal to 1. The orthogonality condition is necessary because the rotation connects two coordinate systems while the unit determinant condition follows from the orthogonality condition and preservation of the "handedness" of the coordinate system. More intuitively, the rotation matrix R can be further divided into three matrices representing the rotation around each of the three axes x , y and z by the angles α , β and γ in the following way:

$$R = R_z(\gamma)R_y(\beta)R_x(\alpha) \quad (1)$$

where:

$$R_z(\gamma) = \begin{bmatrix} \cos(\gamma) & -\sin(\gamma) & 0 \\ \sin(\gamma) & \cos(\gamma) & 0 \\ 0 & 0 & 1 \end{bmatrix}, R_y(\beta) = \begin{bmatrix} \cos(\beta) & 0 & \sin(\beta) \\ 0 & 1 & 0 \\ -\sin(\beta) & 0 & \cos(\beta) \end{bmatrix}, R_x(\alpha) = \begin{bmatrix} 1 & 0 & 0 \\ 0 & \cos(\alpha) & -\sin(\alpha) \\ 0 & \sin(\alpha) & \cos(\alpha) \end{bmatrix}. \quad (2)$$

This representation indicates that there are only 3 degrees of freedom (DOF) when determining a rotation matrix as opposed to 9 when looking at the matrix as an element of the $SO(3)$ group.

The translational component t is a 3x1 vector from R^3 and has 3 DOF as well. Consequently, in combination with a rotation, the rigid transformation has 6 DOF.

If $p = [x, y, z]^T$ is a point in space, then a rigid transformation can be written in matrix form as:

$$p' = R \cdot p + t \quad (3)$$

where \cdot represents matrix multiplication and $p' = [x', y', z']^T$ is the transformed point.

We can combine the rotation and translation matrices to form a more compact representation of the rigid transformation using homogeneous coordinates. Homogeneous coordinates are usually used in projective geometry and offer a simplified way of combining transformations using only matrix multiplications. They extend 3D points $[x, y, z]^T$ with equivalence classes $[kx, ky, kz, k]^T$ which represent the same point for any $k \in R \setminus 0$. Now, the transformation is as a 4x4 matrix from the special Euclidean group $SE(3)$ with the form:

$$T = \begin{bmatrix} R & t \\ 0 & 0 & 0 & 1 \end{bmatrix} \quad (4)$$

where again $R \in SO(3)$ and $t \in R^3$.

If $p = [x, y, z, 1]^T$ is a homogeneous representation of a point in space, the rigid transformation now takes form:

$$p' = T \cdot p \quad (5)$$

where again \cdot is the matrix multiplication and p' is the new transformed point in homogeneous coordinates. Both $SO(3)$ and $SE(3)$ are Lie groups with their appropriate Lie algebras $so(3)$ and $se(3)$. An exponential map connects these two structures and allows us to represent a transformation matrix $T \in SE(3)$ as an element of the $se(3)$ algebra as so:

$$T = \exp(\sum_i \varepsilon_i T_i) \quad (6)$$

where T_i are the generators of the exponential map with twist parameters $\varepsilon \in R^6$. Now, the rigid transformation takes the same form as equation (5).

There exist other transformation representations, such as quaternions, but are rarely used in the context of 3D registration and are hence not relevant to our discussion.

4. Problem Formulation

As we've seen, the registration problem comes down to finding the rotation R and translation t matrices that best align the two point clouds. The problem can be approached by defining a cost function that represents the current error, and indicates how well the two point clouds overlap. This cost function is then minimized using common optimization techniques. The most common cost function is the L2 norm of the point cloud displacements.

Let $X = \{x_i\}_{i=1}^N$ be the source and $Y = \{y_j\}_{j=1}^M$ the target point clouds that need to be registered. Usually this terminology indicates that we are searching for a transformation of the target point cloud Y that registers it to the source X .

Let

$$C = \{(x_i, y_j) | x_i \in X, y_j \in Y \text{ holding } \forall y_k \in Y d(x_i, y_j) < d(x_i, y_k) \text{ and } d(x_i, y_j) < thr\} \quad (7)$$

be a set of correspondences between points from X and Y where $d(\cdot, \cdot)$ is the Euclidean distance and thr is a threshold that discards distances larger than it, as to omit larger errors when dealing with partial registration. As opposed to full registration, where all the points from the source point cloud have a match in the target point cloud, partial matching assumes only some points are correspondent (as is the more typical case). Fig. 1 shows one such example. Then, the registration problem can be written as a minimization problem:

$$\min_{R,t} \sum_{(x_i, y_j) \in C} \|R \cdot x_i + t - y_j\|_2^2 \quad (8)$$

Here, the set C was determined as the points from both clouds that have the smallest distance to one another which is a technique usually used in fine matching rather than coarse matching. More generally, the set C can be determined in many alternative ways as we'll see in later chapters. In practice, the correspondences are unknown which makes (8) a classic "chicken-and-egg" problem: if the correspondences are known, R and t can be easily found; if R and t are known, the correspondences are easily derived.

To conquer this, some methods interchangeably search for the correspondences and transformation. Most of them, however, focus on finding reliable correspondences after which the transformation is derived.

If C is the set of correspondences, (8) has a closed form solution:

$$R = VU^T, t = -R\bar{x} + \bar{y} \quad (9)$$

where U and V are obtained using the singular value decomposition (SVD) $H = USV^T$ of the covariance matrix

$$H = \sum_{(x_i, y_j) \in C} c(x_i - \bar{x})(y_j - \bar{y})^T \quad (10)$$

and centroids

$$\bar{x} = \frac{1}{N} \sum_{i=1}^N x_i, \bar{y} = \frac{1}{M} \sum_{j=1}^M y_j \quad (11)$$

More intuitively, the process is similar to the principal component analysis (PCA) and extracts the major directions of shared change from the origin centered point clouds.

As said before, there are two approaches towards solving (8). One is to first determine the correspondences and use them along with (9). We denominate this approach as *detection-description-matching* as the three major components of the pipeline. The second method is to try and solve directly for R and t in various methods. We denominate this approach as *all-in-one* since they cannot be broken down into the detection-description-matching pipeline.

4.1 Detection-description-matching

In this approach, a detection step is firstly used to reduce the number of points being considered in the registration process. It consists of detecting a certain number of key points that are prominent according to a specific criterion. The sizes of the input data make the detection step necessary in many approaches to obtain computationally manageable datasets. The second step of the pipeline, description, consists of assigning values to the detected key points according to the local shape around them. Finally, searching strategies are used to find correspondences between points in the two point sets. Descriptor values are used to prioritize the best apparent correspondences and a minimum of three are needed to determine the coarse alignment in 3D. The goal here is to avoid exhaustive search of the whole correspondence space which would yield a cost of $O(n^6)$ since triplets from both clouds need to be checked.

After achieving a coarse alignment, a refinement step is applied. This step usually consists of using iterative methods to align the shapes as accurately as possible.

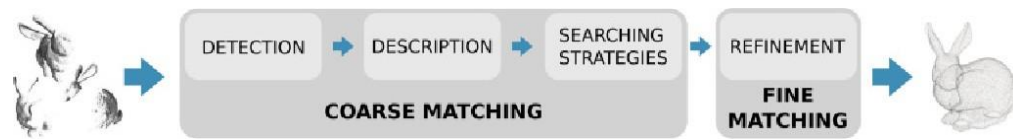

Figure 2: Pipeline of the detection-description-matching approach. Taken from [13].

Detection is a crucial step in the optimization of the whole pipeline. A good detector should be computationally efficient and should extract repeatable and distinctive key points under a number of nuisances that can affect the input data, like for example viewpoint changes, missing parts, point density, clutter and sensor noise [14,15]. Repeatability is the capability to detect the same keypoints accurately under various nuisances, whilst distinctivity is the ability to detect keypoints that can be effectively described and matched, to prevent wrong point-to-point correspondences.

Following evaluation papers and algorithm comparisons [13-17], some of the most promising hand-crafted detectors are: ISS [18], MeshDoG [19], Harris 3D [20] and HKS [21]. ISS uses eigen decomposition of the neighbourhood's covariance matrix of a point to describe it. Keypoints are selected as the points with large three dimensional variations in their neighbourhood. These variations are measured using the smallest eigenvalue of the covariance matrix of its spherical neighbourhood. MeshDoG is based on the Difference of Gaussians (DoG) operator. It finds the extrema of the Laplacian of a scale-space representation of any scalar function defined on a discrete manifold. Harris 3D is a 3D version of the Harris operator which is applied on a 2D projection of the points, without losing relevant information. The point set is rotated and translated according to the centroid of the neighbourhood around a point with the goal of finding the best projection. Finally, HKS, both a detector and descriptor, detects mesh zones with high curvatures and uses the points with the highest curvatures as keypoints. This results in very repeatable keypoints.

On the deep learning side in Salti et al. [16] use random forests to learn the best keypoint detector for a hand-crafted descriptor as to improve the final step of the pipeline, matching. Their method betters the matching of three distinct descriptors, namely SHOT [4], FPFH [22] and Spin Images [6], but can be trained for any descriptor. Lin et al. [17] formulate 3D keypoint detection as a regression problem using deep neural networks with sparse autoencoders. The model makes use of both local and global information of a 3D mesh in multi-scale space to detect whether a vertex is a keypoint or not. Suwajanakorn et al. [23] introduce KeypointNet which tries to learn an optimal set of category-specific 3D keypoints; more concretely it tries to learn a list of 3D keypoints on both views that would result in the best matching of the point clouds. This pose estimation objective helps significantly in producing a reasonable and natural selection of latent keypoints.

Descriptors are sets of values that represent the contained geometric and spatial information within the local surface. These descriptors can be classified by the fact if they are based on a local reference frame (LRF) or just the local geometry. LRF is an independent 3D coordinate system from the world coordinate system that is established on the local surface. The goal of a LRF is mainly to make the feature description invariant to rigid transformation. LRF based methods have generally surpassed LRF-independent ones on most publicly available datasets [24]. Some LRF based methods are SHOT [4], RoPS [5] and LoVS [25]. SHOT divides the local 3D volume into a set of subspaces and concatenates the histograms of normal deviation in each subspace as the final feature representation. RoPS proposes a *rotation and projection* mechanism that continually rotates the local surface with respect to the LRF and performs 3D-to-2D projections for each rotated surface. The eventual feature is the integration of the statistical information of the projected maps. LoVS uses a cubic volume to determine the local surface and performs a uniform spatial partition to generate voxels. Each voxel is encoded by a binary code to judge whether the voxel is empty or not.

Some LRF-independent methods are Spin Images (SI) [6], Point feature histogram (PFH) [26] and Fast PFH (FPFH) [22]. Spin Images projects the neighbouring points of a keypoint on a 2D plane by calculating their horizontal and vertical distances with respect to the tangent plane of the keypoint normal, and the ratio of points in each 2D grid is taken as the bin value. PFH and FPFH leverage the point pair features extracted from the local surface to generate statistical histograms, where PFH considers all possible points but FPFH speeds up the procedure by requiring each point pair to include the keypoint.

There are deep learning based descriptors as well, such as: PointNet [27], 3DMatch [28], CGF [29], PPFNet [30], PPF-FoldNet [31] and 3DFeat-Net [32]. Deep learning descriptors have surpassed many hand-crafted

local geometric descriptors. Nevertheless, the majority of learned descriptors from raw data suffer from sensitivity to rotation. An effective solution is to first use traditional feature descriptors for parametrization and then employ convolutional neural networks to further boost the performance.

PointNet is a pioneer in designing a permutation invariant network which doesn't use voxelized inputs but rather point clouds. 3DMatch is a learning based representation that uses truncated distance function (TDF) to parametrize input local patches and learns the feature representation using a Siamese network paired with a metric learning network. PPFNet employs the point pair features between the keypoint and its neighbors to encode the raw local point cloud and proposes an N-branch network for feature learning. PPF-FoldNet further improves PPFNet by leveraging rotational invariant point pair features and uses a point cloud auto-encoder network to achieve unsupervised feature learning.

Once the point clouds have been filtered (keypoints have been detected) and described, in order to solve the registration problem, the correspondences are needed. Rather than using brute-force methods which are computationally expensive, we strive for more elaborate algorithms in order to report results in a reasonable amount of time. This is where searching (matching) algorithms take over. Following [33,34], the state-of-the-art methods for finding correspondences are geometric consistency (GC) [35], 3D Hough Voting (3DHV) [36] and game theory matching (GTM) [37].

For an initial set of correspondences C as in (7), the goal is to find a set of inlier points that truly are matches. GC determines the inlier set by finding the largest cluster formed by calculating compatibility score of a single correspondence with all the other correspondences. The compatibility score is a thresholded absolute difference between the distance of the correspondence points. In 3DHV, each correspondence casts a vote in a 3D Hough space. It finds the vectors from the correspondent points to its appropriate centroids, and transforms them into their appropriate LRFs. If the points truly do match, these vectors should be equal. GTM interprets the correspondence grouping as a non-cooperative game. Candidates in the initial correspondence set C are treated as available strategies. Pairs of players play a symmetric game and adapt their behaviour to prefer strategies that receive larger payoffs. Eventually such dynamics converge to a Nash equilibrium.

4.2 All-in-one approaches

In this chapter we present approaches that cannot be separated into the detection-description-matching pipeline as the approaches before. There are several methods [38] that take completely different approaches of finding the optimal transformation. 4-point congruent sets (4PCS) [39] is a global registration algorithm. The global optimality references the finding of the global minima when solving (8). The goal of 4PCS is to find the best aligning transformation according to the largest common point set (LCP) between the source X and target Y point clouds. The LCP of a rigid transformation is the cardinality of the largest subset of the transformed source point cloud X , with the property that every point in the subset is within an ϵ distance to Y . The method is based on efficiently finding the set of congruent 4-point bases in the source point cloud X , to a 4-point base selected from the target point cloud Y .

A set of 4 coplanar points is selected from X , $S = \{a,b,c,d\}$, not all collinear, such that ab intersects cd at the intermediate point e . Given a 4-point base constructed from two intersecting pairs, two ratios can be defined:

$$r_1 = \|a - e\|/\|a - b\|, \quad r_2 = \|c - e\|/\|c - d\| \quad (12)$$

These ratios are preserved under affine transformations and therefore act as invariants to constrain the search for congruent 4-point bases in X . Under rigid transformations, distances are also preserved and therefore the distances of the two pairs, d_1 and d_2 , are also used as invariants. The runtime complexity of the algorithm is $O(N^2 + k)$ where N is the number of points in X and k is the number of congruent bases to be reported. Generalized 4PCS [40] generalizes 4PCS by allowing the pairs to fall on two different planes which have an arbitrary distance between them. This separation exponentially decreases the search space of matching bases. 4PCS presents two bottlenecks: the extractions of congruent pairs from X and the verification of the large number of reported congruent sets. By addressing these bottlenecks, Super 4PCS [41] improves the total runtime complexity to $O(n+k_1+k_2)$ where k_1 is the number of pairs of a given distance, and k_2 is the number of congruent bases. In order to extract pairs efficiently, X is organized using a 3D grid. A regular splitting strategy, like the one used for an octree, is applied to the 3D grid. Using the 3D grid, for each point p from X , the cubes that intersect the spheres of radius d_1 and d_2 centered at p are computed to form the pairs. To address the second bottleneck, the search is constrained to searching source bases that have the same angle of intersection as the target base, since angles are preserved under rigid transformation. Lastly, Super Generalized 4PCS [42] combines the two solutions.

A completely different approach is done by PointNetLK [43] which tries to utilize the classical Lucas & Kanade (LK) algorithm [44]. PointNetLK uniquely uses the Lie algebra $se(3)$ representation of the transformation matrix, as shown in (6), that needs to be found between the PointNet embeddings of the source and target point clouds. With the inverse compositional formulation of the problem, linearization, and approximation of the Jacobian matrix of the linearization process with finite differences (that only need to be computed once), PointNetLK iteratively updates the transformation matrix that it searches for. This process exhibits great efficiency since the only calculation in each iteration is the difference of the embedded point clouds. DeepICP [45] is an end-to-end learning-based point cloud registration framework. The algorithm firstly extracts feature descriptors from both the point clouds using PointNet++ [46]. After that, a point weighting layer is executed to learn the saliency of each point. Ideally, points with invariant and distinct features on static objects should have higher weights. The most significant K points are selected as the keypoints. Next a deep feature embedding (DFE) layer is applied to learn even more detailed keypoint descriptions that can better represent their geometric characteristics. More concretely, a smaller PointNet, denominated mini-PointNet, network is applied for extracting those features. After that, a corresponding point generation (CGP) layer is applied to generate correspondences from the extracted features. The alignment is generated from (9). Admittedly, the algorithm resembles a more complex approach from the *detection-description-matching* pipeline since the layers can be observed as detection, description and matching layers. Nevertheless, since the method offers an end-to-end process, it makes more sense to describe it as such, and not split the different parts in different sections.

Deep Closest Point [47] is another end-to-end deep learning framework that could potentially be classified as a *detection-description-matching* approach since the various components of the algorithm resemble approaches from that group. The algorithm firstly embeds the point clouds using PointNet or DGCNN [48]. Next, they encode contextual information using an attention-based module that modifies the embeddings taking into consideration all of the information gathered from the source and target point clouds. The correspondences are generated using a softmax function over the matrix product of the point cloud embeddings. Iterative Matching Point [49] is a very similar approach to DCP, with the biggest difference being that it wraps the whole algorithm in an iterative process. Every iteration then inputs the newly updated transformed point clouds which allows for more refined transformation results.

PRNET [50] is a sequential decision-making framework designed to solve a broad class of registration problems. As in DCP, the network embeds points using PointNet or DGCNN after which it selects keypoints as the ones with the greatest L2 norms. The correspondence is generated using a combination of (14) and the softmax solution from DCP. The reason being that (14) offers a sharp keypoint matching at the cost of non-differentiability, whereas softmax offers a "blurred" keypoint matching at the cost of the matches not being resolute. Hence, they use a Gumbel-Softmax [51] approach to sample a matching matrix. Here, a "blurring" parameter is added to use a softer matching in the beginning of the training, to a more sharp matching at the end. From there, the alignment is easily determined. PRNet is designed to be iterative, and the process above is repeated multiple times using the newly transformed point cloud with the approximation of the alignment. PCRNet [52] uses PointNet in a Siamese architecture to encode the shape information of a source and target point clouds into feature vectors. Next it concatenates those representations and uses a fully connected layer to estimate the transformation matrix. The whole approach is wrapped in an iterative component that in each iteration tries to align the target to the newly aligned source point cloud.

After two point clouds have been coarsely matched, the alignment can further be refined by fine registration. The goal in fine registration is to align the two point clouds as best as possible given the initial conditions calculated by the coarse registration algorithm. Here, Iterative Closest Point (ICP) [53] is the go-to method. Even though the algorithm has problems with wrong local minima solutions, it is still one of the most famous and used algorithms today since its conception in 1992. Very similarly to (7) and (8), ICP tries to minimize the point-to-point distances between the clouds:

$$E(R, t) = \sum_{i=1}^N e_i(R, t)^2 = \min_{R, t} \sum_{(x_i, y_j) \in C} \|R \cdot x_i + t - y_j\|_2^2 \quad (13)$$

Where $e_i(R, t)$ is the per-point residual error for x_i . Given R and t, the point y_j from Y is denoted as the optimal correspondence of x_i , which is the closest point to the transformed x_i from Y, i.e.

$$j^* = \underset{j \in \{1, \dots, M\}}{\operatorname{argmin}} \|R \cdot x_i + t - y_j\|_2^2. \quad (14)$$

Again, these equations pose an chicken-and-egg problem: if the true correspondences are known a priori, the transformation can be optimally solved in closed form (9); if the optimal transformation is given, correspondences can also be readily found. However, the joint problem cannot be trivially solved. Hence, given

an initial transformation (R,t) , ICP iteratively solves the problem by alternating between estimating the transformation with (13), and finding closest-point matches with (14). However, since (13) is non-convex, there is no guarantee that ICP will reach a global optimum.

Another issue with point-to-point distance is that the correspondence of a given point in the first cloud may not exist in the second cloud because of the limited number of points acquired by the sensor. Point-to-plane ICP tries to address this issue using the distance between a point and a planar approximation of the surface at the corresponding point. More concretely point-to-plane minimizes:

$$\operatorname{argmin}_{R,t} \sum_i \| (R \cdot x_i + t - y_j) \cdot n_j \|^2. \quad (15)$$

where n_j is the surface normal in point y_j . When the initial position of the data is close to the model, and when the input has relatively low noise, ICP with the point-to-plane error metric has faster convergence than the point-to-point version.

Many other variants of ICP [54] have been proposed that try and solve its drawbacks. Gelfand et al. [55] try to improve the efficiency and quality of the algorithm by introducing a sampling method of the point clouds. If too many points are chosen from featureless regions of the data, the algorithm converges slowly, finds the wrong pose, or even diverges, especially in the presence of noise or miscalibration in the input data. Hence, they try different cloud sampling methods such as uniform, random and normal-space sampling. They conclude that covariance sampling gives the best results along with the fastest convergence. Other than the point-to-point and point-to-plane methods mentioned before, there are other proposed variants to determine the matches. The point-to-projection [56] approach finds the correspondence of a source control point by projecting it onto a target surface from the point of view of the target. Combinations of point-to-projection and point-to-plane approaches have also been explored [57].

The proposed variants can still create mismatches. By rejecting point pairs using a threshold and reserving only the points with the smallest distances, the algorithm becomes more robust. Other criteria to remove mismatches include geometric properties and invariance of data, such as normal consistency and reciprocal correspondence.

Nevertheless, most ICP variants, as well as ICP, have a few fundamental drawbacks and because of these reasons, Yang et al. propose GO-ICP [58] which was the first globally optimal algorithm that performed rigid registration. The algorithm parametrizes the rotation by using a solid radius- π ball in R^3 with the angle-axis representation. It parametrizes the translation with a bounded cube $[-\varepsilon, \varepsilon]^3$. The algorithm uses the branch-and-bound (BnB) method to repeatedly search the space of $SE(3)$. Whenever a better solution is found, it calls the ICP algorithm initialized at this solution to refine the objective function value. Next, it uses the ICP result as an updated upper bound and continues the BnB search. The procedure is repeated until convergence. Fig. 3 shows how the BnB and ICP methods complement each other to find a globally optimal solution.

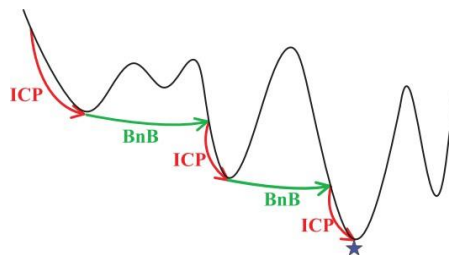

Figure 3: Alternation of the BnB and ICP for global optimality [58].

Other than ICP, there are other fine matching algorithms that are based on random sample consensus (RANSAC) [59], normal distribution transform methods (NDT), genetic algorithms or usage of auxiliary data along with the point clouds. RANSAC [60,61,62] methods involve three steps: find 3 correspondences by some heuristic, find the alignment of the point clouds with these 3 correspondences and finally count the number of inliers (points between two clouds that are within a threshold distance). The quality of every choice of 3 correspondences can be measured using the number of inliers. The more inliers a choice has, the more trustworthy is the alignment.

NDT was originally developed in the context of 2D laser scan registration [63]. The algorithm represents the observed range points as a set of Gaussian probability distributions. Assuming the point clouds have been drawn from a Gaussian distribution, the maximum-likelihood estimates of the mean and covariance can be

obtained from the observations. The fitness of the Gaussian distribution might not be good for the entire point cloud since generally there is no reason a surface should behave normally. Nevertheless, at a sufficiently small scale, a normal distribution can be considered a good estimate of the local surface shape. Therefore, the basic principle of NDT is to represent space using a set of Gaussian probability distributions.

The point-to-distribution (P2D) variant of NDT for 3D registration [64] maximises the likelihood of points from one scan, given the NDT model created from the source scan X , whilst the distribution-to-distribution (D2D) variant of NDT [65] minimizes the sum of L2 distances between pairs of Gaussian distributions in two NDT models. The NDT algorithms have fast computational speed and high precision. They are especially suitable for processing large-scale point clouds. However, initialization requirements still remain high.

5. Conclusion

This paper presented the 3D registration process and the most prominent techniques currently present in the literature. The different used data types have been presented, as well as the different transformation representations. The approaches have been classified in two different categories: *detection-description-matching* and *all-in-one*. The former use detectors to filter the number of points, descriptors to describe the remaining points and "matchers" to find correspondences from which the rigid transformation can be estimated. The latter try to approximate the transformation directly. The approaches have also been classified to coarse and fine registration methods. The former roughly align the point clouds without any initial requirements, while the latter need an already good estimation of the transformation to further improve the alignment. The approaches have also been labelled as hand-crafted or deep learning approaches depending on the algorithm.

Acknowledgement

This research has been (partly) supported by the European Regional Development Fund under the grant KK.01.1.1.01.0009 (DATACROSS).

References

- [1] Yang, J. et al.: Aligning 2.5D Scene Fragments With Distinctive Local Geometric Features and Voting-Based Correspondences, *IEEE Transactions on Circuits and Systems for Video Technology*, **29** (2019) 3, pp. 714-729, ISSN: 1051-8215
- [2] Blais, G. & Levine, M. D.: Registering multiview range data to create 3D computer objects, *IEEE Transactions on Pattern Analysis and Machine Intelligence*, **17** (1995) 8, pp. 820-824, ISSN: 1939-3539
- [3] Huber, D. & Hebert, M.: Fully automatic registration of multiple 3D data sets, *Image Vis. Comput.*, **21** (2003), pp. 637-650, ISSN: 0262-8856
- [4] Tombari, F. et al: Unique Signatures of Histograms for Local Surface Description, *Proceedings of 11th IEEE European Conference on Computer Vision (ECCV) 2010*, pp. 356-369, ISBN: 978-3-642-15558-1, Greece, 2010, Springer, Berlin, (2010)
- [5] Guo, Y. et al.: Rotational projection statistics for 3D local surface description and object recognition, *International journal of computer vision*, **105** (2013) 1, pp. 63-86, ISSN: 1573-1405
- [6] Johnson, A. E. & Hebert, M.: Using spin images for efficient object recognition in cluttered 3D scenes, *IEEE Transactions on Pattern Analysis and Machine Intelligence*, **21** (1999) 5, pp. 433-449, ISSN: 1939-3539
- [7] Li, Y. et al.: Database-Assisted Object Retrieval for Real-Time 3D Reconstruction, *Comput. Graph. Forum*, **34** (2015) 2, pp. 435-446, ISSN: 0167-7055
- [8] Magnusson, M. et al.: Scan Registration for Autonomous Mining Vehicles Using 3D-NDT, *Journal of Field Robotics*, **24** (2007) 10, pp. 803-827, ISSN: 1556-4959
- [9] Whelan, T. et al.: Real-time large-scale dense RGB-D SLAM with volumetric fusion, *Int. J. Rob. Res.*, **34** (2014) 4-5, pp. 598-626, ISSN: 0278-3649
- [10] Zhao, W. et al.: Alignment of continuous video onto 3D point clouds, *IEEE Transactions on Pattern Analysis and Machine Intelligence*, **27** (2004) 8, pp. 1305-1318, ISSN: 1939-3539
- [11] Tsai, C.-Y. & Huang, C.-H.: Indoor Scene Point Cloud Registration Algorithm Based on RGB-D Camera Calibration, *Sensors*, **17** (2017) 8, 19 pages, ISSN: 1424-8220
- [12] Dai, H. et al.: Non-rigid 3D Shape Registration Using an Adaptive Template, *Proceedings of 18th IEEE European Conference on Computer Vision (ECCV) 2018*, vol. 11132, pp. 48-63, ISBN: 978-3-030-11018-5, Germany, 2018, Springer, Berlin, (2018)
- [13] Diez, Y. et al: A Qualitative Review on 3D Coarse Registration Methods, *ACM Computing Surveys*, **47** (2015) 3, pp. 45, ISSN: 1557-7341
- [14] Tombari, F. et al: Performance Evaluation of 3D Keypoint Detectors, *Int. J Comput. Vis.*, **102** (2013), pp. 198-220, ISSN: 1550-6185

- [15] Dutagaci, H. et al.: Evaluation of 3D interest point detection techniques via human-generated ground truth, *Vis. Comput.*, **28** (2012) 9, pp. 901-917, ISSN: 1432-2315
- [16] Tonioni, A. et al.: Learning to Detect Good 3D Keypoints, *Int. J. Comput. Vis.*, **126** (2018), pp. 1-20, ISSN: 1573-1405
- [17] Lin, X. et al.: 3D Keypoint Detection Based on Deep Neural Network with Sparse Autoencoder, Available from <https://arxiv.org/abs/1605.00129>.
- [18] Zhong, Y.: Intrinsic shape signatures: A shape descriptor for 3D object recognition, *Proceedings of 12th International Conference on Computer Vision Workshops*, pp. 689-696, ISBN: 978-1-4244-4442-7, Japan, (2009)
- [19] Zaharescu, A. et al.: Surface feature detection and description with applications to mesh matching, *Proceedings of Conference on Computer Vision and Pattern Recognition*, pp. 373-380, ISBN: 1063-6919, USA, (2009), IEEE, Miami, (2009)
- [20] Sipiran, I. & Bustos, B.: Harris 3d: A robust extension of the harris operator for interest point detection on 3D meshes, *The Visual Computer*, **27** (2011) 11, pp. 963-976, ISSN: 1432-2315
- [21] Sun, J. et al.: A concise and provably informative multi-scale signature based on heat diffusion, *Proceedings of SGP09: Eurographics Symposium on Geometry Processing*, **28** (2009) 5, pp. 1383-1392, ISBN: 1467-8659, Germany, (2009)
- [22] Rusu, R. B. et al.: Fast Point Feature Histograms (FPFH) for 3D registration, *Proceedings of 2009 IEEE International Conference on Robotics and Automation*, pp. 3212-3217, ISBN: 1050-4729, Japan, (2009)
- [23] Suwajanakorn S. et al.: Discovery of latent 3D keypoints via end-to-end geometric reasoning, *Proceedings of the 32nd International Conference on Neural Information Processing Systems (NIPS'18)*, Bengio, S. et al (Eds), pp. 2063-2074, Curran Associates Inc., NY, (2018)
- [24] Guo, Y. et al.: A comprehensive performance evaluation of 3D local feature descriptors, *International Journal of Computer Vision*, **116** (2015) 1, pp. 66-89, ISSN: 1573-1405
- [25] Quan, S. et al.: Local voxelized structure for 3D binary feature representation and robust registration of pointclouds from low-cost sensors, *Information Sciences*, **444** (2018) May 2018, pp. 153-171, ISSN: 0020-0255
- [26] Rusu, R.B.: Aligning point cloud views using persistent feature histograms, *Proceedings of 2008 IEEE/RSJ International Conference on Intelligent Robots and Systems*, pp. 3384-3391, ISBN: 2153-0866, France, (2008)
- [27] Charles, R. Q. et al.: PointNet: Deep Learning on Point Sets for 3D Classification and Segmentation, *Proceedings of 2017 IEEE Conference on Computer Vision and Pattern Recognition (CVPR)*, pp. 77-85, ISBN: 1063-6919, Hawaii, (2017)
- [28] Zeng, A. et al.: 3DMatch: Learning Local Geometric Descriptors from RGB-D Reconstructions, *Proceedings of 2017 IEEE Conference on Computer Vision and Pattern Recognition (CVPR)*, pp. 199-208, ISBN: 1063-6919, Hawaii, (2017)
- [29] Khoury, M. et al: Learning compact geometric features, *Proceedings of IEEE International Conference on Computer Vision (ICCV)*, pp. 153-161, ISSN: 2380-7504, Venice, (2017)
- [30] Deng, H. et al.: PPFNet: Global Context Aware Local Features for Robust 3D Point Matching, *Proceedings of 2018 IEEE Conference on Computer Vision and Pattern Recognition (CVPR 2018)*, ISBN: 1063-6919, (2018)
- [31] Deng, H. et al.: PPF-Foldnet: Unsupervised Learning of Rotation Invariant 3D Local Descriptors, *Proceedings of European Conference on Computer Vision (ECCV 2018)*, pp. 620-638, ISBN: 978-3-030-01228-1, Munich, (2018)
- [32] Yew, Z.J. & Lee, G.H.: 3DFeat-Net: Weakly Supervised Local 3D Features for Point Cloud Registration, *Proceedings of European Conference on Computer Vision (ECCV 2018)*, pp. 630-646, ISBN: 978-3-030-01267-0, Munich, (2018)
- [33] Yang, J. et al.: A Performance Evaluation of Correspondence Grouping Methods for 3D Rigid Data Matching, *IEEE transactions on pattern analysis and machine intelligence*, **14** (2015) 8, 15 pages, ISSN: 1939-3539
- [34] Azimi, S. & Gandhi, T.K.: Performance comparison of 3D correspondence grouping algorithm for 3D plant point clouds, Available from <https://arxiv.org/abs/1909.00866>
- [35] Chen, H. & Bhanu B.: 3D free-form object recognition in range images using local surface patches, *Proceedings of the 17th International Conference on Pattern Recognition 2004*, vol. 3, pp. 136-139, ISBN: 1051-4651, Cambridge, (2004)
- [36] Tombari, F. & Di Stefano, L.: Object Recognition in 3D Scenes with Occlusions and Clutter by Hough Voting, *Proceedings of Fourth Pacific-Rim Symposium on Image and Video Technology*, pp. 349-355, ISBN: 978-1-4244-8890-2, Singapore, (2010)
- [37] Rodolà, E. et al.: A Scale Independent Selection Process for 3D Object Recognition in Cluttered Scenes, *Int. J. Comput. Vis.*, **102** (2013) 1-3, pp. 129-145, ISSN: 1573-1405

- [38] Attia, M. et al.: On Performance Evaluation of Registration Algorithms for 3D Point Clouds, *Proceedings of 13th International Conference on Computer Graphics, Imaging and Visualization (CGiV)*, pp. 45-50, ISBN: 978-1-5090-0811-7, Beni Mellal, (2016)
- [39] Aiger, D. et al.: 4-points Congruent Sets for Robust Pairwise Surface Registration, *ACM Transactions on Graphics Article*, **27** (2008) 3, ISSN: 1557-7368
- [40] Mohamad, M. et al.: Generalized 4-Points Congruent Sets for 3D Registration, *Proceedings of 2nd International Conference on 3D Vision*, pp. 83-90, ISBN: 978-1-4799-7000-1, Tokyo, (2014)
- [41] Mellado, N. et al.: Super 4PCS fast global pointcloud registration via smart indexing, *Computer Graphics Forum*, **33** (2014) 5, pp. 205-215, ISSN: 1467-8659
- [42] Mohamad, M. et al.: Super Generalized 4PCS for 3D Registration, *Proceedings of 2015 International Conference on 3D Vision*, pp. 598-606, ISBN: 978-1-4673-8332-5, Lyon, (2015)
- [43] Aoki, Y. et al.: PointNetLK: Robust & Efficient Point Cloud Registration Using PointNet, *Proceedings of 2019 Conference on Computer Vision and Pattern Recognition (CVPR 2019)*, pp. 7156-7165, ISBN: 2575-7075, Long Beach, (2019)
- [44] Lucas, B.D. & Kanade, T.: An iterative image registration technique with an application to stereo vision, *Proceedings of the 7th international joint conference on Artificial intelligence*, vol. 2, pp. 674-679, Vancouver, (1981) Available from https://cecas.clemson.edu/~stb/kl/lucas_bruce_d_1981_1.pdf
- [45] Lu, W.: DeepICP: An end-to-end deep neural network for 3D point cloud registration, 2019, Available from <https://arxiv.org/abs/1905.04153>
- [46] Qi, C. R. et al.: PointNet++: deep hierarchical feature learning on point sets in a metric space, *Proceedings of the 31st International Conference on Neural Information Processing Systems (NIPS'17)*, pp. 5105-5114, ISBN: 978-3-319-94042-7, Long Beach, (2017)
- [47] Wang, Y. & Solomon, J.: Deep closest point: Learning representations for point cloud registration, 2019, Available from <https://arxiv.org/abs/1905.03304>
- [48] Wang, Y. et al.: Dynamic Graph CNN for Learning on Point Clouds, *ACM Trans. Graph.*, **1** (2019) 1, 13 pages, ISSN: 1557-7368
- [49] Li, J. & Zhang, C.: Iterative Matching Point, Available from <http://export.arxiv.org/pdf/1910.10328>
- [50] Wang, J. & Solomon, J.: Prnet: Self-supervised learning for partial-to-partial registration, *Proceedings of 33rd Conference on Neural Information Processing Systems*, pp. 8814-8826, Vancouver, (2019)
- [51] Jang, E. et al.: Categorical Reparameterization with Gumbel-Softmax, Available from <https://arxiv.org/abs/1611.01144>
- [52] Sarode, V. C. et al.: Pcnnet: Point cloud registration network using PointNet encoding, 2019, Available from <https://arxiv.org/abs/1908.07906>
- [53] Besl, P. & McKay, H.: A method for registration of 3-d shapes, *Proceedings of IEEE Transactions on Pattern Analysis and Machine Intelligence*, **14** (1992) 2, pp. 239-256, ISSN: 1939-3539
- [54] Rusinkiewicz, S. & Levoy, M.: Efficient variants of the icp algorithm, *Proceedings Third International Conference on 3-D Digital Imaging and Modeling*, pp. 145-152, ISBN: 0-7695-0984-3, Quebec City, (2001)
- [55] Gelfand, N. et al.: Geometrically stable sampling for the icp algorithm, *Proceedings of Fourth International Conference on 3-D Digital Imaging and Modeling*, pp. 260-267, ISBN: 0-7695-1991-1, Banff, (2003)
- [56] Neugebauer, P. J.: Geometrical cloning 3D objects via simultaneous registration of multiview range images, *Digitally Archiving Cultural Objects*, pp. 71-88, 978-0-387-75807-7
- [57] Park, S. & Subbarao, M.: A fast point-to-tangent plane technique for multi-view registration in *Proceedings of Fourth International Conference on 3-D Digital Imaging and Modeling*, pp. 276-283, ISBN: 0-7695-1991-1, Banff, (2003)
- [58] Yang, J. et al.: Go-ICP: A Globally Optimal Solution to 3D ICP Point-Set Registration, *IEEE Transactions on Pattern Analysis and Machine Intelligence*, **38** (2016) 11, pp. 2241-2254, ISSN: 0162-8828
- [59] Fischler, M. A. & Bolles, R. C.: Random sample consensus: A paradigm for model fitting with applications to image analysis and automated cartography, *Commun. ACM*, **24** (1981) 6, pp. 381-395, ISSN: 0001-0782
- [60] Fontanelli, D. et al.: A fast ransac-based registration algorithm for accurate localization in unknown environments using lidar measurements, *Proceedings of 2007 IEEE International Conference on Automation Science and Engineering*, pp. 597-602, ISBN: 2161-8089, Scottsdale, (2007)
- [61] Pankaj, D. S. & Nidamanuri, R. R.: A robust estimation technique for 3d point cloud registration, *Image Analysis Stereology*, **35** (2016) 1, pp.15-28, ISSN: 1580-3139
- [62] Chen, C.S. et al.: Ransac-based darces: a new approach to fast automatic registration of partially overlapping range images, *IEEE Transactions on Pattern Analysis and Machine Intelligence*, **21** (1999) 11, pp. 1229-1234, ISSN: 1939-3539
- [63] Biber, P. & Strasser, W.: The normal distributions transform: A new approach to laser scan matching, *Proceedings 2003 IEEE/RSJ International Conference on Intelligent Robots and Systems*, pp. 2743-2748, ISBN: 0-7803-7860-1, Las Vegas, (2003)

- [64] Magnusson, M. & Duckett T.: A comparison of 3D registration algorithms for autonomous underground mining vehicles, *Proceedings of the European Conference on Mobile Robots (ECMR) 2005*, pp. 86-91, Ancona, (2005)
- [65] Stoyanov, T. et al.: Fast and accurate scan registration through minimization of the distance between compact 3D ndt representations, *The International Journal of Robotics Research*, **31** (2012) 12, pp. 1377-1393, ISSN: 0278-3649

Authors:

Mag. Math. David Bojanić (corresponding author)
Mag. Ing Kristijan Bartol; Assist. Prof. Tomislav Petković, PhD.; Prof. Tomislav Pribanić, PhD.
University of Zagreb Faculty of Electrical Engineering and Computing
Unska ul. 3, 10 000 Zagreb, Croatia
Phone: +(385) (1) 3712 543

E-mail: David.Bojanic@fer.hr
E-mail: tomlslav.petkovic.ml@fer.hr

DEVELOPMENT OF A FEMALE BODY TYPES CLASSIFICATION METHOD

Maja MAHNIĆ NAGLIĆ & Slavenka PETRAK

Abstract: *The paper presents research on female body anthropometric characteristics, with the purpose of grouping and classifying different body shapes types. Classification is based on the numerical ratio of variables that describe the shape of lateral body curve in longitudinal frontal plane section. The existing methods for classifying the woman's body shape are mainly based on the ratio of the three basic circumference measures, whereby the overall circumference measures do not give a clear picture of the observed body cross section shape, and thus the shape cannot be clearly described. Experimental part of the paper includes defining the variables, i.e. shape indicators that are describing lateral body curve for shape classification and are calculated from a set of body measures determined using a 3D body scanner, which ensures the reliability and objectivity of the method. The study was conducted on a female population sample, whereby statistical data processing showed identification of the three female body shape groups, that significantly differ in defined shape indicators. Based on the analysis of the particular indicators influence on a belonging to a certain body type, a method for the classification of female body shapes was developed.*

Keywords: *female body types, 3D body scanner, lateral body curve, classification method*

1. Introduction

The modern era in fashion and clothing is characterized by the aspiration of people to emphasize their own personality through building their own dressing style, which within the changing fashion trends and the selection of garments contribute in the best possible way to the visual correction of body shape. The appropriateness of the clothing design and construction, customized for different female body shapes is the subject of numerous discussions between designers, fashion stylists and researchers who are engaged in this issue [1,2]. Fashion trends often offer the clothing styles that are not equally acceptable for different age groups, body sizes and shapes. Proper selection of clothing can positively contribute to visual body shaping and attractiveness of the person's appearance, thus stimulating a sense of comfort and self-confidence. Accordingly, there are certain preferences of a particular body type towards purchasing different types of clothing [3]. Sizing systems used for clothing production are constantly being developed and improved [4], giving a quantitative characterization of the human body morphological characteristics based on average anthropometric measurements of a particular sex and targeted age group. However, in terms of information on the particular clothing size, it still lacks a clear interpretation and visualization of morphology, or body shape for a certain clothing size, which is highly important in the design and construction of clothing models that intend to contribute to the visual correction of different body figures. In that sense, recognition and accurate identification of the body shape is the basis for an appropriate choice of clothing.

In the field of scientific research, female body types, typical for women of different figures and statures are differently defined by different authors [4-6]. The most commonly used methods for body shape evaluation are analysis of body measures and circumferences proportions [5,6]. Simmons categorized body shapes in nine types: hourglass, hourglass with pronounced lower body, hourglass with pronounced upper body, spoon, rectangle, diamond, oval, triangle and reversed triangle. Developed software „Female Figure Identification Technique (FFIT) for Apparel“ uses scanned body models and identifies different body types based on ratios of bust, waist, high hips, hips, belly and abdomen circumferences [5]. Petrova and Ashdown categorized shapes of lower body into three groups: flat, middle and curved type. Categorization was conducted based on ratios of waist and hip circumferences and used for determination of ease allowances for construction of pants according to the particular type [7].

The main insufficiency of presented methods is that they are based only on circumference measurements, while there is no information about body widths in antero-posterior and sagittal plane, which are significant indicators of body shape, and by that, necessary for detailed analysis. New technologies like 3D body scanning, that enable computer analysis of anthropometric body characteristics have made significant contributions to the research in the field [8,9]. 3D body scanning enables precise anthropometric measurements and morphology analysis where it is possible to numerically determine variables that are significant for body shape classification. Numerical values and range intervals of the particular body shape

variables can also be used in different approaches for the customization of clothing block patterns according to different body shapes. That way, complex process of pattern alterations for a certain size and body shape can be improved and automated, making the development process of made-to-measure clothing easier and faster [10-12]. In that sense, the research presented in the paper was conducted with the purpose of numerical analysis of female body shapes and the development of a method for automatic body shape classification based on the measurements describing lateral body curve on scanned 3D body models.

2. Experimental part

2.1 3D body scanning of a female test sample

3D body scanning was performed according to standard ISO 20685:2010, on a sample of 126 adult females aged 20 to 40 years in an upright standing position. The structure of a test sample based on the basic body measurements and distribution of measurement values are presented in Table 1. Based on the analysis of the basic body measurements distribution, it can be expected that the main body type in the sample will correspond to an hourglass type and the differences between types will be determined based on the characteristics of the upper and lower torso. A customized measurement menu with basic body measurements and selection of 12 body dimensions for calculation of shape indicators was created within the automatic measurement protocol (Table 2). The assumption is that the lateral body curves in the frontal plane can be described by the relationships of the selected width measurements on the characteristic shoulders, chest, waist and hip areas in the frontal plane and their corresponding heights, measured from the ground in a standing position, thus classifying the body shape.

Table 1: Distribution of basic body measurements values in studied test sample

	Breast girth (<i>BG</i>)	Waist girth (<i>WG</i>)	Hips girth (<i>HG</i>)
Mean [cm]	92.9	72.3	98.2
SD	8.6	8.4	7.5
CV%	9.2	11.6	7.6
Min [cm]	78.1	59.1	84.5
5 th [cm]	80.3	62.0	89.5
10 th [cm]	83.7	63.4	90.7
25 th [cm]	87.3	65.9	92.3
50 th [cm]	91.6	70.7	96.7
75 th [cm]	97.1	76.0	102.0
90 th [cm]	102.4	83.1	108.1
95 th [cm]	109.1	87.1	113.5
Max [cm]	126.4	106.3	123.1
N	126		

2.2 Definition of body shape indicators

Five angles (Q1 to Q5), approximating lateral body curve in frontal plane were defined as body shape indicators (Table 2). Q1 represents the lateral body angle between shoulders and bust circumference line, Q2 represents the lateral body angle between bust and waist circumference lines, Q3 represents the lateral body angle between waist circumference line and waistband, Q4 represents the lateral body angle between waistband and hips circumference line and Q5 represents the lateral body angle between hips and maximum hip circumference lines. Defined angles enabled numerical description of lateral body curves, reducing the number of necessary variables at the same time. All body angles are calculated analog to presented expression for calculation of Q1 indicator:

$$Q1 = \tan^{-1} \frac{(ShW - BW) / 2}{ShH - BH} [^\circ] \quad (1)$$

Table 2: Body measurements and calculation of body shape indicators

No.	Measure	Description
1.	ShW	Shoulders width
2.	ShH	Shoulders height
3.	BW	Breast width
4.	BH	Breast height
5.	WW	Waist width
6.	WH	Waist height
7.	W_2W	Waistband width
8.	W_2H	Waistband height
9.	HW	Hips width
10.	HH	Hips height
11.	H_2W	Maximum hips width
12.	H_2H	Maximum hips height

2.3 Statistical data analysis and definition of female body shapes

Obtained data on body measurements and calculated shape indicators were statistically processed using factor and k-means cluster analysis, in order to test the structure of defined indicators and to determine the number of maximally different groups present in the observed test sample. Based on the analysis of variance between and within different number of groups, three body shape types showing the greatest statistically significant differentiation between types were defined.

Table 3: K-means cluster sampling into three groups and discriminant analysis of shape indicators

Three body shape types	DF1	DF2	Plot of three defined body shape types centroids in two discriminant functions coordinates system
Eigenvalue	1.863	0.796	
R_c	0.807	0.666	
Wilks' L.	0.194	0.557	
χ^2	198.14	70.86	
Cum. Prop.	0.701	1.000	
Q1	0.472	0.320	
Q2	-0.177	0.419	
Q3	-0.498	0.738	
Q4	0.658	0.065	
Q5	0.384	0.412	
F1	2.531	0.502	
F2	-1.186	1.005	
F3	-0,291	-0.920	

Discriminant analysis was used to describe which indicators discriminate the best between the obtained types. The influence of the particular indicator on the belonging to a certain body type was analyzed based on the correlation between discriminant functions and shape indicators (Table 3). Based on the obtained results, body characteristics and indicators range values for all three body types were defined (Table 4, Figure 1).

Table 4: Descriptive statistics and distribution parameters values of body shape indicators for three different body types

		mean	SD	CV [%]	min	10	25	50	75	90	max
Body shape F1	Q1	85.86	2.80	3.26	82.45	83.10	83.88	84.72	88.14	89.13	92.56
	Q2	83.23	2.23	2.68	78.19	80.29	82.00	83.02	84.97	85.46	87.26
	Q3	68.21	3.60	5.28	60.92	62.44	66.48	68.24	69.95	71.48	76.68
	Q4	84.13	2.40	2.85	80.39	81.30	82.76	83.69	85.20	86.85	90.90
	Q5	85.11	2.33	2.74	81.15	82.03	83.66	84.54	86.36	88.21	89.46
	N	26 (20,63%)									
Body shape F2	Q1	81.84	2.25	2.75	77.45	78.72	80.37	81.65	83.73	84.71	86.86
	Q2	84.56	2.16	2.55	80.20	81.68	82.38	84.75	86.42	87.06	88.78
	Q3	73.02	1.98	2.71	69.86	70.13	71.48	72.85	74.09	75.31	79.00
	Q4	79.22	1.84	2.32	74.81	76.37	77.97	79.41	80.46	80.86	84.35
	Q5	82.69	2.77	3.35	76.70	78.87	80.07	83.33	84.58	85.52	87.68
	N	41 (32,54%)									
Body shape F3	Q1	81.54	2.32	2.85	75.02	77.39	79.95	82.08	83.21	84.49	85.31
	Q2	82.73	2.04	2.47	76.72	79.77	81.50	82.83	84.13	84.77	86.82
	Q3	68.36	2.33	3.41	57.55	65.62	67.22	68.86	69.86	70.29	71.80
	Q4	79.47	2.30	2.89	74.77	76.58	77.73	79.64	80.85	82.38	84.42
	Q5	81.32	2.36	2.90	73.78	77.61	80.13	81.37	82.87	83.92	85.81
	N	59 (46,83%)									

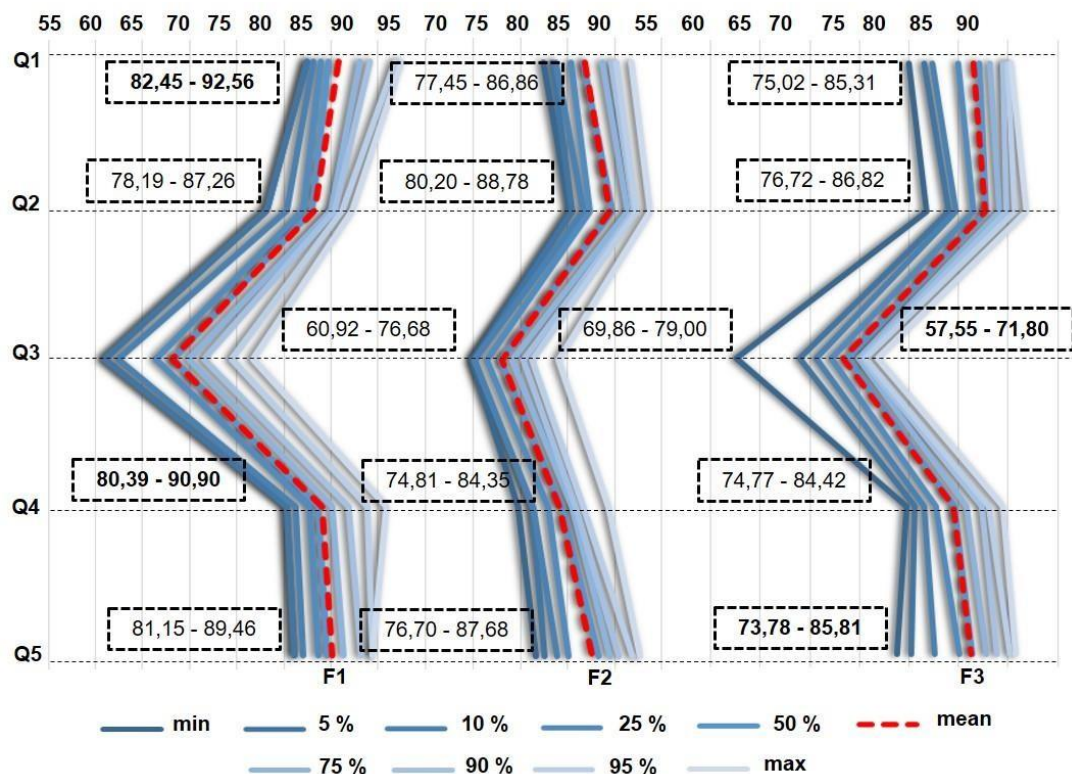

Figure 1: Plot of shape indicators range values for three defined body shape types

3. Results

Body shapes analysis results showed that defined shape indicators differ three different body shape types. In the studied population sample, 20,36 percent of test subjects belongs to body type F1, type F2 is present with 32,54 percent and type F3 with 46,83 percent (Table 4). Scanned body models of test subjects selected as representatives of three defined body shape types are shown in Figure 2. Discriminant analysis showed two significant discriminant functions (Table 3). First discriminant function, responsible for 70,1% of differences

between body shape types, correlates with indicators Q4 and Q1. Indicators Q4 and Q1 are significantly differing body shape type F1, meaning that type F1 has the most prominent characteristics. As visible on scanned model representatives, body shape F1, according to literature corresponds to square body type with less pronounced waistline and almost the same width on bust and hip areas. Because of high values of Q4 and Q1 indicators (Figure 1), lateral body curve has a characteristic straight zone between shoulders and breast line and between waistband and hip line (Figure 2).

Second discriminant function, responsible for differing body shape types F2 and F3 correlate the most with indicators Q3 and Q5, meaning that the differences between those two types are on the lower torso area. Both F2 and F3 body shape types have greater lateral body curvature and they correspond to hourglass body type. Lower values of Q3 and Q5 indicators (Figure 1) are characteristic for type F3, describing more pronounced and rounded curvature on hips area, unlike triangular straight hips slope on type F2 with higher values of Q3 and Q5 indicators (Figure 2).

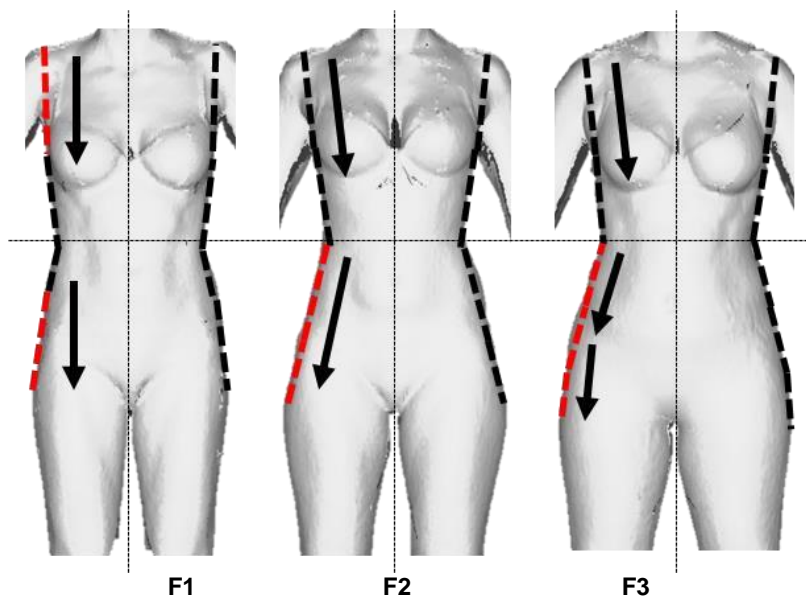

Figure 2: 3D scanned body models - representatives of three defined body shape types

According to the results of statistical data processing, a body shape classification matrix, with ranges of indicators values that determine belonging to a particular type and the order of indicators significance in the classification of body shapes was created. The total percentage of 96.85% correctly classified body shapes in the studied female test sample indicates a high possibility of body shape prediction based on the defined shape indicators (Table 5).

Table 5: Classification matrix for prediction of female body shape

Body shape type	Correctly classified test subjects [%]	Correctly classified test subjects [N]		
		F1	F2	F3
		p = 0.465	p = 0.323	p = 0.213
F1	92.593	25	0	2
F2	95.122	0	39	2
F3	100.000	0	0	59
Total	96.850	25	39	63

4. Conclusion

By presented classification of the female test sample, variables that are significant for a belonging to a particular body type were determined. Variables defined as characteristic body angles in the antero-posterior plane enable numerical description of a lateral body curve and curve segments slopes, which can be of a great importance in the process of design and construction of clothing for different body types. Thus, the body shape

can be very precisely and numerically described, unlike the existing methods that provide partially structured body shape information by comparing the main body circumferences proportions with a basic geometric shapes. Furthermore, application of 3D body scanning technology and calculation of shape indicators based on measurements defined according to ISO 7520:1998 ensures the precision, reliability and objectivity of the classification method, as well as application of the results in various fields. Information on body shape characteristics and range values of indicators responsible for belonging to a particular type can be used in the design and development process of clothing with high demands on functionality and fit. In this sense, clothing sizing systems can be further enhanced by different classifications according to body shapes, which would also enable the development of special grading methods according to the anthropometric characteristics of a particular type. Furthermore, knowledge on numerical approximations of body curves and their segments can be a starting point for the automated made-to-measure clothing construction development, where specific block pattern segments can be directly mapped from the corresponding body part of a scanned model.

References

- [1] Tama, D. & Ondogan, Z.: Fitting Evaluation of Pattern Making System According to Female Body Shapes, *Fibres and Textiles in Eastern Europe*, **22** (2014) 4, pp. 107-111, ISSN 1230-3666.
- [2] Petrak, S. et al.: Garment Collection Designed According to Female Body Types and Mass Customization Concept. *Proceedings of 8th International Textile Clothing & Design Conference - Magic World of Textiles*, Dragcevic, Z. (Ed.), pp. 406-411, ISSN 1847-7275, Dubrovnik Croatia, October 2016, University of Zagreb Faculty of Textile Technology, Zagreb (2016).
- [3] Park, J. et al.: Apparel consumers' body type and their shopping characteristics, *Journal of Fashion Marketing and Management*, **13** (2009), pp. 372-393, ISSN 1361-2026.
- [4] Fisher, T. et al.: Automatic morphological classification with Case-Based Reasoning, *Proceedings of International Conference on 3D Body Scanning Technologies*, D'Apuzzo, N. (Ed.), pp. 148-158, ISBN 978-3-033-05981-8, Lugano Switzerland, November - December 2016, Hometrica Consulting, Ascona (2016)
- [5] Simmons, K. et al.: Female figure identification technique (FFIT) for apparel Part I: Describing female shapes, *Journal of Textile and Apparel, Technology and Management* **4** (2004), pp. 1-16, Available from https://www.researchgate.net/publication/286985579_Female_Figure_Identification_Technique_FFIT_for_apparel_part_I_Describing_female_shapes
- [6] Vuruskan, A. & Bulgun, E.: Identification of female body shapes based on numerical evaluations, *International Journal of Clothing Science and Technology*, **23** (2011) 1, pp. 46-60, ISSN 0955-6222.
- [7] Petrova, A. & Ashdown, S.P.: Three-dimensional body scan data analysis: Body shape and size dependence of ease values for pants fit, *Clothing and Textiles Research Journal*, **26** (2008) 3, pp. 227-252, ISSN 0887-302X.
- [8] Hong, Y. et al.: Design and evaluation of personalized garment block design method for atypical morphology using the knowledge-supported virtual simulation method, *Textile Research Journal*, **88** (2018) 15, pp. 1721-1734, ISSN 0040-5175.
- [9] Mahnic Naglic, M. & Petrak, S.: A method for body posture classification of three-dimensional body models in the sagittal plane, *Textile Research Journal*, **89** (2019) 2, pp. 133-149, ISSN 0040-5175.
- [10] Song, H.K. & Ashdown, S.P.: Development of Automated Custom-Made Pants Driven by Body Shape, *Clothing and Textiles Research Journal*, **30** (2012) 4, pp. 315-329, ISSN 0887-302X.
- [11] Petrak, S. et al.: Impact of Male Body Posture and Shape on Design and Garment Fit, *Fibres and Textiles in Eastern Europe*, **23** (2015) 6, pp. 150-158, ISSN 1230-3666.
- [12] Su, J. et al.: Development of individualized pattern prototype based on classification of body features, *International Journal of Clothing Science and Technology*, **27** (2015) 6, pp. 895-907, ISSN 0955-6222.

Authors:

Maja MAHNIĆ NAGLIĆ, mag. ing. techn. text. (corresponding author)
University of Zagreb Faculty of Textile Technology
Prilaz baruna Filipovića 28a, 10 000 Zagreb, Croatia
Phone: +(385) (1) 3712 543

E-mail: maja.mahnic@tff.hr

Prof. Slavenka PETRAK, PhD.
University of Zagreb Faculty of Textile Technology
Prilaz baruna Filipovića 28a, 10 000 Zagreb, Croatia
Phone: +(385) (1) 3712 543

E-mail: slavenka.petrak@tff.unizg.hr

DESIGN OF FUNCTIONAL GARMENT ITEM FOR PEOPLE WITH DISABILITIES

Marija NAKIĆ & Slavica BOGOVIĆ

Abstract: *The sitting position is very common in daily life. Therefore, all clothing applied for this position should be comfortable. This is particularly important for disabled people who are restricted to the sitting position for their entire life due to their disabilities. These are people who suffer from paraplegia, multiple sclerosis or some injuries, and who have limited mobility using wheelchairs. This paper presents research on improving clothing design, adjusted to the special needs and demands of an individual, through the application of new technologies. In that respect, taking measurements is very important, as is the virtual simulation of garment fitting as the result of cuts adapted to the sitting position.*

Also, the research refers particularly to a functional garment item which could be a base for a garment model designed for disabled people.

Keywords: *disabled people, wheelchair users, functional clothing, 3D scanning, virtual garment simulation*

1. Introduction

Previous researches conducted on a garment designed for wheelchair users who want to adapt to a 'normal' life have been successfully done in certain individual segments. Given the existing offer of clothing designed for wheelchair users, users face difficulties in finding suitable clothing that provides them a good fit with style [1]. The apparel market offers the garments mostly constructed for people in the standing position, which means that their body dimensions contrast the current body dimensions in the size system. Due to sitting in a wheelchair for long hours their spine can curve or shift forward resulting in decreased trunk length. Considering the mentioned facts, it is necessary that the adapted design solutions intended for wheelchair garments include the following four dimensions: functionality, psychological aspect, interdisciplinarity and aesthetics [2]. Many wheelchair users depend on different medical devices essential for daily health maintenance. For instance, if a person uses a urinary reservoir that collects urine, it is necessary to hide it inside of clothing. Most of wheelchair users have emphasised anatomical bony bulges on the sitting body parts. The position in which they are pressured can result in severe skin irritation and cause a big problem with ulcer and bedsores [3].

The usual sitting for long hours increases moisture accumulation and leads to warming those parts, which often results in infections and bad smell. With the use of special fabrics, it is possible to find a solution through suitable designed clothing for these and similar difficulties faced by wheelchair users every day. Disabled people do not want to wear functional clothing which does not fit them or is not attractive. They want to wear modern, attractive and well adapted clothing. For that reason, this paper seeks to present a different mindset from the 'standard', which implicates the new approach to the creation of textile garments not only for wheelchair users, but for each human being who sets up their own existence in the context of fashion trends and their impact on the society [1, 2].

This paper presents the research which by a garment design is improved according to the special requirements of wheelchair user respondents by applying the new technology. Thereby, it is important to take human body measurements as well as virtual simulation of a garment fit, which is a result of the garment adjustment to the sitting position [1].

Apart from the protection, functionality and comfortability the garment has aesthetic function, by which a user expresses their own style covering some personal imperfections. People with a higher level of disability often cannot hide their flaws by the garment, so in those cases it is important to subordinate it to the disabled person's needs while doing, so it is aimed at the high level of the garment aesthetics, since the effectiveness of aesthetics has a significant influence on a human social dimension [4, 5]. Functional requirements which influence on the garment design are the limited movement of user and need for comfortable apparel, which does not cause any health problems as some irritations, bloodstream obstructions etc. Apparel for disabled persons should provide the ergonomic comfort for a sitting position focused on the human body, its physical and cognitive aspect as well as on culture and social perspective and on other aspects related to the human body dynamic [4,6].

The existing body measurement standards are adapted to the standing position, which is not acceptable for wheelchair users. Therefore, wheelchair users require a different aspect approach while being measured [7-9]. During the whole time of measurement of a person in the sitting position it is important to have a flat and horizontal seat surface, horizontal position of the upper part of the leg, vertical lower leg and the feet placed on a horizontal base Figure 1. The measured person should be dressed in underwear without shoes [9, 11].

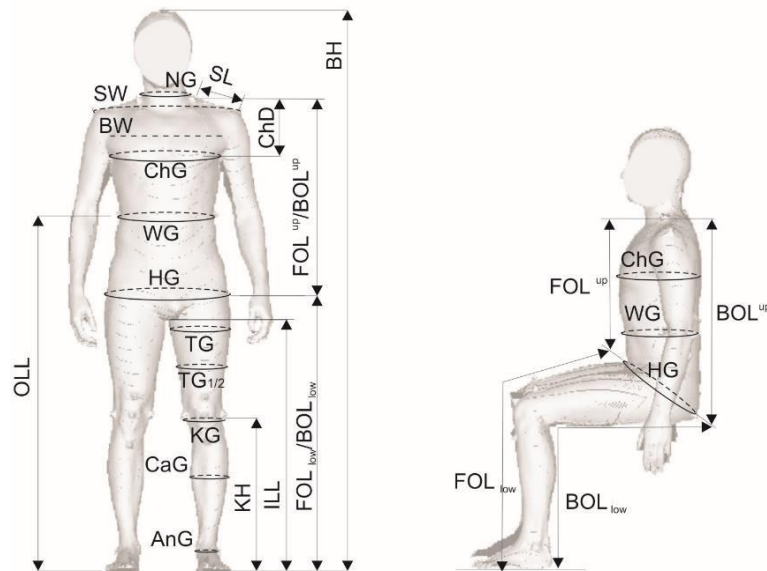

Figure 1: Definition of measurements on a 3D point cloud of the human body in the standing and sitting position [10].

2. Experimental part

This paper presents a part of results of the conducted survey on wheelchair users of different age, gender and the level of disability in the context of their quality of life. In order for clothing adapted to wheelchair users to be designed, it is required to find functional, psychological and aesthetic balance of design solution. Therefore, the survey includes different questions divided in four groups. The first group of questions refers to gender, age, social status, marital status, etc. The second group are target questions relating to their disability (e.g. disease causes, disability type, etc.), while the third group is related to clothing in general. The last group is aimed at garments for disabled people, types of fabrics, price, purchase, etc. The survey covers younger men aged between teenagers and the early 30-ies and women population aged between the early 40-ies and old age. On one hand it is noticed men like “men’s” colours and comfortable clothing in which they feel good, such as tracksuit. On the other hand, women like dark sport classic trousers. The both genders have problems while dressing and taking off cloths. Men have more problems with trousers and women with upper garments such as shirts and bras, while both genders have the same problems with putting shoes on.

On the base of the conducted survey results and digitised body outputs will be designed a garment item according to the garment design proposal. The model will be scanned by using the 3D body scanner Vitus Smart installed at the Faculty of Textile Technology of the University of Zagreb, Department of Apparel Technology. The scanning process will be made for the sitting position. Due to the specific body position the 3D point cloud often lacks points on different segments. The point cloud is reconstructed by removing outliers and closing the point cloud [12, 13]. Taking into account the natural contours of the body, the points are added and the net is completed. The Poisson reconstruction algorithm is used for the surface reconstruction of a 3D body cloud. Different methods for human body modelling have been developed, and their use has simplified the ways in which human body shapes and height are adapted. Linear regression is used for taking measurements [14–16].

The conducted measurements will be compared to the standard measurements by using a points cloud. The measurements will be related to the measures for a sitting position (waist, hips, breast, height of waist from knee position, the middle of calf, etc.) The aim of research is to design a generally acceptable model of 3D human body adaptable to the different poses and non-standard body shapes in order to enable the virtual prototyping of garments for people with limited body abilities; see Figure 2. The Figure shows the certain measurement lines of the 3D human body model needed for making of design solutions adapted to the sitting

position: back width line, breast, hips and thighs width line as well as waist height line, knee and the middle of calf height line.



Figure 2: Definition of measurements on a 3D point cloud of the human body in sitting position (a- back side, b- front and lateral side) [17, 18].

3. Results and Discussion

The aim of the research is to find a correlation between the similar shapes of human body deformations which will be able to design an individual garment item. On the base of the correlation will be defined the most appropriate computational method which by additional cut adjustment will be enabled because of the difference in the measures and all with the purpose of increasing functionality of an apparel item designed for wheelchair users. After experiment has been conducted the aim is to show that the designed apparel item has to be adjusted to the sitting position, particularly at its back part in relation to the standard model. Also, the width of hips is changed in relation to the standard so the apparel item applied for the sitting position has to be extended in relation to the standard model. The sitting model is cut on its front side in relation to the standard model due to the excess of textile material, since the apparel item applied for the sitting position has to be functional and comfortable. Of course the model length should be adjusted to the person in the sitting position so that wheelchair user could use their wheelchair without any obstacles [18, 19].

The model should be adjusted to the sitting position and its characteristics are the following:

- Simple way of getting dressed - adjusted to the limited hands' mobility;
- Allows getting dressed more easily (e.g. wrapping around the waist);
- Simple and easy button adjustment (e.g. magnetic buttoning application);
- Insured the long-lasting comfort (e.g. elastic belt);
- Allow unhampered sitting and ensure covering of underwear because of the incontinence [20].

4. Conclusion

Computational prototyping of the garment has a big potential in the contemporary clothes production. 3D body scanning has a key role in the production of garment adjusted to wheelchair users, since it enables taking the human body measures in the sitting position.

The mentioned results and 3D points obtained by the human body digitalisation will be used as an input parameter of the functional apparel item designing. For this purpose, 4D textile technology will be used by which a cut adjustment will be able. 4D textile technology is new and still not enough explored in the textile field. So far research has shown that 4D textile is made of textile with printed polymeric grid, where the grid deformation is induced by introducing residual stress in textile. The fourth dimension is related to the textile construction ability which changes its shape and function under the influence of the change in residual stress in textile.

This change is achieved by the complex interaction between hybrid materials and with the use of external stimulus. In order to shape a useful component for certain application, material characteristics, components, directions and quantity of residual stress, textile surface anisotropy, printed polymeric geometry and printed grid sample can be changed. Adjusted model of apparel item for the sitting position obtained as the result of this research should be easy to put on - adjusted to the limited movement of arms, have a simple and easily adjustable buttoning which allows smoothly comfort of sitting for long periods of time. The garment intended

for wheelchair users aims to achieve their life quality improvement in order to reach optimal conditions and possibilities for their social inclusion.

The clothing for wheelchair users must provide functionality, quick and independent dressing, psychical and psychological sense of comfort and stability, easy maintenance and should be trendy. Thus the usage of computer technologies is very important, since the design defects can be foreseen and eliminated when the garment is being developed and designed. The use of new technologies facilitates the design of functional garments for the wheelchair users [21 -23,1].

References

- [1] Nakić, M.; Bogović, S.: Computational Design of Functional Clothing for Disabled People, *Tekstilec*, **62** (2019) 1, pp. 23-33, ISSN 2350-3696
- [2] Suri, P.: Clothing Needs Assessment for Wheelchair Users, Available from http://rave.ohiolink.edu/etdc/view?acc_num=kent1470244671 Accessed: 2020-08-28
- [3] Dean, J.: Skin Health: Prevention and Treatment of Skin Breakdown, *The Siegel Rare Neuroimmune Association Journal*, 5 (2011), Available from <https://wearesna.org/resources/skin-health-prevention-and-treatment-of-skin-breakdown/> Accessed 2020-08-28
- [4] Curteza, A. et al.: Designing functional clothes for persons with locomotor disabilities. *AUTEX Research Journal*, **14** (2014) 4, pp. 281-289, ISSN 2300-0929
- [5] Hong, Y. et al.: Collaborative 3D-To-2D tight-fitting garment pattern design process for scoliotic people, *Fibres & Textiles in Eastern Europe*, **25** (2017) 5(125), pp.113-117, ISSN 1230-3666
- [6] Wang, Y. et al.: Evaluation on an ergonomic design of functional clothing for wheelchair users, *Applied Ergonomics*, **45** (2014) 3, pp. 550-555, ISSN 0003-6870
- [7] Paquet, V. & Feathers, D.: An anthropometric study of manual and powered wheelchair users, *International Journal of Industrial Ergonomics*, **33** (2004) 3, pp. 191-204, ISSN 0169-814
- [8] Talab, A. H. D. et al.: Comparison of anthropometric dimensions in healthy and disabled individuals, *Jundishapur Journal Health Sciences*, **9** (2017) 3, pp. 1-6, ISSN 2252-0627
- [9] Han, H. et al.: Comparative analysis of 3D body scan measurements and manual measurements of size Korea adult females, *International Journal of Industrial Ergonomics*, **40** (2010) 5, pp. 530-540, ISSN 0169-8141
- [10] Bogović, S. et al.: The use of new technologies in development of protective clothing: Comparative analysis of static and dynamic postures' body dimensions and application, *Autex Research Journal*, **19** (2019) 4, pp. 301-311, ISSN 2300-0929
- [11] Ujević, D. et al.: Anthropometry and the comparison of garment size systems in some European countries, *Collegium Antropologicum*, **29** (2005) 1, pp. 71-78, ISSN 1848-9486
- [12] Büttgen, B. et al.: High-speed and high-sensitive demodulation pixel for 3D imaging. In: *Proceedings of the SPIE: Three-Dimensional Image Capture and Applications VII*. Corner, B. D. et al. (Ed.), pp. 22-33, ISBN 9780819460967, San Jose, CA, USA, January 2006, SPIE, San Jose, (2006)
- [13] Liu, Y. J. et al.: A survey on CAD methods in 3D garment design, *Computers in Industry*, **61** (2010) 6, pp. 576-593, ISSN:0166-3615
- [14] Hamad, B. et al.: 3D adaptive morphotype mannequin for target population, *Journal of Ergonomics*, **8** (2018) 2, pp. 1-9, ISSN 2165-7556
- [15] Savonnet, L. et al.: A parametric model of the thigh-buttock complex for developing FE model to estimate seat pressure, *Proceedings of 5th International Digital Human Modeling Symposium*, (Ed. Wischniewski, S. et al.), pp. 2015-226, Bonn, Germany, Jun 2017, Federal Institute for Occupational Safety and Health, Dortmund (2017)
- [16] Moccozet, L. et al.: Animatable human body model reconstruction from 3D scan data using templates. *Proceedings of workshop on motion capture techniques for virtual environments*, CAPTECH'2004, pp. 73-79, Zermat, Switzerland, December (2004)
- [17] Rudolf, A. et al.: Study regarding the virtual prototyping of garments for paraplegics, *Fibers and Polymers*, **16** (2015) 5, pp.1177-1192, ISSN 1875-0052
- [18] Bogović, S. et al.: The use of new technologies in development of protective clothing: Comparative analysis of static and dynamic postures' body dimensions and application, *AUTEX Research Journal*, **19** (2019) 4, pp. 301-311, ISSN 2300-0929 and 1470-9589
- [19] Rudolf, A. et al.: Textile forms' computer simulation techniques. In *Computer simulation, (Computer and Information Science, Computer Science and Engineering)*, InTech, ISBN 978-953-51-3206-6, Rijeka, (2017), pp.67-93
- [20] Nakić, M., Bogović, S.: Functional clothing adjusted for women with disabilities, *Proceedings of Izveščkov 48. simpozij o novostih v tekstilstvu*, Gorjanc, M. and Simončič, B. (Ed.), pp. 42-42, ISBN 978-961-6900-

25-6, Ljubljana, Slovenia, June 2019, Univerza v Ljubljani, Naravoslovnotehniška fakulteta, Oddelek za tekstilstvo, grafiko in oblikovanje, Ljubljana (2019)

- [21] Move Over 3D Printing, the 4th Dimension Is Here. Available from <https://matmatch.com/blog/move-over-3d-printing-the-4th-dimension-is-here/>. Accessed 2020-02-28
- [22] 4D Textiles - morphing hybrid structures by additive manufacturing, Available from https://smarttextnetzwerk.de/images/PDF/2017-6-Workshop/RWTH_Schmelzeisen_4DTextile.pdf, Accessed 2020-02-28
- [23] Stapleton, S. E.: Finite element modeling to predict the steady-state structural behaviour of 4D textiles, *Textile Research Journal*, **89** (2018) 17, pp. 3484-3498, ISSN 0040-5175 and 1746-7748

Authors:

MSc Marija NAKIĆ (corresponding author)
University of Zagreb, Faculty of Textile Technology
Phone: +387 63 329 324

E-mail: mnakic13@gmail.com

Assoc. Prof. Slavica BOGOVIĆ, Ph.D.
University of Zagreb, Faculty of Textile Technology
Prilaz baruna Filipovića 28a, 10 000 Zagreb, Croatia
Phone+385 1 3712 543 Fax: +385 1 3712 557

E-mail: slavica.bogovic@tff.unizfg.hr



The Doctoral Students' Section (DSS)

PROFESSIONAL PAPERS

MODIFICATION OF COTTON FABRIC WITH CROSS - LINKED AND GRAFTED GELATINE

Anna BEDNAROWICZ & Zbigniew DRACZYŃSKI

Abstract: *The aim of this study was to compare effects of two types of surface modification of cotton fabric using gelatine. One of the used methods was to cross-link gelatine on the surface of the cotton product, while the other was to graft gelatine on the surface of the product. Commercially available gelatine was used, which in one case was crosslinked with glutaraldehyde, while in the other it was grafted onto the fabric by modifying its surface with citric acid. To confirm the modification, the FTIR ATR technique was used and colour tests were carried out with the use of dyes used for dyeing protein products. In addition, the sorption properties of modified fabrics were also checked.*

Keywords: *gelatine, cellulosic textiles, glutaraldehyde, citric acid, grafting, cross-linking*

1. Introduction

The most popular cellulose fibre used in the textile industry is cotton. Cotton fibres are not homogeneous in terms of their quality. The quality of the fibre is influenced by many factors, among which we can distinguish: cotton species, place of cultivation, plant growth process and technology in which the harvest is performed, and factors not closely related to the growing process, i.e. the process of preparing fibres for processing [1]. The physical and chemical properties of cellulose have an essential influence on the properties of cotton fibre. The unquestionable advantage of this type of fibre is its high hygroscopicity and wetting rate. They are also characterized by good heat resistance, smooth grip and low tendency to electrification [2]. These are fibres with good spinnability and relatively low price. Their further advantage is their dyeability. However, they are generally not ideal and have a number of drawbacks, among which we can mention creasing tendency, low chemical and biological resistance, low rubbing resistance, easy flammability, ease of staining and difficulty in the removal of the resulting dirt, as well as the fact that it easily deforms after the washing process [3, 4].

Cotton fabric may be subjected to modifications such as mercerisation or cationization [5,6]. Research was also conducted on grafting collagen on their surface in order to change their properties and give them characteristics similar to protein fibres. However, this process is complicated and requires a number of operations, which is the result of the lack of reactive groups on the surface of cotton fibres. Nevertheless, collagen may pose a potential hazard to users due to the presence of a sequence of amino acids responsible for the possibility of an immunogenic reaction by a potential user of the product. Therefore, it is possible to replace it with gelatine, which as a result of chemical treatment is deprived of this negative property, and moreover, unlike collagen, it can be easily dissolved in water without the use of additional chemicals [3]. The aim of this work is to modify textile cotton products with cross-linked and grafted gelatine in order to give them properties similar to those of protein fibres.

2. Methods and materials

Mercerization of cotton fabric was carried out for 1 min in a 20% NaOH solution at temperature of 24 °C and under tension. Cotton modification with citric acid was carried out at 24 °C for 1, 2 and 3 h. The acid concentration was 1 and 3 moles in relation to the amount of cellulose moles, the catalyst used was N, N 'Dicyclohexylcarbodiimide, and the used solvent was Dimethylformamide.

Next, 0.5% aqueous gelatine solution (gelatine from porcine skin) was applied onto samples previously modified with citric acid and those that was only mercerized. The modification was carried out for 1 hour at 24 °C. For samples not modified with citric acid, a 0.5 % and 1.5 % glutaraldehyde solution was used as the crosslinking agent. The cross-linking process lasted 10, 30 and 60 minutes at the temperature of 24 °C. Each sample was rinsed several times in distilled water until the aldehyde group C=O was removed, which was confirmed by the Tollens' test conducted with the water used for rinsing.

To test the water sorption of modified fabrics, the samples were placed in a desiccator for 24 hours in which the humidity was 100 % at 24 °C. Then they were dried to constant weight at 40 °C.

$$M = \frac{W-D}{W} \cdot 100 \% \quad (1)$$

where M is moisture content (%), W is the mass of the original sample (g), and D is mass of dried sample (g).

To confirm the modification, a dyeing process was carried out using an acid dye (Acid Brown GOI 100%) at a concentration of 1 % in relation to the weight of the fibre. The bath modulus was 1:50 and the duration of the process was 1.5 h. It was carried out at 24 °C. The measurement of the color difference (ΔE) was made using the Jasco spectrophotometer. The measurements were made in the wavelength range of 360- 830 nm. Another way of verifying both types modifications was the FTIR ATR analysis [7,8,9].

3. Results

If the cotton fabric is modified with gelatine, then cross-linked with glutaraldehyde, its reduced ability to absorb water can be noticed (Fig. 1). This is due to the use of the coating method - gelatine covers the cotton fibres which makes it impossible for them to absorb water, moreover, the cross-linking process additionally reduces their sorption capacity.

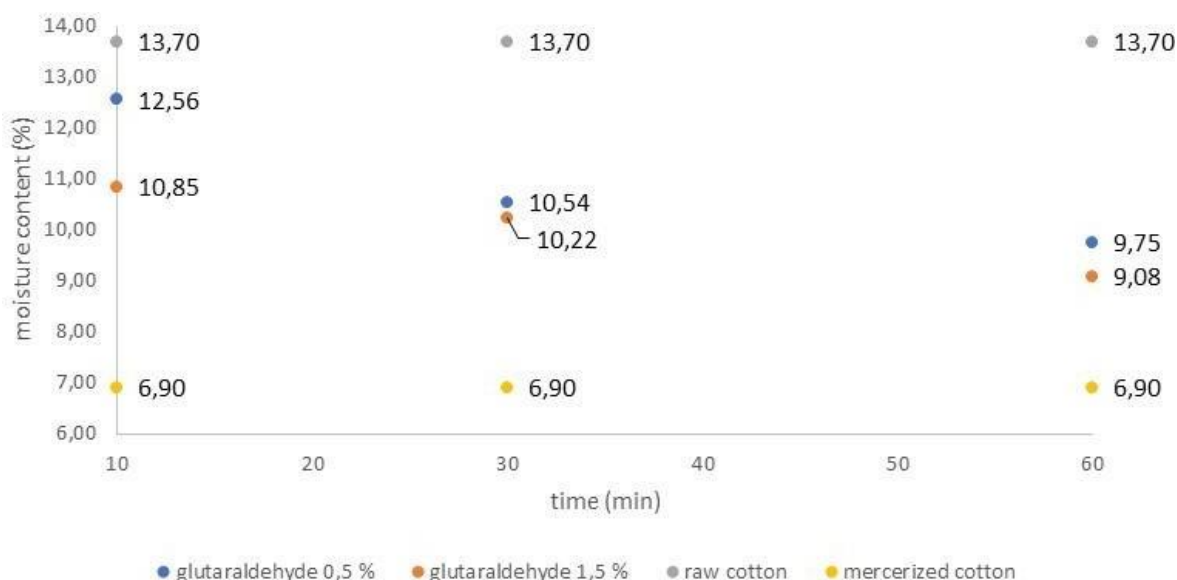

Figure 1: Moisture content of cotton samples modified with cross-linked gelatine.



Figure 2: Moisture content of cotton samples modified with grafted gelatine and citric acid.

Samples on the surface of which gelatine has been grafted using citric acid have different characteristics (Fig. 2). In case of using lower concentration of citric acid we can observe an increase in sorption properties with an increase in modification time. However, when higher citric acid concentration is used, the water absorption

capacity decreases. This is due to the higher amount of gelatine molecules on the surface, which blocks water access to the fibres.

An increase in the sorption of the acid dye of modified fabrics can be observed by determining the ΔE . The resulting colour is much more intense than for raw and mercerized cotton (Fig. 3, 4). The varying intensity of the colouring may be related to the unevenness of the modification. By averaging the results obtained for both types of modifications, it can be concluded that better dye depletion was obtained for cross-linked gelatine modifications.

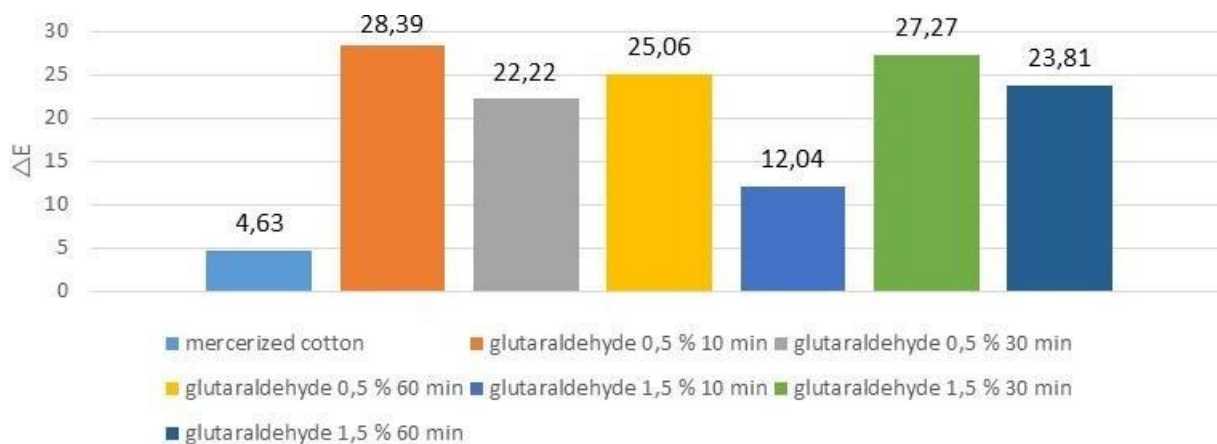

Figure 3: ΔE values for samples modified with cross-linked gelatine.

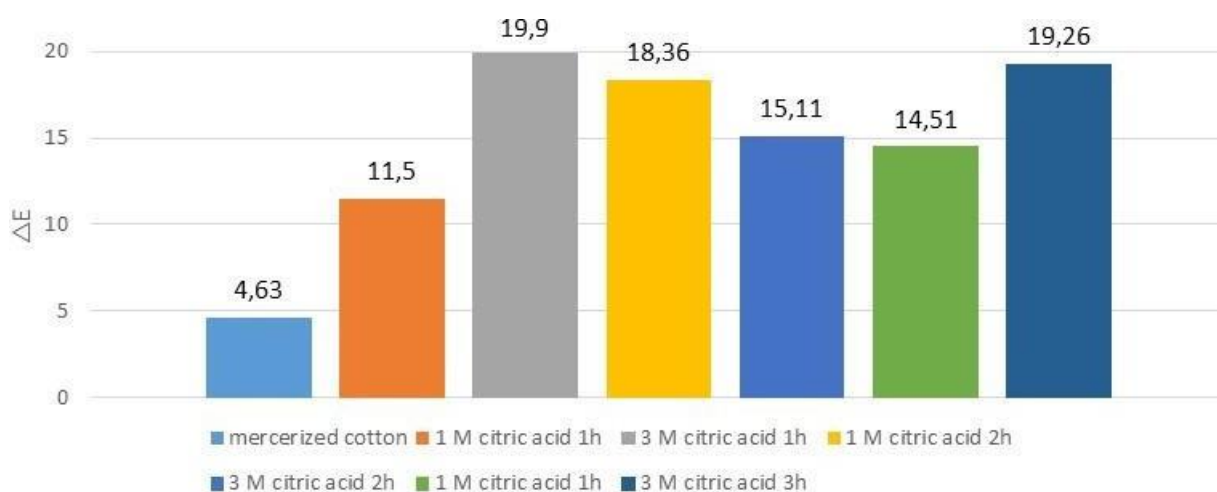

Figure 4: ΔE values for samples modified with grafted gelatine and citric acid.

The spectra (Fig. 5-8) obtained for fabrics modified with cross-linked gelatine with glutaraldehyde in different concentrations and time variants indicate the appearance of N-H groups in the wavelength range 1500-1650 cm^{-1} . We can observe that in all cases it was possible to implement gelatine on cotton fibres. In case of some spectra the peaks are much more visible but this is probably due to the unevenness of the modification as well as the fact that measurement is performed over a small area.

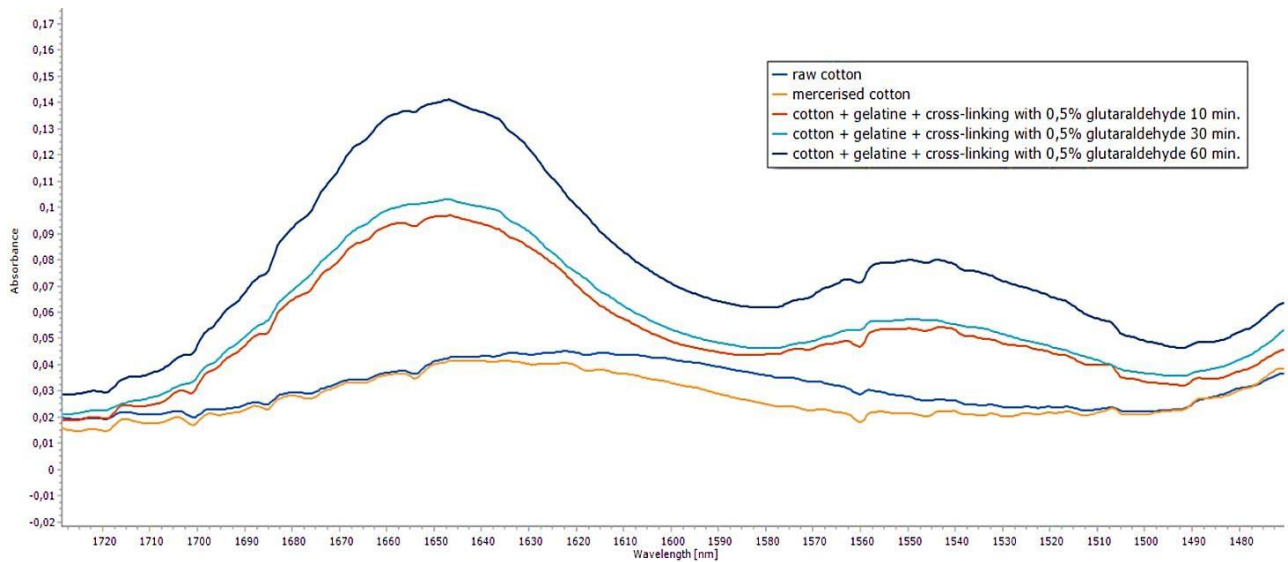

Figure 5: FTIR spectrum for cotton fabric modified with gelatine crosslinked with 0.5 % glutaraldehyde.

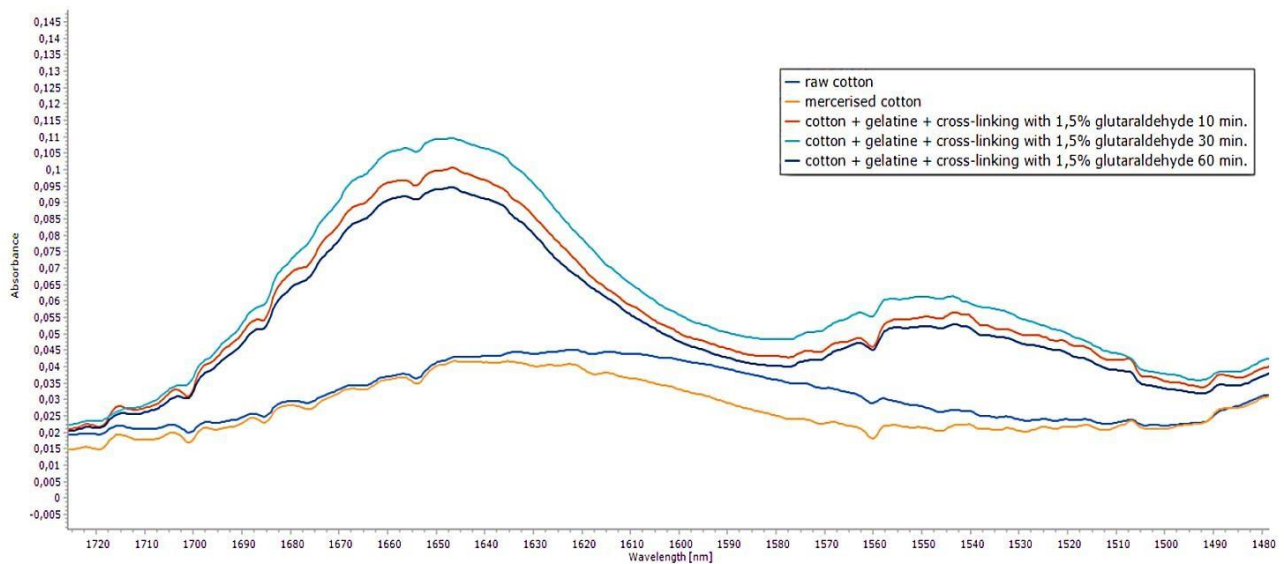

Figure 6: FTIR spectrum for cotton fabric modified with gelatine crosslinked with 1.5 % glutaraldehyde..

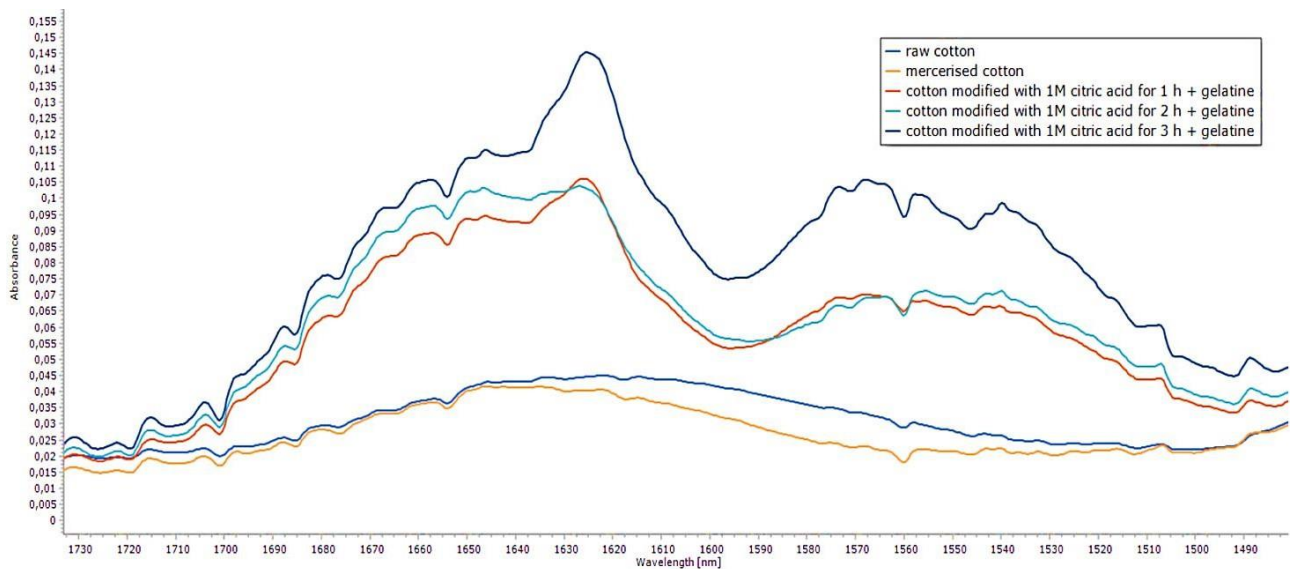

Figure 7: FTIR spectrum for cotton fabric modified with grafted gelatine and 1 M citric acid.

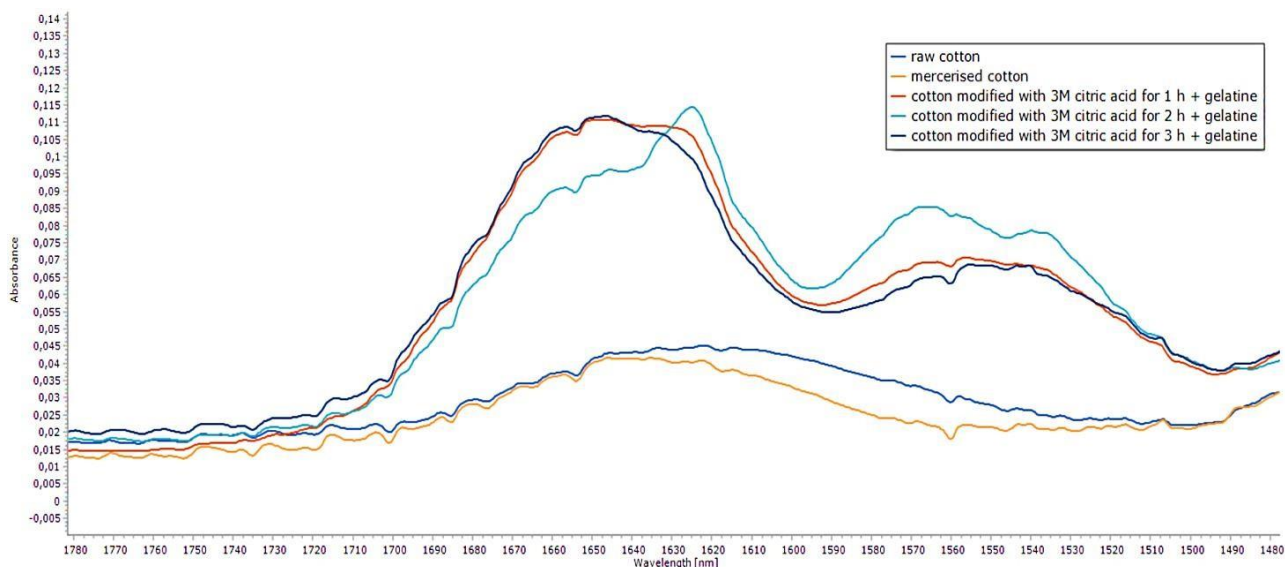

Figure 8: FTIR spectrum for cotton fabric modified with grafted gelatine and 3 M citric acid.

4. Conclusion

Gelatine grafting was carried out with the use of dicyclohexyl carbodiimide (DCC) as a catalyst, which allows the chemical bonding of gelatine to the cotton surface by creating permanent ester bonds. Modification of cotton fabric with cross-linked gelatine is easy to conduct and allows to change the characteristics of cellulose fibres. These fibres gain properties similar to those of protein fibres, which can be proved by higher dyeability and thus better sorption of the acid dye, traditionally used for colouring protein fibres. FTIR analysis confirmed the presence of -NH groups, characteristic for protein products. An unquestionable advantage of this kind of modification is the lack of possibility of occurrence of immunological reaction of a potential user of the product, which may be hygienic and cosmetic products.

The successful modification of the gelatine on the surface of cellulose products is a precursor for further modification. It will involve the formation of quaternary ammonium salts on the surface of the product, which will have bacteriostatic properties. Since the zeta potential of the produced materials is most likely to have been changed, the aim of the next modification will be to produce a material capable of adhesion of bacteria, but at the same time capable of destroying them.

References

- [1] Klemm, D., et al: Comprehensive Cellulose Chemistry Volume I Fundamentals and Analytical Methods. WILEY-VCH, 9783527294138, Weinheim, (1998)
- [2] Maher, R.R., Wardman, H.R.: The Chemistry of Textile Fibres 2nd Edition. The Royal Society of Chemistry, 1782620230, Cambridge, (2015)
- [3] Urbańczyk, G.: Nauka o włóknie, Wydawnictwo Naukowo- Techniczne, 8320410142, Warszawa, (1985)
- [4] Teulé, F.: Spinning of fibres from protein solutions, In Biologically Inspired Textiles 1st Edition, Woodhead Publishing Limited, 9781845695088, Cambridge, (2008), pp.44-66
- [5] Karmakar, R. S.: Chemical Technology in the Pre-Treatment Processes of Textile, Elsevier Science, 9780444500601, (1999)
- [6] Pruś, S., Gajdzicki, B.: „Zrównoważone” działania w uprawie i chemicznej obróbce bawełny, Proceedings of Stowarzyszenie Polskich Chemików Kolorystów, pp. 93-130, 978-83-927176-5-2, Piechowice, September 2013, Fundacja Rozwoju Polskiej Kolorystyki, Łódź, (2013)
- [7] Banaś, M., Pietrucha, K.: Typy i struktura białka kolagenowego. Zeszyty naukowe Politechniki Łódzkiej, **1058**. (2009), pp.93-104, 1509-7013
- [8] Lipp- Symonowicz, B., Sztajnowski, S. & Kulak, A.: IR Spectroscopy as a Possible Method of Analysing Fibre Structures and Their Changes Under Various Impacts, Available form <https://www.intechopen.com/books/infrared-radiation/ir-spectroscopy-as-a-possible-method-of-analysing-fibre-structures-and-their-changes-under-various-i> Accessed: 10.07.2020

- [9] Sztajnowski, S.: Metoda spektroskopii absorpcyjnej w podczerwieni w badaniach polimerowych materiałów włókienniczych. Monografie Politechniki Łódzkiej, 9788372837394, Łódź, (2016)
- [10] Ingamells, W.: Colour for Textiles: A user's handbook, Society of Dyers and Colourists, 0901956562, (1993)

Authors:

M. Sc, Eng Anna BEDNAROWICZ (corresponding author)
Prof. Dr Eng Zbigniew DRACZYŃSKI
Institute of Material Science of Textiles and Polymer Composites
Żeromskiego 116, 90-924 Łódź, Poland
Phone: +48 042 631 33 17

Fax: +48 042 631 33 18

E-mail: anna.bednarowicz@dokt.p.lodz.pl

INNOVATION OF BAUHAUS TEXTILE DESIGNERS AS INPIRATION FOR CONTEMPORARY TEXTILE DESIGN

Ines KATIĆ KRIŽMANČIĆ; Koraljka KOVAČ DUGANDŽIĆ & Martinia Ira GLOGAR

Abstract: *Bauhaus, College of design and architecture, has been inspiring for more than a hundred years after its founding. Today the word Bauhaus isn't longer translated, it became an international concept and brand. During its opening the program, based on the Constitution of the Weimar Republic, enabled women unrestricted freedom of education. However, deeply rooted gender conditionality, majority of female students enrolled directly to the textile workshop. Student and later head of the textile workshops Ms. Otti Berger, originally from Croatian Baranja, is credited that the original workshop of "making pictures in textiles" has grown into a textile research workshop with an aim of tight collaboration with industry. The designers of the new age are just as revolutionary as well as former students of the Bauhaus. They are exploring, breaking stereotypes, creating new materials, joining science, biological engineering, technology and art. Inspired by the work of Bauhaus Textile workshop and with a desire to revitalize Croatian textile industry, a mini collection of useful objects was created. Collection was made in the combination of silk woven fabric and some leather details.*

Keywords: *bauhaus, textile designers, bauhaus students, influence of Bauhaus, contemporary textile design*

1. Changes in all segments of life

The first two decades of twentieth century were more closely related to the tradition of the nineteenth century, while the beginning of a new modern era began in twenties. The Industrial Revolution brings changes in all segments of life. Options which now provide technical civilization are related to the boom period of machines, cars, planes, media, especially film, newspapers and radio [1]. Accumulated capital, at the same time begins to accumulate leisure time. There are new types of entertainment: sports, travel, functional architecture and pragmatic ways of dressing. The attraction of new forms of entertainment, including sports and travel, automatically has given rise to consumption. Spending was encouraged by new forms of advertising, the invention of neon signs. *Assisted innovation, years between 1923 and 1929 with reason called "golden years"* [1]. Another two decades of the twentieth century significantly transformed the world than many previous centuries. For the first time Europe was found in the middle of two new powers, America and Russia, which will significantly affect the stability of the centuries-old tradition of West. While on the one hand Europe follows what's happening on the west side in US, the land of unlimited possibilities, on the other hand has eyes, cautiously and astonished, lays on events caused by social experiment in Soviet Union, on the east [1]. New East and New West still were not indigenous creations. The legacy of the old lady Europe, certainly has been presented in all aspects of society [1]. In these circumstances, with less available direct experience, considerable increases interest in reportages and all types of travel records. Time after First World War contributed to a new central ideas of the epoch, individualism and sensibilities of the nineteenth century were abandon, in favour of sense of power and creative power of communion [1]. Appear the new terms, which will mark the most of the next decade, the terms of many, team, collective and mass. In this way, today's ever-present term, globalization was created and founded.

2. The Weimar Republic, birthplace of Bauhaus

Weimar Republic was Germany's first republic, created in Berlin on November 1918 after the departure of the emperor in exile. It was created in very unfortunate conditions and it has come to an end, under the guise of legality, after Hitler's National Socialist Party took power in 1933 *"Completely was unexpected that the Weimar Republic, from a tough start and terrible end, rise a period of extraordinary cultural vibrancy in period of European modernism of the twentieth century"* [1].

In Weimar, on 12th April 1919, a new institution with an intention to achieve a synthesis of art and crafts based on modern principles has been established by connecting the Academy of Fine Arts and the School of Applied Arts [1]. The name of this institution will leave a deep mark influential after a hundred years. Bauhaus "house" for the theory and practice of design and construction [2]. From the very beginning at the head of the Bauhaus was Walter Gropius, already well-known and famous German architect. Around him he gathered like-minded people, foreign and local artists and theoreticians, most of them leading painters of the twentieth century. The realization of the concept of Bauhaus in the fifteen years of its existence was the synthesis of the work and

cooperation of distinctive creative personality, which are primarily: Gropius, Vasijij Kandinsky, Paul Klee, Lyon Feininger, Oskar Schlemmer, Johannes Itten, Laszlo Moholy-Nagy, Ludwig Mies van der Rohe and others. Bauhaus has become more than a school, it was a community, an entire spiritual movement with a radical approach. It was almost a philosophical center, as in ancient time *Epicurus' garden* [1].

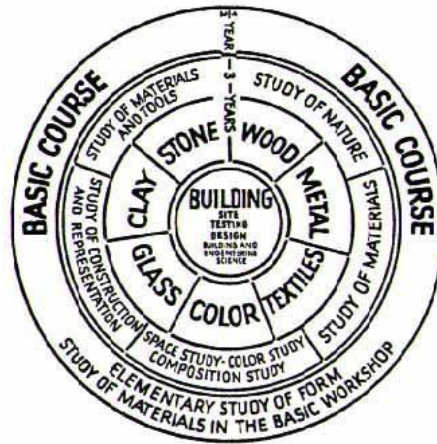

Figure 1: Schematic diagram of the study course and workshops at Bauhaus [2]

3. Bauhaus workshops

Gropius was surprised with an interest in equal number of men and women for a new school. On the basis of the new Constitution of the Weimar Republic, which women allows unrestricted freedom of education, causes that women are also enrolling in art school. Despite the constitutionally guaranteed rights for women their lives were impeded whenever possible. Female students are forced to enrolling directly in Textile workshop, marked as female workshop [3]. The only workshop which has worked continuously since founding 1919 till the closure in 1933 was a Textile workshop [2].

3.1 Textile workshop

Despite the Bauhaus reputation was as extremely advanced, modern and liberal study program, in practice existed hierarchy especially noticeable in the case of textile workshop. This was probably so because the weaving has always considered as extremely women's work. Inside the historical division of the social world, classification on male and female occupations, weaving came under extremely feminine occupation. Thus, the master of the Bauhaus workshops wall painting, Oskar Schlemmer mocked: "*Where's wool, there is a woman who weaves, even for fun*" [3].

Although the proclamation of Bauhaus, at the very beginning of the school and in its statute had specified gender equality and impartiality, unfortunately that was not the practice. A year after moving into the new building and the new address in Dessau in 1926 the workshop leads, former student and now a master, Gunta Stölzl [2]. Parallel with the transition to new location in Dessau she was changing the program of the workshop. Thanks to the new market conditions, Gunta Stölzl began to promote cooperation with the industry and the production of samples and prototypes toward to needs of industrial production. Under the new program, school and Textile workshop orientated to the development of prototypes for textiles intended architecture. The works coming out of the workshop considered extremely advanced. They emphasized pragmatism in the protection of heat and light insulation [4]. Female artists who have educated, studied and left behind that important works often were committed to memory only because of the connection with their male colleagues or were not remembered at all. Finally it is time, after more than a hundred years since founding of the Bauhaus, to acknowledge their equal contribution in the development of the Bauhaus. Departments of photography, textiles and ceramics have attended also one of the few artists from Croatian region: Ivana Tomljenović Meller, Otti Berger and Stella Skopal. Although little is known about them. They were together, with other artists, in the center of new artistic thinking and avant-garde design. Ivana Tomljenović Meller, artist from Zagreb, enrolled the Bauhaus in 1929. She has enriched Croatian culture with their posters, photographs and collages, and also continued the idea of Bauhaus as a teacher of art education. Stella Skopal attended the ceramic department at the Bauhaus. Later she was a high school teacher. With the skills in ceramics she was a pioneer of production ceramic jewellery in Croatia.

3.2 Otti Berger

Otti Berger was born in a small eastern Croatian city Zmajevac (in Baranja). She was one of the most creative member of the Textile workshop with much more expressive and conceptual approach then lot of her contemporaries. She replaced Gunta Stölzl, in a place of Head of Department in 1931, but only for a year. Then she opened their own textile studio in Berlin and applied for a visa with the intention to move to the US. She would like to join a new school of Bauhaus, leaded by Moholy-Nagy in Chicago, with attention of escaped Hitler's regime [4]. While she was waiting for approval, she came back to Croatia. Unfortunately she was arrested by Nazis and taken to Auschwitz where she died in 1944. Today here fabrics are part of the collection of Met and the Art Institute of Chicago. "She was one of the rare designers who patented own designs and textiles under the brand o.b." [4]. In her small laboratory she has constantly tested the fabrics possibilities and behaves in exploitation. Exploring opportunities, combining natural fibres with other materials she was trying to provide the all possibilities and design solutions. She also patented double fabric, "Doppelgewebe" [4] latter often used in many vehicles. What is important to emphasize, experimenting with new materials, their application in practice, exploring the characteristics of individual yarns and textile realizations put Otti Berger in forefront of textile research in period between two world wars.



Figure 2: a) The documents on patents Doppelgewebe [4], b) Catalogue with fabric patterns [4], c) Otti Berger [5]

4. Design inspired by Bauhaus

Today, design is all around us. The designers of the new age are just as revolutionary as former students of the Bauhaus. They break through stereotypes and common values, explore new materials, combine science, biological engineering, technology and art. Different principles of design deals with contemporary designer as Iris van Herpen who creates clothing of 3D print material, and producing so avant-garde garments [6]. Paulina van Dongen in her design studio produces "solar clothes", which create additional energy and using it we can recharge our cell phones [7]. Chinese designer Lining Yao, perhaps the most revolutionary one, creates vivid clothes, a biological design now most dedicated to the athletes. Apparel coated with live bacteria cells are sensitive to physical stimulus and the humidity. Using 3D printers she sticks bacteria to the material. These living organisms can act as sensors, activated when they sense moisture, excessive perspiration athletes [8].



Figure 3: a) Design, Iris van Harpen [6], b) Solar jacket, Paulina van Dongen [7], c) Lining Yao, Bacteria 3D print [8]

5. Collection in silk

Unique collection in silk with leather details was created on the trail and inspired by Bauhaus. It was created with a desire to include, in the style of Bauhaus, the whole process from: idea, inspiration, art solutions for the textile realization, concepts for products, and participation in the production process, packaging and the possibilities for market position.

5.1 Silk

In our fields even at the time of Empress Maria Theresa was planted thousands of mulberry trees that accompanied today's highway A3 from Zagreb to Slavonski Brod. Silk is unfortunately no longer grown anywhere in Europe. All of the world's silkworm rearing is restricted to the Chinese and some Latin American regions. Soybean silkworms are extremely environmentally sensitive and thus highly endangered by increasing pollution in China. Europe should seriously consider revitalizing the cultivation of mulberry silk on its areas.

5.2 Realised silk fabric

Design was created in a computer program. Selected design was made on jacquard machine in quality of 100% silk. Warp density was in 90 threads and weft density in 112 threads per cm. The warp based in nine different colours while the weft consists seven different colour that finally results with total of sixty three different colour variants of designs no.8782T. Silk fabric was realised in cooperation with weaving factory in Italy.

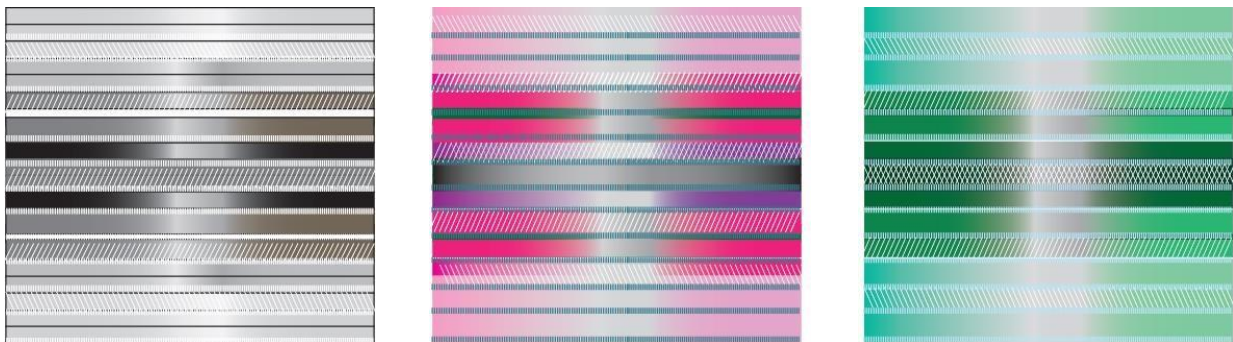

Figure 4: Template of colour variants, made in graphic program, by Ines Katić Križmančić

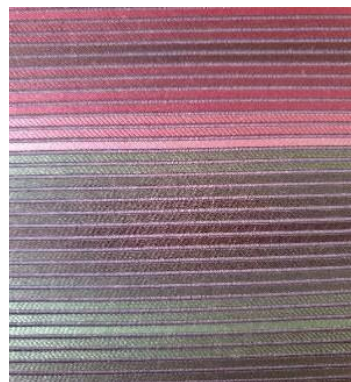

Figure 5: Weaved colour variant of design 8782T, photo by Ines Katić Križmančić

5.3 Collection

Collection consist five products, two cosmetic bags and three key ring. Models were drafted in the graphics program. Production was realized in cooperation with Croatian leather Co. Galcko d.o.o.

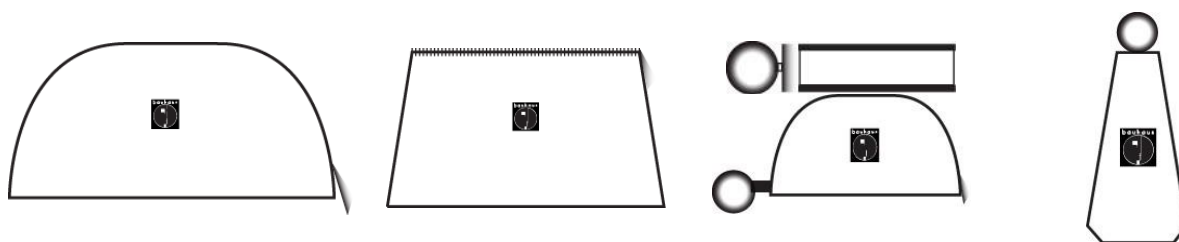

Figure 6: Draft models made in graphic program, by Ines Katić Križmančić



Figure 7: Realized collection in silk fabric with leather details, photo by Ines Katić Križmančić

6. Conclusion

During the Bauhaus time subject of the study was how the unique handmade item prepare to the products ready for multiplication and industrial production. At the present time, especially in Croatia, the challenge is to raise awareness about preserving the unique hand-crafted items. Unique and handmade products are valued more in developed countries, which after flooding mass production, seek their identity in a sea of global uniformity. Therefore, unique works and hand-crafted items most value, in one of the most developed country of the world, Japan. Charm, originality and personal touch of composing hands woven into the artefact, tell stories about the magic of creation and turning dreams into tangible reality. But there is something even more important, unique and handmade work could return mental and spiritual balance, lost attention, awareness, presence and love for what we do. That is unusually important at times when our focus and attention are seriously endangered by unrest caused of new virtual reality.

References

- [1] Žmegač, V.: *Od Bacha do Bauhaua, Povijest njemačke kulture*, Matica Hrvatska, biblioteka Peristil ISBN: 9789531507912, Zagreb, (2006)
- [2] Winkler, K.: *Bauhaus Alben 3*, Verlag der Bauhaus-Universitat, ISBN: 978-3-95773-023-7, Weimar (2008)
- [3] Droste, M.: *The Bauhaus 1919 – 1933.: Reform and avant-garde*, Tashen, ASIN: B00E7G657A, Köln, (2006)
- [4] Mlikota, A.: *Otti Berger – Hrvatska umjetnica iz Tekstilne radionice Bauhaua*, *Radovi Instituta za povijest umjetnosti Sveučilišta u Zadru*, (2009) 33, pp. 271-282, ISSN: 0350-3437
- [5] Kiš, P.: *Otti Berger tragičan kraj iznimno talentirane lijepe i omiljene dizajnerice kojoj se divio i Alvar Alto*, Available from: <https://www.jutarnji.hr/kultura/art/otti-berger-tragican-kraj-iznimno-talentrane-lijepe-i-omiljene-dizajnerice-kojoj-se-divio-i-alvar-aalto-8352071> Accessed: 2019-08-08
- [6] Iris Van Herpen web site, Available from: <https://www.irisvanherpen.com/> Accessed: 2019-08-10
- [7] Pauline Van Dongen web site, Available from: <https://www.paulinevandongen.nl> Accessed: 2019-09-12
- [8] Yao, L.: *Morphing matter lab*, Available from: <https://morphingmatter.cs.cmu.edu/lining-yao> Accessed: 2019-09-01

Authors:

Ines Katić Križmančić, mag. ing. des text, Ph.D. student (corresponding author)
University of Zagreb Faculty of Textile Technology
Prilaz baruna Filipovića 28 a, 10000 Zagreb, Croatia
Tel.: +385 91 229 4964

E-mail: ikatickri@tff.hr

Assoc. prof. art. Koraljka Kovač Dugandžić
University of Zagreb Faculty of Textile Technology
Prilaz baruna Filipovića 28 a, 10000 Zagreb, Croatia
Tel.: +385 1 3712 548

E-mail: koraljka.kovac@tff.hr

Prof. Martinia Ira Glogar, PhD.
University of Zagreb Faculty of Textile Technology
Prilaz baruna Filipovića 28 a, 10000 Zagreb, Croatia
Tel.: +385 1 3712 557

E-mail: martinia.glogar@tff.hr

AGRO-WASTE AND EASILY RENEWABLE PLANTS AS SOURCES FOR NATURAL SILK DYES

Anja LUDAŠ; Suzana VIDEK & Ana SUTLOVIĆ

Abstract: *In this paper, the possibility of using wastes and readily renewable vegetable raw materials as a source of natural dyes for silk is examined. The following plants were used: camomile flowers, onion skins, walnut and ash bark. Considering they are dyes from the group of mordant dyes, potassium aluminium sulphate dodecahydrate, copper(II) sulphate pentahydrate, iron(II) sulphate heptahydrate are used as mordant. Silk was chosen as the material because of the tradition in Croatia and the attempt to revitalize cultivation. Results of this research are presented through the analysis of CIELAB colour values based on spectrophotometric measurement. The final colour map was used to colouring silk scarves inspired by circles in grain. Bio-wastes have the attention of researchers as a source of natural textile dyes due to their ecological background, abundance and availability at minimal costs.*

Keywords: *natural dyes, silk fabric, mordant, wastes, camomile, onion, ash, walnut*

1. Introduction

Ever since the prehistoric time, mankind took delight in colouring the objects of daily use by employing natural pigments of vegetable, animal, and mineral origin. These colouring substances, known as natural dyes, are the chemical compounds used for colouring fabrics, hair, leather, paper, food items, cosmetics, and medicines, etc. People always prefer natural dyes and pigments because of their brightness, soothing and non-toxic nature [1]. Natural dyes are mostly non-substantive and have to be applied on textiles by the using of mordants, usually a metallic salt, having an affinity for both the colouring matter and the fibre [2]. Very few substantive dyes like indigo, cochineal, turmeric, walnut hulls and onion skins can be dyed without the use of mordant [3]. Worldwide, growing consciousness about organic value of eco-friendly products has generated renewed interest of consumers towards use of textiles (preferably natural fibre product) dyed with eco-friendly natural dyes. Natural dyes produce very uncommon, soothing and soft shades as compared to synthetic dyes. On the other hand, synthetic dyes, which are widely available at an economical price and produce a wide variety of colours, sometimes causes skin allergy and other harmfulness to human body, produces toxicity/chemical hazards during its synthesis, releases undesirable/hazardous/toxic chemicals etc. [2]. Natural dyes has nutritional point of view as few of the carotenoid pigments are helpful in prevention of few forms of cancers and few are vitamin A precursors, which may be effective antioxidants. Efforts should be made to promote the use of natural dyes, extend the range of their application, and encourage their commercial use rather than restricting them to small scale cottage industries. There is a need to carry out research and development on natural dyes by using modern technology to develop extraction techniques, standardize applications on synthetic as well as natural fibers as well as leather [1].

One of the main objectives of this research was to investigated agro-waste as source of natural dyes for textile application. Agriculture, food industry and timber industry produces large volumes of wastes, both solids and liquids, resulting from their cycle of production. These wastes pose increasing disposal and potentially severe pollution problems and represent a loss of valuable biomass and nutrients. In the other hand, these wastes have attracted the attention of researchers as a source of natural textile dyes due to their abundance and availability at minimal costs. Additionally, their uses can promote the idea of “zero emissions”, based on the concept that wastes from one industry can be converted to raw material for another one, along with the added economic value to those wastes and minimizing their inherent environmental impacts [4]. Silk was chosen as the material because of the tradition in Croatia and the attempt to revitalize cultivation.

2. Experimental

2.1. Textile Material

The studies were carried out on degummed silk. Degumming is a process during which sericin is totally removed and silk fibres gain the typical shiny aspect, soft handle and elegant drape, such a product is suitable for the dyeing process. Surface mass of silk fabric was 90 g/m².

2.2. Mordanting Process

Textile materials were treated in solution of selected metal salts. Considering they were natural dyes from the group of mordant dyes, potassium aluminium sulphate dodecahydrate $KAl(SO_4)_2 \cdot 12H_2O$ (Kemika, Zagreb), copper(II) sulphate pentahydrate $CuSO_4 \cdot 5H_2O$ (Kemika, Zagreb), iron(II) sulphate heptahydrate $FeSO_4 \cdot 7H_2O$ (Kemika, Zagreb) are used as mordant. Pre-mordanting was performed at material to liquor ratio of 1:20 at 100 °C for 60 min, with the mordant addition of 2 % (owm - on the weight of material). Acidic conditions, pH 4, are ensured by the addition of tartaric acid ($C_4H_6O_6$) (Kemika, Zagreb).

2.3. Natural dye extraction

The following plants were used: camomile flowers, onion skins and ash bark; the pigments obtained from them are from the flavonoid group, while juglon is obtained from walnut. The natural dye was extracted by boiling at 100 °C for 1 hour, considering to the mass of the plant to liquor ratio of 1:50. After cooling, the aqueous extract is filtered and stored in a refrigerator.

2.4. Dyeing Process

Silk fabric dyeing process was carried out in a laboratory type machine Polycolor, Mahtis, by exhaustion method and with material to liquor ratio of 1:20 at 40 °C for 120 min due to further the batik technique application. Dyeing was performed with and without mordanting process. After dyeing process, the coloured samples were thoroughly washed with soaping.

2.5. Colour Fastness Testing

Dyed samples were tested to wash fastness. Wash fastness test was performed in a laboratory type machine for wet and dyeing processes Polycolor, Mathis, according to standard EN ISO 105 - C06: 2010: Textile - Color fastness test - Part C06: Stability of dyeing inhousehold and commercial washing. The washing bath contained 0.5 g/l nonionic surfactant Kempon 30 (CHT Bezema) with liquor ratio 1:30 at 30 ± 2 °C and pH 6 for 30 min. The results of colour fastness have been obtained objectively and are presented as total colour difference values (dE) calculated according to CIELAB (CIE76) formula.

2.6 Colour measurements

Results of this research are presented objectively through the analysis of colour values (colour hue (h), chromaticity (C^*) and lightness (L^*)) based on spectrophotometric measurement and are shown in a^*/b^* colour space. Remission spectrophotometer DataColor Spectra Flash 600 PLUS – CT (with constant instrument aperture, D65, using $d/8^\circ$ geometry) was used. The Kubelka-Munk coefficient (K/S) was calculated in terms of K/S values using the Kubelka-Munk equation (1) as the definition of colour depth. Where K is the absorption coefficient, S is the scattering coefficient, and R is the reflectance of the dyed fabric at the wavelength of maximum absorption.

$$K/S = (1 - R)^2/2R \quad (1)$$

For fastness properties analysis, the results are presented as total colour difference values (dE_{CIE76}) obtained by measuring and comparing the samples before and after the fastness testing. Colour difference values were calculated using formula (2), defining the samples before fastness tests as reference samples.

$$dE_{CIE76} = ((dL^*)^2 + (dC^*)^2 + (dh^*)^2)^{1/2} \quad (2)$$

2.7 Designer realization

The final colour map was used to realize the design realization, silk scarves inspired by circles in grain. After pre-treatment, the realization of batik and plangi techniques is started. Wax is applied to the fabrics in selected shapes, and the selected parts are joined with twine of different thicknesses. In this way, the colors and shapes mimic the motif - circles in grain.

2.8 Batik and plangi technique

Batik technique is a combination of printing and dyeing. The pattern is drawn in such a way that the wax overlaps the parts that must retain the current color of the substrate. Then the fabric was dyed in the extract of natural dyes. After dyeing, the fabric dries and is further covered with wax parts that must retain the colour

and continue to be dyed in the next colour. The procedure is repeated until all the effects have been completed. The combination of beeswax and paraffin can influence the quality of the batik effect (ratio 1:1). After dyeing process, the wax is removed by washing at a temperature higher than the melting temperature of the wax. The plangi technique is based on making a reserve by tying certain pieces of fabric with ribbons or thread to give a secluded effect during dyeing of the fabric.

3. Results and discussion

3.1. Dyed samples

Pre-treatment of the silk fabric with various metal salts (without, Al, Cu, Fe) and plants (walnut, onion skins, camomile flowers and ash bark) resulted in a wide range of colour hues. Camomile dyed silk obtained a yellow hue, ash dyed silk has a light brown hue, onion dyed silk has a red-brown hue, walnut dyed silk has a dark brown hue. Al samples dyed with pre-treatment of the Fe metal salt have dark brown colour hue (Table 1).

Table 1: Colour map; (Labels: plants (C_camomile flowers, A_ash bark, O_onion skins and W_walnut) _ pre-treatment of the silk fabric with various metal salts (without, Al, Cu, Fe))

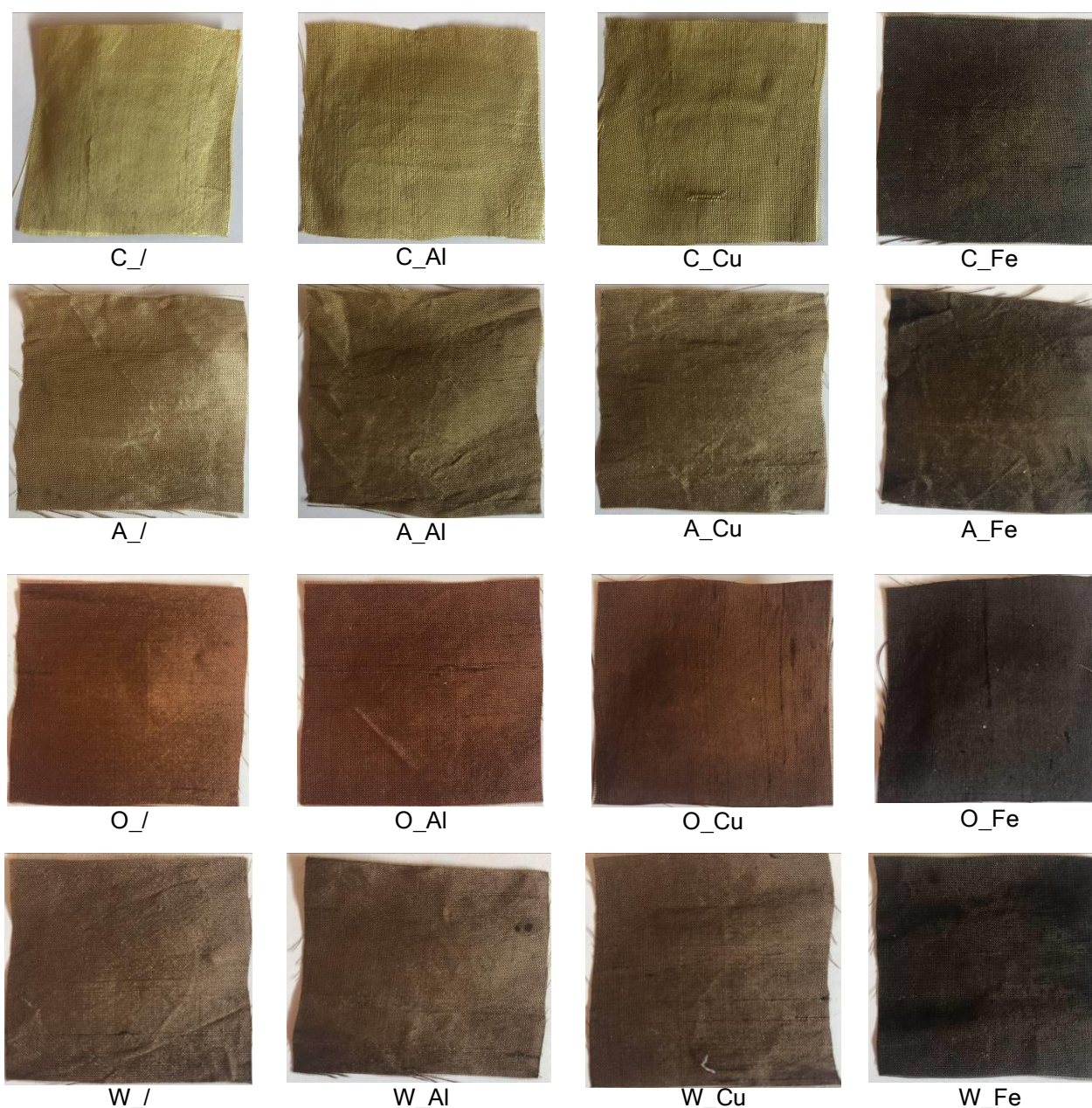

According literature [5], the substances responsible for the colouration are luteolin (camomile), quercetin (onion), rutin (ash), juglon (walnut), Figure 1.

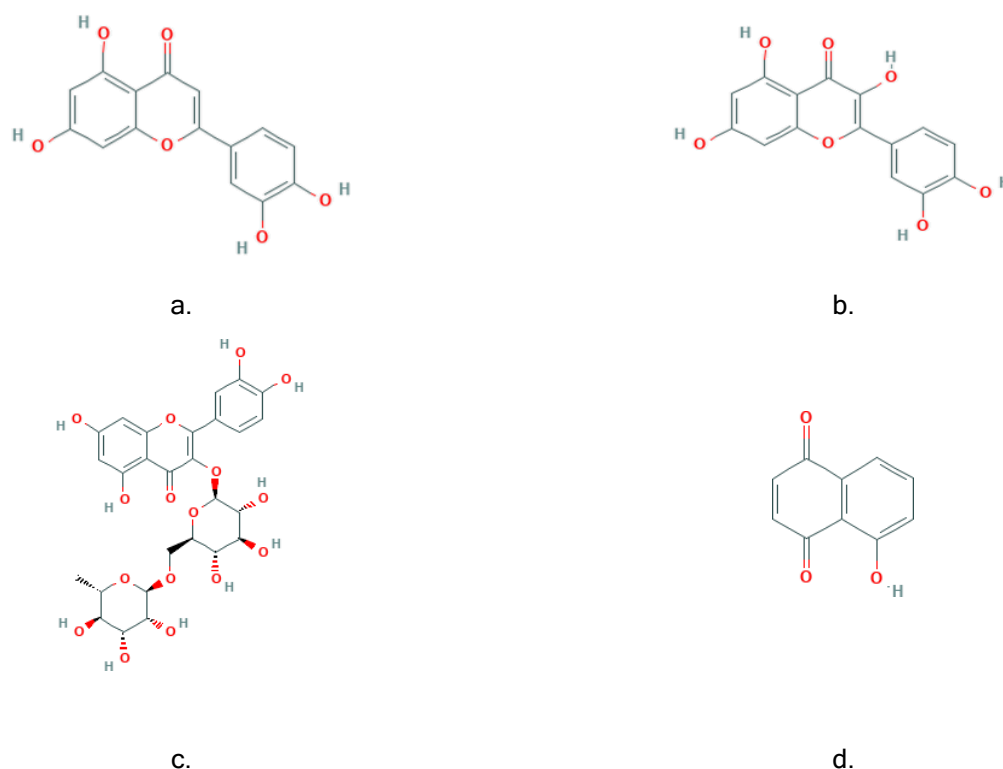

Figure 1: Structures of the substances responsible for the colouration: luteolin (a.), quercetin (b.), rutin (c.), juglon (d.) [6]

3.2. Colouration objective analysis

Objectively analysis of dyes samples according to CIELAB system and through Kubelka-Munk coefficient is shown in Table 2.

Table 2: Colour values (colour hue (h), chromaticity (C*) and lightness (L*)), a*b* coordinates (CIEL*a*b* system) and Kubelka-Munk coefficient (K/S).

Samples	L*	a*	b*	C*	h	K/S
C /	70.49	1.24	34.20	34.22	87.93	7.32
C_Al	67.68	2.17	31.93	32.00	86.11	6.60
C_Cu	67.63	1.93	36.33	36.38	86.96	8.80
C_Fe	31.74	3.53	14.02	14.46	75.86	15.21
A /	64.40	5.25	21.49	22.13	76.26	4.58
A_Al	56.39	6.38	25.29	26.08	75.83	8.22
A_Cu	58.05	6.41	23.60	24.46	74.80	6.40
A_Fe	34.35	5.26	13.26	14.27	68.38	13.98
O /	42.86	20.16	26.99	33.69	53.24	14.16
O_Al	34.53	19.60	20.49	28.36	46.27	15.99
O_Cu	30.88	16.38	18.06	24.38	47.79	17.13
O_Fe	22.46	4.86	4.66	6.74	43.83	16.45
W /	42.69	9.15	13.11	15.99	55.06	7.82
W_Al	42.55	9.86	14.76	17.75	56.25	8.92
W_Cu	41.34	9.83	13.96	17.08	54.84	8.85
W_Fe	30.15	5.25	6.43	8.30	50.78	12.00

Camomile dyed silk obtained a yellow hue (h=75-87), ash dyed silk has a light brown hue (h=68-76), onion dyed silk has a red-brown hue (h=43-53) and walnut dyed silk has a dark brown hue (h=50-55). All samples are in the first quadrant (0° - 90°, red – yellow). After pre-treatment of the silk fabric with various metal salts (Al, Cu) and without mordant the chromaticity and the brightness value increases, but with metal salt Fe decreases. It is observed that the subjective experience of the colour palette is wider than the objective because the

subjective experience is the result of a combination of tone, brightness and chromaticity. The silk dyed with onion skins extract has the highest colour intensity (K/S coefficient) with and without mordants. All four samples (camomile flowers _C, ash bark _A, onion skins _O and walnut _W) have the highest K/S after pre-treatment of the silk fabric with metal salt Fe and the lowest colour intensity without metal salts.

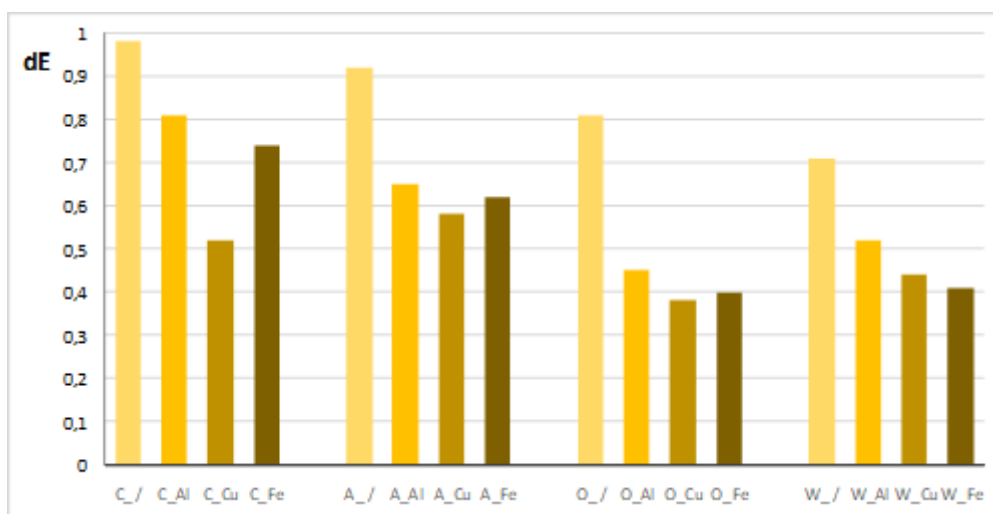

Figure 2: Effect of mordants on wash fastness

Based on the results shown in Figure 2, it can be seen that the samples have excellent resistance to washing, ie. $dE < 1$. The use of metal salts further increases the stability, which confirms that in addition to ionic, coordination bonds are formed. Excellent stability in very deep colours confirms the acceptance of process parameters as well as the stability of the formed metal complexes.

The pre-mordanting process with the metal salts was carried out at pH 4. During the pre-mordanting and dyeing process, a chelate fiber-metal ion-natural pigment is formed. In addition, according to the amphoteric character of the protein, in the acidic medium the protonization of the amino group occurred and the formation of ionic bonds via the ionized carbonyl group of natural pigments was ensured. The combination of different metals and natural pigments results in metal complexes of different colours.

3.3 Colour map

The final colour map was used to realize the design realization, silk scarves inspired by circles in grain. Inspiration and creative realization are shown in Figure 3.

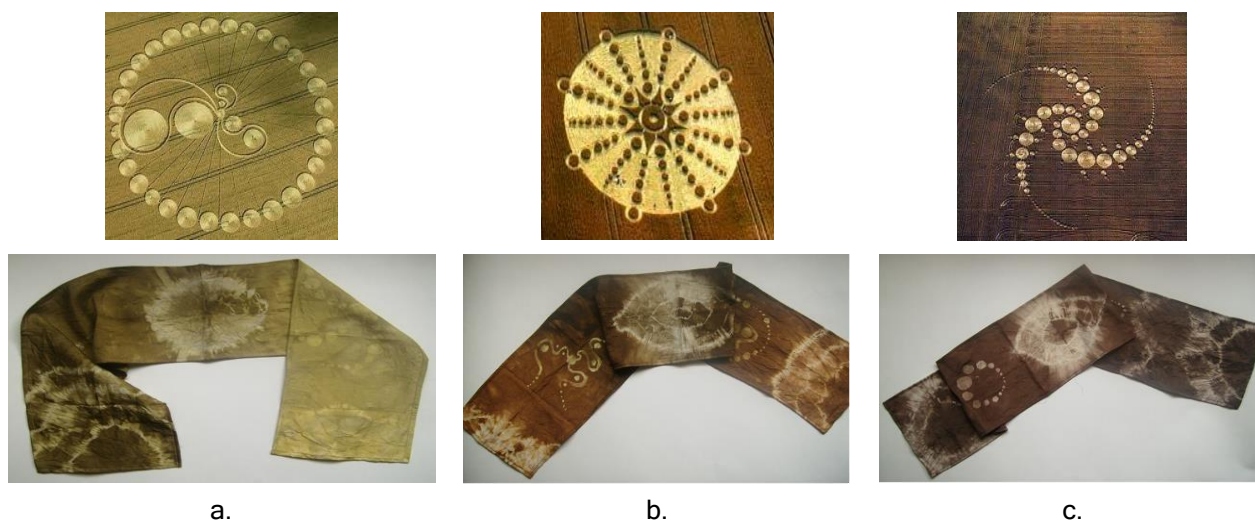

Figure 3: Silk scarves dyed with extract of the camomile flowers (a.), onion skins (b.) and walnut (c.)

The final phase of the work was a synergy of creativity and technology. Based on the colour map, recipes for colouring scarves are defined (table 1). The combination of colours and shapes, achieved by batik and plangi

techniques, resulted with pattern according to inspiration (figures 3). Soothing and soft shades of shawls are well matched with the colour palette of nature, and using old batik and plangi techniques, characteristic patterns have been obtained.

4. Conclusion

In the study, camomile flowers, ash bark, onion skins and walnut extract were used for colouring silk fabric. These natural wastes have attracted the attention of researchers as a source of natural textile dyes due to their ecological value, abundance and availability at minimal costs. Additionally, their uses can promote the idea of “zero emissions”, based on the concept that wastes from one industry can be converted to raw material for another one. Considering they were natural dyes from the group of mordant dyes Al, Cu and Fe are used as mordant. Silk was chosen as the fiber because of the tradition in Croatia and the attempt to revitalize cultivation. Al four samples are in the first quadrant (0°- 90°, red – yellow, h= 43-87). After pre-treatment of the silk fabric with various metal salts (Al, Cu) and without mordant the chromaticity and the brightness value increases, but with metal salt Fe decreases. The silk dyed with onion skins extract has the highest colour intensity (K/S coefficient) with and without mordants. The final colour map was used to realize the design realization, silk scarves inspired by circles in grain. The synergy of technologists and designers is important in realizing such concepts.

References

- [1] Singh H. B. and Bharati K. A.: *Handbook of natural dyes and pigments*, Woodhead Publishing India Pvt. Ltd. ISBN: 978-93-80308-54-8, First published New Delhi (2014)
- [2] Ashis Kumar S. and Konar A.: *Dyeing of Textiles with Natural Dyes*, Department of Jute and Fibre Technology, Institute of Jute Technology, University of Calcutta India (2011)
- [3] Amutha K. and Grace Annapoorani S.: Natural dye extraction from agro-waste and its application on textiles, *Article in Asian Dyer* (2019)
- [4] Baaka N., et al: Wool dyeing with extracts from agro industrial wastes: A boost to sustainability, *International journal of applied research on textile*, Vol. 5, No. 2, pp 16-25, December (2017)
- [5] Schwepe, H. *Handbuch der Naturfarbstoffe: Vorkommen, Verwendung, Nachweis*, Ecomed, Landsberg am Lech, 1992
- [6] Pub Chem: <https://pubchem.ncbi.nlm.nih.gov/>, accessed 10.2.2020.

Authors:

Assistant Anja LUDAŠ, B. Sc. (corresponding author)
University of Zagreb Faculty of Textile Technology
Prilaz baruna Filipovića 28a, 10000 Zagreb, Croatia
Phone: +385 91 7317993

E-mail: anja.ludas@tff.unizg.hr

Suzana VIDEK, B. Sc.
University of Zagreb Faculty of Textile Technology
Prilaz baruna Filipovića 28a, 10000 Zagreb, Croatia
Phone: +385 91 1619 087

E-mail: suznavidek@gmail.com

Assoc. prof. Ana SUTLOVIĆ, PhD.
University of Zagreb Faculty of Textile Technology
Prilaz baruna Filipovića 28a, 10000 Zagreb, Croatia
Phone: +385 91 5470271

E-mail: ana.sutlovic@tff.unizg.hr



**Presentation of selected scientific projects of the
University of Zagreb Faculty of Textile Technology**



DEVELOPMENT AND THERMAL PROPERTIES OF INTELLIGENT CLOTHING

Project leader: Prof. Dubravko Rogale, Ph.D.

Project associates: Prof. Siniša Fajt, Ph.D., Prof. Snježana Firšt Rogale, Ph.D., Prof. Antoneta Tomljenović, Ph.D., Assist. Prof. Željko Knezić, Ph.D., Assist. Prof. Kristina Krulić Himmerleich, Ph.D., Assist. Prof. Emilija Zdraveva, Ph.D. and Ph.D. students: Martina Bobovčan Marčelić, Daniel Časar Veličan, Nikolina Jukl

Duration: 1 January 2019 - 31 December 2022

Value: 828.100,00 HRK

The scientific area and field: Technical sciences, Textile technology

Keywords: intelligent clothing, prototype, sensors, actuators, microcontrollers, thermal properties, welding methods

Abstract: A team of scientists of the Faculty of Textile Technology is dealing with the development of intelligent clothing with adaptive thermal insulation properties. They have developed and patented two generations of prototypes where sensors monitor the state of the outdoor environment and the microclimate of intelligent clothing. The integrated computer interprets the existing situation, and it makes decisions about necessary changes so that the article of clothing intelligently responds and automatically adapts its thermal properties in accordance with the environment and physical activities of the wearer. Initial research activities and development have shown the justification of introducing the concept of intelligent clothing, while prototypes and parts of metrology equipment have been recognized by the innovation community with awards. The objectives of this project are to improve the architecture of the sensor-computer-actuator system, to design new ergonomically shaped segmented thermal insulation chambers and technical subsystems using high-tech welding methods, and to create a new generation of intelligent clothing prototypes.

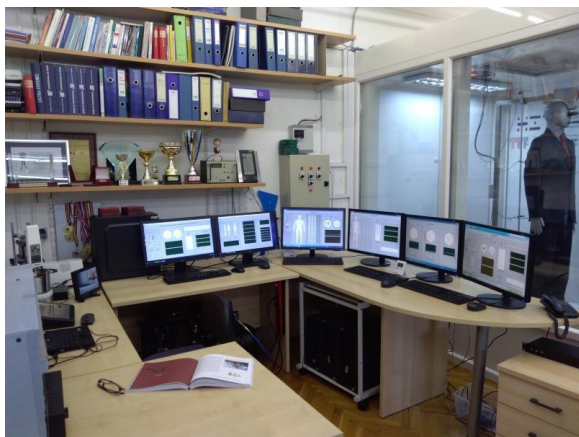

The operation and characteristics of the technical subsystems and the reaction rate of intelligent clothing will be investigated. A new research laboratory for complete measurements of thermal properties of clothing shall also be established. The integration of metrology subsystems will be performed in the new climatic chamber. On the basis of these research activities, the final optimization of the reactions of intelligent clothing will be performed, and its properties in changing environmental conditions under laboratory conditions and during physical activities of the wearer will be determined. The final objective of this project is to create a sophisticated prototype, to study the properties of new kinds of intelligent clothing, and to establish a new laboratory for testing the thermal properties of all types of clothing.

Acknowledgment

This presentation was funded by the Croatian Science Foundation through the project IP-2018-01-6363 Development and thermal properties of intelligent clothing (ThermIC).



COMFORT AND ANTIMICROBIAL PROPERTIES OF TEXTILES AND FOOTWEAR (IP-2016- 06-5278)

Project leader: Prof. Zenun Skenderi, Ph.D.

Project associates: Prof. Alka Mihelić-Bogdanić, Ph.D., Prof. Zlatko Vrljičak, Ph.D., Prof. Antoneta Tomljenović, Ph.D., Assoc. prof. Sanja Ercegović Ražić, Ph.D., Assoc. prof. Dragana Kopitar, Ph.D., Assist. prof. Tomislav Ivanković, Ph.D. Jadranka Akalović, dipl. ing. Prof. Lubos Hes, Ph.D., Technical University of Liberec, Beti Rogina Car, Ph.D. Assist. prof. Ivana Špelić, Ph.D., Željka Pavlović, mag.ing.techn.text. Franka Žuvela Bošnjak, mag.ing.techn.text. Suzana Mihanović, dipl. inž., Jelena Peran, mag.ing.techn.text., Juro Živičnjak, mag.ing.techn.text., Ivan Kraljević, mag.ing.techn.text., Tariq Mansoor, Ph.D. Student of Technical University of Liberec

Duration: 1 March, 2017 - 29 February, 2022

Value: 624,100 kn

The scientific area and field: Technical, Textile technology

Keywords: Textile, knitted fabric, socks, regenerated cellulose fibers, footwear, leather, comfort, antimicrobial properties, Viscose, Modal, Tencel, cotton, PES

Abstract: Comfort of textiles for making garments worn next to the skin, for a specific type and level of activity and environmental condition is mainly determined by the type of raw material, type of yarn and knitted fabric structure. To differentiate the level of comfort and to propose a greater benefit, knitted fabrics made from single tricot yarns (ring-spun, rotor-spun and aerodynamic), SIRO yarn are used. Yarns (ring, rotor and air-jet) are spun from regenerated cellulosic fibres: Viscose, Tencel, Modal and micro Modal fibres. Knitted fabrics for making clothing are knitted in rib construction, while hosiery are made in plain jersey, in plated construction, multiple plated and jacquard construction. Polyamide multifilament yarn is added to knitted fabrics for making hosiery (socks).

In addition to the basic structural and tensile characteristics of yarns, knitted fabrics and socks, the thermophysiological properties (thermal and water vapour resistance using Sweating Guarded Hot Plate, and Foot model) of raw and finished samples are examined. Investigations of antimicrobial treatments of knitted fabrics against pathogenic bacteria include achieving satisfactory level of antimicrobial protection, good stability under daily use and care. Knitted fabric samples are antimicrobially treated using commercial available as well as new agents applied to the material by conventional finishing procedures and using plasma as a new environmentally friendly technology in the treatment of textile materials. Leather (for front side, lining and insole) and samples of other materials for the footwear samples are tested for the properties of thermophysiological comfort as well as parameters of thermophysiological comfort.

Antimicrobial activity of knitted fabrics and leather are determined according to 3 types of bacteria (*A. baumannii*, *S. aureus* and *E. coli*). On a number of samples of leather, the Comet test will be carried out (quick detection of damage and repair in a DNA molecule).

The evaluation of performance and functional characteristics of knitted fabric, leather and multi-layered material constructions by defining durability and stability of the performed treatments of materials by simulating the conditions of application and use (by implementing repeated cycles of washing and drying, abrasion, bending and assessing colour fastness rate to different influences) will be performed.

Acknowledgment

This presentation has been fully supported by the Croatian Science Foundation under project No. IP-2016-06-5278 Comfort and antimicrobial properties of textiles and footwear.



CUSTOM TAILORED FIBROUS SCAFFOLD PROTOTYPE FOR TISSUE CELLS CULTURE VIA COMBINED ELECTROSPINNING

Project leader: Prof. Budimir Mijović, Ph.D.

Project associates: prof. Emi Govorčin Bajsić, Ph.D., Mirna Tominac Trcin, Ph.D., prof. Tamara Holjevac Grgurić, Ph.D., assoc. prof. Igor Slivac, Ph.D., assist. prof. Emilija Zdraveva, Ph.D., Ivana Vrgoč Zimić, BSc, Tamara Dolenc, BSc, prof. Iva Dekaris, Ph.D., prof. Xungai Wang, Ph.D.

Duration: 48 months

Value: 969.700,94 HRK

The scientific area and field: interdisciplinary field

Keywords: electrospun scaffolds, tissue engineering, antibiotic, TiO₂, Anti-VEGF, limbal stem cells, immunocytochemistry

Abstract: This project focuses on the development of electrospun cells scaffolds for tissue engineering, thus contributes in the problem of donors scarcity in traditional organ transplant surgery. Scaffolds should mimic the native cells surrounding, support cells adhesion, cells penetration and homogenous colonization. The technique of electrospinning is advantageous due to versatility in materials selection, fibers diameter and morphology control and complex compositions fabrication with the addition of nanomaterials to the polymer solutions or melts. The project offers solution to fabrication of electrospun scaffolds with dual structure overcoming the drawback of scaffolds intrinsic 2D structure. The final goal of the project is to develop scaffolds with optimal architecture and multifunctionality, thus introducing co-existence of several functional species. The multifunctional feature of the scaffolds comes from both antibacterial and cellular processes stimulating property.

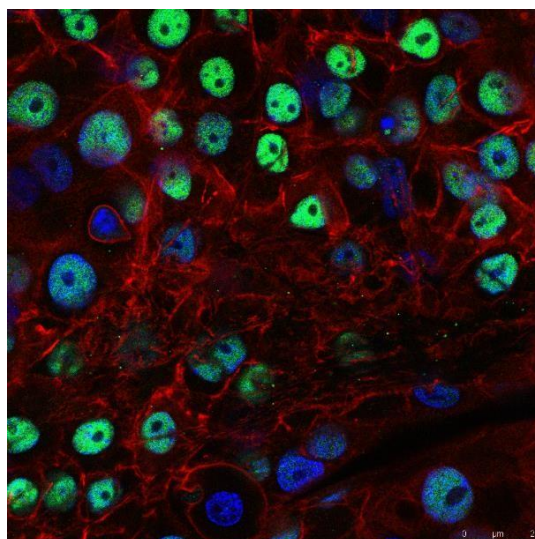

In vitro limbal stem cells growth

Acknowledgment

This presentation was funded by the Croatian Science Foundation through the project IP-2016-06-6878 Custom Tailored Fibrous Scaffold Prototype for Tissue Cells Culture via Combined Electrospinning.



PARTNERS



CONFUCIUS INSTITUTE AT THE UNIVERSITY OF ZAGREB

萨格勒布大学孔子学院



Confucius Institute at the University of Zagreb is a university educational center established in May 2012 to promote Chinese language and culture and to strengthen economic ties between the Republic of Croatia and the People's Republic of China. Establishment of the Confucius Institute at the University of Zagreb, Croatia has made an important step in strengthening cultural and educational cooperation with the People's Republic of China, and Zagreb joined the regional group of institutes together with Ljubljana, Vienna and Budapest. Selecting the Shanghai International Business and Economics University as a partner and the incorporation of the Croatian Chamber of Commerce in the Board of directors, the Institute has clearly positioned itself as one of the top five European business institutes together with those in London, Copenhagen, Ljubljana and Athens. Since 2012, Institute is conducting Chinese language courses for all ages, as well as Cultural programs such as Chinese Calligraphy, traditional Chinese painting, Chinese Chess, Weiqi, Taiji and Wushu. Programs are held across Croatia in cooperation with partner institutions like Faculty of Economics and Business (University of Zagreb), Faculty of Economics (University of Rijeka), Faculty of Economics (University of Osijek), Faculty of Kinesiology (University of Zagreb), Faculty of Humanities and Social Sciences (University of Split), Faculty of Tourism and Hospitality Management (University of Rijeka), University of Dubrovnik and University of Zadar.

Mr Krešimir Jurak, Croatian Director

Mrs Feng Min, Chinese Director

Confucius Institute at the University of Zagreb

Savska cesta 25, 10000 Zagreb, Croatia

info@ki.unizg.hr

phone: +385 (0)1 48 43 601

Confucius Institute at the University of Zagreb, Savska cesta 25, 10000 Zagreb, Croatia
www.ki.unizg.hr; info@ki.unizg.hr; phone: +385 (0)1 48 43 601

CARNET

linking knowledge

Croatian Academic and Research Network – CARNET is a public institution operating within the Ministry of Science and Education in the field of information and communication technology and its application in education. CARNET began operating in 1991 as a project of the then Ministry of Science and Technology and became the first and only provider of Internet services in Croatia. Four years later, the Government of the Republic of Croatia adopted the Decree on the establishment of CARNET institution with the aim of innovating the education system and encouraging the progress of individuals and the society as a whole through ICT.

CARNET network is a private network of the academic, scientific and research community of the Republic of Croatia, as well as the institution within the primary and secondary education system. CARNET services are available to primary and secondary schools, institutions from the science and higher education institutions, as well as to numerous public institutions such as certain ministries, hospitals, etc. More than 2600 institutions, with more than 3800 locations across Croatia, are currently connected to CARNET network. CARNET individual users are students, teachers, professors, scientists and other staff members of CARNET member institutions, and all citizens of the Republic of Croatia in the segment of security on the Internet.

Focus on users is a core motivation for more than 170 CARNET's employees in six cities – Zagreb, Rijeka, Osijek, Split, Pula and Dubrovnik – who, with their knowledge and experience, improve the daily operation of the institution.

Following the latest trends in ICT, infrastructure and education over the years, CARNET has devised a number of projects and developed new services. Currently, CARNET offers more than 70 services, from education and training to multimedia, computer security and user support. Users access all services through the electronic identity in the AAI@EduHr system.

In addition, CARNET provides user support for the systems of the Ministry of Science and Education - e-Matica and National information system for applications and enrollments into secondary schools, and within the e-Citizens system CARNET developed e-Citizens mToken credentials. CARNET's well known service is the e-Class Register – application for the management of the class register in electronic form, which is used by 95 percent of schools in the Republic of Croatia.

With the aim of building a digitally mature society, CARNET has successfully implemented, in collaboration with its partners, the pilot project “e-Schools: Establishing a System for Developing Digitally Mature Schools”, by which 10 percent of primary and secondary schools have increased the level of digital maturity. The introduction of adequate ICT infrastructure and equipment in 151 Croatian schools, the development of digital content, e-Services and tools for teaching and work processes, as well as systematic education, have enabled the regular use of technology in learning and teaching and increasing the digital competence of educational staff in schools. Based on the experience and results gained through the pilot project, CARNET launched the second phase of the programme “e-Schools: Development of the System of Digitally Mature Schools (Phase II)”, worth 1.3 billion kuna. By the end of 2022, all Croatian schools will be digitally transformed.

CARNET also manages the national domain of the Republic of Croatia (.hr), participates in a number of international activities and cooperates with other European academic and research networks, the GÉANT Association organisation and the organisations responsible for managing the internet resources in the world.

Domain:

Education / lifelong learning, Kindergarten, Primary Education, Secondary Education, General Education, Further Education, Higher Education, Corporate Training, Learning Technology Provider, Research, Social Inclusion

CARNET, Josipa Marohnića 5, 10000 Zagreb, Croatia
<http://www.carnet.hr>; ured@carnet.hr



SPONSORS AND DONORS



**HRVATSKI KLASTER
KONKURENTNOSTI**

Industrija tekstila, kože i obuće



čateks d.d.

ČAKOVEC

Since 1874



HRVATSKA OBRTNIČKA KOMORA
CROATIAN CHAMBER OF TRADES AND CRAFTS



Hrvatska obrtnička komora
OBRTNIČKA KOMORA ZAGREB

**ZAGREB CHAMBER OF TRADES
AND CRAFTS**



Tekstilpromet



Coca-Cola
**Hellenic
Bottling
Company**

ŠAFRAN
VINARIJA





Appendix

SYMPOSIUM PROGRAM



Textile Science & Economy 2020.

13th International Scientific-Professional Symposium



VIDEOCONFERENCE



CHINESE-CROATIAN FORUM: Innovation, Design and Digitalization in the Textile and Leather Sector

September 18, 2020
University of Zagreb Faculty of Textile Technology (FTT)

VIRTUAL ROOM A – Invited Lectures

Time (UTC +2)	Agenda	
08:30 - 09:00	Registration for Invited Participant and System Testing	
09:00 - 10:00	Opening the Symposium and Welcome Speeches: <ol style="list-style-type: none"> 1. Dean of the University of Zagreb Faculty of Textile Technology Professor Gordana Pavlović, PhD. 2. President of the Organizing Committee of TSE 2020; Professor Slavenka Petrak, PhD. 3. President of the Committee for Innovation and Technology Transfer, University of Zagreb Professor Tomislav Josip Mlinarić, PhD. 4. Head of the Office for Management and Improvement of Scientific Research Activities at Ministry of Science and Education Hrvoje Meštrić, 5. Founding Member of BASTE - Balkan Society of Textile Engineers Professor Savvas Vassiliadis, PhD. 6. State Secretary Mario AntoniĆ, Republic of Croatia Ministry of Economy and Sustainable Development 7. Rector of the University of Zagreb Professor Damir Boras, PhD. 	
10:00 - 10:30	Gordana Pavlović, Dean of the FTT - Presentation of the University of Zagreb Faculty of Textile Technology	
Invited Lectures		
10:30 - 11:00	Xungai, WANG	Body Odour and Smell Related Properties of Different Fibres and Fiber Blends
11:00 - 11:30	Henry Yi, LI	Facemasks: Wear or Not Wear - Sciences and Facts
11:30 - 11:50	Krešimir, JURAK	Entering the world's biggest market and working with China, the world's manufacturing superpower of the 21 st century

11:50 - 12:10	Tomislav Josip, MLINARIĆ	Innovation Potential of the University of Zagreb in the function of Economic Development of the Republic of Croatia
12:10 – 12:20	BREAK: Virtual Exhibitions of Students Art Work – 2nd Year of Graduate Studies Textile and Fashion Design, Supervisor: Koraljka Kovač Dugandžić	
12:20 - 12:40	Tomislav, KRIŠTOF	Digital Apocalypse and How to Cope
12:40 - 13:00	Davor, SABOLIĆ	Material Development with Respect to Sustainable Growth
13:00 - 13:20	Neven, MARKOVIĆ	Commercialization of Innovation
13:20 – 13:40	BREAK: Short History of University of Zagreb – promotional video	
13:40 - 14:10	Edit, CSANÁK	131 Days in China: Design & Methods
14:10 - 14:30	Tomislav, PRIBANIĆ	Principles of Active Illumination 3D Reconstruction Systems - Application Examples
14:30 - 14:50	Ghadi, ALI	Innovations and Their Commercialization in Entrepreneurship: Innovation Leads to Entrepreneurship
14:50 – 15:00	BREAK: Calligraphy Virtual Workshop and Guzeng music - Confucius Institute Zagreb	
15:00 - 15:30	Uwe, REISCHL	Changes in Fabric Elasticity in Response to Sterilization with Ozone Gas
15:30 - 15:50	Gordan, SMUĐ	Trends and Challenges in Digitalization of Fashion Industry
15:50 - 16:10	Sead, ARSLANAGIĆ	Recycling of Textile Waste Using The Example Of Feasibility Study For Construction of Plant For Recycling (Tptw -Technological Postindustrial Textile Waste)
16:10 - 16:30	Martinia Ira, GLOGAR	Digital Textile Printing - Innovative Directions for Future Development
16:30 – 16:40	BREAK: PROJECT CHINA – Traditional Chinese Theater and Peking Opera as Inspiration for Theater or Film Costume Design – Costume portfolio of 2nd year graduate students of Costume design, supervisor: Ivana Bakal	
16:40	Closing the Symposium	

VIRTUAL ROOM B

Presentation of Selected Scientific Projects on University of Zagreb Faculty of Textile Technology

Presentation of Croatian Companies from Textile and Leather Sector

Time (UTC +2)	Agenda	
 Selected Scientific Projects on FTE		
10:30 - 10:40	Dubravko, ROGALE	Development and thermal properties of intelligent clothing (IP-2018-01-6363)
10:40 - 10:50	Zenun, SKENDERI	Comfort and antimicrobial properties of textiles and footwear (IP-2016-06-5278)
10:50 - 11:00	Budimir, MIJOVIĆ	Custom Tailored Fibrous Scaffold Prototype for Tissue Cells Culture via Combined Electrospinning (IP-2016-06-6878)

11:10 – 12:10	Presentation of Croatian Companies from Textile and Leather Sector
Čateks d.d.	
Odjeća d.o.o.	
Tekstilpromet d.d.	
LECTRA DEUTSCHLAND GMBH	
VARTEKS d. d.	
Zlatna igla - Siscia d.o.o.	
MOIRA d.o.o.	
GRAFKO-CASPAR d.o.o.	
Miret d.o.o.	
VIVIANI d.o.o.	
GALKO d.o.o.	
12:10 – 13:00	Presentation TTF Alumni - Successful Young Entrepreneurs
ANIMA M, by Mirna Posavčević	
Matija Čop fashion studio, London, UK	
Staša design, by Staša Dobljanović Rendel, London, UK	
Yelena H., by Jelena Holec	
Adriana Rajčić Design	
Katarina Mamić Design	
Schapé, Lejla Dizdarević Brković	
Irena Vucinic Jewelry	
DuoD Design, Dijana Žagorac	
13:00 – 13:15	<p>Virtual Exhibition of Students Art Work – 2nd year of undergraduate studies Textile and Fashion Design, Supervisor: Helena Schultheis Edgeler</p> <p>Movie Presentations of Graduate Papers and Fashion Collections – University of Zagreb Faculty of Textile Technology</p>

VIRTUAL ROOM C

Presentation of Doctoral Study Textile Science and Technology, University of Zagreb Faculty of Textile Technology

Presentations of Scientific Research of Ph D Students

Time (UTC +2)	Doctoral Study Textile Science and Technology, University Zagreb Faculty of Textile Technology	
12.30 - 12:40	Movie about Doctoral Study Textile Science and Technology, University of Zagreb, FTT	
12:40 - 12:50	Opening the PhD section - Welcome Speech	
Time (UTC +2)	Ph. D. Students - University of Zagreb Faculty of Textile Technology	
B_Novel Materials: Biomaterials, Nanomaterials And Smart Materials		
12:50 - 13:00	Zorana, KOVACEVIĆ; Sandra, BISCHOF & Mizi, FAN	Nanobiocomposites Reinforced with Spanish Broom (Spartium Junceum L.) Fibres
13.00 - 13:10	Lela, MARTINAGA; Sara, ČAČKO; Stella, HAMILTON; Ana, VRSALOVIĆ PRESEČKI & Iva, REZIĆ	Environmentally Acceptable Synthesis of Nanoparticles for Their Potential Use as Textile Coatings
K_Anthropometric body measurements – modern measurement systems and applications		
13:10 - 13:20	David, BOJANIĆ; Kristijan, BARTOL; Tomislav, PETKOVIĆ & Tomislav, PRIBANIĆ	A Review of Rigid 3D Registration Methods (University of Zagreb Faculty of Electrical Engineering and Computing)
13.20 - 13:30	Maja, MAHNIĆ NAGLIĆ & Slavenka, PETRAK	Development of a Female Body Types Classification Method
13:30 - 13:40	Marija, NAKIĆ & Slavica, BOGOVIĆ	Designing of Functional Garment Item for People with Disabilities
H_Thermophysiological properties and comfort of textiles, clothing and footwear		
13.40 - 13:50	Nikolina, JUKL; Snjezana, FIRŠT ROGALE & Dubravko ROGALE	Thermal Properties of The Protective Vest Tested on a Thermal Manikin in Static Mode
13:50 – 14:00	BREAK: Lacemaking in Croatia – cultural heritage promotional movie	
E_Medical and protective textiles, clothing and footwear		
14.00 - 14:10	Franška, ŽUVELA BOŠNJAK; Sandra, FLINČEC GRGAC & Suzana, MIHANOVIĆ	Application of Microscale Combustion Calorimeter to Characterize Protective Properties of Bovine Leather
G_Analysis and methods of measurement in textiles, clothing and footwear		
14:10 - 14:20	Katia, GRGIĆ & Tanja, PUŠIĆ	Adsorption of Cetylpyridinium Chloride on Standard Polyester Fabric in The Electrokinetic Analyzer
14:20 - 14:30	Rajna, MALINAR & Sandra, FLINČEC GRGAC	Textile Dust Generation from Cotton and Cotton/Polyester Blend Fabrics
14:30 - 14:40	Kristina, ŠIMIĆ; Ivo, SOLJAČIĆ & Tihana, PETROVIĆ LEŠ	Analysis of Metal Threads in The Historical Croatian Textile from 17th to 20th Century
14:40 - 14:50	Mateo Miguel, KODRIĆ KESOVIA & Željko, PENAVA	Applying Image Analysis for Measuring The Density of Historical Textiles
F_Advanced Processes Of Finishing, Care, Dyeing And Printing Of Textiles And Leather		

14:50 - 15:00	Ksenija, VIŠIĆ & Tanja, PUŠIĆ	The Influence Physico-Chemical Properties of Anti-Redeposition Agents on The Zeta Potential of Washed Cotton Fabrics
15:00 – 15:10	BREAK: Movie presentation of University of Lodz	
Time (UTC +2)	Ph. D. Students - Technical University of Lodz, Faculty of Material Technologies and Textile Design	
F_Advanced Processes Of Finishing, Care, Dyeing And Printing Of Textiles And Leather		
15:10 - 15:20	Anna, BEDNAROWICZ & Zbigniew, DRACZYŃSKI	Modification of Cotton Fabric with Cross-Linked and Grafted Gelatine
15:20 - 15:30	Nina, TARZYŃSKA & Zbigniew, DRACZYŃSKI	Impact of The Aging Process on Sodium Alginate Solutions With The Addition of Low Molecular Weight Ionic Compounds
15:30 - 15:40	Dominik, SIKORSKI & Zbigniew, DRACZYŃSKI	Assessment of The Degree of Attachment of Acid Groups to Chitosan Fibers
15:40 – 15:50	Session closing	