

University of Zagreb  
Faculty of Textile Technology

Textile Science and Economy  
French - Croatian Forum

2019

# BOOK OF PROCEEDINGS

12<sup>th</sup> International Scientific-Professional Symposium Textile Science & Economy



January 23<sup>rd</sup> to 24<sup>th</sup>, 2019  
Zagreb, Croatia

Editor - in - Chief:  
Ivan Novak

Edited by:  
Ivana Schwarz  
Ivana Špelić  
Emilija Zdraveva



**Organized by:**

**University of Zagreb**  
**Faculty of Textile Technology**  
Zagreb, Croatia

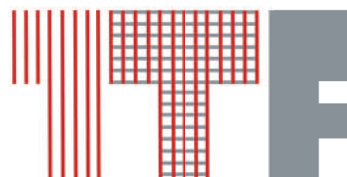

**Partners:**



**Under the Auspices of:**



PRESIDENT OF CROATIA  
KOLINDA GRABAR - KITAROVIC



Sponsors & Donators:

**TEXTILE  
& REVIEW  
LEATHER**

  
**Zagreb**  
CROATIA

  
**BERNARDA**  
KREVETI I MADRACI

**VARTEK&**

  
**KAP-KO**

  
**SPLENDOR  
TEKSTIL**

  
**KRAŠ**  
1911

  
**Odjeća**



**Coca-Cola HBC**  
**Hrvatska**

  
**DOBRO**

  
**BELINA**

  
**CITROËN**

  
**Anton Paar**

  
**regeneracija**

12<sup>th</sup> International Scientific - Professional Symposium  
Textile Science & Economy  
**French - Croatian Forum 2019**  
January 23<sup>rd</sup> to 24<sup>th</sup>, 2019, Zagreb, Croatia



**Book of Proceedings of the  
12<sup>th</sup> International  
Scientific - Professional Symposium  
Textile Science & Economy (TZG)  
French - Croatian Forum 2019**

ISSN 2584 - 6450





**Publisher:** University of Zagreb, Faculty of Textile Technology, Prilaz Baruna Filipovića 28a, 10000 Zagreb, Croatia

**Editor in Chief:** Ivan Novak

**Editors:** Ivana Schwarz, Emilija Zdraveva & Ivana Špelić

**Editorial board:** Vladan Končar, Ana Marija Grancarić, Alica Grilec, Bosiljka Šaravanja, Ružica Brunšek, Lea Botteri, Davor Jokić

**Logo of TZG created by:** Martinia Ira Glogar

**Cover & graphic design by:** Ivana Špelić

### Editor's Note

All the papers presented in this publication have been reviewed and approved by International Review Committee. However, the editor and the TZG 2019 organiser are not responsible for the contents and the opinions expressed in the papers presented. All the rights belong to the authors, meaning further publication conditions should be agreed upon with the authors themselves. All mistakes in the manuscript could not be changed nor the English checked. The readers are kindly asked to excuse any eventual mistake, which may have arisen from the above-mentioned causes. After the publication of the Book of Proceedings of the 12<sup>th</sup> International Scientific - Professional Symposium, Textile Science & Economy: French - Croatian Forum TZG 2019, the authors and other persons/ institutions wishing to use the papers published here, are kindly requested to explicitly identify the work published in the Book of Proceedings, including the ISSN number above and the page numbers concerned.

Publishers contact address:

Organizing Committee TZG 2019  
University of Zagreb  
Faculty of Textile Technology  
Prilaz baruna Filipovića 28a  
10000, Zagreb, Croatia  
e - mail: [tzg2019@ttf.hr](mailto:tzg2019@ttf.hr)

### **ORGANISING COMMITTEE**

PRESIDENT – Ivan Novak FTT (Croatia)  
Vladan Končar ENSAIT – GEMTEX (France)  
Ivana Schwarz FTT (Croatia)  
Emilija Zdraveva FTT (Croatia)  
Alica Grilec FTT (Croatia)  
Bosiljka Šaravanja FTT (Croatia)  
Ivana Špelić FTT (Croatia)  
Lea Botteri FTT (Croatia)  
Ružica Brunšek FTT (Croatia)  
Davor Jokić FTT (Croatia)  
Darko Ujević FTT (Croatia)  
François Dassonville ENSAIT – GEMTEX (France)  
Frane Šesnić ZICER (Croatia)

### **SCIENTIFIC PROGRAMME COMMITTEE**

CO-PRESIDENT – Vladan Končar ENSAIT – GEMTEX (France)  
CO-PRESIDENT – Ana Marija Grancarić FTT (Croatia)  
Dominique Adolphe ENSISA (France)  
Pascal Bruniaux ENSAIT – GEMTEX (France)  
François Boussu ENSAIT – GEMTEX (France)  
Damien Soulat ENSAIT – GEMTEX (France)  
Xavier Legrand ENSAIT – GEMTEX (France)  
Cedric Cochrane ENSAIT – GEMTEX (France)  
Xuyuan Tao ENSAIT – GEMTEX (France)  
Sebastien Thomassey ENSAIT – GEMTEX (France)  
Charafeddine Jama ENSCL (France)  
Paul Kiekens UGENT (Belgium)  
Omar Cherkaoui ESITH (Morocco)  
Saber ben Abdessalam ENIM (Tunisia)  
Faten Debbabi ENIM (Tunisia)  
Aura Mihai TUIASI (Romania)  
Emilia Visileanu INCDTP (Romania)  
Rene Rossi EMPA (Switzerland)  
Gordana Pavlović FTT (Croatia)  
Snježana Firšt Rogale FTT (Croatia)  
Ivana Salopek Čubrić FTT (Croatia)  
Maja Somogyi Škoc FTT (Croatia)  
Helena Schultheis Edgeler FTT (Croatia)



**COMMITTEE FOR COOPERATION  
WITH ECONOMY AND MARKETING**

Bosiljka Šaravanja FTT (Croatia)  
Ivana Špelić FTT (Croatia)  
Ivana Rajković Pavlič ZICER (Croatia)  
Siniša Zver IVANČICA (Croatia)  
Goran Arambašić KELTEKS (Croatia)  
Milan Lušić VARTEKS (Croatia)  
Ivana Kovač KAP-KO (Croatia)  
Jasminka Korotaj ODJECA (Croatia)  
Branko Glasnović JACQUARD (Croatia)  
Božidar Ledinko GALKO (Croatia)  
Suzana Perčić SPLENDOR (Croatia)  
Jagoda Divić HGK (Croatia)  
Neila Noura Gongi MFPCOL (Tunisia)

**INTERNATIONAL REVIEW COMMITTEE OF THE  
12<sup>TH</sup> INTERNATIONAL SCIENTIFIC - PROFESSIONAL SYMPOSIUM TEXTILE SCIENCE & ECONOMY  
FRENCH - CROATIAN FORUM 2019**

Saber ben ABDESSALEM (TN)  
Matejka BIZJAK (SLO)  
Slavica BOGOVIĆ (HR)  
Blaženka BRLOBAŠIĆ ŠAJATOVIĆ (HR)  
Omar CHERKAOUI (MA)  
Cedric COCHRANE (FR)  
Faten DEBBABI (TN)  
Andrej DEMŠAR (SLO)  
Krstje DIMITROVSKI (SLO)  
Lidija FRAS ZEMLJIĆ (SLO)  
Emi GOVORČIN BAJSIĆ (HR)  
Ana Marija GRANCARIĆ (HR)  
Alica GRILEC (HR)  
Charafeddine JAMA (FR)  
Paulina JAZVIĆ (HR)  
Dragana KOPITAR (HR)  
Kiril LISICKOV (MK)  
Budimir MIJOVIĆ (HR)  
Žarko PAIĆ (HR)  
Željko PENAVA (HR)  
Slavenka PETRAK (HR)  
Vesna Marija POTOČIĆ MATKOVIĆ (HR)  
Tatjana RIJAVEC (SLO)  
Rene ROSSI (CH)  
Ivana SALOPEK ČUBRIĆ (HR)  
Pablo Jimenez SCHLEGL (ES)  
Helena SCHULTHEIS EDGELER (HR)  
Majda SFILIGOJ SMOLE (SLO)  
Zenun SKENDERI (HR)  
Maja SOMOGYI ŠKOC (HR)  
Damien SOULAT (FR)  
Irena ŠABARIĆ (HR)  
Olivera ŠAUPERL (SLO)  
Željko ŠOMOĐI (HR)  
Ivana ŠPELIĆ (HR)  
Sonja ŠTERMAN (SLO)  
Xuyuan TAO (FR)  
Emilia VISILEANU (RO)  
Tonči VLADISLAVIĆ (HR)  
Julija VOLMAJER VALH (SLO)  
Tonghua ZHANG (AU)





## Preface

The 12<sup>th</sup> International Scientific - Professional Conference Textile Science & Economy French - Croatian Forum took place in Zagreb, Croatia between the 23<sup>rd</sup> and 24<sup>th</sup> January 2019. The University of Zagreb, Faculty of Textile Technology organized the Conference in cooperation with our renowned partners: the Zagreb Innovation Centre, ENSAIT (Ecole Nationale Supérieure des Arts et Industries Textiles) and GEMTEX Textile Research Laboratory.

The 12<sup>th</sup> International Scientific - Professional Conference Textile Science & Economy (TZG) 2019 was held with our respected French colleagues in order to present all of the necessity and potentials of both scientific and economical collaboration. This year's aim of Conference was to bring together various respected scientists and leading industry experts from various areas of textile application, apparel, footwear, leather and accessories, in order to exchange their valuable knowledge and experience, establishing cooperation and accomplishing integration. The goal was to provide unified networking platform among Croatian, French and other international scientist and industry representatives.

Issue of a Book of Abstracts and Book of Proceedings accompanies the Conference. We express great satisfaction with the response of renowned scientists and business experts from Croatia, France and other countries, especially to, distinguish Professor Vladan Končar, Professor Dominique Adolphe and Professor Paul Kiekens and to Mr Jacek Mlynarek. Our sincere thanks also goes to all institutions, business entities, our partners, lecturers, patrons, sponsors, authors of papers, reviewers, exhibitors, organizing, scientific and editorial staff, as well as all other associates who have contributed to this Textile Science & Economy Conference and the publication of this Book of Proceedings. We hope that this French - Croatian Forum will lead to better cooperation between the researchers and business persons of the two countries, as well as in strengthening the sector's competitiveness in the European market.

My special thanks goes to all of my young associates that brought this conference to this level, as well as to associations that have accepted to be the patrons of the conference, proving it to be necessary, justified and useful. My sincere gratitude also goes to all other individuals and institutions that have helped organising the 12<sup>th</sup> TZG 2019 French - Croatian Forum. Finally, I wish to thank all the authors submitting papers, the reviewers who helped by improving the quality of the papers and offering their sincere advices, and to scientific committee who supervised the creation of this Book of Proceedings. All of them enabled the promotion of knowledge, showed great discipline and patience while making corrections and improvements.

Assoc. Prof. Ivan Novak, Ph. D.

A handwritten signature in blue ink, appearing to be 'Ivan Novak', written over a faint watermark of the TZG logo.

# List of Authors

The logo consists of the letters 'TZG' in a bold, dark grey, sans-serif font. The letter 'G' is stylized with a red square cutout in its upper right quadrant. The logo is positioned on the right side of the page, partially overlapping a large, stylized 'Z' shape that is outlined in red and black. The background features a collage of light blue and white geometric shapes, including triangles and polygons, some with soft shadows, creating a layered, 3D effect.



<b>A</b>	DIMITROVSKI Krste	JOVANOVIĆ Tea
ALI Arshad	DOLEŽAL Ksenija	JUGOV Nikola
<b>B</b>	<b>F</b>	<b>K</b>
BARETIĆ Nikolija	FETTOUCHE Souad	KARIN Franka
BEHARY Nemeshwaree	FIRŠT ROGALE Snježana	KAZIUR Patrycja
BIZJAK Matejka	<b>G</b>	KOPITAR Dragana
BOUKHRISS Aicha	GAŠPARAC Kristina	KOSALEC Ivan
BRLOBAŠIĆ ŠAJATOVIĆ Blaženka	GLOGAR Martinia Ira	KOVAČEVIĆ Stana
BRNADA Snježana	GMOUH Said	KOVAČEVIĆ Zorana
BRUNIAUX Pascal	GOVORČIN BAJSIĆ Emi	<b>L</b>
BRUNŠEK Ružica	<b>H</b>	LALIĆ Karla
BUDIN Rajka	HASSANDOUST Sahar	<b>LJ</b>
<b>C</b>	HOLJEVAC GRGURIĆ Tamara	LJOLJIĆ BILIĆ Vanja
CHERKAOUI Omar	HRŽENJAK Renata	<b>M</b>
<b>Č</b>	<b>I</b>	MARIĆ Ana
ČUBRIĆ Goran	IYER Sweta	MASLANKA Paulina
ČUPIĆ Marina	<b>J</b>	MIHELIĆ - BOGDANIĆ Alka
<b>D</b>	JAKUŠ Sanja	MIJOVIĆ Budimir
DEKARIS Iva	JAKOVLJEVIĆ Suzana	MILOŠ Lozo



MOSLEH Sarah	ROGALE Dubravko	<b>U</b>
<b>N</b>	<b>S</b>	UJČIĆ Massimo
NIERSTRASZ Vincent	SALOPEK ČUBRIĆ Ivana	UJEVIĆ Darko
<b>O</b>	SCHWARZ Ivana	<b>V</b>
OJDENIĆ ĐEREK Dora	SOMOGYI ŠKOC Maja	VALEK Irena
<b>P</b>	<b>Š</b>	VIDAKOVIĆ Petar
PAVKO-ČUDEN Alenka	ŠABARIĆ Irena	VILMAN PROJE Jana
PAVLOVIĆ Željka	ŠOMOĐI Željko	VRLJIČAK Zlatko
PETROV Antonija	ŠPELIĆ Ivana	<b>Y</b>
PINTARIĆ Lela	ŠTEMBERGER Marjanca	YANG Yunchu
POKROVAC Ivan	<b>T</b>	YU Bin
POTOČIĆ MATKOVIĆ Vesna Marija	TALBALAGHI Asghar	<b>Z</b>
PUŠIĆ Tanja	TAHIRI Mohamed	ZDRAVEVA Emilija
<b>R</b>	TARTARE Guillaume	ZHU Feichao
RADIĆ Zola	TKALEC Marijana	
RANT Darja	TOMIĆ Tena	
REZIĆ Iva	TOMINAC TRCIN Mirna	

# Contents

# ZG





<b>Front matter</b>	
<b>GENERAL INFORMATION &amp; EDITOR'S NOTE</b>	<b>V</b>
<b>ORGANISING COMMITTEE</b>	<b>VI</b>
<b>SCIENTIFIC PROGRAMME COMMITTEE</b>	<b>VI</b>
<b>COMMITTEE FOR COOPERATION WITH ECONOMY AND MARKETING</b>	<b>VII</b>
<b>INTERNATIONAL REVIEW COMMITTEE</b>	<b>VII</b>
<b>Preface</b>	<b>VIII</b>
<b>List of Authors</b>	<b>IX</b>
<b>Table of Contents</b>	<b>XII</b>
<b>Textiles functionalization, finishing, dyeing and printing</b>	
<b><i>Measurement of luminescence intensity on textiles using Luminous bacterial biocatalytic system</i></b>	<b>2</b>
Sweta IYER, Nemeshwaree BEHARY, Vincent NIERSTRASZ	
<b><i>New fluorescent and colorimetric test kit based cellulosic textile for Cyanide detection</i></b>	<b>10</b>
Souad FETTOUCHE, Aicha BOUKHRISS, Mohamed TAHIRI, Omar CHERKAOUI, Said GMOUH	
<b><i>Investigating of silica-cinnamon hybrid materials – preparation and characterization for medical application</i></b>	<b>19</b>
Maja SOMOGYI ŠKOC, Iva REZIĆ, Kristina GAŠPARAC	
<b><i>Interaction of Color and Surface in Decorative Textile Product Design</i></b>	<b>29</b>
Marijana TKALEC, Martinia Ira GLOGAR, Ana MARIĆ	
<b>Clothing technology and engineering</b>	
<b><i>Createing 3D Garment Pattern from Adaptive Digital Modelling of Human Spine for Persons with Spinal Disability</i></b>	<b>43</b>
Sarah MOSLEH, Pascal BRUNIAUX, Guillaume TARTARE	
<b><i>Innovative Ideas by Students at the Textile Technology Faculty in the field of smart clothing</i></b>	<b>54</b>
Snježana FIRŠT ROGALE, Dubravko ROGALE	
<b><i>Investigations of body proportions of students football players in Croatia and China</i></b>	<b>64</b>
Darko UJEVIĆ, Blaženka BRLOBAŠIĆ ŠAJATOVIĆ, Ksenija DOLEŽAL, Yu BIN, YUNCHU YANG, FEICHAO ZHU	
<b><i>Performance of Diving Suits from the Aspect of Thermal Comfort</i></b>	<b>69</b>
Vesna Marija POTOČIĆ MATKOVIĆ, Ivana SALOPEK ČUBRIĆ, Goran ČUBRIĆ	
<b><i>Possible robot application in grasping the textile material with a vacuum griper</i></b>	<b>79</b>
Goran ČUBRIĆ, Marina ČUPIĆ	
<b><i>Construction of a dress for school aged girls</i></b>	<b>86</b>
Zola RADIĆ, Renata HRŽENJAK	
<b>Fibers, yarns, fabrics, technical textiles and nonwovens</b>	
<b><i>Analysis of Advanced Textile Material for Automotive Application</i></b>	<b>99</b>
Ivana SCHWARZ, Ružica BRUNŠEK, Zorana KOVAČEVIĆ, Stana KOVAČEVIĆ	
<b><i>Difficulties in table linens production process</i></b>	<b>108</b>
Snježana BRNADA, Ivana SCHWARZ, Tanja PUŠIĆ, Stana KOVAČEVIĆ, Irena VALEK	
<b><i>Equivalent average diameter of pores - definition and determination</i></b>	<b>115</b>
Krste DIMITROVSKI	
<b><i>An Introductory Computational Deformational Model of Body - Sock Interaction</i></b>	<b>123</b>
Željko ŠOMOĐI, Željka PAVLOVIĆ, Emilija ZDRAVEVA, Zlatko VRLJIČAK	



<b><i>The compressibility of fine women's hosiery with elastane</i></b>	<b>131</b>
Željka PAVLOVIĆ, Tea JOVANOVIĆ, Lozo MILOŠ, Zlatko VRLJIČAK	
<b><i>The effect of the filler and layers on the properties of electrospun antibiotic/ fibroin scaffolds</i></b>	<b>143</b>
Emilija ZDRAVEVA, Budimir MIJOVIĆ, Tamara HOLJEVAC GRGURIĆ, Emi GOVORČIN BAJSIĆ, Iva DEKARIS, Mirna TOMINAC TRCIN, Massimo UJČIĆ, Patrycja KAZIUR, Paulina MASLANKA	
<b><i>Compressional behaviour of nonwoven fabrics</i></b>	<b>151</b>
Petar VIDAKOVIĆ, Dragana KOPITAR	
<b><i>Mediterranean wild silk – the properties of fibers</i></b>	<b>166</b>
Nikola JUGOV, Ružica BRUNŠEK	
<b><i>The tensile properties of yarns tied to the scout knots</i></b>	<b>179</b>
Antonija PETROV, Ivana SALOPEK ČUBRIĆ	
<b><i>Exploring the Properties of Yarns for the Collection of Designer Chairs</i></b>	<b>187</b>
Dora OJDENIĆ ĐEREK, Ivana SALOPEK ČUBRIĆ	
<b><i>Multiple faces of knitting in past and modern times</i></b>	<b>196</b>
Alenka PAVKO-ČUDEN	
<b><i>Self-foldable knitted structures</i></b>	<b>211</b>
Darja RANT, Alenka PAVKO-ČUDEN	
<b>Environmental aspects &amp; energy management</b>	
<b><i>Antimicrobial metal/ metal oxide nanoparticles in textile industry and their impact on the environment</i></b>	<b>230</b>
Iva REZIĆ, Maja SOMOGYI ŠKOC, Lela PINTARIĆ, Ivan KOSALEC, Vanja LJOLJIĆ BILIĆ, Ivan POKROVAC, Tena TOMIĆ, Karla LALIĆ, Suzana JAKOVLJEVIĆ	
<b><i>Evaluation of a promising botanical repellent on horses and perspectives as strategy to lower the risk of equine WNV for lowering the Pediculosis risk at schools in Iran</i></b>	<b>239</b>
Asghar TALBALAGHI, Sahar HASSANDOUST, Arshad ALI	
<b><i>Energy savings in shoe sole production process</i></b>	<b>245</b>
Ivana ŠPELIĆ, Alka MIHELIĆ - BOGDANIĆ, Rajka BUDIN	
<b>Design, fashion trends &amp; marketing</b>	
<b><i>Implementation of model for designing affiliated clothing with local identity</i></b>	<b>256</b>
Jana VILMAN PROJE, Matejka BIZJAK	
<b><i>Knitwear and style</i></b>	<b>265</b>
Marjanca ŠTEMBERGER, Alenka PAVKO-ČUDEN	
<b><i>The design of customized work clothes for kindergarten teacher</i></b>	<b>281</b>
Sanja JAKUŠ, Irena ŠABARIĆ, Franka KARIN	
<b><i>Modelling a collection of women dresses inspired by the anomalies in human behaviour</i></b>	<b>294</b>
Nikolija BARETIĆ, Ksenija DOLEŽAL	

**Textiles functionalization, finishing,  
dyeing & printing**

**TZG**



# MEASUREMENT OF LUMINESCENCE INTENSITY ON TEXTILES USING LUMINOUS BACTERIAL BIOCATALYTIC SYSTEM

**Sweta IYER<sup>1, 2\*</sup>, Nemeshwaree BEHARY<sup>1, 2</sup>, Vincent NIERSTRASZ<sup>3</sup>**

<sup>1</sup>ENSAIT-GEMTEX, F-59100, Roubaix, France, \*email: sweta.iyer@hb.se

<sup>2</sup>Université Lille Nord de France, F-59000, Lille, France

<sup>3</sup>Textile Materials Technology, Department of Textile Technology, Faculty of Textiles, Engineering and Business, University of Borås, SE-50190, Borås, Sweden

---

## ABSTRACT

*Nature is the most exquisite thing around us with the existence of living organisms exhibiting different phenomena such as water repellency, touch sensitive plant and chameleon skin. Some of these phenomena inspired scientists to explore and design smart fabrics biomimicking the behaviour or pattern in living organisms. Bioluminescence is one such phenomenon where-in different living organisms such as firefly, jelly fish and crustaceans have the ability to impart visible light of specific wavelength, by enzyme catalysed reactions. Existence and study of such light emitting living organisms have been carried out, and harnessing these reactions has already transformed significant areas of medical field and clinical diagnosis, but research work on transforming this into living light is limited. In the present study, luminous bacterial system was investigated to assess and detect the bioluminescence behaviour onto the textile material. In the Luminous bacterial system, in vivo biochemical mechanism involves two different enzymes as well as different substrate components. Emission of light due to in vivo luminous bacterial reaction mechanism is seen in visible region.*

*For in vitro reaction mechanism study, physical adsorption technique was used to graft both enzymes on plasma activated PET nonwoven textile and when substrates were introduced manually during the analysis, the biochemical reaction leading to light production occurred. A Luminometer equipment was used to determine the light intensity in terms of Relative light units (RLU). The measurement results were obtained for nonwoven plasma treated PET with enzyme and substrate addition at different concentration and RLU value was obtained. The analysis data revealed that light intensity in RLU could be recorded by introducing both the enzymes and substrates on textile material, however intensive research is required in order to observe emitted light through the naked eye. The research study will help to attain new approaches for obtaining luminescent textiles using biobased resources.*

## KEYWORDS

*Biomimicking, Luminous bacterial, Luminescent textile*

---

## INTRODUCTION

Nature has designed a few bio-based molecules which are responsible for bioluminescence in some living species. There are diverse living organisms present in sea as well as land environment such as fireflies, jellyfish, fungi and bacteria that produce light via enzymatically catalysed chemical reactions. Many research works have been carried to study bioluminescence, by considering the morphology, physiology and chemistry involved in light producing organisms. The molecules responsible for bioluminescence in jelly fish was discovered by Nobel Laureate 'Osamu Shimomura' and different aspects of bioluminescence chemistry have been reviewed [1]. The light emitting

phenomenon can be seen in luminous organisms due to two principal components luciferin (the substrate) and luciferase (the enzyme). 'Firefly' is one such organism of luciferin-luciferase reaction system, wherein presence of specific enzyme (firefly luciferase) oxidizes corresponding substrate (generically known as luciferin) in presence of oxygen and other co-factors such as ATP and magnesium ions to emit light (Fig. 1).

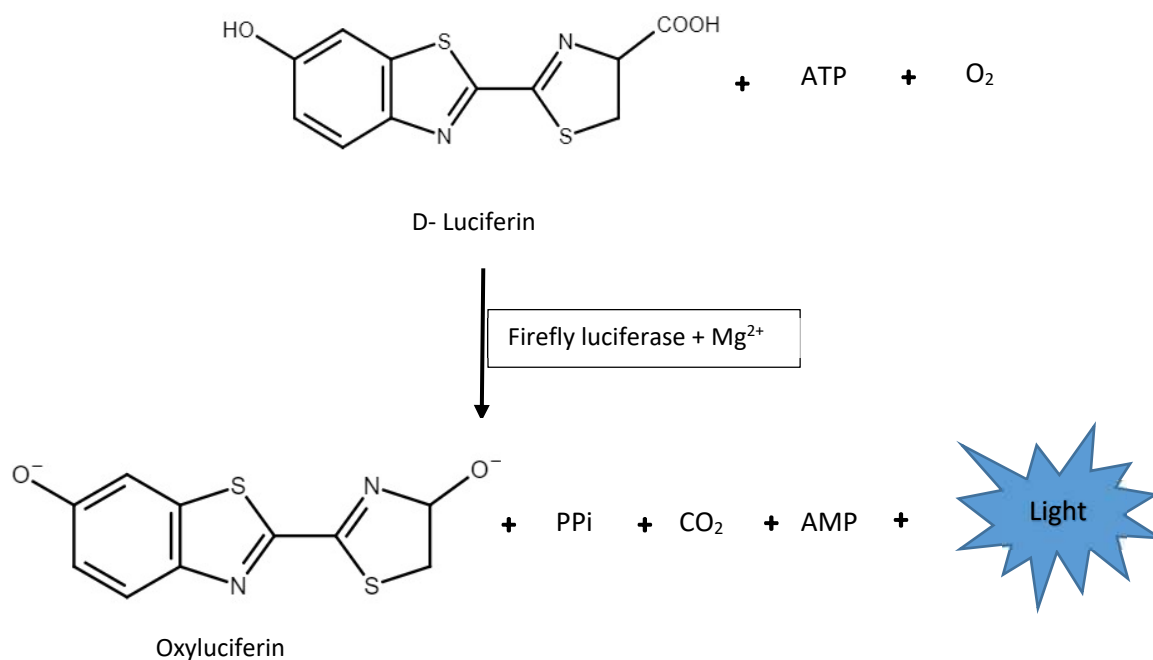

Figure 1: Reaction mechanism of Firefly (Luciferin-luciferase)

Depending upon the ecological presence and physiology behaviour of different luminous organisms, the excitation mechanism and energetics of bioluminescence vary. Hence, there exist a broad color spectrum of bioluminescent signal from blue, green and red shifted emissions ranging from 450 to 580 nm [2]. Bioluminescence has wide application in the field of bioresearch. Although bioluminescence reaction systems have been extensively used as environmental biosensors for screening and evaluating the biological effects of toxicity [3], bioluminescence assay to determine low level of microbial contamination on textile material [4], luminescence in yeast containing bacterial luciferase for screening or detection of antifungal compounds [5] but until now the biobased reaction system has not been studied to produce bioluminescent textiles.

Applications of luminescent textiles for architecture, safety, sportswear and apparel [6] are wide but there are also other applications, which exist such as wearable sensors and biosensors [7] [8][9]. Hence, it is of great interest to create different application based on the bioluminescence system existing in nature. In the current paper, the application approach will allow developing the concept

regarding the mechanisms of interaction of substrates with the light emitting proteins or enzymes on the surface of textile material. In particular, the in vivo luminous bacterial system involves biochemical reaction consisting of specific enzyme and substrate components [10]. The in vitro reaction studied involved physical adsorption of luciferase enzyme on textile support and substrates introduced manually to count the photons of light in RLU using luminometer. Thus, the present work focuses on designing of biobased luminescent textile.

## EXPERIMENTAL

### Materials and Methods

The enzymes and substrates used in the experiments were purchased commercially. The measurements were performed using a Luminometer MicrolumatPlus LB 96V (France). The equipment detector consist of ultra fast single photon counter system having spectral sensitivity range for wavelength of 380 – 630 nm. The light emission was measured as Relative light units (RLU).

#### *Luminometer equipment*

A luminometer equipment is used to measure the light produced due the chemical reaction occurring and can be measured in the form of Relative light units (RLU). Generally, it is used to measure chemical marker ATP, which is a compound found in all types of plant, wherein the amount of light is proportional to the amount of ATP present [11].

#### *Nonwoven PET sample*

A 100 % nonwoven polyester (PET) fabric of density 230 g/m<sup>2</sup>, diameter of 12 μm and thickness of 950 μm was used. The fabric was initially cleaned using Petroleum ether in Soxhlet followed by rinsing and drying of the fabric in ethanol and distilled water subsequently to remove the spinning oil and surface impurities [12].

#### *Plasma treatment of nonwoven PET*

Plasma treatment modifies the polymer matrix using plasma gases. The plasma gases made up of mixture of free radicals, electrons and ions activate the PET fiber surface [13]. Hence, the nonwoven PET was plasma treated for enzyme immobilization experimental study.

A '50 x 50 cm' PET nonwoven fabric was cut into square pieces according to the electrode length of the plasma machine. The plasma treatment was performed using an air atmospheric plasma machine called "Coating Star" manufactured by Ahlbrandt system (Germany). The following machine parameters were kept constant; the electrical power of 1kW, frequency of 26 kHz, speed of the fabric

2m/min, electrode length of 0.5m, and an interelectrode distance of 1.5mm along with treatment power of 45 kJ/m<sup>2</sup>. After plasma treatment, each treated sample was kept in aluminum foil well away from light.

#### *Contact angle and capillarity measurement methods*

The plasma treated samples were characterized using contact angle and capillarity measurements on a tensiometer to quantify the surface treatment modifications. Using the apparatus 3S Balance from GBX Instruments (France) the capillarity weight (g) of the meniscus ( $W_m$ ) of fabric sample at 3 min was measured using Wilhelmy principle method [14]. The water contact angle ( $\theta$ ) at the nonwoven sample surface could be determined from the calculated meniscus weight ( $W_m$ ) using below equation (1), [15].

$$W_m \times g = \gamma L \times \cos\theta \times p \quad (1)$$

As both the ( $\gamma L$ ) surface tension of liquid water in  $\text{mN m}^{-1}$  and ( $p$ ) perimeter of the contacting surfaces in  $\text{mm}$  were known. The increase in surface energy of plasma treated sample can be seen by a reduction in water contact angle. The contact angle of plasma treated PET obtained with value  $0^\circ$  in comparison to the untreated PET fabric with value  $141^\circ$ .

#### *Enzyme immobilization for PET activated surface after plasma treatment*

Immobilization on PET nonwoven textile was carried out using direct sorption/ adsorption technique. A  $1 \times 1 \text{ cm}$  of plasma treated PET nonwoven fabric was cut and placed in a Petri dish with enzyme luciferase and FMN reductase enzyme involved in reaction of luminous bacterial system. The petri dish was stored in a refrigerator at  $4^\circ \text{C}$  for 18 hours. Further, the nonwoven PET was removed from the petri dish and then dried at room temperature. Meanwhile the substrate components of luminous bacterial reaction system were freshly prepared. The immobilized textile sample was introduced in the sample holder of the luminometer equipment and the freshly prepared substrate components were injected manually to determine the intensity of the reaction in the form of Relative light units (RLU) (as seen in Fig. 2).

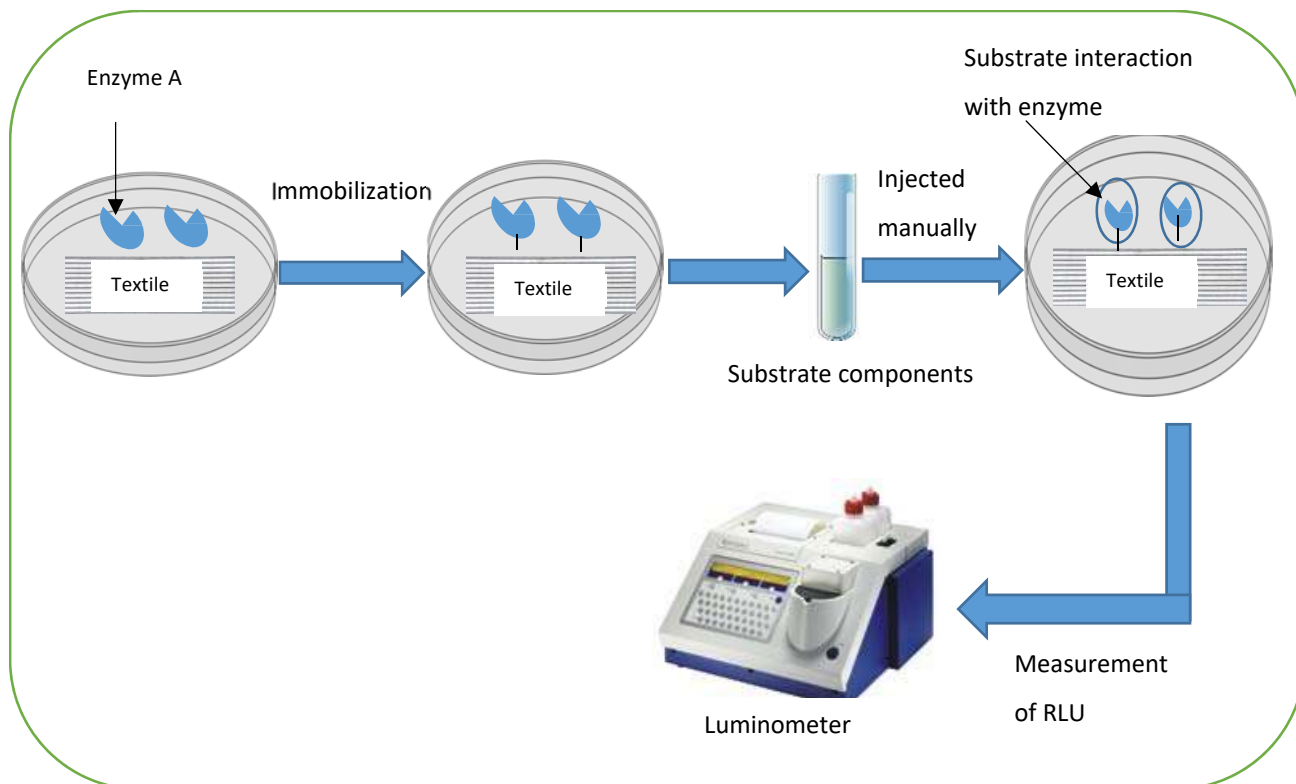

Figure 2. Schematic representation for preparation and flow diagram for luminescence analysis on textiles

## RESULTS AND DISCUSSIONS

### Measurement of reaction mixture using luminometer

At the first stage of analysis, the reaction mixture was studied in the solution form and intensity was measured using luminometer. Different concentration of luciferase enzyme and substrate components were prepared. Optimization of the concentration for enzyme and substrate components provided intensity (RLU) values and maximum intensity was attained at about 9000 RLU. The measurements were repeated and were noted in the time frame of 2 minutes after manually injecting the substrate components required for the reaction to occur. As seen in Figure 3, the RLU value was obtained in the range of 8000 to 9000 for three different measurements.

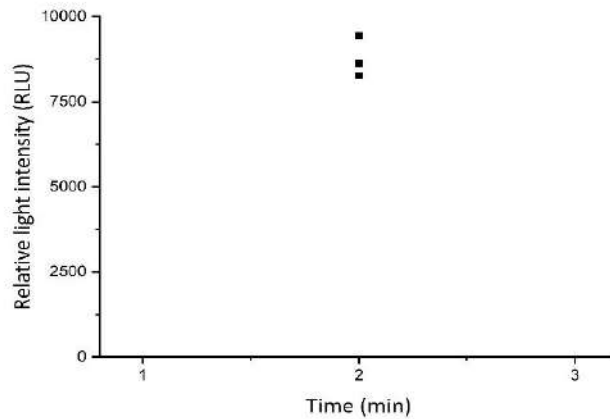

Figure 3. Relative light units (RLU) observed for solution mixture of luminous bacterial system

At the next stage of analysis, the physically adsorbed enzyme immobilized textile was measured for luminescence intensity. Plasma treatment modifies the surface properties by inserting chemical functionalities of free radical onto supporting material allowing textile surface for grafting of enzymes or proteins, enabling easy diffusion[16]. There exist different methodologies to immobilize the enzyme on plasma activated nonwoven such as entrapment and direct sorption, however, in this research work the direct sorption technique has been used to determine the intensity on textiles using luminous bacterial system [13]. The intensity measurement for the immobilized textile in presence of the substrate components provided intensity value of about 500 RLU. The repeated analysis measurement provided the intensity value in the range of 450 – 500 RLU. It was found experimentally that analysis of enzyme treated nonwoven textile using luminometer in presence of luminous bacterial system led to photons of light and the RLU value could be determined as seen in Fig. 4.

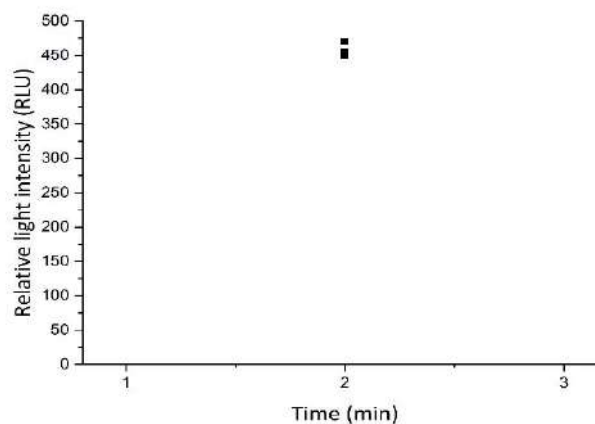

Figure 4. Relative light units (RLU) observed for immobilized textile of luminous bacterial system

The bioluminescence phenomenon occurring in bacterial luciferase exhibit emission of visible light due to chemical reaction at wavelength 470 nm [17]. The luminous bacterial biocatalytic system using luminous bacteria is abundantly been used to develop specific methods of analysis of a variety of metabolites and for determination of enzyme activity; it serves as test device for determining the integral toxicity of different environments. Normally, application of luminous bacteria system have been explored for use of environmental biosensors and bioassays based on reaction system [3] [18]. However, in the current study the luminous bacteria reaction system have been introduced on textile surface and the maximum intensity achieved as relative light units (RLU) is measured and discussed.

## CONCLUSIONS

Hence, the results obtained in this work demonstrated the possibility of fabricating a luminescence textile surface consisting of luminous bacteria reaction system. Fixation of enzymes on textile surface can be achieved further using covalent bonding with chemical reactants and biological protein-protein interaction. The entrapment of enzymes in natural polymer gels such as gelatin and starch improves the enzyme stability and the verification of the possibilities and potential of these method is subject for further evaluation to achieve stable enzymatic system and increase the RLU value on textiles.

## Acknowledgements

This research project is financially aided by European commission, Erasmus Mundus joint Doctorate program with Specific Grant agreement n° 2016-1353/001-001-EMJD under the framework of Sustainable management and Design for Textiles (SMDTex).

## REFERENCES

- [1] O. Shimomura, *Bioluminescence*, Revised. WORLD SCIENTIFIC, 2012.
- [2] S. H. D. Haddock, M. A. Moline, and J. F. Case, "Bioluminescence in the Sea," 2010.
- [3] G. S. Erzinger *et al.*, "Bioluminescence systems in environmental biosensors," *Bioassays Adv. Methods Appl.*, pp. 242–262, 2017.
- [4] B. J. McCarthy, "Bioluminescent assay of microbial contamination on textile materials," *International Biodeterioration and Biodegradation*, vol. 48, no. 1–4. pp. 79–83, 2001.
- [5] R. Szttnner, G. Jansen, D. Y. Thomas, and E. Meighen, "Bright stable luminescent yeast using bacterial luciferase as a sensor," *Biochem. Biophys. Res. Commun.*, vol. 309, no. 1, pp. 66–70, Sep. 2003.
- [6] S. U. Patwary, K. Farhana, and S. Ahmed, "Smart Textiles and Nano-Technology : A General

- Overview Textile Science & Engineering Smart Textiles and Nano-Technology : A General Overview," no. February, 2015.
- [7] E. Tamiya, Y. Inoue, and K. Yamanka, "Mobile / wearable electrochemical biosensors with printable electrodes," pp. 199–200, 2015.
- [8] N. Jürgensen *et al.*, "Solution-Processed Bio-OLEDs with a Vitamin-Derived Riboflavin Tetrabutryrate Emission Layer," *ACS Sustain. Chem. Eng.*, vol. 5, no. 6, pp. 5368–5372, 2017.
- [9] M. Layer-by-layer and N. Technique, "Luminescence-Based Optical Sensors Fabricated by," 2017.
- [10] J. W. Eckstein, J. W. Hastings, and S. Ghisla, "Mechanism of Bacterial Bioluminescence: 4a,5-Dihydroflavin Analogs as Models for Luciferase Hydroperoxide Intermediates and the Effect of Substituents at the 8-Position of Flavin on Luciferase Kinetics," *Biochemistry*, vol. 32, no. 2, pp. 404–411, 1993.
- [11] B. Chemi-, L. M. Luminometry, and T. Atp, "An Introduction to Chemiluminescence and Bioluminescence Measurements," pp. 1–12, 2002.
- [12] V. Takke, N. Behary, A. Perwuelz, and C. Campagne, "Studies on the Atmospheric Air – Plasma Treatment of PET ( Polyethylene Terephthalate ) Woven Fabrics : Effect of Process Parameters and of Aging," 2009.
- [13] A. Mohamed *et al.*, "Activity of enzymes immobilized on plasma treated polyester," *J. Mol. Catal. B Enzym.*, vol. 134, no. December, pp. 261–272, 2016.
- [14] Y. Yuan and T. R. Lee, *Contact Angle and Wetting Properties*. 2013.
- [15] F. Leroux, C. Campagne, A. Perwuelz, and L. Gengembre, "Atmospheric air plasma treatment of polyester textile materials. Textile structure influence on surface oxidation and silicon resin adhesion," *Surf. Coatings Technol.*, vol. 203, no. 20–21, pp. 3178–3183, 2009.
- [16] I. Gancarz and W. Tylus, "Plasma modified polymers as a support for enzyme immobilization II . Amines plasma," vol. 39, pp. 2217–2224, 2003.
- [17] C. Balny and J. W. Hastings, "Fluorescence and Bioluminescence of Bacterial Luciferase Intermediates," *Biochemistry*, vol. 14, no. 21, pp. 4719–4723, 1975.
- [18] S. E. Medvedeva, N. A. Tyulkova, A. M. Kuznetsov, and E. K. Rodicheva, "Bioluminescent Bioassays Based on Luminous Bacteria," *J. Sib. Fed. Univ. ( Biol. )*, vol. 2, no. 4, pp. 418–452, 2009.



# NEW FLUORESCENT AND COLORIMETRIC TEST KIT BASED CELLULOSIC TEXTILE FOR CYANIDE DETECTION

Souad FETTOUCHE<sup>1,2\*</sup>, Aicha BOUKHRISS<sup>1</sup>, Mohamed TAHIRI<sup>2</sup>, Omar CHERKAOUI<sup>1</sup>, Said GMOUH<sup>3</sup>

<sup>1</sup>Laboratoire REMTEX, ESITH, Route d'El Jadida, km 8, BP 7731 - Oulfa, Casablanca, Morocco, email: souad.fettouche@gmail.com

<sup>2</sup>Laboratoire Géosciences, Université Hassan II de Casablanca, Faculté des Sciences Ain Chock, B.P 5366 Maarif 20100, Casablanca, Maroc

<sup>3</sup>Laboratoire LIMAT, Université Hassan II de Casablanca, Faculté des Sciences Ben M'Sik, BP150- Ben M,sik Morocco

---

## ABSTRACT

*Cyanide is one of the most toxic inorganic anions as it is widely used in synthetic fibres, resins, herbicide and the gold-extraction process. However, it is an extremely toxic anion and can affect many functions in the human body, including the vascular, visual, central nervous, cardiac, endocrine and metabolic systems [1]. Thus, there is considerable interest in developing effective detection methods for cyanide anion. Currently, the development of molecular sensors for cyanide anions has been a subject of intense research interest [2]. In this work, we report a selective fluorescent and colorimetric sensor based azo dye for cyanide ion detection. The chromogenic and the fluorogenic behaviours toward various anions were investigated, the results showed an exclusive colorimetric and a fluorescence turn-on response for cyanide ions in aqueous solution (figure 1). Parameters that have influenced the detection of Cyanide by the developed sensor, such as (pH, CN<sup>-</sup> concentration, presence of other anions, etc.), have been studied. The sensor was immobilized on cellulosic textile, in reason to elaborate a test strips based on textile, which could act as a convenient and efficient CN<sup>-</sup> test kit.*

## KEYWORDS

*Cyanide (CN<sup>-</sup>), colorimetric; fluorescence switch; highly selectivity; azo dye; test strip based textile*

---

## INTRODUCTION

The cyanide ion and its protonated form, hydrogen cyanide (HCN), are extremely toxic. Cyanide impairs cellular respiration by inhibiting cytochrome c oxidase, an enzyme in the electron transport chain. Impairment of respiration causes cell death and suffocation and is a cause for concern in ecosystems in which concentrated cyanide accumulates. Additionally, cyanide exposure can cause adverse effects in the nervous, vascular, and endocrine systems of humans [3]. The cyanide ion is required for many industrial processes, such as the production of different chemicals, metals, and medicines [4]. For example, in the gold mining industry, HCN is released into the environment and is often found in waste water [5]. Additionally, the miners themselves can encounter gaseous hydrogen cyanide in the mines [4]. Gaseous cyanide can also be encountered during a house fire, in which burning materials release the chemical to the air [6].

Thus, detection of cyanide presence in water reservoirs and in biomedical applications has become a widespread cause of concern. Traditional methods of cyanide detection, such as titrimetric methods or potentiometric methods, are expensive and require relatively long amounts of time to complete. However, optical sensor compounds [3] or chromogenic sensors [4], which can bind to cyanide and display a visual colour or fluorescence change, can quickly and inexpensively detect the quantity of cyanide in solution, such as a water or blood sample [3].

In our case, we have developed an azo dye colorimetric ligand for  $\text{CN}^-$ . The azo dye was synthesized and characterized by FT - IR, NMR and HRMS spectroscopy. Based on the colorimetric response of elaborated azo (chemosensor) dye to  $\text{CN}^-$ , textile-based test strips containing chemosensor were prepared by dyeing, which also exhibited good sensitivity and selectivity to  $\text{CN}^-$  in aqueous media. The quantitative detection of  $\text{CN}^-$  using these fabrics was attempted and the colour variation tracking is carried out by the colour data.

## MATERIALS AND METHODS

### Materials

2- methoxy, 5- methylaniline, 3- hydroxynaphtalene - 2,7- disulfonic acid disodium salt, sodium hydroxide (NaOH), carbonate sodium ( $\text{Na}_2\text{CO}_3$ ), sodium nitrite ( $\text{NaNO}_2$ ), metal salts LiCl,  $\text{NaNO}_3$ ,  $\text{Ba}(\text{NO}_3)_2$ ,  $\text{Cu}(\text{NO}_3)_2$ ,  $\text{Al}_2(\text{SO}_4)_3$ ,  $\text{HgCl}_2$ ,  $\text{NiSO}_4$ ,  $\text{CdSO}_4$ ,  $\text{Co}(\text{NO}_3)_2$ ,  $\text{Zn}(\text{NO}_3)_2$ ,  $\text{Pb}(\text{NO}_3)_2$ , KCl,  $\text{FeSO}_4$ ,  $\text{FeCl}_3$  were purchased from Sigma Aldrich. Hydrochloric acid (HCl), Ethanol (EtOH) were purchased from Solvachim. All chemicals were of analytical grade and used without further purification. A colorimetric sensor based-azo dye (CO) woven fabric weighing  $168 \text{ g} \cdot \text{m}^{-2}$  was used.

### Synthesis of (E)-3- hydroxy-4- ((2- méthoxy-5- methylphyl) diazenyl) naphtalene - 2,7- disulfonic acid

The ligand was prepared through a simple synthetic route (Figure 1) according to two step. In the first step, the synthesis of aromatic diazonium salt from 2-methoxy, 5-methylaniline was carried out. In the second step, the obtained diazonium salt was coupled with the aromatic compound 3-hydroxynaphtalene -2, 7- disulfonic acid disodium salt in alkaline media [7].

#### *Procedure of synthesis*

4- chloroaniline (1 equation) was mixed with iced water and/or absolute EtOH (2 mL by mmol of reagent) and stirred at  $0^\circ\text{C}$  then hydrochloric acid 37% (4 equation) was added dropwise rapidly. Sodium nitrite (1.1 equation) was added below  $2^\circ\text{C}$  and reaction mixture was stirred at  $0-2^\circ\text{C}$  for 30 min. 3- hydroxynaphtalene -2,7- disulfonic acid disodium salt (1.1 equation) was dissolved in iced water (10 mL by mmol of reagent) then pH was adjusted to 9 by adding NaOH 30% solution. The diazonium

salt was coupled in alkaline media (pH 9) below 2°C by adding NaOH 10% solution. After complete addition of the diazonium salt to the 3-hydroxynaphthalene- 2,7- disulfonic acid disodium salt, stirring was maintained at 0°C for 2 h. The result dye was purified by recrystallization from EtOH/(H<sub>2</sub>O) (4/1) with a reaction yield of 84%.

FT-IR (cm<sup>-1</sup>): 3480(-OH), 1503(-N=N-), 1186(-S=O), 1492 (aromatic ring).<sup>1</sup>H NMR (300 MHz, D<sub>2</sub>O, δppm) 8.186 (s, 2H, aromatic), 8.075 (s, 2H, aromatic), 7.59-7.56 (d, 2H, J=6.6 Hz, aromatic), 7.505-7.476 (d, 2H, J = 8.70 Hz, aromatic), 4.673 (s, 1H, OH), 2.13 (s, 2H,SO<sub>3</sub>H).

<sup>13</sup>C NMR (300 MHz, D<sub>2</sub>O, δppm) 169.59, 145.15, 141.198, 133.600, 133.014, 130.71, 130.322, 130.232, 130.147, 129.924, 128.910, 126.997, 124.765, 123.412, 122.396, 121.625 and 116.686.

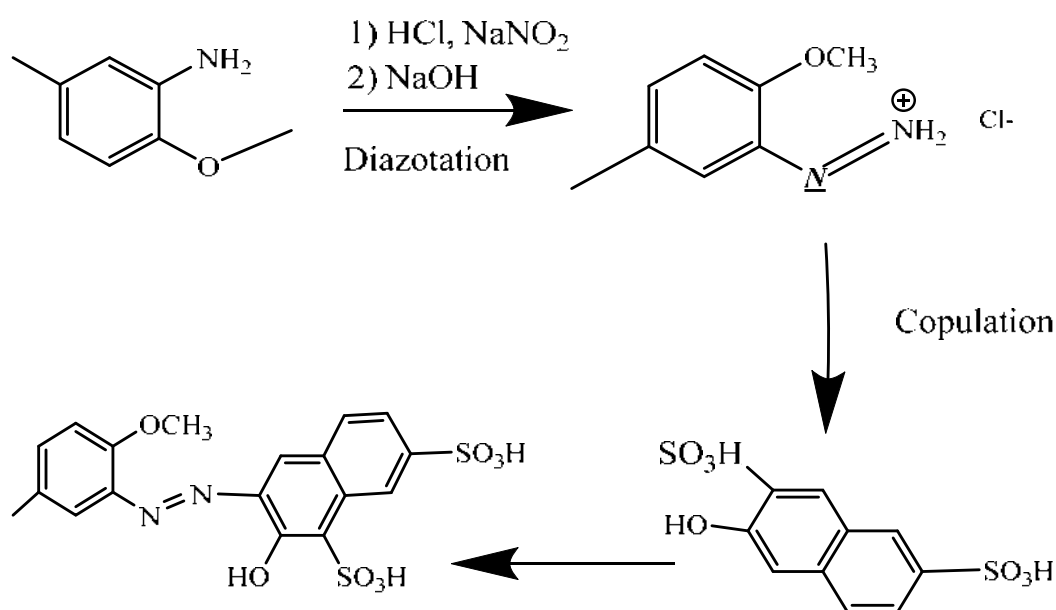

Figure 1. The scheme explaining the synthesis route of Ligand 1

#### FT-IR spectra

The infrared spectra were recorded on a Nicolet iS10 FTIR-ATR spectrophotometer.

#### RMN

<sup>1</sup>H NMR and <sup>13</sup>C NMR spectra were recorded on Bruker Avance (300 MHz) apparatus using TMS as internal reference.

#### General procedure of dyeing

Cotton fabric was dyed using ligand 1 in Ahiba Polymat dyeing machine at a material to liquor ratio of 1:20. Fabric was dyed using 2% dye (calculated on weight of the fabric). The unifying agent 40%. The carbonate sodium Na<sub>2</sub>CO<sub>3</sub> 40%. The percentages of dye are 1, 3, 5 and 10% by weight of textile.

Dyeing started at room temperature. The dye bath temperature raised at a rate of 1.5°C/min to 98°C, maintained at this temperature for 45 min and cooled to room temperature.

#### *Colour measurement*

Colour coordinates of dyed cotton fabric were measured by Datacolor SF600. Spectral range of Datacolour is from 360 nm to 700 nm. Light source of device is pulsed xenon lamp. Colour difference between two fabrics was calculated using the following formula:

$$\Delta E = [(\Delta L)^2 + (\Delta a)^2 + (\Delta b)^2]^{1/2} \quad (1)$$

Where  $\Delta E$  is the amount of total change in colour,  $\Delta L$  is the change in strength;  $\Delta a$  and  $\Delta b$  are the change in hue and chroma, respectively [8].

## **RESULTS AND DISCUSSION**

### **Sensing of anion**

The sensing properties of sensor 1 toward anions such as Br<sup>-</sup>, AcO<sup>-</sup>, NO<sub>3</sub><sup>-</sup>, SO<sub>4</sub><sup>2-</sup>, Cl<sup>-</sup>, I<sup>-</sup>, F<sup>-</sup>, CN<sup>-</sup> and H<sub>2</sub>PO<sub>4</sub><sup>-</sup> in aqueous solution (0.05M Tris buffer, pH 7.4, 50% DMF) was studied through UV-Vis, naked eye color changes and fluorescence (Fig. 2a) shows a remarkable color change from purple to faint orange (hypsochromic shift) upon the addition of CN<sup>-</sup> ions. While, other tested anions did not show any colorimetric change. Moreover, when the chemosensor was excited at 365 nm in the presence of 1000 equiv. of other anions, a bright blue fluorescence response was selectively observed only in the presence of cyanide in the solution of 25µM of the sensor (Fig. 2b). To study the sensing abilities and spectral responses, the absorption spectra of chemosensor 1 (25µM) were recorded by adding various anions (1000 Equivalent). As shown in Fig. 3, upon interaction of chemosensor 1 with CN<sup>-</sup> ions, a new band was observed at 311 nm. On the other hand, no significant spectral change was observed upon the addition of other tested anions.

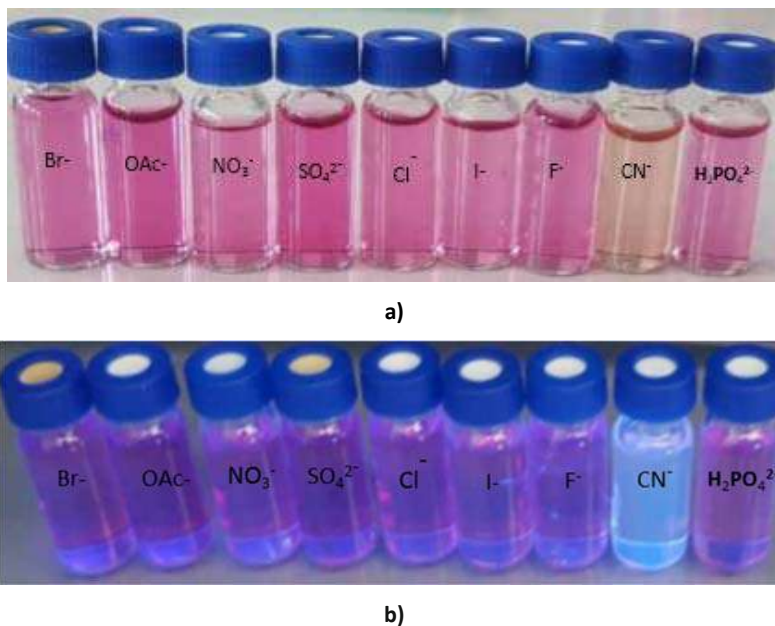

Figure 2. (a) Visual color changes of 1 (25  $\mu\text{M}$ ) in the presence of 1000 equivalents of different anions, (b) Fluorescence responses of 1 (25  $\mu\text{M}$ ) in the presence of 1000 equivalent of different anions

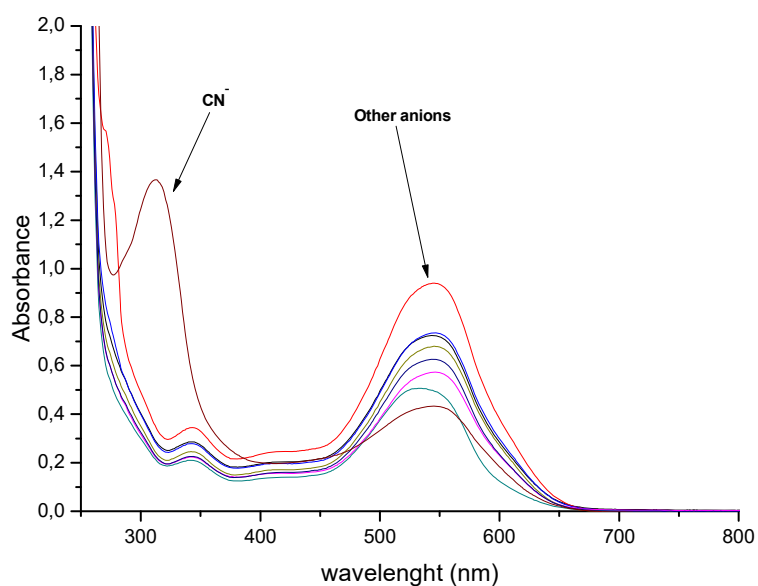
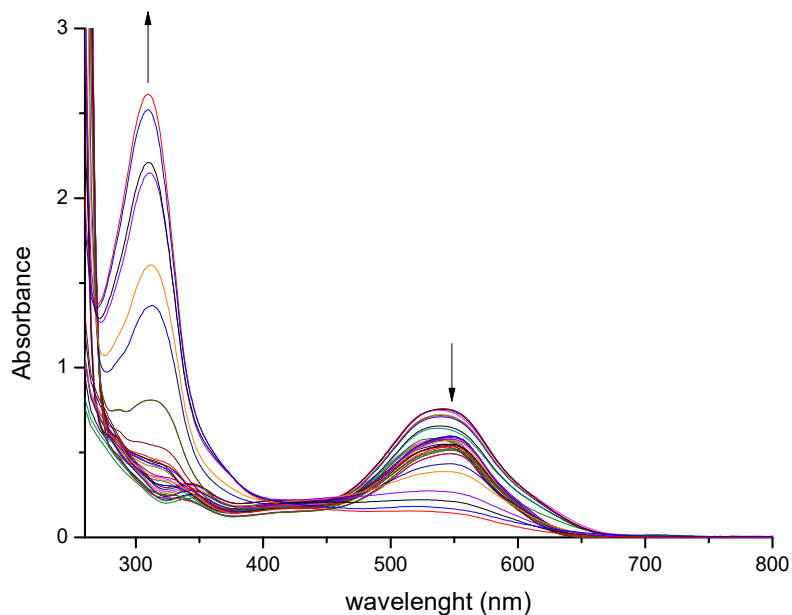

Figure 3. UV-Vis spectra changes of 1 (25  $\mu\text{M}$ ) upon addition of 1000 equiv. of different anions

To further investigate the interaction between chemosensor 1 and  $\text{CN}^-$ , UV-Vis absorption spectral variation of 1 was monitored during titration with different concentrations of  $\text{CN}^-$ . As shown in Fig. 4a, the gradual decrease of absorption band at 549 nm and the increase of a new absorption band at 311 nm was observed, resulting in a color change from purple to faint orange as observed by the naked-eye upon the addition of different amounts of  $\text{CN}^-$  ions to 1 (Fig. 4b). Simultaneously, the

isobestic point at 404 nm in 1-CN<sup>-</sup> demonstrated that 1 reacted with CN<sup>-</sup> anions to form stable specie [9].



a)



b)

Figure 4. a) UV-Vis spectra of 1 (25 $\mu$ M) upon adding of an increasing concentration of CN<sup>-</sup>; b) Photographs of 1 (25 $\mu$ M) with CN<sup>-</sup> ranging from 0- 9000 Equiv. from right to left.

To confirm the selectivity of sensor 1, various anions including Br<sup>-</sup>, AcO<sup>-</sup>, NO<sub>3</sub><sup>-</sup>, SO<sub>4</sub><sup>2-</sup>, Cl<sup>-</sup>, I<sup>-</sup>, F<sup>-</sup> and H<sub>2</sub>PO<sub>4</sub><sup>-</sup> contacting with 1 were investigated by UV-Vis absorption. Among various anions, only the addition of cyanide displayed noticeable color changes from purple to brown. UV-Vis spectra showed that 1 had a high selectivity for cyanide ion.

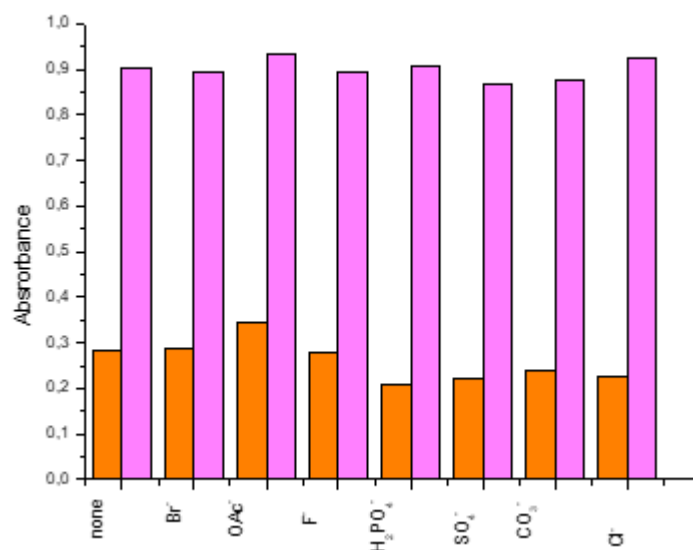

Figure 5. Absorbance spectra of 1 (25 $\mu$ M) in the presence of various anions (1000equiv.) in DMF/H<sub>2</sub>O (1:1, v/v, containing TRIS Buffer PH=7.4) in response to CN<sup>-</sup> (1000equiv.)

### Application on textile

To confirm the practical application of 1 in aqueous media. Cotton-based textiles were used. These textiles were prepared by dyeing process with 5 % of dye concentration. The result showed that the textile have a colorimetric response for Cu<sup>2+</sup> cation. Indeed, the sensing properties of dyed textile toward various metal ions were examined by immersion fabrics of 1.5 cm x 1.5 cm in a water solution (400  $\mu$ M) of various metal: Br<sup>-</sup>, AcO<sup>-</sup>, NO<sub>3</sub><sup>-</sup>, SO<sub>4</sub><sup>2-</sup>, Cl<sup>-</sup>, I<sup>-</sup>, F<sup>-</sup> and H<sub>2</sub>PO<sub>4</sub><sup>-</sup>. As observed, textile exhibited a very distinctive selectivity to copper ions. When ligand 1 was treated with a series of individual metal ions in water, only Cu<sup>2+</sup> showed a dramatic color change from orange to pale yellow. In contrast, the other metal ions did not show any significant color change (Fig. 2a). A color gradient from deep orange to pale yellow was clearly observed upon decreasing the concentration of CN<sup>-</sup> (0.1 $\mu$ M – 40 mM), allowing a semiquantitative estimation of the sample concentration in water by simple visual analysis (Fig. 2b).

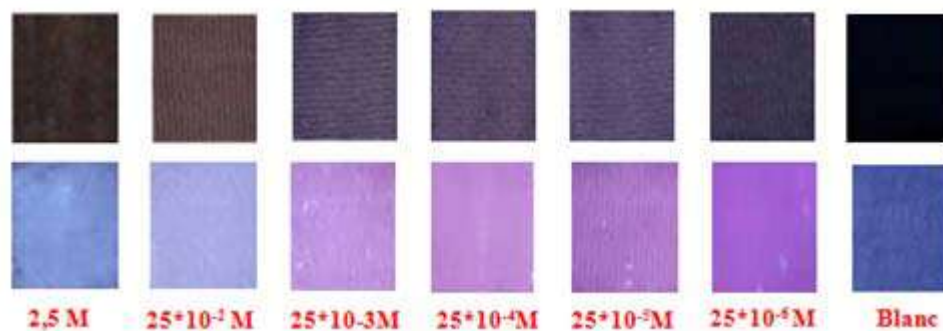

Figure 6. Variation of colors for textiles with different concentrations of cyanide anions

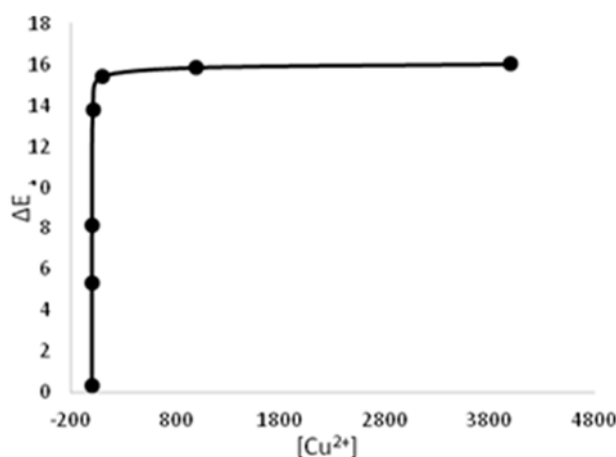

Figure 7. Variation of colors ( $\Delta E$ ) for textiles with different concentrations of  $CN^-$

Upon immersion of textile in solutions with increasing amounts of  $Cu^{2+}$ , the  $\Delta E$  value was increased as a function of the concentration of copper ions and remains stable at 0.1 mM (Fig. 3b).

## REFERENCES

- [1] Sidell, F.R., E.T. Takafuji, and D.R. Franz, Medical aspects of chemical and biological warfare, 1997, OFFICE OF THE SURGEON GENERAL (ARMY) FALLS CHURCH VA.
- [2] Zhang, P., et al., A naphtholic Schiff base for highly selective sensing of cyanide via different channels in aqueous solution. *Dyes and Pigments*, 2013. 99(3): p. 857-862.
- [3] Xu, Z., Chen, X., Kim, H.N., Yoon, J. Sensors for the optical detection of cyanide ion. *Chemical Society Reviews*. 2010, 39, 127-137.
- [4] Randviir, E. P.; Banks, C. E. The latest developments in quantifying cyanide and hydrogen cyanide. *Trends in Analytical Chemistry*. 2015, 64, 75-85.
- [5] Johnson, C.A. The fate of cyanide in leach wastes at gold mines: An environmental perspective. *Applied Geochemistry*. 2014, 1-12.



- [6] Männel-Croisé, C., Zelder, F. Rapid visual detection of blood cyanide. *Analytical Methods*. 2012, 4, 2632-2634.
- [7] Favre-Besse, F. C., Poirel, O., Bersot, T., Kim-Grellier, E., Daumas, S., El Mestikawy, S. & Pietrancosta, N. Design, synthesis and biological evaluation of small-azo-dyes as potent Vesicular Glutamate Transporters inhibitors. *European journal of medicinal chemistry*, (2014), 78, 236-247.
- [8] Colleoni, C., Massafra, M. R., Migani, V., & Rosace, G. Dendrimer finishing influence on CO/PES blended fabrics color assessment, *Journal of applied polymer science*, (2011), 120(4), 2122-2129.
- [9] Davis, A.B., Lambert, R.E., Fronczek, F.R., Cragg, P.J., Wallace K.J. An acitivated coumarin-enamine Michael acceptor for CN-. *New Journal of Chemistry*. 2014, 38, 4678-468

# INVESTIGATING OF SILICA-CINNAMON HYBRID COTTON MATERIALS - PREPARATION AND CHARACTERIZATION FOR MEDICAL APPLICATION

**Maja SOMOGYI ŠKOC<sup>1\*</sup>, Iva REZIĆ<sup>1</sup>, Kristina GAŠPARAC<sup>1</sup>**

<sup>1</sup>University of Zagreb Faculty of Textile Technology, Prilaz baruna Filipovića 28a, 10000 Zagreb, Croatia, \*email: maja.somogyi@ttf.hr

---

## ABSTRACT

*Silica-cinnamon hybrid materials were prepared and characterized as a potential new material for medical application - medical textiles, i.e. wound dressings. Cinnamomum verum (cinnamon) contain compounds with a wide range of proven antibacterial, antiviral, antipyretic, anti-inflammatory and antifungal properties. Silica-cinnamon cotton fabrics were prepared by dip-coating from 3-glycidyloxypropyltrimethoxysilane (GLYMO) as a precursor with catalyst and with commercially available powder of cinnamon. The aim was to achieve cinnamon evenly distributed and represented along the fibres, still present in sufficiently quantity after laundering. The coatings were characterized by infrared spectroscopy (FTIR-ATR), scanning electron microscopy (SEM) and drop test.*

## KEYWORDS

*Sol-gel, medical textiles, natural compounds, nanoparticles*

---

## INTRODUCTION

Textile materials have wide application in medicine, surgery and health protection. Important place is taken to design/to provide adequate modification of textile material as a potential new material for medical application i.e. wound dressings. Contemporary medicine requires textile materials with specific properties. The most significant of these are textile materials with antimicrobial activity that have the ability to prevent growth and development of pathogenic microorganisms. When microorganisms formed biofilm, it is hard to stop colonization. Biofilm is a well-organized colony of bacteria clustered together to form micro colonies. These colonies of bacteria attach to surfaces where they assume different characteristics from free-floating bacteria [1]. Medicine in that case, depending on the situation carried out mechanical cleaning or they are using many different drugs directly applied and supported with specially designed wound dressings.

The actual mechanism behind the biofilm formation is still unknown and will remain a hot topic of scientific research for many years. Nevertheless, it is known that the biofilm composition and the mechanisms involved are related to the resistance and virulence of the microbes [2]. The application of nanotechnology in drug delivery systems and in the textile parts of wound dressings has enormous

potential and can be considered as an effective alternative for the treatment of microbial biofilms in the near future.

Sol-gel process in recent years has proved to be suitable for textile processing and achieving antimicrobial activity with various nanoparticles from silver, copper, zinc etc. This work was design for investigation of preparation and characterization of bioactive medical textiles with natural active substances. That stage was analyse in this work and it is basis for testing to antimicrobial resistance. First, we need to ensure good homogenous properties of sol-gel modification with natural active substance in the powder form.

The use of inorganic and organic substances with the addition of natural active substances enables the preparation of bioactive medical textiles of unique properties with the possibility of gradual release.

As an ideal substrate for this, suitable cellulose fibres are due to their well-known properties (e.g., a large active surface) and are readily available on the market.

In order to prevent pollution and reduce the risk of illness, the use of chemicals means is reduced to a minimum and tried to be replace by more environmentally friendly bioactive means [3].

Almost all of the natural active ingredients are safe to use, are non-toxic and do not slip skin, and do not have any adverse environmental impact. For safe use, the chemical composition of plant active substances and their function in the body should be known for a better understanding of the use of certain medicinal plants.

Sol-gel treatment with bioactive agents offers many possibilities in the preparation of functional medical textiles. Thus, in the researches, a sol-gel process was employed using bioactive oil of night cauliflower and wild sesame to obtain skin-resistant anti-microbial and anti allergic textile, and textile for the therapeutic treatment of respiratory tract with a mixture of essential oils of eucalyptus, camphor and menthol. The results showed satisfactory antimicrobial and medicinal properties and good wash resistance [4].

Numerous antimicrobial agents (garlic, honey, turmeric, ginger, etc.) are used to develop bioactive textiles, and one of these is cinnamon too. Through the history of different cultures, they have recognized the potential of using cinnamon as an antimicrobial agent as it is used for the prevention and treatment of various diseases.

Cinnamon (*Cinnamomum ceylonicum* and *Cinnamomum cassia*) was known throughout the world with its exotic flavour (Fig. 1). The Arabs first introduced it to the west and its trade route spread all the way to China. Being present all over the world, different cultures have been used for various purposes. Therefore, the Egyptians used it for embalming, perfumes, essential oils and as a drink [5].



Figure 1. The plant of cinnamon [6]

The basic characteristics of Ceylon cinnamon are brighter colours, unusual sweet, gentle, warm and pleasant aroma and a distinct smell. It contains 1.5 to 4% of essential oil, consisting mainly of cinnamom aldehyde and eugenol (2-methoxy-4- (prop-2-en-1-yl) phenol) [7].

Cinnamon has now found, besides the spice, its other less important role. Cinnamon is attributed to beneficial effects on health. The healing properties of cinnamon can be thanked to the three basic ingredients of essential oils found in the tree. Essential oils contain active substances cainamaldehyde, cinnamyl acetate, cinnamyl alcohol. Cinnamon works beneficial to the digestive system, relieves pain, acts as a suppressant and diarrheal agent. Stimulates digestion and circulation. It has strong antibacterial activity, helps in urinary tract infections, reduces blood sugar levels and treats fungal and bacterial infections [8].

## EXPERIMENTAL

### Materials and Methods

The code of samples used in this work is showed in Table 1.

Table 1. Sample and processing labels used in this work

Code	Sample/treatment	Treatment and amount of cinnamon
0	/	untreated
1	Cotton / GLYMO; HCl; 1:1,5;	mass of cinnamon: 2 g, thermostatic
2	Cotton / GLYMO; HCl; 1:1,5;	mass of cinnamon: 4 g, thermostatic
3	Cotton / GLYMO; HCl; 1:1,5;	mass of cinnamon: 6 g, thermostatic
4	Cotton / GLYMO; HCl; 1:1,5;	mass of cinnamon: 2 g, UZV
5	Cotton / GLYMO; HCl; 1:1,5;	mass of cinnamon: 4 g, UZV
6	Cotton / GLYMO; HCl; 1:1,5;	mass of cinnamon: 6 g, UZV
7	/	powder of cinnamon

For the preparation of hybrid materials, precursor 3-glycidyloxypropyltrimethoxysilane, GLYMO (98% Aldrich, M = 236.34 g/mol) was used. Hydrogen chloride (37% Aldrich, M = 36.46 g/mol) was selected as the catalyst for hydrolysis of GLYMO. As a natural active substance, the cinnamon of

company Lebensbaum (Diepholz, Germany) was used. Appropriate amount (2 g, 4 g and 6 g) of natural active ingredient – cinnamon was added in sol during the homogenization. To prepare the sol-gel coating, the sol is homogenized in two different ways:

1. in a special glass flask for thermostatics to ensure constant test conditions and to meet the basic conditions of preparation (according to previous knowledge) [9],
2. in ultrasonic bath at 30 kHz for 15 min, where deionized water was used as the medium (Elma Elmasonic P Elastomer ultrasonic bath).

Homogenized mixtures are separately prepared for each of the above-mentioned treatments. Sol poured into teflon containers and then the samples (cotton fabric) were immersed with a custom-made apparatus with the predetermined drawing speed to obtain a thin coating at a speed of 1 mm/s. Modified cotton fabric samples were left to gel at room temperature for 24 hours, and then dried at 110 ° C for 1 h. In this way, the hydrolysis of the GLYMO alkoxide groups with air moisture was enable. Samples of 5 x 5 cm<sup>2</sup> in size were dip-coated.



Figure 2. Custom-made apparatus for dip-coating

Analysis of the modified samples was performed by spectroscopy in the infrared field on the Perkin Elmer Spectrum 100 FTIR apparatus, with ATR (FTIR-ATR) in 400 to 4000 cm<sup>-1</sup> interval. All spectra at room temperature were recorded.

Surface structure and morphological characteristics of unmodified and modified samples were investigated on the scanning electron microscope of the manufacturer TESCAN VEGA III EASYPROBE with working voltage of 20 kV. The images were performed with an magnification of 500x, 2000x and 5000x, and the samples were treated with gold/palladium (Au/Pd) to get the best results of morphology of sol-gel coatings.

The effect of processing by sol-gel on the hydrophilicity of textile materials was determined and the following test procedure was applied: AATCC 79-2000 Absorbency of Bleached Textiles with a volume drop of 0.2 ml. The method is known also as a drop test.

## RESULTS AND DISCUSSIONS

Characterization of untreated samples was done according to the usual textile characterization, wherein the basic characteristics: composition of raw material (cotton 100%, twill weave), the mass per unit area (176 g/m<sup>2</sup>) according to HRN ISO 3801, the thickness of the fabric (0.49 mm) according to HRN EN ISO 5084 and thread density (warp/weft: 24/35 threads/cm) according to HRN EN 1049-2.

### The results of determining the IR spectrum (ATR-FTIR)

For comparison of FTIR spectra, all are normalized from 4000 to 400 cm<sup>-1</sup>, with a resolution of 4 cm<sup>-1</sup>, accumulating 120 scans, at the highest ordinate value with a large number of pixels from Fig. 2 to Fig. 3.

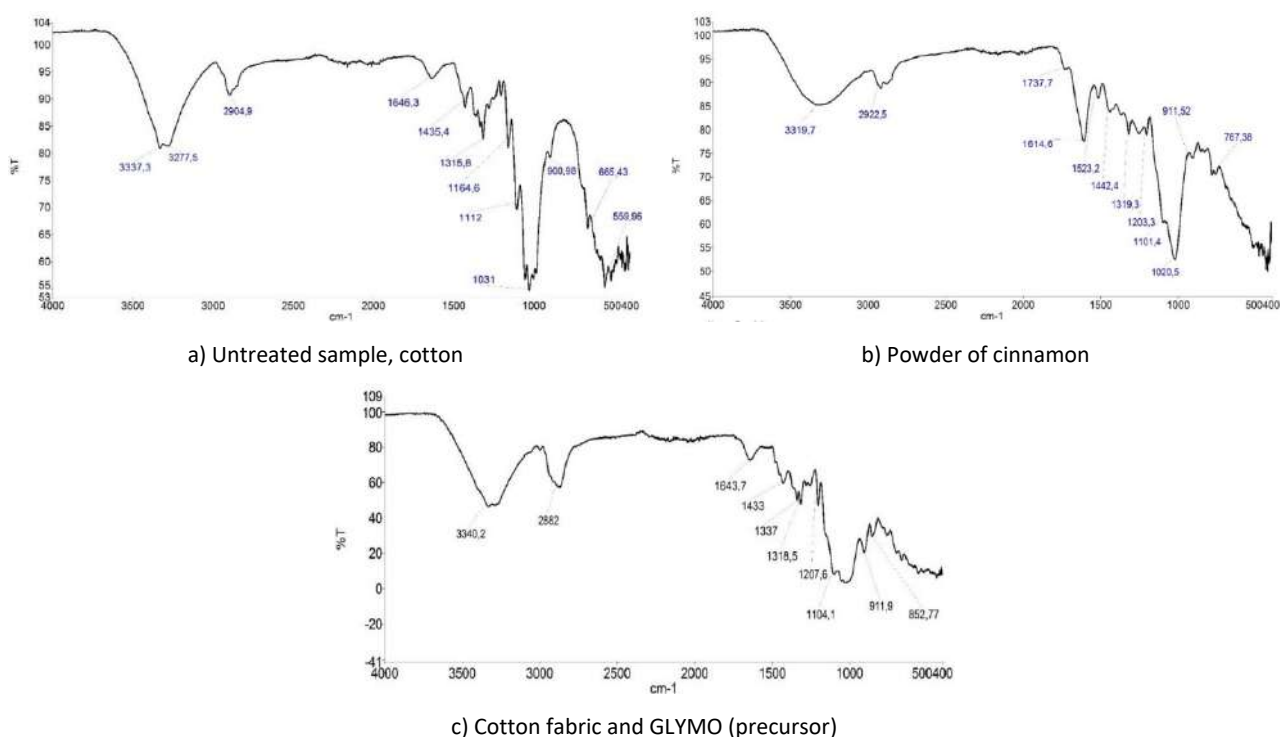

Figure 2. FTIR spectra a) untreated sample, b) powder of cinnamon, c) cotton fabric and GLYMO (precursor)

From Figure 2c), where the spectrum of cotton fabric and GLYMO is shown, very similar functional groups (N-H (3340,2 cm<sup>-1</sup>), C-H (2882 cm<sup>-1</sup>), C-C (1643,7 cm<sup>-1</sup>), C-C (1433 cm<sup>-1</sup>), N-O (1337 cm<sup>-1</sup>), C-O (1318,5 cm<sup>-1</sup>), C-N (1207,6 cm<sup>-1</sup>), C-N (1104,1 cm<sup>-1</sup>), O-H (911,9 cm<sup>-1</sup>), C-H (852,7 cm<sup>-1</sup>) are observed for untreated cotton (Fig. 2a), O-H band (3337-3277 cm<sup>-1</sup>), C-H (2904 cm<sup>-1</sup>), C-C (1646 cm<sup>-1</sup>), C-H (1435 cm<sup>-1</sup>), C-H (1315 cm<sup>-1</sup>), C-C (1164 cm<sup>-1</sup>), C-OH (1112 cm<sup>-1</sup>), C-OH (1031 cm<sup>-1</sup>), C-H (900 cm<sup>-1</sup>). No preparatory process was carried out on the textile substrate prior to dip-coating (no scouring, bleaching etc.) and this may be due fact that modified cotton fabric has starches, pectin and waxes

who are covering the cellulose. It is seen that with the addition of GLYMO some peaks become more intense.

The literature data on functional groups of cinnamon in powder was used in this paper and they are seen on the Fig. 2b) [10].

Figure 2c) showed the formation of silanol groups overlapping –OH groups (reflected in the appearance of –OH bands at 3300 cm<sup>-1</sup>) and the decrease in the band at 2900 cm<sup>-1</sup>, attributed to C-H bonds.

By analysing the FTIR spectrum in Figure 3 where is the fundamental difference in homogenization of the sol, ultrasonic (Figure 3a, c, e), thermostatic (Figure 3b, d, f), it is apparent that there are no strongly significant differences in the present bands.

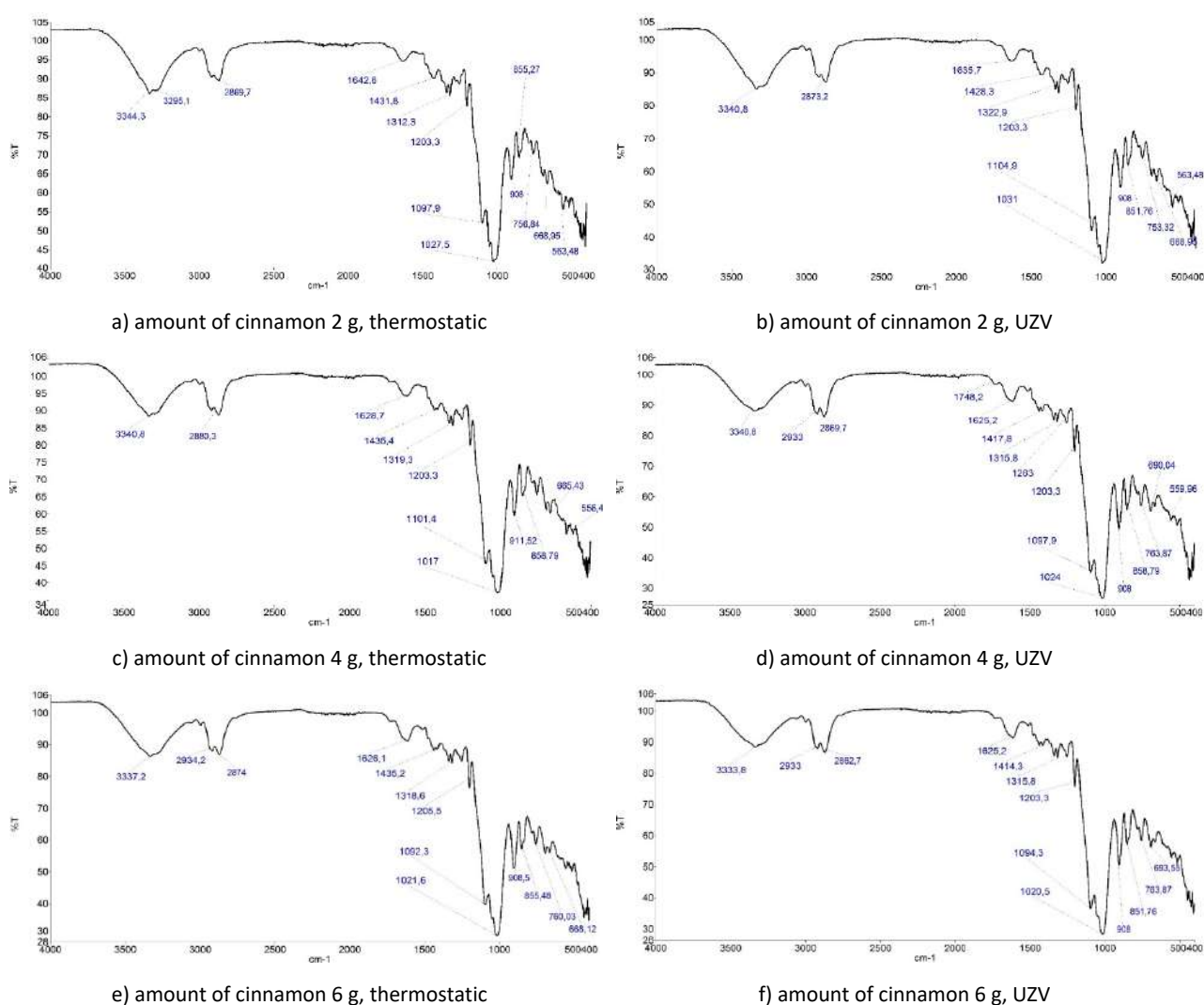

Figure 3. FTIR spectra a) amount of cinnamon 2 g, thermostatic, b) amount of cinnamon 2 g, UZV, c) amount of cinnamon 4 g, thermostatic, d) amount of cinnamon 4 g, UZV, e) amount of cinnamon 6 g, thermostatic, f) amount of cinnamon 6 g, UZV

What is apparent from the FTIR spectrums in Figure 3 is that all showed the characteristics Si-O bands at 1100-1000  $\text{cm}^{-1}$ , which indicated the presence of silica network. On untreated cotton fabric is also seen absorption band at 1031  $\text{cm}^{-1}$  (Fig. 2a) and also on the Fig. 2b (cinnamon powder) it is seen at 1020  $\text{cm}^{-1}$ . But, only modified samples have epoxy ring band at 904  $\text{cm}^{-1}$ , which confirmed the formation of a hybrid film on the surface of the fabric.

The conversion of methoxide groups of GLYMO (reduction band at 2870  $\text{cm}^{-1}$ ) was comparable. All FTIR spectra showed the area of silicate netting which has been overlapped with characteristic cotton groups and it is difficult to conclude with certainty which groups are formed and which are not. In order to obtain additional insight into the modification, SEM analysis was performed.

### The results of morphological characteristics (SEM)

Surface coatings of untreated samples and samples with the addition of cinnamon powder modified by sol-gel process on cotton fabric are showed in Table 2.

Table 2. Surfaces of cinnamon-hybrid cotton samples - 6 g

Code.	500x	3000x	5000x
0			
3			



6

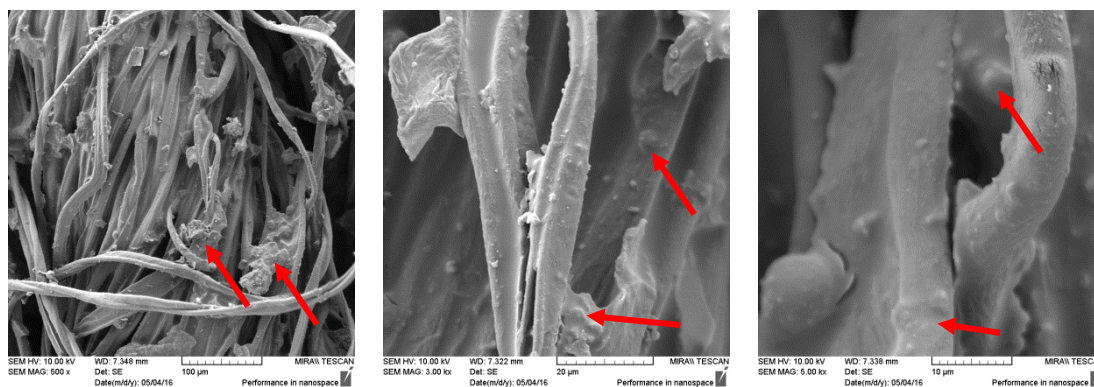

Where is 0 – untreated sample; 3 – cinnamon 6 g (thermostatic), 6 - cinnamon 6 g (UZV)

From Table 2 untreated sample, the cotton showed a characteristic twist. By analysing the SEM image of modified cotton fabric by ultrasound (homogenized), the coating is uniform, with different size of cinnamon powder. Cinnamon powder varying in size, as well as forming smaller or larger agglomerates (some agglomerate places are pointed on the Figures).

By analysing the SEM images of the modified cotton, thermostatic (homogenized), the coating were observed on each fiber separately. The coating is uniform, with cinnamon powder of different sizes and shapes in the form of smaller agglomerates, as well uniformly distributed over the entire length of the fiber.

From Table 2 it can be concluded that processing where the sol homogenized in the thermostat is visually significantly uniform.

### The results of drop test

Table 3 shows the results of the test drops, i.e. the time of absorption of the untreated sample and the samples modified by the sol-gel process with the addition of bioactive substances, i.e., cinnamon. The drop time was determined by a solution of methylene blue. The methylene blue was used to better detect the drop shape on the tested sample.

Table 3. Test results by drop test

Code	Treatment and amount of cinnamon	t[s]
0	untreated	> 300
1	mass cinnamon 2 g, thermostatic	> 300
2	mass cinnamon 4 g, thermostatic	> 300
3	mass cinnamon 6 g, thermostatic	> 300
4	mass cinnamon 2 g, UZV	> 300
5	mass cinnamon 4 g, UZV	> 300
6	mass cinnamon 6 g, UZV	> 300

In this paper, raw cotton fabric for a special medical purpose, targeted not been "cleaned" in order to gain insight into the behaviour of samples with and without the sol-gel coating. Primarily, the shape of drops was observed and the drop retained its proper shape in the same way as in all samples. The fact is that the raw cotton fabric has a hydrophobic character with respect to starch, as well as the sol-gel process itself. This test was verified and confirmed as a hydrophobic character as the goal was to release active cinnamon from the coating to the environment.

## CONCLUSIONS

With this work homogenization was performed in two ways where homogenization in a classic way - in the thermostat was shown to be more effective in reducing the small particles in the sol so that they became uniformly distributed. This is confirmed by SEM images. They are showing the coating on each fiber separately (as opposed to ultrasonic homogenisation). The coating is uniform, with particles of cinnamon different in size and shape, in the form of very small agglomerates, while the powder are uniformly distributed over the entire length of the fiber.

The FTIR spectra of results indicate the area of silicone formation, Si-O-C and Si-O-Si ( $1053\text{ cm}^{-1}$ ,  $1102\text{ cm}^{-1}$ ), but covered to the functional groups for cellulose. Since there is no sharp point at  $2901\text{ cm}^{-1}$  for the modified samples as in the initial sample, it is assumed that a conversion of the GLYMO methoxide groups has occurred, as the bandwidth of  $2926.5$  to  $2874.4\text{ cm}^{-1}$ . Cinnamon amount does not have a significant effect on stronger or weaker groups in FTIR spectra. The results of the drop test performed indicated the hydrophobic samples with the proper form drops.

The preparation and characterization of bioactive medical textiles with natural active substances by the sol-gel process represents a scientific breakthrough in theoretical and applicative terms, since with well-laid processing conditions and the addition of sufficient amount of cinnamon offers a completely new modification of textiles with the possibility of developing a new product.

### *Acknowledgements*

This work was supported by short-term financial support of the University of Zagreb, Croatia, Testing of antimicrobial properties of mixtures of nanoparticles in polymers for sports cycling equipment, coordinator: assoc. prof. Iva Rezić, PhD. PhD. [IP1/18].

The authors would like to thank to prof. Jelena Macan, PhD for the measurements of SEM at the Department of Physical Chemistry of the University of Zagreb Faculty of Chemical Engineering and Technology.

## REFERENCES

- [1] Biofilm, Available from: <https://medical-dictionary.thefreedictionary.com/biofilm>, Cited: January, 2019
- [2] Dos Santos Ramos M. A., Da Silva P. B., Spósito L., De Toledo L. G., Bonifácio B. V., Rodero C. F., Dos Santos K. C., Chorilli M., Bauab T. M. Nanotechnology-based drug delivery systems for control of microbial biofilms: a review. *International Journal of Nanomedicine*. 2018; 13: 1179–1213.
- [3] Gouveia C. I. Nanobiotechnology: A new strategy to develop non-toxic antimicrobial textiles. *Formatex* 2010. [Cited: January 2019] *Current Research, Technology and Education Topics in Applied Microbiology and Microbial Biotechnology*. Mendez-Vilas A. (ed.). Available from: <http://www.formatex.info/microbiology2/407-414.pdf>
- [4] Haufe H., et al. Bioactive textiles by sol-gel immobilised natural active agents. *Journal of Sol-Gel Science Technology* 2008; 5: 97–101
- [5] Cinnamon. Available from: <https://en.wikipedia.org/wiki/Cinnamon>, Cited: January, 2019
- [6] Cinnamon. Available from: <https://encyclopedia2.thefreedictionary.com/Cinnamon+plant>, Cited: January, 2019
- [7] Pasupuleti V. R., Siew H. G. Cinnamon: A Multifaceted Medicinal Plant. *Evidence Based Complement Alternative Medicine*. 2014 Apr; 10: 1-12
- [8] 10 Evidence-Based Health Benefits of Cinnamon. Available from: <https://www.healthline.com/nutrition/10-proven-benefits-of-cinnamon>, Cited: January, 2019
- [9] Somogyi Škoc M., Macan J., Pezelj E. Modification of polyurethane-coated fabrics by sol-gel thin films. *Journal of Applied Polymer Science*. 2014; 131:39914-1-39914-13
- [10] Satish K., Yogesh M, Jigisha P. Optimization of Yield for Extraction of an Essential Oil from Cinnamon Using Microwave-Assisted Extraction. *Journal of Chromatography Separation Techniques*. [Internet]. 2017 [cited 2019 January]; Available from: <https://www.omicsonline.org/open-access/optimization-of-yield-for-extraction-of-an-essential-oil-from-cinnamon-using-microwaveassisted-extraction-2157-7064-S1-001.pdf>

# INTERACTION OF COLOUR AND SURFACE IN DECORATIVE TEXTILE PRODUCT DESIGN

**Marijana TKALEC<sup>1\*</sup>, Martinia Ira GLOGAR<sup>1</sup>, Ana MARIĆ<sup>1</sup>**

<sup>1</sup>University of Zagreb Faculty of Textile Technology, Prilaz baruna Filipovića 28a, 10000 Zagreb, Croatia, \*email: marijana.tkalec@ttf.hr

---

## ABSTRACT

*Interaction of colours, one of the most powerful design elements, together in harmonic relationship when creating a textile design pattern for a particular project, has the same importance as the interaction of the entire colouristic composition and the textile substrate on which it is reproduced. In this paper that contains artwork patterns intended for textile interior decoration products with an emphasis on the importance of subjective and objective understanding of the colour relationships and their analysis through the principles of harmonic relations towards Johannes Itten, the appearance of the composition on various textile substrates has been shown. The same artwork of author Ana Marić, a student of Undergraduate study Industrial Textile and Clothing Design at the University of Zagreb Faculty of Textile Technology, was printed using the digital printing technique on textile substrates characterized by the diversity of the surface structure and the variety of print and colour relationship depending on the type and surface of a particular textile material. Spectrophotometric measurement determines the colour values of the textured uncoloured substrates followed by printing on the same and analysing the printed surfaces using the Dino-Lite Premier AM-7013MZT digital microscope. Finally, a combination of specific colour of textiles including individual surface characteristics and the influence of textile material colouration on the appearance of the product gives authenticity to a quality textile product intended for interior decoration.*

## KEYWORDS

*Johannes Itten, harmonic colour relationships, textile substrates, digital printing, microscopic analysis*

---

## INTRODUCTION

In the field of textile design, colour as one of the dominant structural elements has a remarkable impact on the observer. The observer's reaction will not only depend on the observed colour palette, but the whole visual experience will be defined by the colour mutual interaction as well as their interaction with the textile substrate. When balance and harmony of shapes, colours and substrate/colour interaction are achieved, harmonic relationships that promote a sense of inner peace and balance are achieved [1]. In this paper, the colour interaction is analysed in two different aspects; first - in the context of colour interplay between elements of design within the artwork and their analysis according to the principles of harmonic colour ratios following the theory of J. Itten, and the second - in the context of interaction of colour and textile substrate surface (which already has a certain basic colouration) and to which the textile sample is printed by the digital printing technique.

In the latter case, the surface texture of the textile material and the reproduction of a particular sample are of great importance. In order to make a detailed analysis of the reproduction of

the Ana Marić (student) artworks by the technique of digital printing, in this paper the basic colour of four different textile substrates was measured, the surface was analysed using a digital microscope and a surface structure of a prints were also analysed by means of scanning electron microscope (SEM).

### **COLOUR INTERACTION BY THE PRINCIPLES OF HARMONY RELATIONS**

There are numerous researches on colour harmony which can generally be divided into two groups: the first is based on a proper colour scheme, they focused on systematic colour selection in the colour system (Itten (1961), Munsell (1921), Nemcsics (1993, 2007) and Ostwald (1916)); the second group studies the interplay of colours, Chevreul (1839), Chuang and Ou (2001), Goethe (1810) and Moon and Spencer (1944) claim that complementary and analogue colours by hue, chroma and lightness can result in harmonious relationship [2, 3]. Colours that in a mutual relationship induce a positive reaction are considered to be in harmony (Cho & Lee, 2005; Desmet, Overbeeke, & Tax, 2001, Jordan, 1998).

Positive emotions do not only add value to the product but also increase the possibility of better placement of products on the market [4]. What is also of particular importance and has a particular effect in colour usage in the product design, is the context in which certain colours are used; the same colour can have a completely different meaning if it is in different contexts, Wei, S. T., O., L.C., Luo, M.R., & Hutchings, J.B. (2014) [5]. Individual colour characteristics affect the emotion which particular product promotes and carry the role of element connecting the product with its function, form, and material (Jang & Kim, 2007). Colour ultimately attracts customers and assures them to buy a product. Also, the observer never perceives the colour separately from the other colours present in the space. Therefore, one of the most important aspects of colour influence on the observer is the interaction of colours and the effect of their specific relationship [6].

### **CHARACTERISTICS OF PRINTING INK AND TEXTILE SURFACE MATERIAL INTERACTION**

The main variables in the digital printing system are: printing technology, colour physics, colour and substrate interaction (textiles), pre-treatment phase and finishing. In pigment InkJet textile printing, the interaction of pigments and textile substrates is crucial in producing high-quality, well-defined images for a specific purpose. The complexity of colour interaction and media in InkJet technology was studied by Lavery and Provost (1991). In order to develop systems that improve colour characteristics and at the same time improve the quality and durability of the printed image, it is necessary to know the nature of the chemical composition of pigments and printing inks used in InkJet digital printing technology together with the way of interacting / fixing to a particular medium [7]. Unlike dyestuffs, the incorporation of pigments into the fibre is a much more complex process since

the pigments must have the shape of fine, small particles of 200 nm or less, which bond mechanically to a textile material requiring the addition of binders, cross linking agents and fixators. Therefore, an excellent and stable dispersion system is required to avoid the flocculation that causes the inkjet head nozzles to be blocked. Printing ink viscosity must be much lower, which is why it is sometimes required to pre-treat the textile material to ensure fibre and pigment proper bonding and to avoid the pigment disperse on the textile material [8].

Also, in order to control colour reproduction, it is important to know how geometrical and optical properties of a particular textile material will affect the rendering of colour. Fabric surface characteristics such as cross section or yarn orientation can affect the interaction of textile material with light which will influence the overall colour appearance of printed surface. The relationship between visual perception of surface texture and physical properties of the fabric such as geometric structure and optical properties was researched by Lee and Sato (1998, 2001), who tested the characteristics of the light reflection from different fabric constructions.

Based on their research they concluded that the reflection of light is significantly influenced and varies in the direction of the warp and the weft. In textile digital InkJet printing, the appearance of colour will be also affected by the distribution of pigment layer on the surface of a textile material. Structured, heterogeneous textile surface has a great influence on the physical part of the printing process as well as the optical and perceptual experience after printing. The basic principles of the surface roughness impact on InkJet printed substrates, but in paper digital printing technology, were studied by Oittinen and Saarelma. Their research has explained that the colour distribution in contactless printing technology such as InkJet technology, is intended for smooth surface materials since the colour diffusion on rougher surfaces causes the dye spreading out of the desired area [9].

## **EXPERIMENTAL**

### **Materials and Methods**

In this paper the specific interaction between the surface/structural characteristics of the textile substrate and the colour reproduced in digital InkJet textile printing, was analysed. The tests were carried out on the artworks of author Ana Marić, a student of Undergraduate study Industrial Textile and Clothing Design, (Figure 1), printed on textile substrates of different surface and structural characteristics.

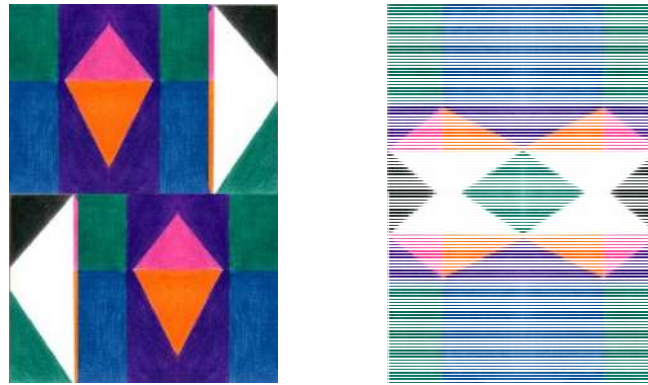

Figure 1. Artworks designed by Ana Marić

The artworks shown in Figure 1 were digitally printed by InkJet printing technique, on four textile substrates characterized with different surface and constructional characteristics. The scanned images of printed samples are shown on Figure 2 and the constructional parameters of textile samples are shown in Table 1.

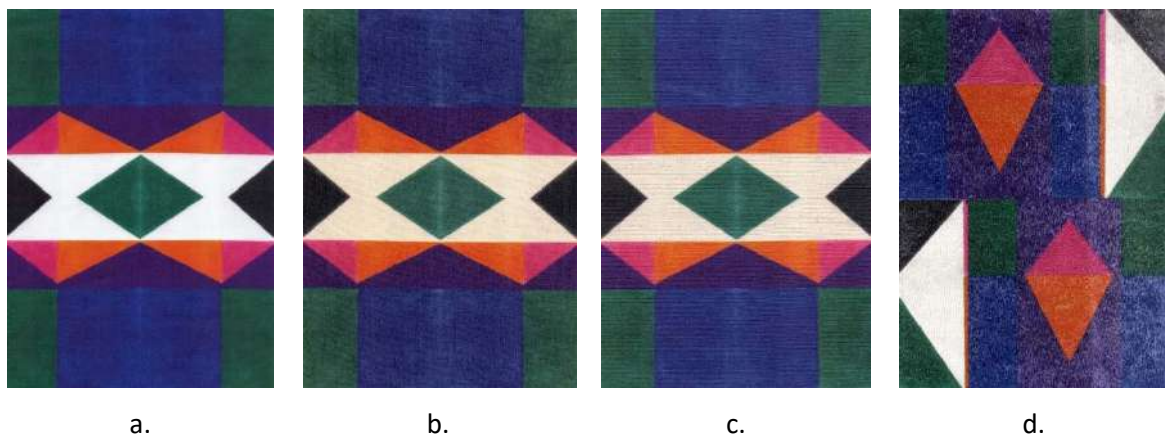

Figure 2. Scanned images of digitally printed Artworks: a – white cotton woven fabric b – raw cotton woven fabric; c – Panama raw cotton woven fabric; d – Velvet fabric

Table 1. Constructional parameter of textile samples

Sample	Type of fabric
1. 100% Cotton fabric (white)	Twill 3/1
2. 100% Cotton fabric (raw)	Twill 3/1
3. 100% Cotton fabric (raw)	Panama 2/2
4. Velvet fabric - 50% cotton, 50% PES	Base – Plain 1/1; Face - Velvet

The evaluation of basic surface colouration has been performed by spectrophotometric measurement of the textile samples, by means of remission spectrophotometer DataColour SF600+CT (DataColour Int, 41-CH), with constant instrument aperture, D65, using d/8° geometry.

The results obtained are presented as the remission characteristics as well as a\*/b\* co-ordinates and are shown in the Table 2. Afterwards, the artworks were printed directly to the textile substrates by Azon Tex Pro (10000-HR) InkJet textile printer with micro piezo printing head technology and aqueous pigment-based printing inks Azon (10000-HR). After printing, the samples were heat cured in settings 120°C for two minutes. Additionally, the digitally printed samples were analysed by scanning with Dino-Lite Premier AM-7013MZT digital microscope due to analysis of specific surface structures of the textile substrates. The results of the blue and orange colour reproduced on four different fabrics are shown in Figure 4. In final step of this work, chosen samples were analysed by scanning electron microscope FE-SEM Mira LM (Figure 6). The images of non-printed and printed surfaces were analysed and were compared to samples screen printed also with water based pigment printing paste (Figure 7). The aim was to examine in detail a specific structure and its interaction with colour as well as to analyse the distribution of polymer film that is typically structured on the surface of textile material while using the pigment printing inks and pastes. The SEM images of digitally printed samples and samples screen printed by conventional hand screen printing methods, have been compared. The results are shown on Figures 6 and 7.

## RESULTS AND DISCUSSIONS

The interaction of inks and textile substrate is one of the key parameter of colour distribution when applying InkJet technology to complex, rough surfaces such as textiles, since the technology has been developed for smooth surfaces. The surface fabric characteristics substantially impact the colour appearance, not only through the influence on the ink distribution, but also through the influence of the basic textile substrate colouration. In this paper the first step was to analyse the chosen textile samples surface structural and constructional parameters.

Constructional characteristics of textile samples are shown in Table 1. It can be seen that the samples 1, 3 and 4 are different in constructional characteristics, while the samples 1 and 2 are of the same constructional characteristics but different in pre-treatments (sample 1 was optically bleached, while the sample 2 was used in raw form, meaning that they will exhibit significant difference in basic colouration).





Figure 3. Dino-Lite microscope images of uncoloured textile samples a – white cotton woven fabric (sample 1); b – raw cotton woven fabric (sample 2); c – Panama raw cotton woven fabric (sample 3); d – Velvet fabric (sample 4)

Also, the samples were microscopic analysed by means of digital microscope Dino-Lite and were spectrophotometrically measured by means of remission spectrophotometer DataColour SF600+CT. Microscope images of four textile samples surface structures are shown in Figure 3a – 3d (samples 1 to 4) showing different surface characteristics and the inequality of the structure.

Sample 3 is more emphasised in roughness due to a specific construction characteristic. Sample 4 is a velvet sample characterised by the soft, shiny layer of cut fibres. When analysing the samples 2 and 3, apart from the emphasized surface structure, the structural density is visible. In Figure 3c (sample 3), it is visible clear distinction between warp/weft cross points and warp/weft intersecting points (the area of light transmission). In both examples, a significant interaction of colour and surface can be expected; it can be assumed that samples 3a (sample 1) and 3b (sample 2) will have better surface coverage because of the relationship between the cross points. When defining the optical properties of non-uniform surface, the loss of reflection can be expected. Due to the differences of the surface characteristics, a different proportion of scattered, reflected and absorbed light for a particular sample can be expected. Also, the light transmission will appear as well.

In further research the samples were spectrophotometrically measured in order to analyse the effect of the structured surface on remission properties of unprinted fabrics. The results are presented as the values of remission sum ( $\Sigma R$ ) and basic colour parameter values ( $L^*a^*b^*C^*h$ ) shown in Table 2 as well as the remission curves shown on Figure 4.

Table 2. Remission and basic colour parameter values of textile samples

	Sample	$\Sigma R$	$L^*$	$a^*$	$b^*$	$C^*$	$h$
1.	100% Cotton Twill Fabric (white)	2663.59	94.14	4.18	-13.78	14.40	286.86
2.	100% Cotton Twill Fabric (raw)	2086.79	86.66	1.59	13.26	13.35	83.18
3.	100% Cotton Panama (raw)	2035.4	85.39	1.84	10.67	10.83	80.19
4.	Velvet fabric - 50% cotton, 50% PES	1846.66	80.58	0.85	4.96	5.03	80.28

Optical characteristics of the textile substrates can be defined as the sum of the colour attributes and the surface structure, uniquely defined by the remissive spectrum of the textile substrate, i.e. the amount of reflected and absorbed light which is the function of both the surface structure as well as the basic surface colour. It can be seen by the results of remission sum ( $\Sigma R$ ), that there is a significant difference among the samples more emphasised for samples 1 and 4, sample 1 having the highest value of  $\Sigma R$  and sample 4 having the lowest  $\Sigma R$  value. It can be assumed that such characteristic will directly contribute to the colour depth property of further colour reproduction on given samples.

Also, for the basic colour parameters values ( $L^*a^*b^*C^*h$ ), it can be seen that spectrally the samples are mostly in yellow orange spectrum (for samples 2 to 4), except for the sample 1 having the basic colouration in blue spectrum which was expected due to the effect of optical brighteners. So, besides the surface structure characteristic, the significant influence on colour reproduction will have the basic colour characteristics of samples.

Furtherly, samples 2 to 4, regardless the significant difference in constructional and surface structure characteristics, do not exhibit the significant difference in lightness ( $L^*$ ) value. The larger difference occurred in chroma ( $C^*$ ) value, which is not so influenced by the surface structure as it is influenced by the basic colour of samples, more emphasised for sample 4 having greyish basic colouration. This is the reason of obtaining the lowest  $\Sigma R$  value for sample 4, as well. As for the smooth and shiny surface structure of sample 4 it would be expected that it will exhibit the higher  $\Sigma R$ , but due to a specific, achromatic greyish basic colour, the both chroma and  $\Sigma R$  values are the lowest.

Spectral remission curves confirm significant differences in colour properties regarding the characteristics of the substrate basic colouration (Figure 4).

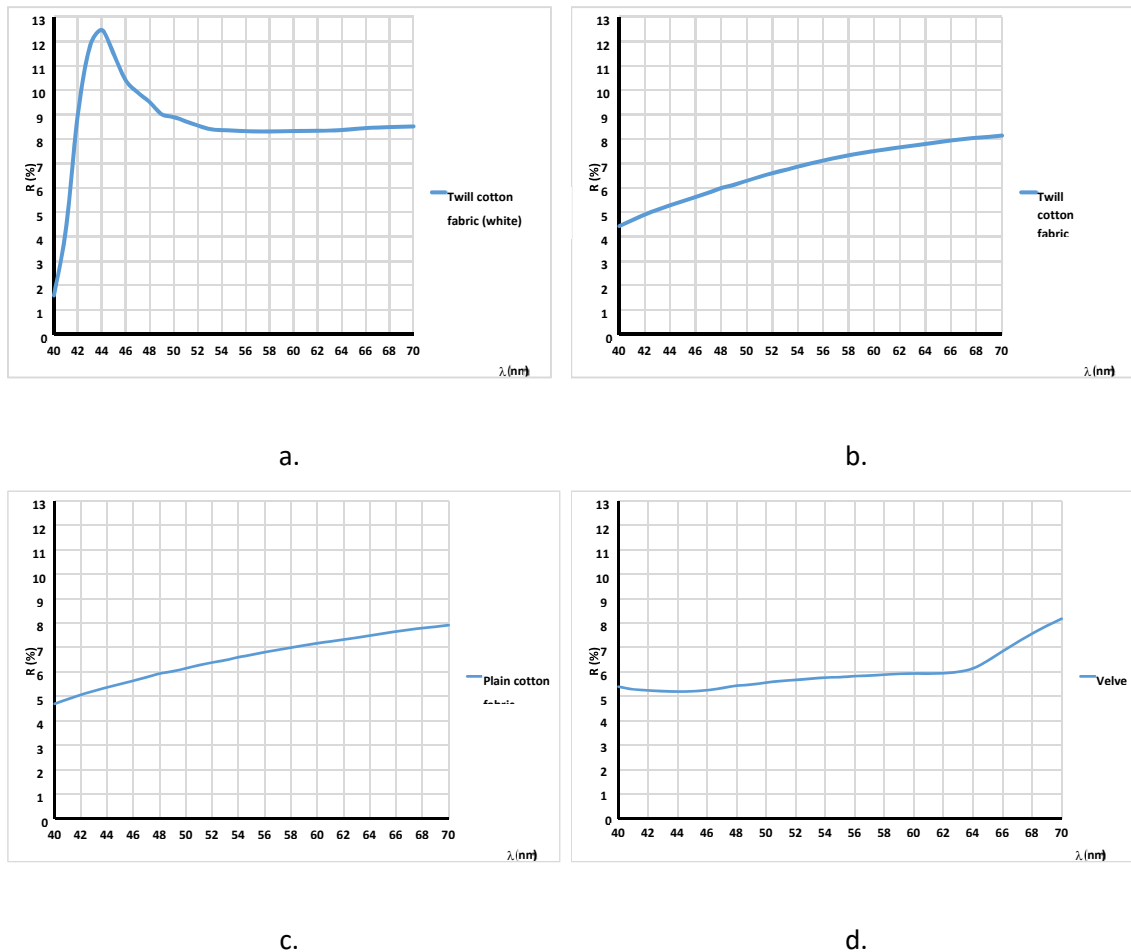

Figure 4. Remission curves of textile samples: a – white cotton woven fabric (sample 1); b – raw cotton woven fabric (sample 2); c – Panama raw cotton woven fabric (sample 3); d – Velvet fabric (sample 4)

It can be seen that, regardless the significant difference in constructional and surface characteristics as well as in basic colouration, samples 2 to 4 (figure 4b to 4d) do not exhibit significant difference in overall spectral characteristics, and their remission curves that define spectral characteristic of one surface, are quite uniform showing equal reflection of all parts of the spectrum, which is characteristic for the achromatic colours. The remission curve for sample 1 (Figure 4a) shows typical behaviour of optically whitened textile surface that has the emphasized reflectance in blue region. As for the surface structural characteristics, it can be said that the remission curves do not express the difference in surface structural characteristics of tested samples, and that the difference and influence of surface structure on reflectance – absorbance – transmission relationship is not quite presented by the remission curves.

After the remission and spectral characteristics analysis of textile samples, in further work the artworks were printed on tested textiles as described in experimental part. Figure 5 shows images scanned with Dino-Lite microscope - the interaction of two different colours, blue and orange, presented on four different fabrics (samples 1 to 4).

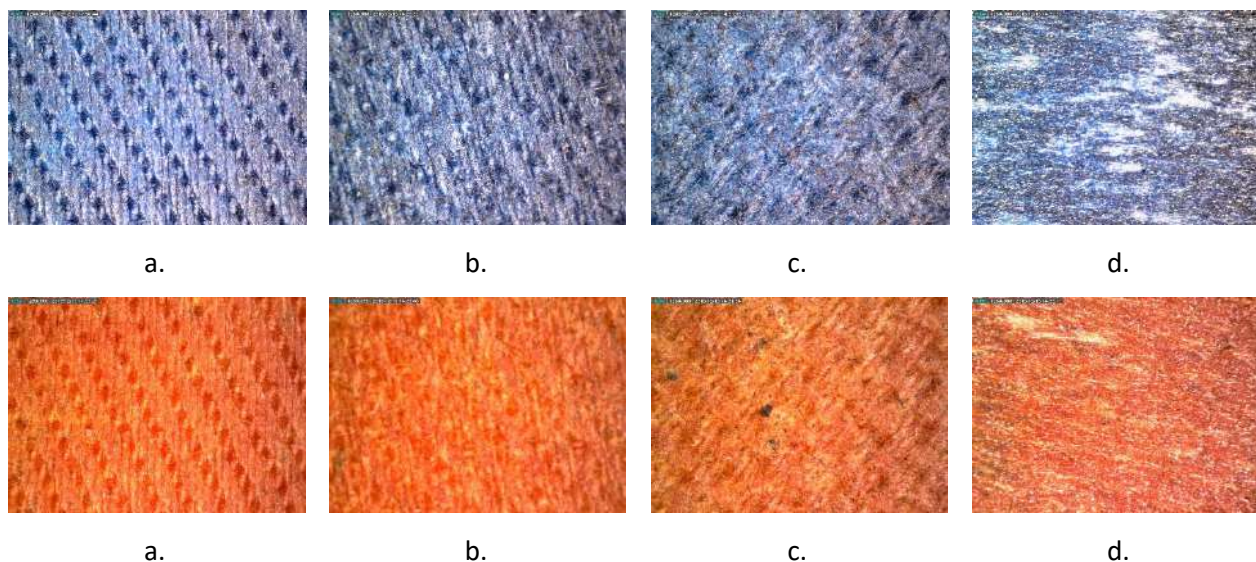

Figure 5. Dino-Lite microscope images of digitally printed textile samples; blue and orange colour is shown: a – white cotton woven fabric (sample 1); b – raw cotton woven fabric (sample 2); c – Panama raw cotton woven fabric (sample 3); d – Velvet fabric (sample 4)

Despite the same fabric construction, the difference between digitally printed samples 5a (sample 1 - Cotton Twill Fabric, white) and 5b (sample 2 - 100% Cotton Twill Fabric, raw) is evident. Although there is a difference in basic colouration between those two samples, the more significant influence on colour rendering has the difference in samples surface characteristic, which is more uniform for sample 1 (5a). Those differences are caused by pre-treatment phase of samples in which the sample 1 (5a) was optically bleached while sample 2 (5b) was used in raw condition. Although the surfaces were not analysed by means of Scanning Electron Microscope (SEM), it is to be assumed that a larger number of striking fibres will be present on the surface of raw sample (sample 2 (5b)) as well as various solid impurities commonly removed from cotton yarns in pre-treatment and bleaching stages.

That is the reason why the twill structure of sample 5a (sample 1) is perfectly visible including cross points as well as intersection points unlike the sample 5b (sample 2) where the structure characteristics are not clearly visible. On Figure 5c, the printed sample 3 is shown and is characterized by lower yarn density causing the more emphasized wrap/weft intersection points (Figure 3). It is to be assumed that such structure will result in certain image information loss as well as the lower image reproduction quality since, because the number and size of intersection points will strongly influence the colour rendering and the reproduction of image details. Sample 4 presented on Figure 5d is specified with velvet shiny surface structure characterized with layer of cut fibres. Uniform colour coverage can be observed, and the parts of the image that appear to be non-coloured are the results of reflection from the glossy surface during microscopy.

As for the colour characteristics, certain difference in reproduction can be seen between orange and blue colour. It can be seen that the textile surface structures are more emphasized and visible for blue colour, although the characteristics and composition of printing inks used for colour reproduction are exactly the same. Even more, for colour reproduction in digital textile InkJet printing, the four basic process colours were used – magenta, yellow, cyan and black, while all the other colours and shades are produced by their mixing. However, since the InkJet technology has been developed for smooth, uniform, homogeneous surfaces, there are still numerous problems while applying this technology to structured, heterogeneous surfaces such as textile. Due to a complex interaction of specific surface structural properties of textile substrate which are the key variables for reproducing digital colour, requirements on printing inks composition as well as requirements of technology of ink droplet formation, there are numerous barriers which require solution finding researches. One of such barriers and problems is optimal mixing of process colours that have been designed for smooth, homogeneous surfaces such as paper, which allows proper mixing in regular droplet shape and precise position. Such mixing is hard to achieve on structured, fibrous surface such as textile. It can be clearly seen on Figure 5, presenting the prints in two colours - orange and blue which are in InkJet printing achieved by mixing two process colours, how certain irregularities occurred in mixing process. The areas of cyan and magenta process colours are visible in reproduction of blue colour while the areas of magenta and yellow are visible in reproduction of orange colour. Such irregularities in mixing process will certainly affect the quality of reproduced colour and image details.

In the final step of this analysis, digitally printed sample 1 (Cotton Twill Fabric, white) was compared to a sample of a same fabric screen printed by means of analogue manual screen printing technique, using the standard water based pigment printing paste. Since the digital InkJet textile printing device is also using the water based pigment inks, the idea was to analyse the formation of polymer layer formed on surface of textile material, which mechanically binds the pigment to a textile material, created in a process of digital printing and in a process of conventional screen printing. One of the advantages of digital pigment printing is the formation of a more uniform, thinner polymeric layer on the surface of the textile material, thus achieving a smaller difference between printed and unprinted areas allowing the printed image to become a natural part of a textile surface structure, not covering it with thick polymer layer.

The analysis was performed by means of scanning electron microscope FE-SEM Mira LM and the results are shown on Figures 6 and 7. Figure 6 shows the images of non-printed sample 1 (figures 6a and 6b) which are compared to digitally printed sample 1 (figures 7a and 7b) and screen printed samples (figures 7c and 7d).

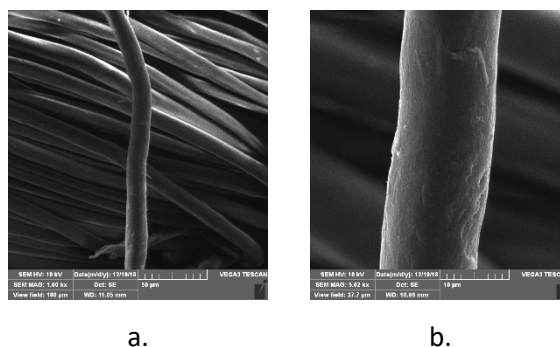

Figure 6. SEM images of textile samples used in experimental: a – non-printed white cotton woven fabric- twill (SEM magnification x1000); b – non-printed white cotton woven fabric- twill (SEM magnification 5.02 kx);

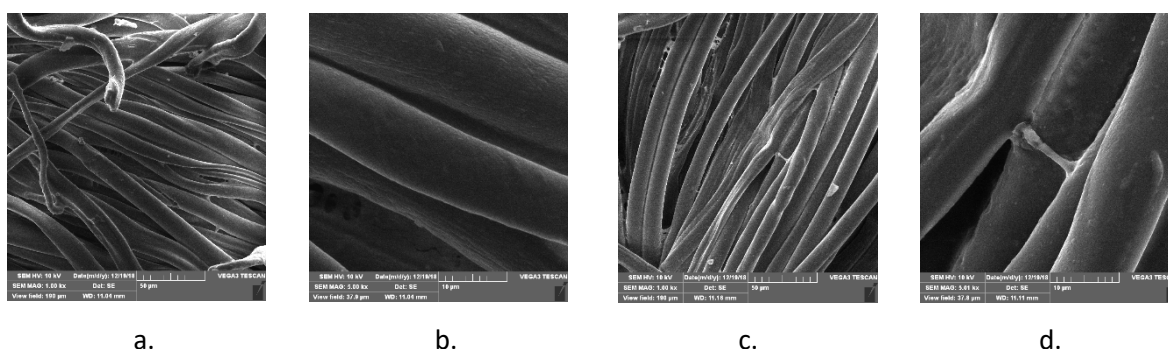

Figure 7. SEM images of textile samples used in experimental: a – digitally printed white cotton woven fabric- twill (SEM magnification x1000); b – digitally printed white cotton woven fabric- twill (SEM magnification 5.02 kx); c – screen printed white cotton woven fabric- twill (SEM magnification x1000); d – screen printed white cotton woven fabric- twill (SEM magnification 5.02 kx)

By comparing the images 7a/b and 7c/d, it can be seen that the digital printing process will result in formation of a thin, uniform polymer film covering the surface of the substrate by smooth encirclement of the fibres, while the inter-fibre spaces remain relatively accentuated thus following the natural structure and constructional characteristics of the textile surface. The polymer film formed in screen printing is thicker, less uniform and the inter-fiber spaces are more covered also with polymer film. This would consequently increase the available surface area of the substrate increasing the possibility of larger amount of pigment to be bonded with the substrate, but it also significantly changes the natural surface appearance intervening into a tactile and physical - mechanical properties of a textile materials, which is one of the disadvantages of pigment printing.

## CONCLUSIONS

When designing a textile product using printing techniques, several aspects have a major role in the context of using the colour: first, it is important to achieve a harmonic colour combination when creating a certain textile pattern or artwork for specific purpose and second – to produce the product

with identical colour appearance according to the specific textile technique meaning to assure the satisfactory colour reproduction throughout the variety of different textile surface structures and by applying different techniques of reproduction. In this paper, the colour interaction is analysed in two different aspects; first - in the context of colour interplay between elements of design within the artwork and their analysis according to the principles of harmonic colour ratios following the theory of J. Itten, and the second - in the context of interaction of colour and textile substrate surface (which already has a certain basic colouration) and to which the textile sample is printed by the digital printing technique. In textile printing, different surfaces of textile substrates together with its construction and texture characteristics, printed under same conditions and with the same dyes may cause different final appearance. Therefore, it can be confirmed that apart from the textile material basic colouration, the roughness due to a specific construction characteristic, emphasized surface structure and the structural density, cross points and intersecting points can affect the final appearance. It was shown that the surface structure will influence the final colour appearance from physical aspect influencing directly the relationship of reflectance, absorbance and transmittance from the textile material surface, and also from the aspect of polymer layer formation as the carrier of the pigments as well as influencing the mixing of process CMYK colours.

## REFERENCES

- [1] Glogar, M. I.: *Primjena računalnog vrednovanja boje u definiranju harmonijskih odnosa među bojama u dizajnu uzorkovanog tekstila*, Tekstil 61 (1-6) 74-83 (2012.)
- [2] Wei, S. T., Ou, L. C., Luo, M. R., & Hutchings, J. B.: *Package Design: Colour Harmony and Consumer Expectations*, International Journal of Design, 8(1), 109-126 (2014)
- [3] Itten, J.: *The Elements of Colour*, (John Wiley & Sons (Ed.)), published by John Wiley & Sons Inc., Germany: ISBN:0471-28929-9 (1987)
- [4] Kenneth, E. Burchett: *Colour Harmony*, Art Department, University of Central Arkansas, Conway, AR 72035, Volume 27, Number 1 (2002)
- [5] Wei, S. T., Ou, L. C., Luo, M. R., & Hutchings, J. B.: *Package Design: Colour Harmony and Consumer Expectations*, International Journal of Design, 8(1), 109-126 (2014)
- [6] Na, N., & Suk, H. J.: *The emotional characteristics of white for applications of product colour design*, International Journal of Design, 8(2), 61-70. (2014)
- [7] Lavery, A. and Provost, J. Zeneca Specialties: *Colour-Media Interactions in Ink Jet Printing*, Recent Progress in Ink Jet Technologies II, Chapter 6, Ink and Media, IS&T Manchester, UK (1999)

- [8] Work, R. A.: *Pigment Printing's Role in Ink Jet Textile Printing*, Recent Progress in Ink Jet Technologies II, Chapter 8, Textile Printing, III, New Business Development Manager DuPont Ink Jet Enterprise Wilmington, DE 19880-0030 USA (1999)
- [9] BAE, JIHYUN: *Colour in Ink-Jet Printing: Influence of Structural and Optical Characteristics of Textiles* (Under the direction of Dr. Traci A.M. Lamarand Dr. Trevor J. Little)



Clothing technology & engineering

**TZG**

# CREATEING 3D GARMENT PATTERN FROM ADAPTIVE DIGITAL MODELLING OF HUMAN SPINE FOR PERSONS WITH SPINAL DISABILITY

**Sarah MOSLEH<sup>1\*</sup>, Pascal BRUNIAUX<sup>1</sup>, Guillaume TARTARE<sup>1</sup>**

<sup>1\*</sup>ENSAIT/GEMTEX, Roubaix, France University of Lille, Villeneuve-d'Ascq, France, \*email: sara.mosleh@ensait.fr

---

## ABSTRACT

*In this paper we introduce a novel method for augmenting the spinal 3D model in real-time scene during diagnosis of various spinal deformities especially scoliosis. Morphology of the spine can be adapted to the torso actual shape with the aid of new digital 3D technologies that is proposed to design garment from shape of body based on 3D model of spine. This model could be able to customize for each patient according to EOS imaging (a medical imaging system whose aim is to provide frontal and lateral radiography images) especially in this study scoliosis. To achieving this model Lectra design concept is used.*

## KEYWORDS

*Scoliosis, 3D model, adaptive model, morphology*

---

## INTRODUCTION

Thorough understanding of spine anatomy is essential not only for diagnostic interpretation but also safe and effective performance of spine procedures. Moreover, visualizing spine anatomy in three dimensions is essential, allowing one to recognize and interpret overlapping structures on fluoroscopy. Existing educational material on spine procedures contains excellent illustrations, many utilizing 3-dimensional (3D) models. Additionally, there are numerous videos online demonstrating various spine procedures using 3D animations and actual patients [1],[2].

The method we are considering, which merges the two previous methods, is to set up an adaptive skeleton that would be integrated into the morphology of the scanned person. This skeleton would then be connected to this morphology in order to make it evolve over time.

## LITERATURE REVIEW

First of all, we should know about the structure of skeleton and also the shape of bones. The spine is strong enough to support the weight of the upper body, yet flexible enough to move. It's composed of 24 individual vertebrae – hard bones that give the spine its strength. The vertebrae have flexible cartilaginous discs between them that allow the spine to move as a single line. Each plane

moves only a little, but they add up to a lot. Like a string of beads. Every little movement contributes to a graceful curve.

There are 4 sections to the spine. The Cervical section of the neck consists of 7 vertebrae. The Thoracic section of the ribcage has 12 vertebrae, one for each rib. The Lumbar section of the lower back has 5 vertebrae. The fourth section is technically considered as 2 separate sections, but I'm going to combine them – the sacrum and coccyx, which is the tailbone. Let's call this the sacral section.

The sections give the spine a 4-arch curve. If the spine were a straight line, it would be strong, but rigid. This 4 arch curve gives better flexibility for shock absorption and aids in balance. And it's the framework for the posture of the body.

The cervical curve is the least curvy – it's almost a straight line. But, it does have a very subtle forward curve. The thoracic curve is longest, and curvier than the cervical section. It curves backward and aligns with the shape of the ribcage.

## **FUNCTIONALITIES AND MORPHOLOGY OF VERTEBRAE**

Spine modelling requires a thorough analysis of the different functionalities of the vertebrae which strongly influence the morphology of each of them. The goal is to understand why it is divided into three distinct groups (lumbar, dorsal and cervical vertebrae) which generate three types of morphology. But, given that some features could be common, would it be possible to find a basic generic model on which we could graft the morphological specificities of each group. Thus, we would have a generic model that could be derived in three morphological variants.

Figure 1 schematizes the relationship between the spinal cord and the nerve roots coming out on either side of the spine. This connexion towards the whole nervous system acts on the morphology of the vertebrae by excavations. Similarly, the stacking and adjustment of each vertebra (Figure 2) on top of each other contributes strongly to their morphology by prominences leading to the upper and lower facets representing the contact zones of the joint process. Other contact zones are located at the level of the intervertebral discs whose role is to ensure the damping of the spinal column against heavy loads and to bring the mobility or 3D deformation of the spine. The modelling of the spine has to take into account all these morphological constraints imposed by these different functional, mobility and stability criteria [3].

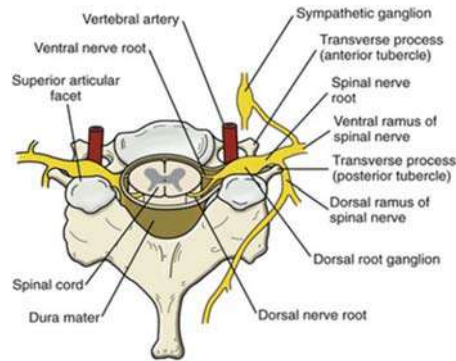

Figure1. Relationship among the neural tissues, components of vertebra and the vertebral artery

### 3D ADAPTIVE VERTEBRAE MODEL

The modelling process of a lumbar vertebra begins with the creation of its vertebral body (Figure 2). A first extruded circle at the height of the vertebra creates the two upper and lower vertebral plates and the volume of the vertebral body. Another eccentric circle at the first is partially used to define the spinal canal (blue shape). The diameters of these two circles are proportional to their extrusion height in order to adjust their dimension to the lumbar vertebrae number [4].

Thus, the volume of the vertebra is managed by its height, which is itself defined proportionally to the total length of the spine according to an anthropometric report that we will specify later.

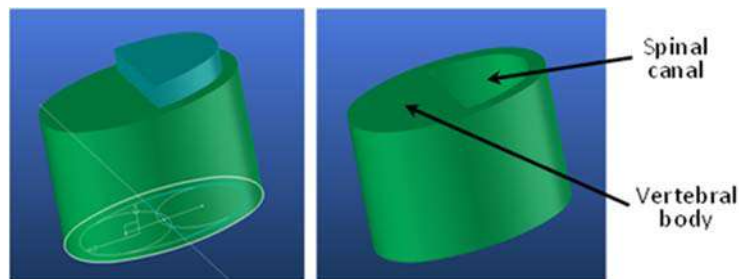

Figure 2. Vertebral body and spinal canal creation

An important element in the overall dimensioning of the vertebra is the spinous process with a more or less curved and long shape (Figure 3). To do this, we have created a guide curve that manages both the length and curvature of the spinous process.

Finally, the Figure 4.a shows our final generic model representing three-dimensionally controllable lumbar vertebrae by the different green dimensions (Figure 4.b). These dimensions are in relation with each other to have only one parameter allowing this model to evolve from the lumbar vertebra L5 to the lumbar vertebra L1 (Figure 4.c).

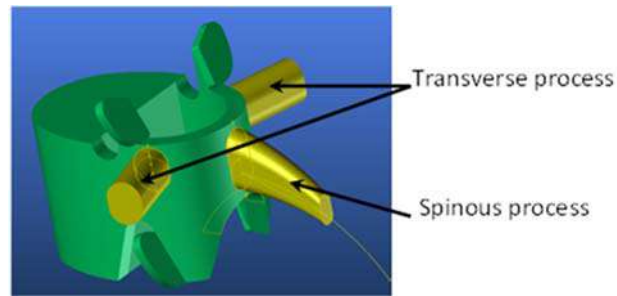

Figure 3. Transverse and spinal process creation

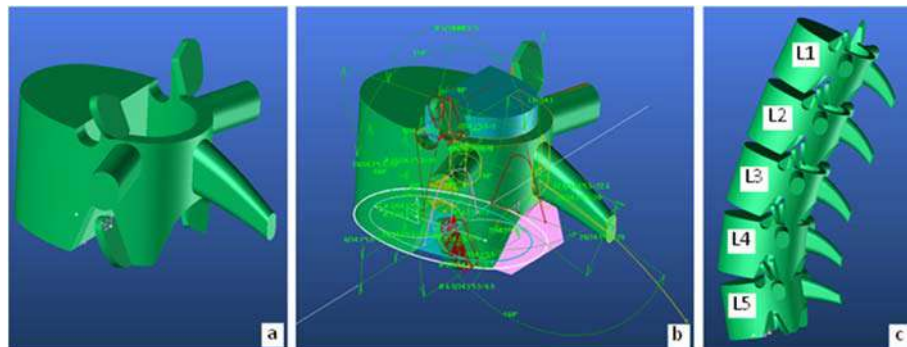

Figure 4. Adaptive vertebra model (a) (b), lumbar vertebrae L1 to L5 (c)

### Dorsal vertebrae model

The dorsal vertebra model is very similar to the lumbar vertebra model. Apart from the size of the vertebrae, which gradually reduce from the D12 to the D1, they differ morphologically from the lumbar vertebrae in their spinous process, straighter for the D12, more curved and shorter for the D11, more marked and imposing in length for the following ones (D10 to D1) (Figure 5.a). To do this, we act on the curvature of the guideline that gives this curved shape [5]. Another difference is in the transverse process which is more short and slightly closer to the spinous process (Figure 5.b).

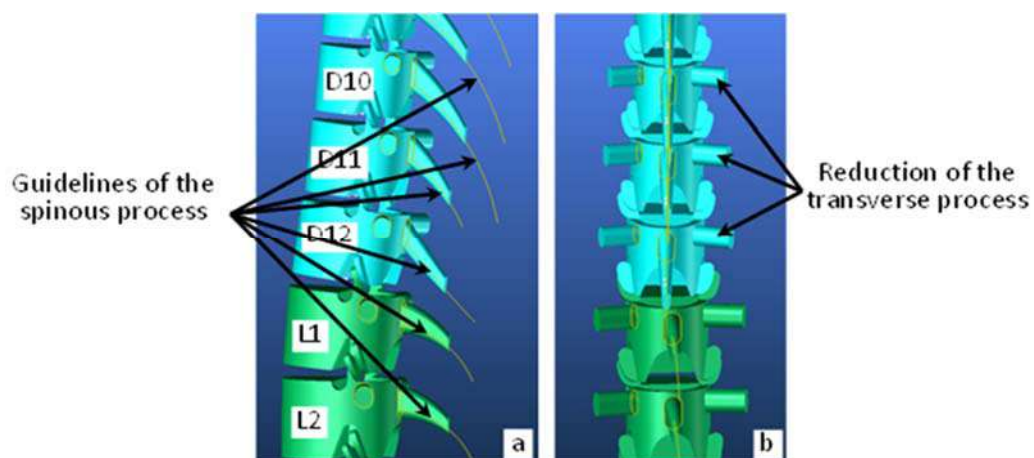

Figure 5. Dorsal vertebrae model

### C7 Cervical vertebrae model

C7 is very atypical because it is at the interface between the dorsal and cervical vertebrae, which imposes two types of contact morphology with the upper and lower intervertebral discs (Figure 6.a). Starting from the D1 dorsal vertebra model, we added a purple block and inclined the upper part of the new transverse process to obtain a suitable connection with the C6 vertebra (Figure 6.b). The transverse process was modified in his posterior part to get a better seating of the vertebrae on each other, and completed by anterior and posterior tubercles to define the transverse foramen. The spinous process has been adapted given its very pronounced presence.

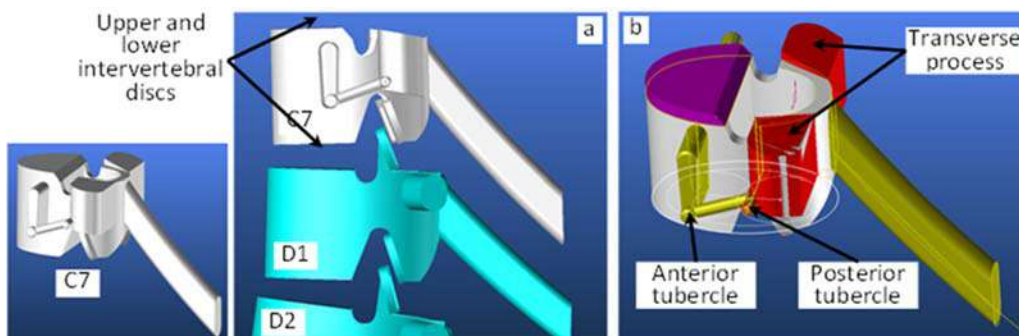

Figure 6. C7 cervical vertebra model

### C6, C5, C4, C3 Cervical vertebrae model

As we mentioned earlier, the C6, C5, C4, C3 cervical vertebrae are very similar (Figure 7.a). Their vertebral body is generally smaller while their spinal canal is larger, managed by the two lower white circles (Figure 7.b). The pedicles have been adjusted thanks to the basic red circles and inclined red lines, and repositioned due to the decrease of the vertebral body. The superior and inferior surfaces of the vertebral bodies are not as flat as those of most other vertebrae but have been curved with the purple and yellow blocks. The transverse process has been adjusted to create a new articular process which defines a continuous articular pillar (Figure 7.a). The spinous process of C6 has been reduced if we compare it with the C7, more reduce and cursed for the C5, C4, and C3.

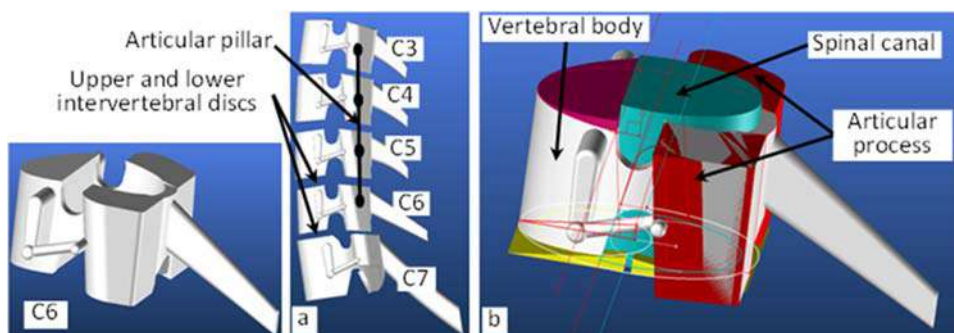

Figure 7. C6, C5, C4, C3 cervical vertebra model

## FIRST RESULT

Figure 8.a.b shows that the generic model we have created from the shape and specificities of the lumbar vertebrae is close to reality. We could criticize that the position of the articular processes of our model is farthest back to the posterior part. But this is not a problem because the joint process can slide and follow the upper curve of the laminae of posterior arch. This model which we slightly modified to adapt it to the dorsal vertebrae follows relatively well the shape these last. We can notice on the Figure 8.c.d that the stacking of D6, D7 D8 is well respected. A critique could be made on the shape of the spinous process which tends strongly downwards in the real case.

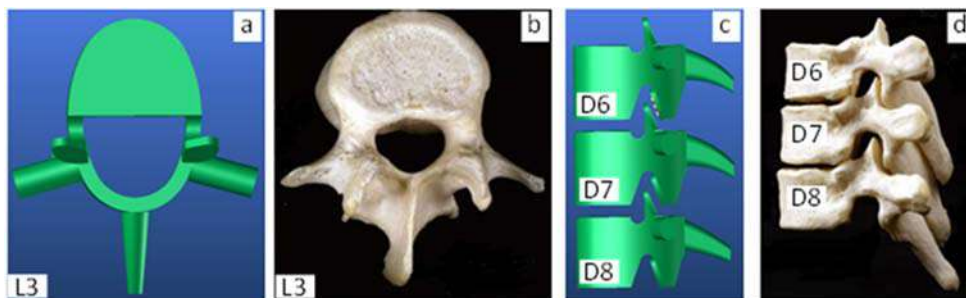

Figure 8. Virtual and real model of lumbar and dorsal vertebrae

As already mentioned, the cervical vertebrae have a very specific articular process which leads to a strong overlapping in each other. The real world of the stacking of the 7 cervical vertebrae in figure 10 shows that we are fairly close to reality (Figure 9.a). Each specific model integrates well all the morphological specificities of their category. C7 has a very important spinous process, as well as a transverse process very different from that of the generic lumbar and dorsal vertebrae model (Figure 9.b.c). The C6, C5, C4, C3, C4, C3 have a slightly smaller vertebral body which leads to a more important spinal process (Figure 9.d.e). The articular process is higher than C7 (Figure 9.a). The C2 is very imposing following the integration of the two articular processes designed laterally on the vertebral body (Figure 9.f.g). The dens are perfectly positioned in the axis of the vertebral body. The transverse processes follow correctly the external morphology of the vertebral body. The whole gives a compact overall shape respecting the morphology of the C2. The spinous process is more pronounced at its tip but needs to be reduced by adjusting the length of the director curve as for the dorsal vertebrae. The modelling of the C1 by a ring is very representative of it (Figure 9.h.i). The addition and proper sizing of the joint process gives it its overall shape. The two transversal processes perfectly complete the whole.

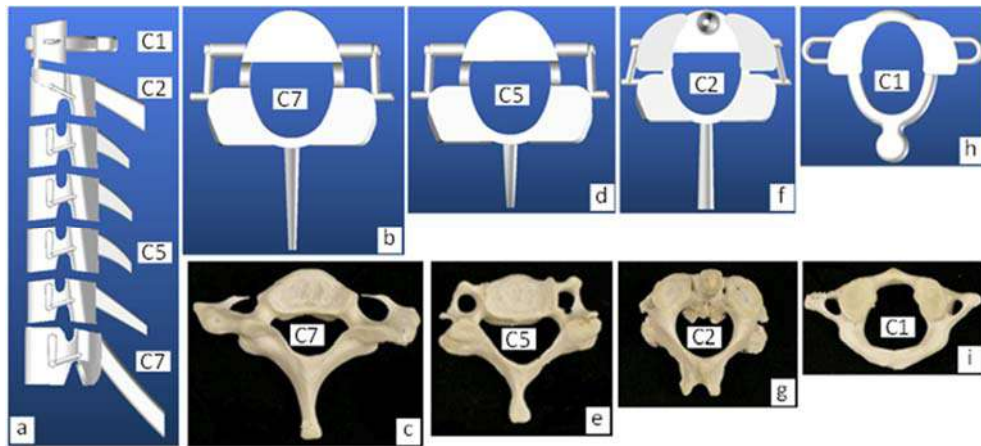

Figure 9. Virtual and real model of cervical vertebrae

### 3D MODEL OF SPINE IN 3D SPACE

#### *3D models of vertebra connected*

As we have already noticed, the spinal column is a very precise stack of vertebrae evolving according to a defined curve in a 3D space. This curve characterizes the morphology of the person, in particular his posture. In order to describe the 3D path of this curve, we chose to characterize it in the two main planes, the sagittal plane and the coronal plane.

Our model segments this path in 24 portions represented by a set of line  $D_{tn}$  on which will align the 24 vertebrae of the spine.  $t$  represents the type of vertebra (C: cervical, D: dorsal, L: lumbar) and  $n$  the number of the vertebra in its category. Each line is defined by polar coordinates  $(l_{tn}, \alpha_{tn}, \beta_{tn})$  in its own reference located at the lower end of the line.  $l_{tn}$  represents the length of the line equal to the height of the vertebra and its upper intervertebral disc.  $\alpha_{tn}$ ,  $\beta_{tn}$  respectively represents the two polar angles of the lines projected on the sagittal and coronal planes. It is important to note that the rising dependency of vertebrae from their stacking is created when creating straight lines one after the other in the rising direction of the spine. This dependence is obtained by creating the coordinate system of the next (upper) vertebra at the end of the right of the previous (lower) vertebra.

The total length  $L_s$  of the spine is the only parameter to give the model for parameterizing the length  $l_{tn}$  of each vertebra/disk. We use the vertebral ratios of Table 1 resulting from the works of A. Frostell et al. [6],[7] to automatically calculate the length values  $l_{tn}$ .



Table 1. Relative lengths of human vertebral bony segments

Segment	Percentage of spine	Cumulative percentage of spine
C1	3.2	3.2
C2	3.2	6.4
C3	2.8	9.1
C4	2.7	11.9
C5	2.7	14.6
C6	2.6	17.2
C7	3.1	20.2
D1	3.4	23.6
D2	3.7	27.3
D3	3.4	31.3
D4	3.9	34.9
D5	3.9	38.8
D6	4.2	42.9
D7	4.3	47.3
D8	4.5	51.7
D9	4.6	56.3
D10	4.8	61.2
D11	5.1	66.2
D12	5.4	71.7
L1	5.7	77.3
L2	5.8	83.1
L3	5.7	88.8
L4	5.7	94.6
L5	5.5	100

In order to take into account the 3D deformation of the spine in atypical cases of scoliosis, each vertebra can rotate by an angle  $\gamma_{tn}$  on the axis of the line assigned to it.

## SECOND RESULT

The first tests were carried out with a spine perfectly aligned vertically with different lengths  $L_t$  of this one. We have gone from a spine with a length  $L_t=750\text{mm}$  to a length  $L_t=550\text{mm}$ . These values are very representative of reality. The results of the Figure 10 show that all vertebrae realign perfectly with each other while reducing their volume. The first part of the table represents the height of each vertebra based on the ratios in the Table 1.

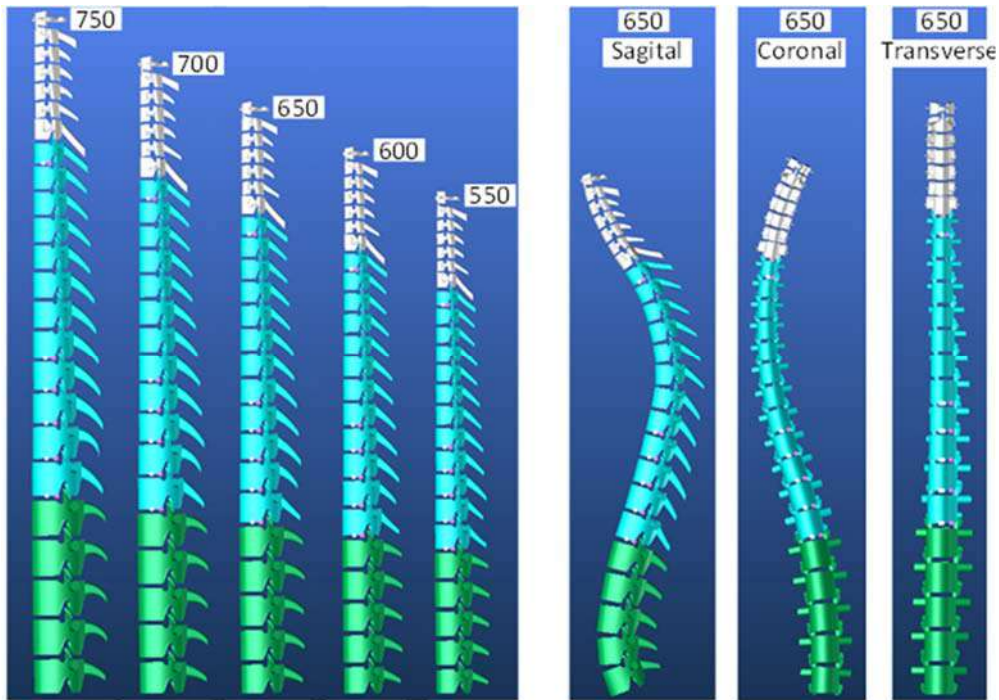

Figure 10. Straight spines with different values of Lt, spine deformation in the 3 planes

The 3 other tests show separately the deformation of the spinal column in the 3 characteristic planes: sagittal, coronal and transverse [8]. These deformations were carried out with the same length of spine  $L_t = 750\text{mm}$  in order to show its impact on the overall height of the person following the first two deformations, the third not affecting this height. This parametric independence will be very useful to represent later all types of scoliosis deformations. The second part of the table represents the rotation angle of each vertebra in the sagittal plane. The third part of the table represents the angle of rotation of each vertebra in the coronal plane. The last one represents the rotation of each vertebra in his transverse plane, i.e. its rotation on itself [9].

Table 2. Values of  $l_{tn}$  for the different values of  $L_t$ , Values of the deformation angles  $\alpha_{tn}$ ,  $\beta_{tn}$ ,  $\gamma_{tn}$  in sagittal, coronal, transverse planes

Segment	H <sub>750</sub>	H <sub>700</sub>	H <sub>650</sub>	H <sub>600</sub>	H <sub>550</sub>	Sagittal	H <sub>650</sub>	Coronal	H <sub>650</sub>	Transverse	H <sub>650</sub>
$l_{C1}$	18	16.8	15.6	14.4	13.2	$\alpha_{C1}$	10	$\beta_{C1}$	-26	$\gamma_{C1}$	15
$l_{C2}$	18.75	17.5	16.25	15	13.75	$\alpha_{C2}$	15	$\beta_{C2}$	-23	$\gamma_{C2}$	12
$l_{C3}$	19.5	18.2	16.9	15.6	14.3	$\alpha_{C3}$	20	$\beta_{C3}$	-20	$\gamma_{C3}$	9
$l_{C4}$	20.25	18.9	17.55	16.2	14.85	$\alpha_{C4}$	25	$\beta_{C4}$	-17	$\gamma_{C4}$	6
$l_{C5}$	20.25	18.9	17.55	16.2	14.85	$\alpha_{C5}$	28	$\beta_{C5}$	-14	$\gamma_{C5}$	3
$l_{C6}$	19,5	18.2	16.9	15.6	14.3	$\alpha_{C6}$	30	$\beta_{C6}$	-11	$\gamma_{C6}$	0
$l_{C7}$	23.25	21.7	20.15	18.6	17.05	$\alpha_{C7}$	36	$\beta_{C7}$	-8	$\gamma_{C7}$	-3
$l_{D1}$	25.5	23.8	22.1	20.4	18.7	$\alpha_{D1}$	33	$\beta_{D1}$	-6	$\gamma_{D1}$	-6
$l_{D2}$	27.75	15.9	24.05	22.2	20.35	$\alpha_{D2}$	27	$\beta_{D2}$	-3	$\gamma_{D2}$	-9
$l_{D3}$	27.75	15.9	24.05	22.2	20.35	$\alpha_{D3}$	17	$\beta_{D3}$	0	$\gamma_{D3}$	-12
$l_{D4}$	29.25	27.3	25.35	23.4	21.45	$\alpha_{D4}$	14	$\beta_{D4}$	3	$\gamma_{D4}$	-15
$l_{D5}$	29.25	27.3	25.35	23.4	21.45	$\alpha_{D5}$	8	$\beta_{D5}$	6	$\gamma_{D5}$	-18
$l_{D6}$	31.5	29.4	27.3	25.2	23.1	$\alpha_{D6}$	1	$\beta_{D6}$	9	$\gamma_{D6}$	-21
$l_{D7}$	32.25	30.1	27.95	25.8	23.65	$\alpha_{D7}$	-10	$\beta_{D7}$	12	$\gamma_{D7}$	-24
$l_{D8}$	33.75	31.5	29.25	27	24.75	$\alpha_{D8}$	-13	$\beta_{D8}$	15	$\gamma_{D8}$	-27
$l_{D9}$	34.5	32.2	29.9	27.6	25.3	$\alpha_{D9}$	-14	$\beta_{D9}$	18	$\gamma_{D9}$	-24
$l_{D10}$	36	33.6	31.2	28.8	26.4	$\alpha_{D10}$	-15	$\beta_{D10}$	21	$\gamma_{D10}$	-21
$l_{D11}$	38.25	35.7	33.15	30.6	28.05	$\alpha_{D11}$	-16	$\beta_{D11}$	18	$\gamma_{D11}$	-18
$l_{D12}$	40.5	37.8	35.1	32.4	29.7	$\alpha_{D12}$	-18	$\beta_{D12}$	15	$\gamma_{D12}$	-15
$l_{L1}$	42.75	39.9	37.05	34.2	31.35	$\alpha_{L1}$	-15	$\beta_{L1}$	12	$\gamma_{L1}$	-12
$l_{L2}$	43.5	40.6	37.7	34.8	31.9	$\alpha_{L2}$	-11	$\beta_{L2}$	9	$\gamma_{L2}$	-9
$l_{L3}$	42.75	39.9	37.05	34.2	31.35	$\alpha_{L3}$	-8	$\beta_{L3}$	6	$\gamma_{L3}$	-6
$l_{L4}$	42.75	39.9	37.05	34.2	31.35	$\alpha_{L4}$	4	$\beta_{L4}$	3	$\gamma_{L4}$	-3
$l_{L5}$	42.25	38.5	35.75	33	30.25	$\alpha_{L5}$	20	$\beta_{L5}$	0	$\gamma_{L5}$	0

## CONCLUSIONS

This study has illustrated a cost effective method for constructing a 3D model of a complicated anatomical shape such as the human vertebrae and has shown that such a method, while not as accurate as active scanning approaches, is accurate enough for several applications including visualisation and for constructing statistical shape models. As far as we are aware, no such public repository for human vertebrae currently exists. Additional investigations are required across different user groups to further validate the generated data and determine its usefulness across applications. This model dose not completely match to real, however this issue dose not important because we don't want to propose this model to study about vertebra and skeleton, the main aim was having an adaptive model that we could change it according to data of each patient than recognized shape of body from skeleton.

## **Acknowledgement**

We would like to thank the collaboration with the medical staff of the Private Hospital of Villeneuve-d'Ascq in France- Ramsay image of real spinal deformations of atypical morphologies is taken by 3D EOS.

## **REFERENCES**

- [1] J. Cramer, E. Quigley, T. Hutchins, and L. Shah., "Educational Material for 3D Visualization of Spine Procedures: Methods for Creation and Dissemination," vol. 30, no. 3, pp. 296–300, 2017.
- [2] H. Bennani, B. J. McCane, and Cornwall, "Three Dimensional (3D) Lumbar Vertebrae Data Set.," *Data Sci. J.*, vol. 15, no. 9, pp. 1–15, 2016.
- [3] Panel A. Saria, R. Gamse, J. Petermann, J. A. Fischer, and E. Theodorsson-Norheim J. M. Lundberg, "Simultaneous release of several tachykinins and calcitonin gene-related peptide from rat spinal cord.," *Neurosci. Lett.*, vol. 63, no. 3, pp. 310–314, 1986.
- [4] Hattori T, S. H, I. M, N. Y, Y. H, and S. K., "In vivo three-dimensional segmental analysis of adolescent idiopathic scoliosis.," *Eur Spine J.*, vol. 20, no. 10, pp. 1745–1750, 2011.
- [5] Q. J *et al.*, "Comparison of the aorta impingement risks between thoracolumbar/lumbar curves with different convexities in adolescent idiopathic scoliosis: a computed tomography study," *Eur Spine J*, vol. 21, no. 10, pp. 2043–2049, 2012.
- [6] Frostell, R. Hakim, E. Thelin, Mattsson, and Svensson, "A review of the segmental diameter of the healthy human spinal cord," *Front. Neurol.*, vol. 7, no. 23, 2016.
- [7] Y. Hayashi *et al.*, "Measurement of vertebral body dimensions of the thoracic and lumbar spines of 242 healthy women," *J. Bone Miner. Metab.*, vol. 16, no. 1, pp. 27–33, 1998.
- [8] D. T. A. Witkin and M. Kass, "Constraints on deformable models: Recovering 3D shape and nonridged motion.," *Artif. Intell. Med.*, 1988.
- [9] V. T, P. F, and L. B, "A review of methods for quantitative evaluation of axial vertebral rotation.," *Eur Spine J*, vol. 18, no. 8, pp. 1079–1090, 2009.

# INNOVATIVE IDEAS BY STUDENTS AT THE FACULTY OF TEXTILE TECHNOLOGY IN THE FIELD OF SMART CLOTHING

**Snježana FIRŠT ROGALE<sup>1\*</sup>, Dubravko ROGALE<sup>1</sup>**

<sup>1</sup>University of Zagreb, Faculty of Textile Technology, Prilaz baruna Filipovića 28a, 10000 Zagreb, Croatia, \*email: sfrogale@ttf

---

## ABSTRACT

*The scientific team, led by Professor Dubravko Rogale, develops a completely new kind of clothing called intelligent clothing with adaptive thermal insulation properties for a long time. They have developed several functional prototypes to date. With the development of innovative solutions in the field of intelligent clothing, the team also develops measuring systems for textile technology.*

*Students of Faculty of textile Technology are involved in scientific research work and innovative development of new kind of clothing. Through the development of their student's projects, designed and created interesting prototypes. In this paper is presented the e-shirt, the e-bike jacket, the smart bag with built-in protection against theft of content, the smart cap for heart rate monitoring, the intelligent clothing item for supervising the work of forest workers and the triboelectric generator.*

## KEYWORDS

*Innovation, student projects, smart clothing, measurement systems*

---

## INTRODUCTION

At the meeting of the Thematic Expert Group, TEG no 6 Smart Textiles & Clothing" within the European Technology Platform for the future of Textiles and Clothing organized by EURATEX in January 2006, 37 experts coming from all the European countries accepted the definition and characteristics of the term intelligent clothing. The experts agreed that three sets of instruments should be integrated into an article of clothing: sensors for measuring and information input which collect input information, processing unit for interpreting input information and making decisions (microcomputers, microprocessors or microcontrollers with accompanying programs) and output actuators for adapting an article of clothing and provide output information. This definition is in accordance with investigations performed in the sector of developing intelligent clothing and publications in the course of 15 previous years at the Department of Clothing Technology of the Faculty of Textile Technology of the University of Zagreb. The scientific team, led by Professor Dubravko Rogale, made several types of air-filled chambers with changeable thermal insulation properties, either by activating combinations of chambers or by changing chamber thickness. In addition, they developed own original and complete sensors, microcomputer system and actuators based on microcompressors, valves and other elements of micropneumatics. They also created own algorithms of intelligent behaviour and the software controlling the operation of the intelligent article of clothing and the function of the rational

consumption of electrical resources of battery supply. Within this development, we painstakingly made progress and developed an overall functioning architecture on the basis of which the first prototypes of the first generation were created and patented. Based on the shortcomings of the first generation a significant modification was developed, and a completely different approach was made to intelligent clothing with adaptive thermal protection which is considered to be second and third generations [1].

Intelligent clothing and measurement systems have been developed at the Department of Clothing Technology of the Faculty of Textile Technology of the University of Zagreb was presented at exhibitions of inventions, innovations and patents in order to valorise the results achieved at international level, and the following awards were won, Figure 1:

- 2017 - Gold Medal, Kaohsiung International Invention Exhibition 2017, Taiwan (for Multi-purpose differential thermal conductivitymeter for textile composites and clothing),
- 2017 - Silver medal, INVENTION EXPO 2017, Tokyo (for the development of intelligent clothing),
- 2017- Gold medal, 42. Inova / 13. Budi uzor (for Multifunctional differential thermal conductivitymeter for textile composites and clothing),
- 2017 - Grand Prix 2nd Prize, 42nd Inova / 13. Budi uzor (for Multifunctional differential thermal conductivity meter for textile composites and clothing),
- 2016 - Gold medal, Kaohsiung International Invention Exhibition 2016, Taiwan (for the development of intelligent clothing),
- 2016 - Award for Best Innovation in Applied Science, 41st Inova / 12. Budi uzor 2016 (for an Integrated Measuring Device for Human Body Physical Parameters in Exact Assessment of Heat Comfort Clothes),
- 2016. - Special Award for Best Scientific Commercialization of Smart Specialization awarded by Tera Tehnopolis and Croatian Association of Entrepreneurs Entrepreneurs, 41. Inova / 12 Budi uzor 2016 (for an Integrated Measuring Device for Human Body Physical Parameters in Exact Assessment of Heat Comfort Clothes),
- 2016. - Gold medal, 41. Inova / 12. Budi uzor 2016 (for an Integrated Measuring Device for Human Body Physical Parameters in Exact Assessment of Heat Comfort Clothes)2016 - Acknowledgment of the Croatian Community of Technical Culture,
- 2016 - Dean Award, University of Zagreb Faculty of Textile Technology2015 - E.S.PENKALA Award for Best Zagreb`s Innovation, Association of Inventors, Zagreb (for intelligent clothing),
- 2015 - Gold medal, 40. Inova/11. Budi uzor (for intelligent clothing),
- 2015 - Award INOVA - the best Croatian exhibitor, 40. Inova/11. Budi uzor (for intelligent

clothing),

- 2015 - Gold medal, 13. international exhibition of inventions ARCA Zagreb (for intelligent clothing),
- 2015 - Gold medal, 13. international exhibition of inventions ARCA Zagreb (for thermal manikin),
- 2015- Silver medal, Malaysia Technology EXPO (for intelligent clothing),
- 2015 - Gold medal 7th European exhibition of creativity and innovation EUROINVENT (for intelligent clothing),
- 2014 - Grand Prix for the best Industrial Design, 17. Moscow International Salon of Inventions and Innovation Technologies Archimedes (for intelligent clothing),
- 2014 - Gold medal, 17. Moscow International Salon of Inventions and Innovation Technologies Archimedes (for intelligent clothing),
- 2014 - Silver medal, 17. Moscow International Salon of Inventions and Innovation Technologies Archimedes (for thermal manikin),
- 2014 - Golden medal, 6th European exhibition of creativity and innovation EUROINVENT (for intelligent clothing),
- 2014 - Special Prize, University of Sibij Lucian Blaga, as a sign of honor, recognition and appreciation of the scientific creativity and originality to inventors, 6th European exhibition of creativity and innovation, EUROINVENT (for intelligent clothing),
- 2014 - Silver medal, 6th European exhibition of creativity and innovation EUROINVENT (for thermal manikin),
- 2014 - Silver medal, Taipei International Invention Show (for thermal manikin),
- 2014 - Gold Medal – Award of Merit, 29th INPEX - Invention & New Product Exposition, Pittsburgh (for intelligent clothing),
- 2014 - Humanitarian Award, 29th INPEX - Invention & New Product Exposition, Pittsburgh (for intelligent clothing),
- 2014 - Spanish Delegation Award, 29th INPEX - Invention & New Product Exposition, Pittsburgh (for intelligent clothing),
- 2014 - Gold medal, 14th British Invention Show, London (for intelligent clothing),
- 2014 - Gold medal, 39. Inova/10. Budi uzor (for intelligent clothing),
- 2014 - INOVA - The best innovation of the science, 39. Inova/10. Budi uzor (for intelligent clothing),
- 2014 - Special Award, Romanian Inventors Forum EUROINVENT, 39. Inova/10. Budi uzor (for intelligent clothing),

- 2014 -Silver medal, Kaohsiung International Invention Exhibition, Taiwan (for thermal manikin).



Figure 1. Several awards for intelligent clothing and thermal manikin

As part of the bilateral project Development of smart clothing for people with dementia (funded by the Ministry of Science and Education) of the aforementioned scientific team and team at the Faculty of Mechanical Engineering of University in Maribor, smart clothes for demented persons has been developed. The goal of developing smart clothing for people with dementia is to provide comfortable clothing with active character, that is, smart clothing that will be equipped with modern sensors for the installation of clothing and the benefits of information technology. Such a clothes could help and guide the user in everyday activities, therapies, maintenance of everyday personal hygiene, appearance editing, and / or automatic tracking of body functions, as well as user location information to the dental care caregiver.

### INNOVATIVE IDEAS BY STUDENTS

The aforementioned scientific team involved students, scientific research and innovative work through was developed of their masters thesis. Students produced very interesting prototypes: the e-shirt, the e-bike jacket, the smart bag with built-in protection against theft of content, the smart cap for heart rate monitoring, the intelligent clothing item for supervising the work of forest workers and the triboelectric generator. The smart pyjamas for those suffering from apneas is just in the final stage



of development. The awards for student innovative projects are presented in Table 1 and Figure 2.

Table 1. The awards for student innovative projects

Student / Mentor	Innovation	Award	Invention show
Ljubica Radišić / Snježana Firšt Rogale	The e - shirt	Silver medal award	44 <sup>th</sup> International Invention show INOVA 2018, Zagreb
Martina Peck Tijeglič / Snježana Firšt Rogale	The e - bike cycling jacket	Gold medal award & the best innovation in sports and recreation	44 <sup>th</sup> International Invention show INOVA 2018, Zagreb
Marina Mesić, Matej Mesić / Snježana Firšt Rogale	The smart bag with built – in protection against theft of content	Gold medal award	44 <sup>th</sup> International Invention show INOVA 2018, Zagreb
Marija Veldić / Snježana Firšt Rogale	The smart cap for heart rate monitoring	Gold medal award	44 <sup>th</sup> International Invention show INOVA 2018, Zagreb
Damir Begić / Dubravko Rogale	The intelligent clothing item for supervising the work of forest workers	Gold medal award  Bronze medal award	44 <sup>th</sup> International Invention show INOVA 2018, Zagreb  10 <sup>th</sup> International Innovation Fair and 3 <sup>rd</sup> World Innovation Forum (IEI & WIIF 2018), China
Juro Živičnjak / Dubravko Rogale	The triboelectric generator	Gold medal award & the best innovation in science  Silver medal award & special award	44 <sup>th</sup> International Invention show INOVA 2018, Zagreb  KIDE 2018, Taiwan

Including a designer in the development of e-shirts, Figure 3, apart from technical functionality, the significance of aesthetic components has increased. This is achieved in a way that the shirt has a so called *Cyber looku*. In this way, the world of fashion tries to bridge the gap between new technologies and modes. The LEDs, integrated into the T-shirt, are powered by batteries and are based on the algorithm in the microcontroller, located inside the T-shirt [2].

The e-Bike Cycling jacket includes the diodes at the front and back. The front are placed on the chest area and they are lighted all the time while driving, after switching on the power supply located in the front pocket while the rear side illuminates when the button is pressed on the left or right side of the sleeve depending on whether the bicycle is turned to the left or right. In this way, the bicycle driver is visible from both the front and the rear, offering greater safety in traffic, which was the

purpose of making this prototype [3].

The smart bag with built-in protection against theft of content embedded microcontroller that is via Bluetooth module connected to the bracelet. The microcontroller is a flexible electrically conductive coupling element connected to the upper and lower part of the magnet clasp on the backpack, which opens the circuit. Circuit breaks information is sent via a Bluetooth module to the microcontroller embedded in the bracelet. The bracelet with light and sensory stimuli signals that the backpack is open. Based on the control algorithm, the LED and vibration motor are activated. The smart cap for monitoring heart rate is embedded with a sensor and microprocessor, which efficiently monitor the wearers heart rate using the sensors light intensity. The information received is then transmitted through Bluetooth to a mobile application on the wearers smart phone. It can be used for monitoring the health status of different groups of people: from children to the elderly, from patients to professional athletes and soldiers [4].

The design of the smart cap for monitoring heart rate, Figure 4, was designed to demonstrate the advancement of technology in the textile industry as well as the multidisciplinary intelligence of smart clothing. The cap is embedded with a sensor and microprocessor which efficiently monitor the wearers heart rate using the sensors light intensity. The information received is then transmitted through Bluetooth to a mobile application on the wearers smart phone. It can be used for monitoring the health status of different groups of people: from children to the elderly, from patients to professional athletes and soldiers [5].

The intelligent clothing for monitoring of forest workers work was designed for labourers who use a chainsaw and it can be classified as a type of intelligent clothing because it has a built-in sensor, a microcomputer with an algorithm of intelligent behavioural and actuators. This intelligent article of clothing has two primary functions: oversight over the labourer and the labourer's protection in the case of a workplace injury. The oversight element is based on the observation of the environmental sounds the worker produces through the use of a chainsaw, but also a vibration sensor that logs the vibrations caused by the chainsaw's engine in order to reduce mistakes induces by random surrounding noise. This makes it possible to track the effectiveness of the labourer over the course of his working day. A built in GPS system tracks the movement of the worker, which is then displayed on a map of the terrain (forest) the labourer is operating on. The protection of the worker is based on the built in vibration sensor and gyroscopic body position trackers. The built in microcomputer tracks the movements of the labourer as well as the position of his body [6].



Figure 2. The awards for student innovative projects

Should an injury occur, the labourer will change the way he moves and stands and the microcomputer will, based on this data, conclude that an injury has occurred and then activate the executive device (a cell phone or radio transmitter) which will then forward a request for help to rescuers, along with GPS data regarding the position of the worker. The microphone and miniature sound device can then further facilitate communication if needed.



Figure 3. e-shirt

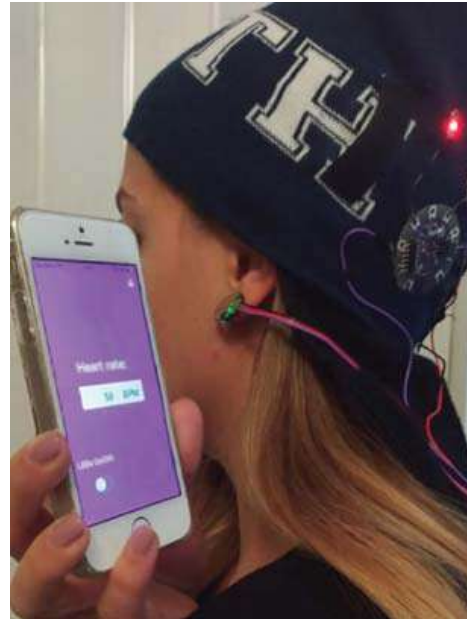

Figure 4. Smart cap for heart rate monitoring

The triboelectric generator is a device that has the ability to store a static charge that can occur in many different ways, and one of them is by rubbing two materials, figure 5 [7].



Figure 5. The triboelectric generator

The materials used to loosen the static charge are textile materials, used for making garments. The mode of operation will be demonstrated on the device that consists of two parts and one of them is mechanical part, which simulates rubbing layers of material in garments. The mechanical part of the device is made of the lower, static sample carrier, which also has a copper contact surface for draining the resulting electrical charge. Then, the upper, movable sample carrier, which also has a copper contact surface, bearing of the sample loads and the lever to which the linear movement of the carrier is realized. Both carriers have contacts for connection to the triboelectric generator.

The triboelectric generator is the second part of the device, that displays the amount of generated charge and has the ability to change the generator capacity to 1, 20 or 200 nC and discharge it. The device has confirmed the ability and cost effectiveness of installing triboelectric generators in clothing items as a renewable source of electricity.

## CONCLUSIONS

A project *Development and thermal properties of intelligent clothing* funded by the Croatian Science Foundation is underway. The miniaturization of electronic and pneumatic components for the development of new prototypes of intelligent clothing will be used on this project. Alternative ways of supplementing battery resources (flexible photovoltaic panels, power conversion adapters from other sources, etc.) will also be used. Five doctoral theses within the project will be produced. Therefore, it is expected that doctoral students will continue to demonstrate their innovation.

## Acknowledgements

This paper was written within the Research project HRZZ IP-2018-01-6363: Development and thermal properties of intelligent clothing funded by the Croatian Science Foundation.

## REFERENCES

- [1] Firšt Rogale S, Rogale D, Dragčević Z, Nikolić G, Bartoš M. Technical Systems in Intelligent Clothing with Active Thermal Protection, Dragčević Z. editor. Proceedings of the 3<sup>rd</sup> ITC&DC, 8-11 October 2006; Dubrovnik, Croatia. Zagreb: Faculty of Textile Technology, University of Zagreb; 2006. p. 413-419
- [2] Radišić Lj. The Elements of e-clothing Design, master thesis, 2017, Faculty of Textile Technology, University of Zagreb
- [3] Peck-Tijeglić M. Designing e-jacket for bicyclist, master thesis, 2018, Faculty of Textile Technology, University of Zagreb
- [4] Mesić M. Bag with embedded anti-theft protection, master thesis, 2018, Faculty of Textile

Technology, University of Zagreb

- [5] Veldić M. Designing smart clothing elements for heart rate monitors, master thesis, 2018, Faculty of Textile Technology, University of Zagreb
- [6] Begić D. Smart article of clothing for supervising the work of forest workers, master thesis, 2018, Faculty of Textile Technology, University of Zagreb
- [7] Živičnjak J. The appearance and usability of static charge of garments, master thesis, 2018, Faculty of Textile Technology, University of Zagreb

# INVESTIGATIONS OF BODY PROPORTIONS OF STUDENTS FOOTBALL PLAYERS

**Darko UJEVIĆ<sup>1</sup>, Blaženka BRLOBAŠIĆ ŠAJATOVIĆ<sup>1\*</sup>, Ksenija DOLEŽAL<sup>1</sup>, Bin YU<sup>2</sup>, Yunchu YANG<sup>3</sup>, Feichao ZHU<sup>2</sup>**

<sup>1</sup>University of Zagreb Faculty of Textile Technology, Prilaz baruna Filipovića 28a, 10000 Zagreb, Croatia, \*email: blazenka.brlobasic@ttf.hr

<sup>2</sup>Silk Institute, College of Materials and Textiles

<sup>3</sup>School of Fashion Design & Engineering, Zhejiang Sci-Tech University, Hangzhou 310018, China

---

## ABSTRACT

*Within the framework of the bilateral project of the Republic of Croatia and the People's Republic of China, the research of the body proportions of students who practice football. Research is being conducted in the Republic of Croatia (University of Zagreb and Zadar) and the People's Republic of China (Zhejiang Sci Tech University from Hangzhou). The measurements are carried out by educated measurers within the research teams of the two countries. The results of the research show a statistically significant increase middle leg girth value of football players.*

## KEYWORDS

*anthropometric measurements, Croatia, China, football*

---

## INTRODUCTION

Anthropometry as one of the anthropology methods deals with measuring the human body and finding the relationship in the size of its individual parts. In the production of fashion wear and footwear, anthropometric measurements are used in the field of construction and modeling, and they are obtained by anthropometric measurements of a representative sample of a certain population [1,2].

Garment manufacturing and garment fit to the body physique are the subjects of continuous research. Monitoring changes and insights into the actual amounts of body dimensions of a particular population open up numerous possibilities of influence on the manufacture and design of clothing [3,4].

One of the biggest problems with the selection of clothing is dissatisfaction with garment fit. Anthropometric studies of collecting data on body measurements of a representative population sample take a lot of time and data such as fit of different garment types is not available. Garment patterns were made according to standard. However, such a garment does not fit the whole population. For example, in the trained population, there are deviations in some body measurements compared to the standard size clothing system causing garment unfit.

## **Anthropometric characteristics of football players**

Previous research related to anthropometry engaged in team sports is based on the analysis of athletes in the group as a whole and on the analysis of the player's position, comparison of the trained and untrained population.

It is evident from an overview of the available literature on the morphological characteristics of athletes or anthropometric characteristics of football players that these subjects are studied by a number of authors, and that there is a significant number of scientific papers. It can be concluded that the anthropometric characteristics of football players are used to establish football player performance, and changes in anthropometric characteristics under the influence of football game are studied [5,6]. By reviewing the literature it can be concluded that there are differences in anthropometric characteristics of football players with regard to player position.

By studying anthropometric characteristics between the trained and untrained population it was found out that the body height of football players did not differ significantly from the average male population of the same age, but lower body mass and lower value of fat tissue were observed. By comparing the results of body height with earlier research data an increase in the average body height of football players was noticed. Differences between the trained and untrained population in some other anthropometric measurements, such as an increase in the shoulder width of football players as well as leg circumferences, were observed [7,8].

## **EXPERIMENTAL**

### **Materials and Methods**

The study included a total of 204 men aged between 18 and 26. For the purposes of this study, the conventional method of anthropometric measurements was used to determine anthropometric sizes for young men (football players and untrained population) in accordance with standards ISO 3636 and ISO 8559. 102 football players had an average playing experience of 10.7 years and 102 untreated test subjects of the general population. Body measurements determined using the conventional method of anthropometric measurements were determined using anthropometric instruments. The measurements were carried out in two cities (Zagreb, Zadar).

## **RESULTS AND DISCUSSIONS**

Only a part of the results of the research carried out within the bilateral project are presented in this paper. The results of anthropometric measurements in the Zagreb and Zadar areas, as well as



the comparison of the body measurements of trained and untreated population, are presented table 1.

Table 1. Basic parameters of the distribution of body measurements of football players and untrained population

Body measurements (cm)	Football players(cm)			Untrained population (cm)			Difference	t	p
	X ± SD	Min	Max	X ± SD	Min	Max			
Body height	180.3±5.64	166.	193.0	179.4±5.2	170.0	190.0	0.87	1.437	0.152
Chest girth	92.8±5.42	81.0	108.0	92.7±8.03	74.0	113.5	0.19	0.250	0.803
Waist girth	79.1±6.11	68.0	104.0	81.5±9.32	61.0	110.0	-2.46	-2.809	0.005
Hip girth	97.5±4.94	84.0	112.0	98.3±7.07	86.0	119.5	-0.78	-1.152	0.250
Trouser length	111.9±5.84	90.0	125.0	110.0±5.7	90.0	120.0	1.88	2.916	0.004
Crotch length	83.8±4.31	72.5	98.5	83.1±4.45	69.0	96.0	0.73	1.437	0.136
Buttock depth	26.0±4.42	17.0	35.0	25.3±4.52	15.5	35.0	0.69	1.395	0.164
Waist height	110±5.87	97.0	125.0	108.9±4.9	96.0	119.0	1.01	1.677	0.094
Hip height	91.0±4.55	79.5	102.5	90.5±4.69	75.0	105.3	0.51	0.989	0.324
Knee height	52.2±3.20	42.0	59.8	51.9±3.69	42.2	63.0	0.38	0.987	0.324
Ankle joint	5.1±0.74	3.4	7.0	5.4±0.85	3.5	7.5	-0.34	-3.835	<0.001
Hip depth	21.0±1.87	17.0	26.0	20.9±4.31	12.0	33.0	0.07	0.199	0.842
Total buttock	73.2±6.76	57.0	92.0	72.7±9.62	48.0	97.0	0.47	0.513	0.608
Inner thigh	33.6±3.39	25.0	42.0	31.9±4.14	18.5	42.0	1.70	4.049	<0.001
Upper thigh	57.1±3.86	47.0	69.0	55.0±5.66	42.0	74.0	2.16	4.008	<0.001
circumference									
Middle leg girth	52.1±3.35	45.0	62.0	47.1±5.51	45.0	62.0	5.02	9.910	<0.001
Circumference	34.8±2.07	30.0	43.0	34.9±2.55	26.5	43.0	-0.04	-0.156	0.876
under the knee									
Knee girth	38.5±2.0	34.0	46.0	38.3±3.06	33.0	51.5	0.22	0.779	0.436
Lower leg	37.3±2.66	28.0	44.0	36.7±3.40	27.0	49.0	0.63	1.868	0.063

The results showed that footballers are slightly higher, but not significantly, the chest girth is almost equal to that of untrained subjects, and the hip girth is somewhat smaller. The biggest and significant statistical difference is in the upper thigh circumference, mid-thigh circumference, whose value is higher in football players and in the waist girth which is lower in football players.

Table 2 shows the values of the main body measurements (body height, chest girth, waist girth, hip girth, middle leg girth), measured in Zagreb and Zadar. Comparative analysis shows that the values of the above mentioned body measurements are higher in Zadar.

Table 2. Basic parameters of the distribution of body measurements of football players

Body measurements (cm)	Zagreb				Zadar			
	Mean	Min	Max	St. deviation	Mean	Min	Max	St. deviation
Body height	180.3.	166	193	4.63	181.1	167	190	5.37
Chest girth	98.8	81	108	5.07	94.23	81	108	6.4
Waist girth	79.1	68	104	5.05	81.59	70	104	8.24
Hip girth	97.5	84	112	5.38	98.83	76	112	6.24
Middle leg girth	51.1	45	62	6.69	52	45	63	9.97

## CONCLUSIONS

Further research will focus on comparing physical measures between Croatia and China, and improving the size of clothing system in scientific and professional terms. Based on the results obtained by the standard method, the differences and differences between the sports population within the age of 18 and 30 will be determined and the physical difference between the examined population between Croatia and China will be determined. Knowledge and monitoring of anthropometric parameters of body proportions, and in particular the dynamics of sports population, is an important indicator of health trends, clothing development, footwear and clothing size system.

## Acknowledgements

Results shown in this paper were supported by the bilateral Croatian –China project “Anthropometric measurements for woven and nonwoven clothing „.

## REFERENCES

- [1] Ujević D. et al. Hrvatski antropometrijski sustav : Podloga za nove hrvatske norme za veličinu odjeće i obuće. , Zagreb: Tekstilno-tehnološki fakultet Sveučilišta u Zagrebu; 2006.
- [2] Brlobašić Šajatović, B. Istraživanje tjelesnih proporcija trenirane i netrenirane populacije kao čimbenika u postupcima konstruiranja odjeće. [dissertation]. Zagreb: Sveučilište u Zagrebu Tekstilno – tehnološki fakultet; 2014.
- [3] Ashdown, S.P. Sizing in Clothing: Development effective sizing system for ready-to-wear clothing, Woodhead Publishing in association with The Textile Institute. Cambridge; 2007.
- [4] Ujević, D. et al.. Theoretical aspects and application of croatian anthropometric system, Zagreb: Tekstilno- tehnološki fakultet Sveučilišta u Zagrebu; 2010.p. 73-81
- [5] Ujević, D. et al. Hrvatski antropometrijski sustav – Fakultetski priručnik. Zagreb: Tekstilno-tehnološki fakultet Sveučilišta u Zagrebu; 2006.

- [6] Ujević, D., Szivovicza, L., Dimec. Prikaz istraživanja i usporedbe sustava odjevnih veličina. Tekstil 52; 2003.p 611-620
- [7] Chun – Yoon, Jasper, C.R. Garment sizing system – An International comparison. International Journal of Clothing Science and Technology 5; 1993. p 28-37
- [8] Aldrich, W. History of sizing system and ready-to-wear garment. Sizing in Clothing, Developing effective sizing for ready-to-wear clothing. England. The Textile Institut. Woodhead Publishing Limited; 2007. p 1-56
- [9] HRN ISO 3635:2008 – Označivanje veličine odjeće – Definicije i postupak mjerenja tijela (ISO 3635:1981)
- [10] HRN ISO 8559:2012 – Oblikovanje odjevnih predmeta antropometrijska istraživanja – Tjelesne mjere (ISO 8559:1989)
- [11] HRN EN 13402 (1-3 dio) : 2008, Označivanje veličina odjeće – 1. dio: Nazivi, definicije i postupak mjerenja tijela (ISO 3635:1981, MOD; EN 13402-1:2001); 2. dio: Primarne i sekundarne dimenzije (EN 13402-2:2002) i 3. dio: Mjere i intervali (EN 13402-3:2004)

# PERFORMANCE OF DIVING SUITS FROM THE ASPECT OF THERMAL COMFORT

Vesna Marija POTOČIĆ MATKOVIĆ<sup>1\*</sup>, Ivana SALOPEK ČUBRIĆ<sup>1</sup>, Goran ČUBRIĆ<sup>1</sup>

<sup>1</sup>University of Zagreb Faculty of Textile Technology, Prilaz baruna Filipovića 28a, 10000 Zagreb, Croatia, \*email: marija.potocic@ttf.hr

---

## ABSTRACT

*Wetsuits are designed to protect divers from underwater environment and to reduce the thermal shock that may happen during the stay in the cold water. When the body is immersed, the heat transfer by conduction occurs between the and surrounding water. In comparison to the air, the thermal conductivity of water is 25 times greater. Water also has ability to absorb body heat approximately 3500 times greater than air of the same volume. In the water, the heat transfer trough convection is caused by currents or due to movements through the water. It also needs to be pointed out that the heat transfer by convection is significantly higher in windy conditions and when waves are intensive. Wetsuits are typically worn where the temperature of water is in the range 10-25°C. They provide thermal protection that depends of the level of fit, meaning that suit that is too loose on the body may not be thermally efficient. Such suits have some additional limitations among which should be pointed out the fact that water can enter the suit and increase the level of thermal discomfort.*

*In this investigation, IR thermography is used to observe the changes in skin temperature of divers wearing neoprene diving suit immersed in sea water. For the measurement is used thermal camera FLIR E5. In the paper are discussed the regional changes of the skin temperatures due to immersion. The outcomes of research will facilitate the process of designing wetsuits in order to increase/decrease thermal insulation in the zones that are identified and finally to maintain optimal thermal comfort.*

## KEYWORDS

*Thermography, wetsuit, thermal comfort, performance*

---

## STRUCTURE AND PROPERTIES OF NEOPRENE MATERIALS

A wetsuit is a garment worn by divers, surfers, windsurfers, canoeists, and others engaged in water sports. Considering the characteristics of diving suits, it must be soft, elastic, of high tensile strength, strong tear resistance to protect the divers from being hurt by coral and harmful animals. The material must have strong thermal insulation properties, abrasion resistance and buoyancy. All these characteristic can be found in neoprene foam. Therefore, wetsuits are nowadays made by laminating of foam neoprene and elastic knitted fabric.

Neoprene is a proprietary trade name of DuPont that has become generic; it is a polychloroprene rubber (CR). It is a synthetic rubber produced by the polymerization of chloroprene with good general-purpose properties; however, its high cost limits its use to special-properties applications. It is one of the first successful synthetic elastomers, first was prepared in 1930 by Arnold Collins, a chemist in Wallace Hume Carothers's research group at du Pont. The researcher was investigating by-products of

divinylacetylene. Chloroprene (also known as 2-chlorobutadiene) is a colourless, toxic, flammable liquid with the following chemical formula (1).



Polychlorophene is obtained by the chlorination of butadiene or isoprene. In order to process chloroprene into rubber, it is emulsified in water and then polymerized through the action of free-radical initiators. Of the several structures adopted by the chloroprene repeating unit, the most common is *trans*-1,4 polychloroprene, which can be represented as follows [1]:



Apart from use for wetsuits, inertness of neoprene makes it well suited for demanding applications where resistance to oil, heat, flame, and abrasion are required, such as gaskets, hoses, belts, springs, flexible mounts and corrosion-resistant coatings. Neoprene has outstanding physical toughness, a wider operating temperature range than general purpose hydrocarbon elastomers and excellent resistance to ozone, sun and general weather conditions [2]. Neoprene's burn point is around 260°C [3]. There is no hazard in skin contact, no toxic effects are known, it is stable under normal temperature und pressures.

It was widely used in aircraft and automobile parts, sports equipment, thermal insulation materials, biomedical materials and the insulating layer of microelectronic circuits and other areas [4]. Neoprene foam can be produced in either closed-cell or open-cell form. The closed-cell form is waterproof, less compressible and more expensive. The open-cell form can be breathable. The insulation properties depend on bubbles of nitrogen gas enclosed within the material, which reduce its ability to conduct heat (fig. 1).

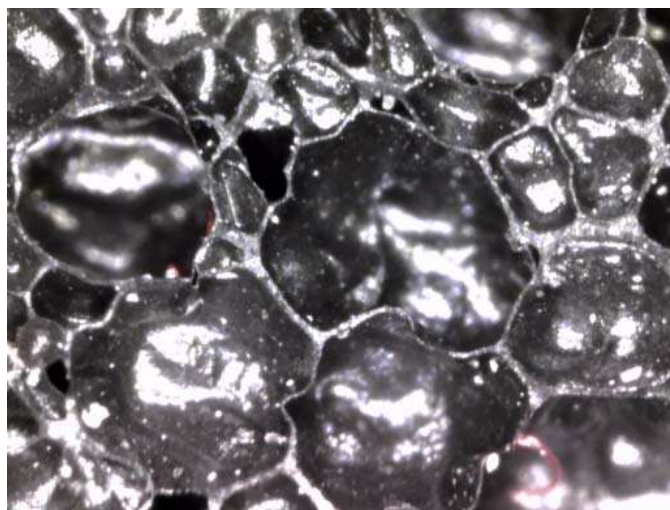

Figure 1. Bubbles enclosed within the neoprene material

The bubbles also give the wetsuit a low density, providing buoyancy in water. Regular neoprene foam is soft and stretchable, ozone resistant. Neoprene developed for deep sea diving is more compression resistant. Neoprene foam with heaviest density, hardness and higher strength is used for boots, orthopaedic and sport support products. Fire retardant neoprene is used for life jackets. Lighter and more stretchable than regular neoprene is used for surfing and triathlon suits [2]. Therefore neoprene sheet intended for wetsuit can have density of 0,15 to 0,25 g/cm<sup>3</sup>, tensile strength of 0,5 to 13,0 MPa and elongation from 100% up to 800%.

#### **DIVING SUITS AND HEAT TRANSFER**

Wetsuits are designed to protect divers from underwater environment and to reduce the thermal shock that may happen during the stay in the cold water. The clothing plays important role in the maintenance of heat balance because it modifies the heat loss from the skin surface [5]. Normally, heat transfer between the human body and environment is regulated by the following mechanisms: conduction, convection, radiation and evaporation. When the human body is in the water, two among defined mechanisms play the most important role – conduction and convection. Conduction is probably the most common mechanism of heat transfer that regularly occurs in the nature and appears between objects that are in direct contact. When the body is immersed, the heat transfer by conduction occurs between the body and surrounding water. In comparison to the air, the thermal conductivity of water is 25 times greater. Water also has ability to absorb body heat approximately 3500 times greater than air of the same volume [6]. In the water, the heat transfer through convection is caused by currents or due to movements through the water. It also needs to be pointed out that the heat transfer by convection is significantly higher in windy conditions and when waves are intensive [6].

The normal temperature of the human body, which is maintained through the mechanism of thermoregulation, is in the range 36.5 to 37.5 °C. In the cold conditions, like those that are normal for divers, the human body dissipates more heat than it absorbs. When the core temperature drops below 35.0 °C, the body is in the condition of mild hypothermia. Such condition should be treated with warm clothing, physical activity and warm drinks. The following stage of hypothermia is called moderate hypothermia and it should be treated using intravenous fluid. The most complicated type of hypothermia is called severe and it requires cardiopulmonary resuscitation, extracorporeal membrane oxygenation and even use of cardiopulmonary bypass [7].

Wetsuits are typically worn where the temperature of water is in the range 10-25°C. They provide thermal protection that depends of the level of fit, meaning that suit that is too loose on the body may not be thermally efficient. Such suits have some additional limitations among which should be pointed out the fact that water can enter the suit and increase the level of thermal discomfort. Wetsuits are made of neoprene in different thicknesses. There is a number of different wetsuits suits, but generally, suits can be divided into the following groups:

- Semi-dry suits and
- Hot water suits.

The temperature range for semi-dry suits is within 10-20°C. The advantage of such suits is the fact that suits are equipped with seals that limit the volume of water that enters into the suit and retain it for a while between the body and suit. The retained water is warmed, so diver, although in wet condition, does not suffer from cold. Semi-dry suit is produced of thick neoprene.

Hot water suits are similar to wetsuits, but they do not fit perfectly, as the wetsuits usually do. Normally, they are produced of foamed neoprene.

Additionally, during the immersion, divers may also use the dry suites and dive skins. For the most extreme conditions, dry suits are recommended. The temperature range for such suits is between -2 and + 15 °C. The construction of neoprene dry suit provides certain insulation even if the suit floods completely [8].

Dive skins are normally used where the water temperature is higher than 20.0 °C, so in comparison to other suits, they provide restricted thermal protection. For some divers, it is common to wear such suit under a wetsuit what provides additional wear comfort and maintains optimal thermal protection [9]. Dive skin suits are produced of elastane yarns.

Taking all into account, there is a significant challenge for engineers and designers to design diving suit that will be at the same time waterproof, with optimal fit and thermal comfort.

## PERFORMANCE OF DIVING SUITS: THERMAL PROTECTION MEASUREMENTS

For the last decades, different testing methods for measurement of wetsuits and their thermal characteristics have been studied by scientists. Generally, the methods can be divided into two main groups:

- a) method for measurement using thermal manikins (i.e. objective method)
- b) wear trials using human participants.

Due to the fact that the measurements of wetsuits should be performed in real-life conditions, the use of thermal manikins has certain advantage. Namely, when compared with human trials, the most important advantage is the fact that thermal manikins can be used in extreme conditions that can harm participants and are considered to be unethical to use in human trials. Among these conditions are exposure to toxic and corrosive chemical environments, flash fires, hot liquids and hot water, extremely cold water and extreme weather conditions, etc [10]. Among other advantages, it should be pointed out that thermal manikin can act as a standardized subject [10]. The table 1 gives overview of some main characteristics of two thermal manikins – submersible thermal manikin NEMO and thermal manikin TIM.

Recently, a number of investigations focused at the differences between manikin and humans have been conducted. Still, there is very limited research that will make attempt to address inter-manikin differences and manikin-human correlation in order to help to understand measurement differences and provide appropriate recommendation for the development of applicable standards for suits [11]. Among such investigations should be pointed out the pilot study that made the comparison of measurements using two manikins (NEMO and TIM) and wear trials. In the study, the heat losses (expressed as local heat transfer coefficients or local insulation values) were compared for two manikins and two human subjects wearing immersion suits with three different levels of closed cell foam insulation in two floatation positions. The results of study indicated that the variation in local heat transfer coefficients was likely due to the effects of differences in fit, folds or wrinkles in the suit materials, and was essentially random. According to the authors, these random differences then tended to average out in the calculation of the overall resistance. Finally, it is concluded that the heat loss from the manikins was a good representation of the heat loss from humans [11]. Other investigations were focused on human trials wearing wetsuits. Hall et al. compared performance and body temperature of triathletes swimming in water at 14°C with and without wetsuit. Four athletes out of ten were unable to complete swimming without wetsuit. Also, there was a significant difference in linear temperature rate change and total temperature rate change between swimming without and with wetsuit [13].



Table 1. Comparison of thermal manikins [11, 12]

	NEMO	TIM
Surface area, m <sup>2</sup>	1.86	1.80
Height, mm	1770	1778
Weight, kg	70.0	94.5
Number of zones	23	15
Shell material	Aluminium	Aluminium
Power	60Hz AC electrical power	-
Producer	Measurement Technology Northwest (USA)	CORD Group

Pavlik et al. also tested wetsuits on triathletes. They claim that wearing a wetsuits improves the swimmer performance [14]. The results of Tomakawa et al. suggest that wearing of wetsuit improve swimming performance and propulsion efficiency and, at the same time reduces energy consumption in swimming portion [15]. Prado et al. investigated the effects of wearing a wetsuit on resting cardiovascular measures. They observed that mean arterial pressure was greatest when the smallest wetsuits was worn (compared to swimming without wetsuit), [16]. Maraboti et al. also evaluated the possible cardiovascular and respiratory effect but in dry conditions. They observed a significant decrease in heart rate and cardiac output and a significant increase in total peripheral resistances [17].

Some researchers investigated wearer satisfaction when wearing diving suits. Kim et al. analyzed 15 items measuring importance of wetsuits and concluded that for female and older divers functional performance of wetsuits is more important than for male and younger divers [18].

## METHODE USED IN STUDY

Infrared thermography is gaining popularity among the researchers in various fields. In the field of textiles, the potential of thermography is used to observe the production process, material properties, clothing comfort, failure and product development [19, 20].

In this investigation, thermography is used to observe the changes in skin temperature of divers wearing neoprene diving suit immersed in sea water. For the measurement is used thermal camera FLIR E5 [21]. The specifications of used camera are given in the Table 1.

The observed body zones of divers are neck, right shoulder, right upper chest, central upper chest, left upper chest and left shoulder. The zones are defined on the basis of body mapping proposed by Smith & Havenith [22] and shown on the figure 2. The temperature of skin for each observed body zone is recorded after different intervals of immersion in water, i.e. 5, 10, 15 and 25 minutes.

Table 2. IR camera specifications [20]

Imaging and Optical Data	
IR Resolution	120 × 90
MSX Resolution	320 × 240
Thermal Sensitivity	<0.10°C
Field of View	45° × 34°
Detector	Uncooled Microbolometer
Screen	3.0 in. 320 × 240 color LCD
Frame Rate	9 Hz
Analysis	
Image Modes	IR image, visual image, MSX, thumbnail gallery
(MSX)	IR image with enhanced detail presentation
Temperature Range	0° to 150°C
(Standard Range is -20°C to +250°C (-4°F to +482°F))	



Figure 2. Observed body zones

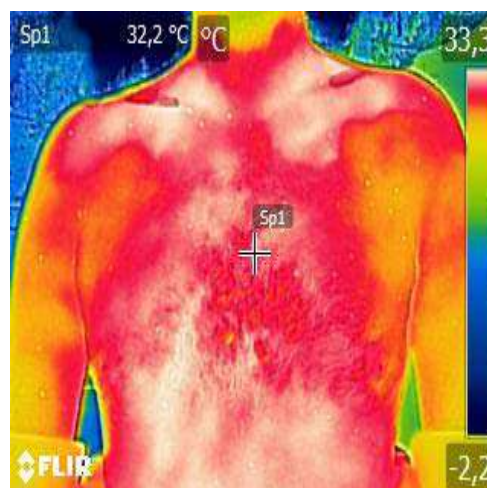

Figure 3. Thermal image of diver

## RESULTS AND DISCUSSION

In the results section are presented results of measurement on male diver who was wearing 7 mm thick neoprene diving suit. Temperature of water during all cycles of immersion was 18,4 °C. The thermogram of diver's upper body taken before the before immersion is given in fig. 3.

The figure 4 gives the overview of temperatures recorded after 5, 10, 15 and 25 min of immersion in the water, for each observed body zone. The figure 5 gives comparison between skin temperature of central upper chest of observed diver with skin temperature of central upper chest of divers in neoprene suit of 5 mm, 3 mm and no neoprene suit.

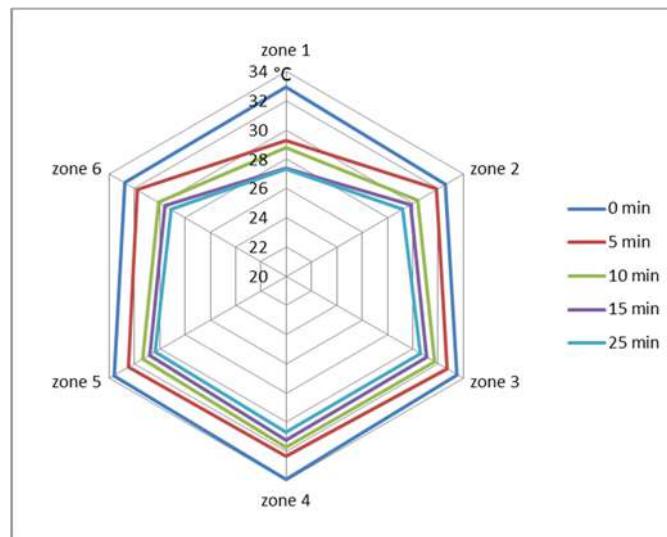

Figure 4. Distribution of temperatures

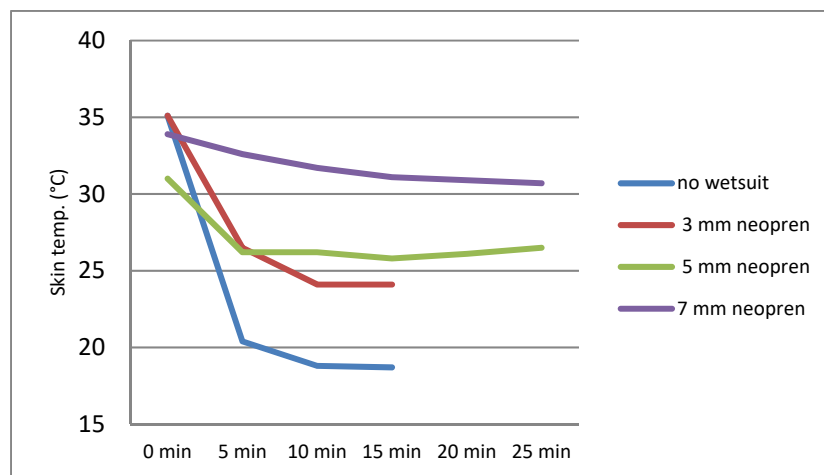

Figure 5. Comparison between skin temperature of chest of divers with 3, 5, 7 mm neoprene suit and no wetsuit

## CONCLUSIONS

Before immersion, highest body skin temperature was recorded in a central upper chest body zone, then in left and right upper chest, neck, while lower temperatures were recorded in left and right shoulders (fig.4). Highest temperature drop was recorded in a first 5 minutes of immersion in water, especially in a zone of neck. It has to be noted that neck was the only zone uncovered by diving suit. After 25 minutes of immersion, the lowest skin temperature was recorded in the zone of neck - 27,3 °C, which is 17% lower than before immersion (fig. 4, zone 1). Highest skin temperature, after 25 min of immersion in the water, was recorded in a central upper chest body zone - 30,7°C, that is 9,4 % lower than before immersion (fig. 4, zone 4). Skin temperature of central upper chest depended strongly on the type of neoprene suit. Persons without wetsuits and with thin 3 mm suit had to quit

after 15 min of experiment. The difference in skin temperature is clearly visible between persons in neoprene suits of 5 and 7 mm (fig. 5).

The outcomes of research will facilitate the process of designing wetsuits in order to increase/decrease thermal insulation in the zones that are identified and finally to maintain optimal thermal comfort. Future investigations will include measurement of temperature drop in observed body zones caused by immersions in different water temperatures and by wearing neoprene wetsuits of different thicknesses.

### **Acknowledgements**

Much obliged to the divers in family for using them as experimental subjects.

### **REFERENCES**

- [1] Neoprene (CR) chemical compound. <https://www.britannica.com/science/neoprene> (accessed July 6, 2018).
- [2] Yeh M H, Hwang W S , Cheng L R. Microstructure and mechanical properties of neoprene–montmorillonite nanocomposites. *Applied Surface Science*. 2007; 253: 4777–4781.
- [3] Neoprene. <https://en.wikipedia.org/wiki/Neoprene> (accessed July 6, 2018).
- [4] Yiming W et al. Study of High-Performance Chloroprene Sponge in Diving Suit Application, In: Proceedings of a meeting 2011 International Conference on Future Computer Science and Education, Xi'an, China. 2011.126-130
- [5] Mijović B, Skenderi Z, Salopek I. Comparison of Subjective and Objective Measurement of Sweat Transfer Rate. *Collegium antropologicum*. 2009; 33 (2): 315-320.
- [6] Lang MA, Robbins R. *Smithsonian at the Poles: Contributions to International Polar Year Science*, edited by Krupnik I, Lang A., Miller SE. Washington DC: Smithsonian Institution Scholarly Press; 2009. Scientific diving under ice: a 40-year bipolar research tool. 241–252
- [7] Brown DJ et al. Accidental hypothermia. *The New England Journal of Medicine*. 2012; 367 (20) 1930–1938.
- [8] Brewster DF, Sterba JA. Market Survey of Commercially Available Dry Suits. US Naval Experimental Diving Unit Technical Report, NEDU-3-881988. [http://archive.rubicon-foundation.org/xmlui/bitstream/handle/123456789/4868/NEDU\\_1988\\_03.pdf?sequence=1](http://archive.rubicon-foundation.org/xmlui/bitstream/handle/123456789/4868/NEDU_1988_03.pdf?sequence=1) (accessed 2.12.2018)
- [9] Ecostinger. What is the difference between stinger suit, dive skin, wetsuit, drysuit and dive suit. <http://www.ecostinger.com/blog/what-is-the-difference-between-stinger-suit-dive-skin-wetsuit-drysuit-and-dive-suit-/> (accessed July 5, 2018).

- [10] Zang H, Song G. Performance of immersion suits: A literature review. *Journal of Industrial Textile*. 2014; 44 (2): 288-306.
- [11] Mak L, et al. Thermal protection measurement of immersion suit comparison of two manikins with humans pilot, Technical Report, no. TR-2010-06 , 2010. National Research Council, Canada
- [12] Measurement Technology Northwest. Submersible thermal Manikin, MTNW, Seattle, 2016.
- [13] Hall J, Lomax M, Massey HC, Tipton MJ. Thermal response of triathletes to 14°C swim with and without wetsuits. *Extreme Physiology & Medicine*. 2015 Sep 14;4(Suppl 1):A49. A49. <https://doi.org/10.1186/2046-7648-4-S1-A49>
- [14] Pavlik J, Pupiš M, Pavlović R. Variability of swimming performance depending on the use of wetsuits. *Research in Physical Education, Sport & Health*. 2015; 4 (2): 51-55.
- [15] Tomikawa M, Shimoyama Y, Nomura T. Factors related to the advantageous effects of wearing a wetsuit during swimming at different submaximal velocity in triathletes, *Journal of Science and Medicine in Sport*. 2008; 11 (4): 417-423.
- [16] Prado A, et al. A first look into the influence of triathlon wetsuit on resting blood pressure and heart rate variability, *Biology of Sport*. 2017; 34 (1): 77-82.
- [17] Marabotti C. et al. Cardiovascular and respiratory effects of the neoprene wetsuti in non-immersed divers, *Undersea and Hyperbaric Medicine*. 2017; 44 (2): 141-147.
- [18] Kim DE, Michaelson D, Ha Y. Selection Criteria for Scuba Driver's Wetsuits. In: *International Textile and Apparel Association Annual Conference Proceedings*; 2015; Santa Fe, New Mexico. Iowa StateUniversity; 2015; p. 1-2
- [19] Salopek Čubrić I, Čubrić G, Potočić Matković VM. Thermography Assisted Analysis of Textile Materials as a Predictor of Human Comfort, In: *Book of Proceedings of the 6th International Ergonomics Conference ERGONOMICS 2016 - Focus on synergy*; 15-18 June 2016 ; Zadar, Croatia. Zagreb: Croatian Ergonomics Society. 2016.p. 295-300.
- [20] Salopek Čubrić I, Čubrić G, Potočić Matković VM. Use of Thermography to Analyse the Influence of Yarn Properties on Fabric Drying, In: Guxho G editor. *Book of Proceedings of the 7th International Textile Conference*; 2016; Tirana, Albania. Tirana: Department of Textile and Fashion at Polytechnic University of Tirana; 2016. p. 367-371.
- [21] Flir, "Flir EX- Series Infrared Cameras with MSX," <http://www.flir.com/instruments/ex-series/> (accessed 2.12.2018).
- [22] Smith C J, Havenith G. Body mapping of sweating patterns in male athlets in mild exercise-induced hyperthermia. *European Journal of Applied Physiology*. 2011; 111 (7): 1391-1404.

# POSSIBLE ROBOT APPLICATION IN GRASPING THE TEXTILE MATERIAL WITH A VACUUM GRIPER

**Goran ČUBRIĆ<sup>1\*</sup>, Marina ČUPIĆ<sup>1</sup>**

<sup>1</sup>University of Zagreb Faculty of Textile Technology, Prilaz baruna Filipovića 28a, 10000 Zagreb, Croatia, \*email: goran.cubric@ttf.hr

---

## ABSTRACT

*The use of robots in the textile and garment industry is symbolic. The main reason is the technical inability of robots to handle and transfer high deformable textile materials. The ability to manipulate cloth can be divided into three major phases of manipulation, i.e. grasping, moving and releasing, and are associated with uncontrolled deformations, insecurity on the number of grasped objects, or unexpected discharge. The aim of this paper is to investigate the possibility of grasping the textile material with the vacuum gripper mounted on the robot's hand.*

## KEYWORDS

*Grasping, robots, textile, vacuum, gripper*

---

## INTRODUCTION

Compared to humans, robots are more reliable, more precise, work with minor mistakes, do not need rest, and can work in dangerous or difficult environments. Despite success in other industrial sectors, the use of robots in the textile and fashion industry is quite limited. Due to the problem of manipulation with textile materials, we cannot speak of their wider use in textile and clothing manufacturing processes. Robotic manipulation of textile materials is problematic, which is the reason robots are not widely present in textile and clothing manufacturing processes. Besides handling materials, robots can perform other tasks if equipped with appropriate tools [1]. Cutting is one of those tasks. Advanced cutting involves laser cutting, water jet cutting, ultrasonic and high frequency cutting. Deciding which types of cutting are most suited depends on the type of material being trimmed or cut, the design of the part and other factors [2].

The second main task is to connect tailored parts to provide clothes. Robots are involved in the process of holding and orienting sewing pieces with maintaining material tension, and in that way help sewing machine. Besides traditional sewing with threads, new joining techniques can be used in the clothing industry, such as ultrasound and laser [3]. Their application is even greater in the manufacture of technical textiles due to the need for 3D joining.

Among the tasks where robots may appear are picking up, laying/positioning and immobilizing, sewing, ironing/pressing, inspecting, folding and packaging. Along the years different types of devices

(grippers) for those purposes are developed. Such grippers could be mounted on a robot. In this sense, we can distinguish mechanical impactive (pinch and/or clamp grippers) and ingressive (intrusive, i.e., needles, and nonintrusive like velcro and carden or brush), surface attraction which in turn can be based on suction (vacuum, Bernouilli, etc.) or electrostatic, and finally of the contigutive type, with the variants of chemical (washable) adhesion, thermal cryogenic (freezing water), or thermal melting resin [4].

Mechanical grippers are the most popular in the textile industry due to their simple construction and reliability [5-8]. Beside mechanical grippers, vacuum grippers can be also used in textile and clothing industry. Some authors examined the possibility of catching the textile material with vacuum. Other authors investigate grasping the textile materials with grippers that consist of two or more identical or different principles of material grasping [9-14].

Ironing is another task that can be done with a robot. The robot, just like the human, takes the iron and iron your garment and performs 4 tasks: handling textile materials, positioning, smoothing textiles and ironing. During ironing, the robot mimics human movements, regulates the ironing temperature, and releases the required amount of steam [15, 16].

Assistive robots, on the other hand, have great potential to address people aging-related issues and increased custody requirements. One of the basic activities of everyday life where robots could play auxiliary roles is dressing [17, 18].

The aim of this paper is to preliminary investigate the grasping of woven fabric by a vacuum gripper in the textile and clothing industry. The vacuum gripper is mounted on Mitsubishi robot that is located in Laboratory for Mechanics and Automation in Clothing industry at the Faculty of Textile Technology.

## **EXPERIMENTAL**

For this experiment, a flat vacuum suction cap is chosen. The image of vacuum suction caps is shown in the Fig. 1a. The vacuum gripper is mounted on a Mitsubishi RV-2AJ robot. Vacuum is obtained by an ejector that has a maximum vacuum of 0,48 bar. The ejector is shown in the Figure 1b.

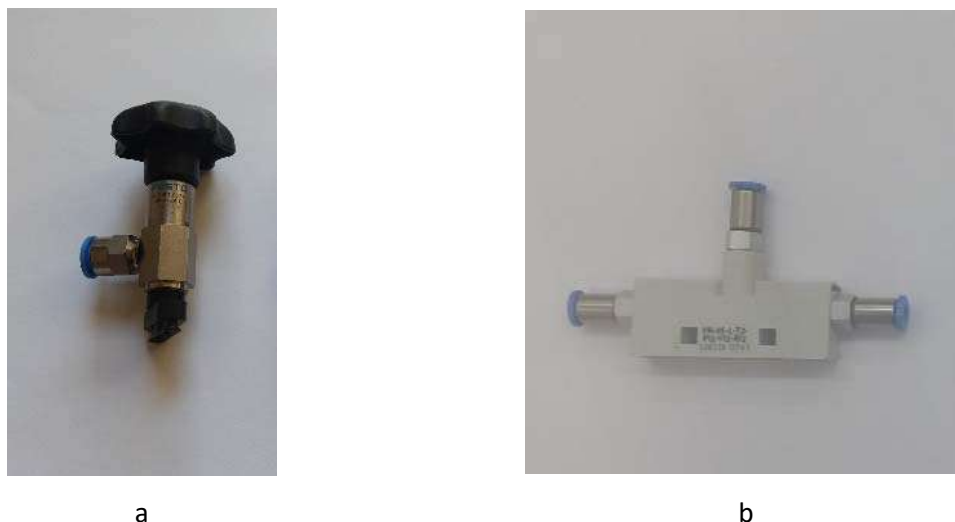

Figure 1. Experimental equipment a. Flat vacuum suction cap, b Ejector

For the experiment seven woven materials are prepared. Materials are chosen to differ according to the thickness and surface mass. The fabric thickness is determined by using the thickness meter with precision 0.01 mm. The fabric surface mass is determined on an analytical scale with precision 0.0001 g. The total selection of 7 samples with determined characteristics is described in the Table 1.

Table 1: Characteristics of selected woven materials

Nr.	Sample ID	Measured properties	
		Surface mass, g/m <sup>2</sup>	Thickness, mm
1	S1	1,1224	0,28
2	S2	1,4590	0,29
3	S3	2,0680	0,34
4	S4	1,1678	0,29
5	S5	2,7725	0,58
6	S6	1,2695	0,35
7	S7	1,5544	0,33

For the purposes of this study, programs to transfer the woven material with two different lifting height (5 cm and 10 cm) from flat surface were used. Woven materials are cut into samples with dimensions 100 x 100 mm.



## RESULTS AND DISCUSSIONS

The results of grasping with a flat vacuum suction cap with two lifting heights are presented in Table 2. Mark Y means that the material is successfully lifted and mark N that material is dropped from the gripper. Figure 2 shows the grasping of sample S1 using the RV-2AJ robot when the sample is raised 50 mm or 100 mm over the working desk.

Table 2: Results of investigation

Sample ID	Lifting	
	50 mm	100 mm
S1	Y	Y
S2	Y	Y
S3	Y	N
S4	Y	Y
S5	Y	Y
S6	Y	Y
S7	Y	N



50 mm

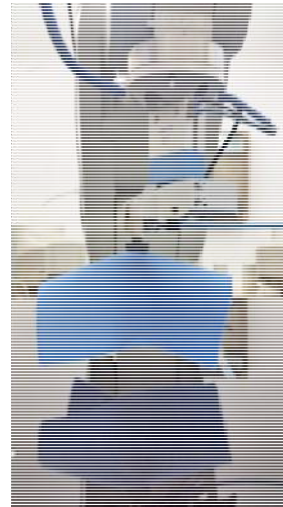

100 mm

Figure 2 Grasping and lifting sample S1 using the RV-2AJ robot on height of 50 mm and 100 mm from the working desk.

As stated in the introduction, the focus of this research is to preliminary investigate the grasping of woven fabric by vacuum gripper that is mounted on a Mitsubishi RV-2AJ robot. Firstly, the possibility of grasping woven material on height of 50 mm from the working desk is examined. From the results presented in the Table 2, it can be seen that all samples of woven material are grasped and lifted. Moving the robot from left to right, the material remained grasped. When grasping was resumed and the material lifted to 100 mm height, different results were obtained. Two samples fell off from

the gripper (Sample S3 and S7). Sample S3 has a surface mass greater than 2,0 g/m<sup>2</sup> and this could be the cause of unsuccessful lifting. However, the S5 sample has a surface mass greater than 2.7 g/m<sup>2</sup> and has been successfully lifted to the given height. If we observe only the thickness of the material, it could be noted that S5, having the largest thickness of 0.58 mm, has been successfully raised to a height of 100 mm. Samples S3 and S7 have a similar thickness (0.34 and 0.33 mm) and fell off from the gripper when raised to 100 mm height, while example S6 (thickness 0.35 mm) was successfully held by a vacuum gripper.

This would mean that surface mass and thickness are not the only parameters that affects the grasping and lifting of the woven fabric. Probably the material draping properties are quite relevant in this sense. More than a proof, it is that the experiment with sample S7 reinforces this impression. A real proof would require to taking the draping properties into account. It has a surface mass of 1.55 g/m<sup>2</sup> and the gripper has not been able to lift it at 100 mm height. Also sample S2 has very similar surface mass and thickness (1,459 g/m<sup>2</sup>; 0,29 mm) as sample S7 (1,5544 g/m<sup>2</sup>; 0,33 mm) but it did not fall from gripper at 100 mm height. All this leads to the conclusion that in future studies have to be taken into account, beside surface mass and thickness, another characteristic of the material – material draping.

## CONCLUSIONS

The purpose of this research was to preliminary investigate the possibility of grasping and lifting woven materials with a robot on which a vacuum gripper is mounted. The obtained results indicate that the two observed parameters of the materials (surface mass and thickness) are not enough to evaluate their graspability with a vacuum gripper, but other characteristics of the material have to be taken into account as well. One of these characteristics will certainly be the drape of the material.

## REFERENCES

- [1] G. Nikolić, B. Katalinić, D. Rogale, B. Jerbić, G. Čubrić: Robots and use in textile and clothing industry (in Croatian), University book, Zagreb, ISBN 978-953-7105-22-8, Zrinski d.d. Čakovec, 2008.
- [2] B. Brumson: What material Removal process is right for you?, [https://www.robotics.org/content-detail.cfm/Industrial-Robotics-Industry-Insights/What-Material-Removal-Process-is-Right-for-You/content\\_id/1081](https://www.robotics.org/content-detail.cfm/Industrial-Robotics-Industry-Insights/What-Material-Removal-Process-is-Right-for-You/content_id/1081)
- [3] M. Čupić: Application of robots in the textile and clothing industry, graduate thesis, Zagreb, 2018.

- [4] P. Jimenez, G. Čubrić: Robots in the textile and fashion industries: facts and perspectives, 11th Scientific-Professional Symposium Textile Science and Economy, Zagreb, 2018.
- [5] K. Salleh, H. Seki, Y. Kamiya, M. Hikizu: Inchworm robot grippers for clothes manipulation, *Artificial Life and Robotics*, vol. 12, pp. 142–147, march 2008.
- [6] G. Alenya, A. Ramisa, F. Moreno-Noguer, and C. Torras: Characterization of textile grasping experiments, in *Proceedings of the 2012 ICRA Workshop on Conditions for Replicable Experiments and Performance Comparison in Robotics Research*, (St Paul (MN)), pp. 1–6, 2012.
- [7] S. Miller, J. van den Berg, M. Fritz, T. Darrell, K. Y. Goldberg, and P. Abbeel: A geometric approach to robotic laundry folding, *International Journal of Robotic Research*, vol. 31, no. 2, pp. 249–267, 2012.
- [8] M. Shibata, S. Hirai: Fabric manipulation utilizing contacts with the environment, in *2012 IEEE International Conference on Automation Science and Engineering, CASE 2012*, Seoul, Korea (South), August 20-24, 2012, pp. 442–447, 2012.
- [9] G. Cubric, G. Nikolic: Applying the vacuum gripper for knitted fabric transfer. *Melliand International*, 19(3), 167-168, 2013.
- [10] M.A. Ayub, M.R. Jackson: Intelligent handling system for deformable web materials. *Proceedings of the International Conference on Mechatronics and Technology ICMT 05*, UTM, Kuala Lumpur, 2005.
- [11] M. T. Kordi, M. Hüsing, B. Corves: Development of a Multifunctional Robot EndEffector System for Automated Manufacture of Textile Preforms. *IEEE/ASME International Conference on Advanced Intelligent Mechatronics*, ETH Zürich, Switzerland, 2007.
- [12] Reinhart G., Straßer G.: Flexible gripping technology for the automated handling of limp technical textiles in composites industry, *Production Engineering - Research and Development* . 5(3), 301-306, 2011.
- [13] Löchtea C., Kunzb H., Schnurra R., Langhorsta S., Dietricha F., Raatzc A., Dilgerb K., Dröder K.: Form-Flexible Handling and Joining Technology (FormHand) for the Forming and Assembly of Limp Materials, *CIRP Conference on Assembly Technology and Systems*, 2014.
- [14] Bruns C., Micke-Camuz M., Bohne F., Raatz A.: Process design and modelling methods for automated handling and draping strategies for composite components, *CIRP Annals - Manufacturing Technology*, 67 (1–4), 2018.
- [15] J.S. Dai: Task analysis and motion generation for service robots: With reference to region segregation and path generation for robotic ironing, In *Service Robots and Robotics: Design and Application*, chapter 3, (2012), ISBN 978-1-466-0291-5, pp. 30–50

- [16]D. Uria: Spanish university develops humanoid ironing robot, June 23, 2017.  
[https://www.upi.com/Odd\\_News/2017/06/23/Spanish-university-develops-humanoid-ironing-robot/8951498242806/?utm\\_source=sec&utm\\_campaign=sl&utm\\_medium=6](https://www.upi.com/Odd_News/2017/06/23/Spanish-university-develops-humanoid-ironing-robot/8951498242806/?utm_source=sec&utm_campaign=sl&utm_medium=6)
- [17]A. Jevtic, A. Flores Valle, G. Alenya, G. Chance, P. Caleb-Solly, S. Dogramadzi,, C. Torras,,:  
Personalized Robot Assistant for Support in Dressing, IEEE TRANSACTIONS ON COGNITIVE AND  
DEVELOPMENTAL SYSTEMS, 2017.
- [18]G. Chance, A. Jevtic, P. Caleb-Solly, S. Dogramadzi: A Quantitative Analysis of Dressing Dynamics  
for Robotic Dressing Assistance, Bristol Robotics Laboratory, University of the West of England,  
Bristol, UK, 2 Institut de Robòtica i Informàtica Industrial, CSIC-UPC, Parc Tecnològic de Barcelona,  
Barcelona, Spain, 2017., Volume 4, Article 13.

# CONSTRUCTION OF A DRESS FOR SCHOOL AGED GIRLS

Zola RADIĆ<sup>1</sup>, Renata HRŽENJAK<sup>1\*</sup>

<sup>1</sup>University of Zagreb Faculty of Textile Technology, Prilaz baruna Filipovića 28a, 10000 Zagreb, Croatia, \*email: renata.hrzenjak@ttf.hr

---

## ABSTRACT

*A child is like an adult an individual for himself and his growth and development do not necessarily have to accompany his age group. This should be a guide for designing suitable clothing for children. The paper describes the history of clothing for children, their growth and development. Accordingly, anthropometric measurements and clothing sizes are shown. The basic design of the dresses „School girl“ and „Vala“ for school aged girls and the modelling procedure were also described. As a result pattern construction and prototype model are presented.*

## KEYWORDS

*clothing construction, children's clothes, dress*

---

## INTRODUCTION

The research in this paper was inspired by the idea of making a dress for girls on the occasion of the first day of elementary school. Clothing production is a long-lasting process and first and foremost it is necessary to know and study the proportions of the child's body.

Based on the observed proportions, deviations from normal body can be observed, as opposed to measurements in adults where, for example, the length of the bust girth or hip, as the starting point, for children is a starting measurement for the further construction of the clothing item itself, the body height of the child [1,2].

This paper presents a history of clothing for children, from which it can be concluded that children's fashion has emerged from the principle of copying adult clothing since the 18<sup>th</sup> century, and today results in mass production of children's clothing and fashion as a separate branch in fashion design.

In addition to the studied theoretical part related to growth, development, proportions, anthropometric measurements and clothing sizes of children, an experimental part was explained and conducted. The experimental part contains a description of the design and modelling of the dress pattern for school aged girls. As a result, the prototype of the dress model for girls called "Vala" is shown.

## Children's clothing through history

Since ancient civilizations of Egypt, Greece, Rome and Byzantium, the children dressed in the same way as their parents. By the end of the 18<sup>th</sup> century, children's clothing began to be made in their own style and the children did not look like a miniature adults. At the beginning of the 19<sup>th</sup> century, the new styles featured a very formal look, and the real revolution in children's clothing took place after the Second World War when children began to dress informally and sportily as the style is nourished today [3].

More specifically, in the old age at the time of Greeks and Romans, the children wore large, adult clothes, Greeks wore chiton and Roman tunic. Newborns were wrapped in swaddling bands or they were undressed. The transition of traditional Roman, classical clothes took place gradually. During the period of the Byzantine empire, the basic clothing item remained tunic, while in the west Europe, the northern tribes inform Europeans with the trousers, later this style with the classic European clothing of that period was mixed [4].

The first big changes in clothes occur in the second half of the 15<sup>th</sup> century, the clothes become cropped and two-piece, respectively, cut into the upper and lower part. By 1760 the already well-established fashion was for little boys and girls to wear white dresses called frocks (Figure 1.) [5, 6].

Frocks wear the boys up to 3 years of age after which they wear the skeleton suit. It consisted of trousers with narrow legs but a loose fit over the hips and buttocks, buttoned to a short jacket; a shirt with a wide neck opening; and a big collar edged with frills. Until then, trousers had been worn only by particular occupational groups, like sailors and workmen [7].



Figure 1. Frocks [6]

Since the 1880s, the trend has become the famous sailor suits for boys and girls. After the First World War, the trousers became clothes for both boys and girls of all ages because it is functional for playing, climbing, jumping, running and other activities in the daily life of a child [4].

Today, children's clothing is produced in a variety of styles, ranging from the choice of clothing such as those for adults to pieces of clothing associated with the popular culture for children. The wide range of clothing accessories for children is accompanied by equally large sales prices of the products themselves, so today's production of children's clothing and its design has come to the forefront with adults [2].

### **Growth and development of children**

Further research of the child's body and its proportions is conditioned by knowing some of the most important facts related to its growth and development.

The term growth in the narrower sense includes quantitative changes - increase in mass and size resulting in the multiplication of cells and intercellular substance. These changes can be measured. The development applies to qualitative changes and an increase in the complexity of structure and function of organs and tissue. These two terms cannot be separated from each other because they depend on each other. They supplement each other and have the unique meaning, including both qualitative and quantitative changes. Growth intensity is not the same during the development period. The rate of body growth reduces continuously. It is the greatest in the intrauterine period. A child develops that is approximately 50 cm long and about 3,400 g heavy at birth. Although male infants are on average somewhat longer and heavier than female infants, the growth of boys and girls occurs with the same intensity until about the age of 10 years. After that the girls develop faster, and their growth ceases earlier. In the first year after birth the increase in body length ranges from 26 to 28 cm, and the increase in weight is about 7 kg. Afterwards the growth decelerates even more. At the age of 4 to 5 years of life the children grow at a fairly stable rate with a slow reduction of annual height increase. The growth accelerates again in the period, which complies with sexual maturity. This height and weight increase, called "adolescent growth spurt", lasts mostly for a year and a half to two years. It is the most intensive in the period of about 12 months, when reaches the growth rate of the second year of life. The fastest height gain precedes the fastest weight gain [2, 8].

Growth acceleration in children does not occur at the same time, but:

- in girls it occurs between 10 and 13 years of age, while in boys it occurs two years later
- after this rapid acceleration the growth decelerates even for a few years; in girls it fully stops between 16 to 17 years of age, and in boys it stops between 18 to 19 years of age.

The development and growth of a child is influenced by various genetic and environmental factors such as genetic structure or genotype, hormonal influences, nutrition, diseases, psychological

stress and socioeconomic factors. The developmental period of man covers almost a quarter of his entire life in the course of this development, the child is constantly changing. In different phases of the same child completely different features develop. Some features are characteristic of all children. To facilitate the understanding of biological, health and educational problems of children and youth of different ages, the whole growth and development period was divided into several phases.

According to the scheme of Anglo-Saxon authors, which is often used, the following is differentiated when considering the human development:

- intrauterine period,
- infancy period - from birth to 11 months
- small children - 12 to 23 months
- preschool period - from 2 to 5 or 6 years
- early school period or middle childhood
  - from 6 to 10 years for girls
  - from 6 to 12 years for boys and
- adolescent period - from 11 to 18 years for girls and from 13 to 20 years for boys.

In Croatian pedagogical practice another division of the developmental period is used:

- intrauterine period,
- early childhood:
  - infancy period (from birth to 11 months)
  - infant nursery period (from 1 to 2 years)
  - preschool period (from 2 to 5 or 6 years)
- school period (from 6 to 18 years).

No scheme should be understood inflexibly because the periods are not strictly limited. Growth is a continuous process, and the child gradually passes from one period into another - faster or more slowly, pursuing its individual growth rate [8].

### **Proportions of the child's body**

The proportion (lat. Proportion - proportionality, harmony) is the ratio between the individual parts of the whole or the ratio of one part to the whole, hence the size ratio. Polykleitos was the first in Greece in canon art that has theoretically explained the ideal proportions of the human body. At the time of the Renaissance, a special concept of ideal proportions was formed in painting and architecture, so-called golden ratio [2]. Albrecht Dürer included in his methodological researches women who were considered to have no proper proportions and children who were previously shown as miniature adults. This has led to significant changes in the understanding of gender and age differences in the morphology of the human body (Figure 2) [9].



According to growth and development, a child of certain age has certain proportions, which were graphically presented by professors of medicine Robbins, Brody, Hogan and Roth at Yale University in the United States in 1928. Their drawings are taken as a standard in the professional literature, according to which the head is in the infant's  $\frac{1}{4}$  body, and in the adult man's head is  $\frac{1}{8}$  of the standing height [2, 10].

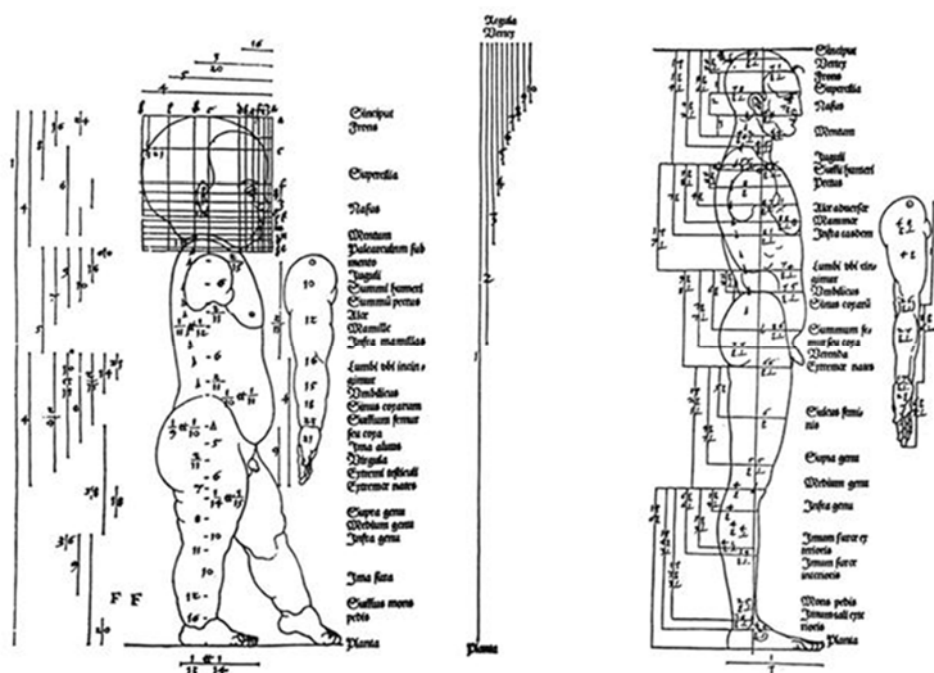

Figure 2. Proportions of the child and adult man according to Albrecht Dürer [9]

### Anthropometry of children and youth

Anthropometry can be defined as a science that deals with human body measurement. The name is derived from the Greek words "anthropos" and "metrein" meaning "man" and "measure". Pheasant further extended this definition to "applied anthropometry," which included numerical data related to the size, shape, and other physical characteristics of people and can be used in the context of fashion design [11]. The aim of this science is to determine the differences between individuals and groups of people in terms of gender, age, race, etc. With regard to the topic of this paper, anthropometry of children and youth will be investigated more in detail.

The first large anthropometric survey of children's sizes and measures was performed by the US Department of Agronomy between 1937 and 1939. The aim of this review was to obtain accurate measurements for the construction and grading of patterns for children's clothing and also to obtain unique measurements among the manufacturers of children's clothing in the United States. In total, over two and a half years, there were over 147,000 children aged between 4 and 17 years with a total of 36 measurements including body mass. After the data analysis, a sizing system based on body height

and hip girth was developed. The report of this review was first published in 1941 and it has become a guide to the development of a size designation system of children's clothing [2, 12, 13].

Since people are different in terms of body height and development, a thorough human body research is required. A large number of proportions have to be studied to produce the clothes, after which it is possible to establish the relationship between the individual parts of the body or the individual measurements. Within the scope of STRIP Project Croatian Anthropometric System, anthropometric measurement of the population was carried out with the aim of adopting the anthropometric system CAS as the underlying basis for size designation system for clothing and footwear. Systematic measurement includes 20 Croatian counties and the City of Zagreb. The measurements are divided into 55 age groups, from infants to children up to 5.4 years of age, preschool children, school children, boys and girls, and adult population ranging from 20 to 82 years of age. Determination of measurements was carried out in accordance with the International Standard ISO 8559 and ISO 3635 [14].

### Size designation system for children's clothing

The dominant primary measurement for size designation system of children's clothing, whether small children, boys, young men, young girls or girls are body height irrespective of age. This is determined because children in their development show very big differences in body height in those same years. Despite this fact, children's clothing is often labelled only through age. In this case it serves as a rough guide to the clothing size. For the purposes of clothing designation, all children are best grouped into a) infants b) boys and c) girls, where the separation boundary between infants and other children is body height of 104 cm. For the further construction of the dress for girls, a table of articles of clothing and measurements is necessary to indicate their size for young girls and girls according to HRN EN 13402-2 [2, 15].

Table 1. Types of articles of clothing and the measurements needed for size labelling of young girls and girls [14, 15]

Articles of clothing	Primary measurement	Secondary measurement
Dresses	Body height	Bust girth
Knitwear (sweatshirts, sweaters)	Body height	Bust girth
Blouses	Body height	Bust girth
	Underwear	
Undershirts, sweatshirts	Body height	Bust girth
Underpants	Body height	Waist girth
Pajamas	Body height	Bust girth
Swimwear and bathing suits	Body height	Underbust girth Bust girth

Table 2. Size designation of clothes for female infants, young girls and girls according to HRN EN 13402-3 [2, 15]

Primary and secondary measurements (cm)								Interval (cm)
Body height	44	50	56	62	68	74	80	6
Range	41-47	47-53	53-59	59-65	65-71	71-77	77-83	
Bust girth	40	42	44	46	48	50	52	2 i 1
Range	39-41	41-43	43-45	45-47	47-49	49-51	51-53	
Waist girth	40	42	44	46	47	48	49	2 i 1
Range	39-41	41-43	43-45	45-46,5	46,5-47,5	47,5-48,5	48,5-49,5	

Table 2. Size designation of clothes for female infants, young girls and girls according to HRN EN 13402-3 (appendix) [2, 15]

Primary and secondary measurements (cm)								Interval (cm)
Body height	86	92	98	104	110	116		6
Range	83-89	89-95	95-101	101-107	107-113	113-119		
Bust girth	53	54	55	56	57	58		2 i 1
Range	53-53,5	53,5-54,5	54,5-55,5	55,5-56,5	56,5-57,5	57,5-59,5		
Waist girth	50	51	52	53	54	55		2 i 1
Range	49,5-50,5	50,5-51,5	51,5-52,5	52,5-53,5	53,5-54,5	54,5-55,8		
Primary and secondary measurements (cm)								Interval (cm)
Body height	122	128	134	140	146	152		6
Range	119-125	125-131	131-137	137-143	143-149	149-155		
Bust girth	61	64	67	70	73	76		3
Range	59,5-62,5	62,5-65,5	65,5-68,5	68,5-71,5	71,5-74,5	74,5-77,5		
Waist girth	56,5	58	59,5	61	62,5	64		1,5
Range	55,8-57,3	57,3-58,8	58,8-60,3	60,3-61,8	61,8-63,3	63,3-64,8		
Primary and secondary measurements (cm)								Interval (cm)
Body height	158	164	170	176	182	188		6
Range	155-161	161-167	167-173	173-179	179-185	185-191		
Bust girth	79	82	85	88	91	94		3
Range	77,5-80,5	80,5-83,5	83,5-86,5	86,5-89,5	89,5-92,5	92,5-95,5		
Waist girth	65,5	67	68,5	70	71,5	73		1,5
Range	64,8-66,3	66,3-67,8	67,8-69,3	69,3-70,8	70,8-72,3	72,3-73,8		

Size designation systems are of general interest to producers and consumers, or to the entire population. They prescribe clothing sizes and determine how they are labelled. There are no unified world size designation systems, but as a rule each country prescribes for itself, based on anthropometric measurements. Measurements are usually carried out every ten years, and standards are improved on the basis of these. This is necessary because of the conditions and lifestyles that directly reflect the human body measurements [14].

## EXPERIMENTAL

### Materials and Methods

In the experimental part two constructed models of the dress for girls called "School Girl" and "Vala" were presented.

The model of dress called "School Girl" has single breasted with 8 buttons (Figure 3.). The back of the dress is in one part. Sleeves are also consist of one part and they are shortened to 10 cm. The collar consists of two parts. At the waist line there is a belt that make a ribbon. The length of the dress compared to the construction pattern is shortened by 7 cm and slightly rounded. The model has a 8 cm wide pocket on the bust area [1].



Figure 3. a. Sketch of model "School Girl", b. Pattern parts of model "School Girl" [1]

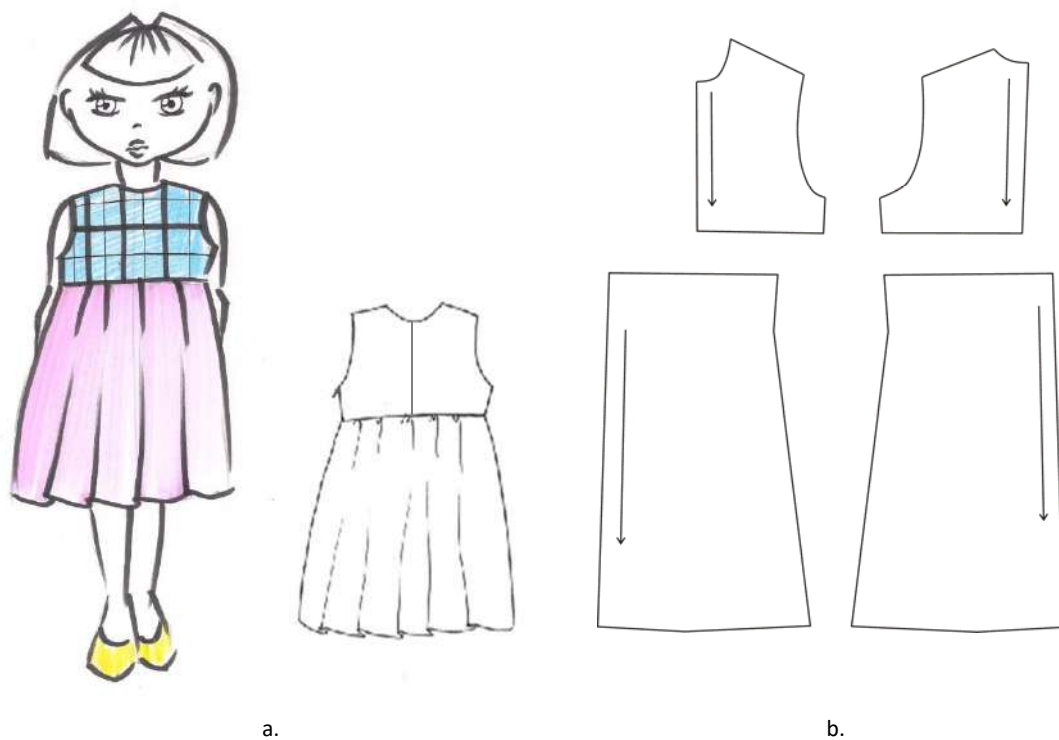

Figure 4. a. Sketch of model "Vala", b. Pattern parts of model "Vala" [1]

The dress model "Vala" consists of two parts (Figure 4.). The upper part is cut to the body and reaches the height between the line of the bust and the waist. The lower part is much wider and reaches the length up to below the knees and the length is slightly rounded. This model has no sleeves. The modelled pattern is split into two parts. The lower part was then further dissolved and expanded. The scye depth is deepened by 2 cm and the shoulder seam is shortened by 2 cm. The length of the dress is slightly rounded [1].

## RESULTS AND DISCUSSIONS

The dress model "Vala" was selected for production and representation of the model prototype. The model consists of two types of fabric. For the upper part, a cotton-painted star-coloured linen was used (Figure 5. a.), and for the lower part, a crep print 100% polyester (Figure 5. b.). Inside the dress is cotton fabric lining.



Figure 5. Fabric used for dress model "Vala": a. upper part, b. lower part

Figure 6. presents the prototype of the dress model for school aged girls called "Vala". The model is presented in front (Figure 6. a.), in sideways (Figure 6. b.) and at the back (Figure 6. c.).

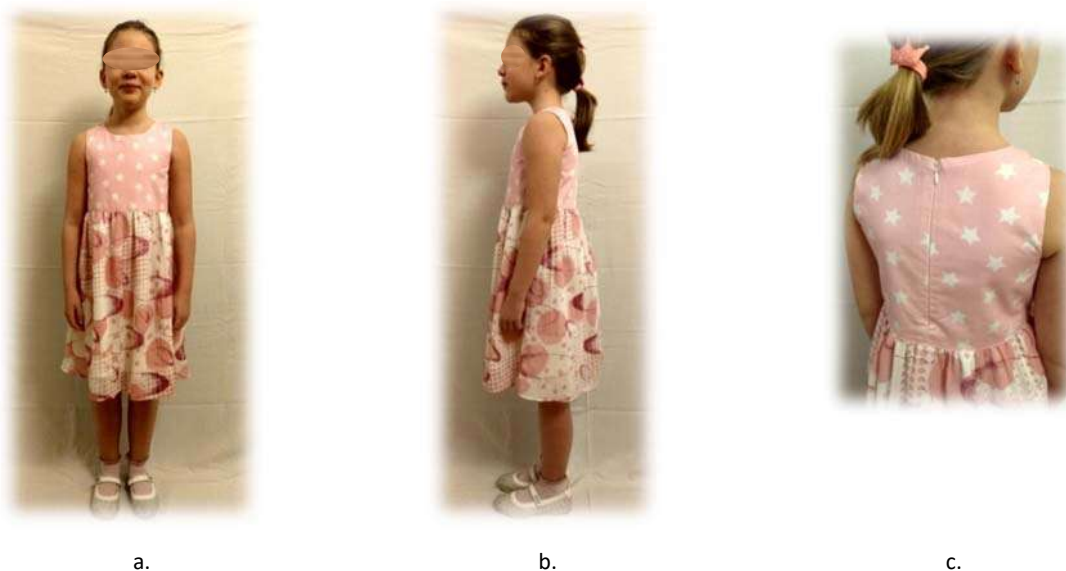

Figure 6. Dress model "Vala" for school aged girl: a. front, b. sideways, c. back

The buttoning is made at the back with a concealed zipper as shown in Figure 6. c. The model is widened in the lower part, and because of the cotton fabric in the upper part and in the lining is comfortable to wear. This is very important because the child can move freely and perform his school activities.

## CONCLUSIONS

By researching the topic of this paper, the importance of the proportions of the child's body and their role in the clothing production is perceived. Children's fashion as a late fashion branch in the fashion industry required their own research and measurements, after which it was established that

height, as the main body measurement for clothing production, creates clothing designation systems for children. By creating such systems, the quality of the children's clothes and their comfort and acceptance have contributed to it. Despite the established standards, it should be kept in mind that a child as an adult is an individual for himself, and his growth and development do not necessarily have to accompany his age group [1].

## REFERENCES

- [1] Radić, Z. Konstrukcija haljine za djevojčice školske dobi. [Bachelor thesis]. Zagreb: Sveučilište u Zagrebu Tekstilno-tehnološki fakultet; 2018.
- [2] Hrženjak, R. Utjecaj tjelesnih proporcija djece i mladeži kao osnove za konstrukciju odjeće. [dissertation]. Zagreb: Sveučilište u Zagrebu Tekstilno-tehnološki fakultet; 2012. 231 p.
- [3] Davenport, V. Kids clothes. England: A Dorling Kindersley Book; 2005.
- [4] Grau, F. Povijest odijevanja. Zagreb: Naklada Jesenjski i Turk; 2008.
- [5] Baumgarten, L. Children's clothing [Internet]. [cited 2018 Nov 28] Available from: <http://www.history.org/history/clothing/children/child01.cfm>
- [6] 18th c. baby dresses, Sturbridge [Internet]. [cited 2018 Aug 23] Available from: <https://janeaustrworld.wordpress.com/tag/18th-century-children/>
- [7] Berggren Torell, V. Children's clothes [Internet]. Berg Encyclopedia of World Dress and Fashion: Volume 8 – West Europe, Part 9: Peoples and Dress. Berg Publishers; 2010 [cited 2018 Jul 20] Available from: DOI: 10.2752/BEWDF/EDch8076
- [8] Prebeg, Ž. Growth and development of children and youth. Theoretical aspects and application of Croatian Anthropometric System. Zagreb: University of Zagreb, Faculty of Textile Technology; 2010. p. 61-72
- [9] Zenić, P. Proporcije ljudskog lika kroz povijest umjetnosti [Internet]. [cited 2018 Jul 20]. Available from: <http://likovna-kultura.ufzg.unizg.hr/Ucimo-gledati-zine/Broj%201/proporcije%20ljudskog%20lika.htm>
- [10] Behrman, R. E., Vaughan, V. C., Nelson, W. E. Nelsons textbook of pediatrics. Philadelphia, London, Toronto, Montreal, Sydney, Tokyo: Saunders (14<sup>th</sup>); 1992.
- [11] Ujević, D. et al. Anthropometry of human body. Theoretical aspects and application of Croatian Anthropometric System. Zagreb: Tekstilno-tehnološki fakultet Sveučilišta u Zagrebu; 2010. p. 73-81
- [12] Cooklin, G. Pattern grading for children's clothes, The technology of sizing. Oxford: BSP Professional Books, Alden Press; 1991.

- [13] O'Brien, R. Body measurements of American boys and girls for garment and pattern construction, Comprehensive report of measuring procedures and statistical analysis. United States Department of Agriculture: Textiles and clothing division, Bureau of home economics, Miscellaneous Publication No. 366; 1941
- [14] Ujević, D. et al. Hrvatski antropometrijski sustav: Podloga za nove hrvatske norme za veličinu odjeće i obuće. Zagreb: Tekstilno-tehnološki fakultet Sveučilišta u Zagrebu; 2006.
- [15] HRN EN 13402 (1.-3. dio):2008, Označivanje veličina odjeće – 1. dio: Nazivi, definicije i postupak mjerenja tijela (ISO 3635:1981, MOD; EN 13402-1:2001); 2. dio: Primarne i sekundarne dimenzije (EN 13402-2:2002) i 3. dio: Mjere i intervali (EN 13402-3:2004)



**Fibers, yarns, fabrics, technical textiles  
& nonwovens**

**TZG**

# ANALYSIS OF ADVANCED TEXTILE MATERIAL FOR AUTOMOTIVE APPLICATION

Ivana SCHWARZ<sup>1</sup>, Ružica BRUNŠEK<sup>1\*</sup>, Zorana KOVAČEVIĆ<sup>1</sup>, Stana KOVAČEVIĆ<sup>1</sup>

<sup>1</sup>University of Zagreb Faculty of Textile Technology, Prilaz baruna Filipovića 28a, 10000 Zagreb, Croatia, \*email: ruzica.brunsek@ttf.hr

## ABSTRACT

The materials that are classified in the Mobiltech area, as a field of technical textiles, are witnessing fast growth, development and its share in the world textile market. Following the global ecological strategies, there is an increasing emphasis on the production and application of advanced textile materials with an ecological component, which will concurrently meet the high demand of the market. Accordingly, this paper presents an analysis of the textile material used for automotive application.

The subject of the research is a textile material consisting of two components - woven and non-woven fabric, constructed in the way that the face and back of the fabric are made of nonwoven fabric, while the interior is made of woven fabric. The complex technological process of producing this material results in the realization of a textile material with exceptional properties, essential for the automotive application, such as softness, pliant and low mass, while retaining the properties of strength, resistance and comfort. Furthermore, this textile material satisfies a particularly important visual segment of aesthetic attractiveness as well as ecological acceptability.

## KEYWORDS

Textile material, fabric structure, woven and nonwoven fabric, automotive application, ecological aspect

## INTRODUCTION

The materials that are classified in the Mobiltech area, as a field of technical textiles, imply an industry that is one of the most important users of technical textiles. Observing the world's production of technical textiles, it can be concluded that about 24% of the share belongs to Mobiltech field, witnessing fast growth, development and share in the world textile market. Approximately 25 kg of textiles are incorporated in one average personal car (Figure 1), of which over 18% comprise car seat upholstery [1, 2].

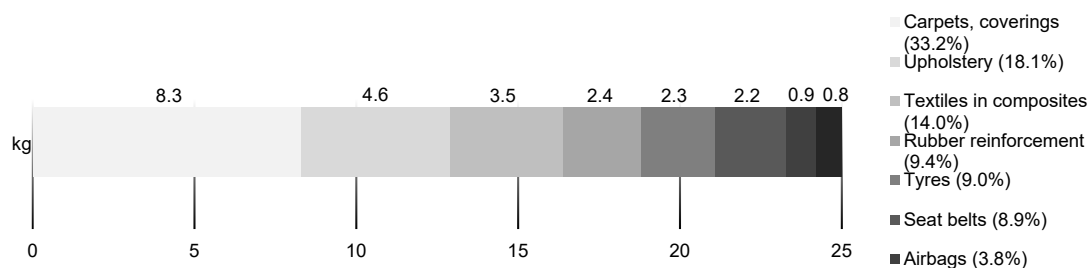

Figure 1. The share of textile materials for specific application in an average personal car

In this field of technical textiles, all types of textile products, fibres, yarns, nonwovens, woven fabrics, knitted fabrics and various types of composites are used. Materials with the specific application for car seat upholstery are consist of several layers, produced by different manufacturing technologies, forming a multifunctional product. All layers have almost equal importance, and in order to meet the high set demands on the properties of the finished product, the textile material must be considered as a whole. Compounding and fixing the component, results in a textile material that assumes the properties of all components, depending on their interaction. Designing a textile material does not always result in pre-planned and predetermined properties, despite good knowledge of the components individual properties. This indicates the influence of many different technological parameters of different production processes on textile material final properties [3].

Following the trends and considering market requirements, the materials become lighter, firmer, more resistant, more comfortable, more durable, suitable for different treatments, and also more accessible in different types and production process and methods, but also more environmentally friendly. Following the global ecological strategies, there is an increasing emphasis on the production and application of advanced textile materials with an ecological component, which will concurrently meet the high demand of the market. To support awareness and improvement in environmental conservation and recycling of all or just a part of transport vehicles, polyurethane (PU) foam, which is usually one of the components in the car seat cover, is increasingly being replaced with polyester (PES) or other fibres, in the various structures of textile fabrics [4].

Accordingly, this paper presents an analysis of such textile material used for automotive application, more specifically car seat upholstery. It is made of recyclable PES microfibers that are environmentally friendly and comply with the highest standards. The recycled polyester derives from polyester fibres (T-shirts, fibres) and PET (bottles, plastic). Recycling polyester means reducing energy consumption and CO<sub>2</sub> emissions into the atmosphere by 80% compared to the traditional petrol-based polyester production process. Product is 100% recyclable at the end of its useful life [5].

The subject of the research is a textile material composed of three layers: face, inner scrim and back, consisting of two components: woven and nonwoven fabric, constructed in the way that the face and backing of the textile material is nonwoven fabric, while the inner scrim is a woven fabric. The technological production process (Figure 2) of this textile material is extremely complex; nevertheless, eco-sustainability as well as the lowest levels of polluting emissions and energy consumption, is emphasized throughout the whole process [5].

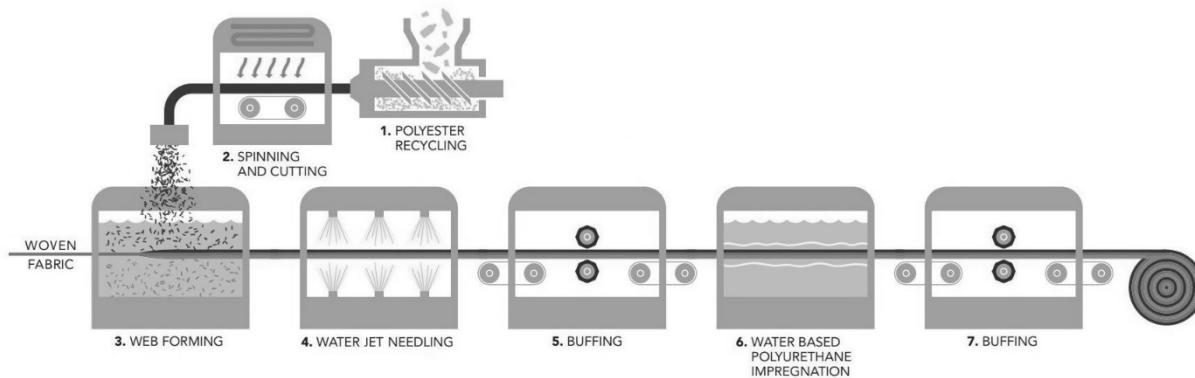

Figure 2. The technological production process of three-layer textile material consisting of two components - woven and non-woven fabric [5]

The technological production process consists of five main phases:

1. Polyester recycling and extrusion - For this process, polyester with a high viscosity melt is used.
2. Spinning and cutting - During the spinning process the fineness of filaments used for the composite face and backing is defined: face of the composite is composed of: 40% PES Microfiber (filament finesses 0.10 den), 40% PES Recycled Microfiber (filament finesses 0.15 den), 20% PES Microfiber (filament finesses 0.06 den); backing of the composite is composed of: 10% PES Recycled Microfiber (filament finesses 0.15 den), 90% PES FR filaments (Flame retardants filament finesses 0.5 den); for inner scrim woven fabric 100% PES yarn finesses 150 den is used.
3. Web forming - This process phase takes place in a "wet" state, where adhesive additives, which are formed through the polymerization process, are used to bind microfibers, forming the face and backing of the inner scrim. Used additives (based on latex - vinyl polymer, copolymer) must have low viscosity, in order to adequately bind the microfiber. The essence of material face and backing formation is based on the choice of filament fineness (which, depending on fineness, bind differently) and binders, where the low fineness filament bind to the face of inner scrim (woven fabric), while the rest is bound to the backside. The mycelization technique (feeding - breeding, binding) results in grouping shown in Figure 3:

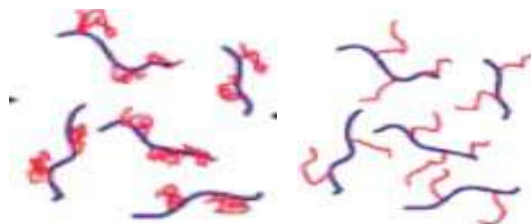

Figure 3. Grouping of filaments based on the mycelization technique

This point to the fact that 80% of the composite face is composed on an average filament finesses of 0.125 den (mass unit), while the composite backing is composed of 90% filament finesses 0.5 den. This is a significant difference, which explains the orientation of binding based on fineness and volume i.e. volume mass. After this phase, the fibrils are irregularly arranged on the face and backing of the material.

4. Water jet needling - In this phase the fibres additionally bond on the face and back of the inner scrim (woven fabric). Hydraulic nozzles (which dimensions are chosen based on the fibre fineness) are of crucial importance for the quality microfiber crosslinked, and the entire process has to be carried out at high pressure.
5. Buffing - After the web forming and water needling process, a semi-finished product is obtained which is necessary to buff. The material after the water needling has an uneven appearance and non-consistent physical properties and by buffing the face and backing, the material is further formed and strengthened.
6. Water based polyurethane impregnation - The microfiber is then immersed in a water polyurethane bath, which does not contain the solvents that are harmful to health and the environment. This process compacts the material, making it elastic and resistant (important parameters for achieving high quality materials for use in the automotive industry), which is achieved by the use of acrylate. Subsequently, the material passes through the thermal bonding process by hot air (through-air thermal bonding), which is also the drying process, resulting in material stabilization.
7. Buffing - The material finally passes through the additional buffing process, after which the material is ready for further processing steps [5].

The complex technological process of producing this kind of material results in the realization of a textile material with exceptional properties, essential for the automotive application, such as softness, pliant and low mass, while retaining the properties of strength, resistance and comfort.

## **EXPERIMENTAL**

### **Materials and Methods**

Investigation were carried out on the textile material composed of two components - woven and non-woven fabric, constructed in the way that the face and back of the fabric are constructed as nonwoven fabrics, while the inner scrim (interior) is constructed as woven fabric. The basic parameters of the woven fabric are: plain weave, fabric density - 25 threads/ 1 cm per warp and 20 threads/ 1 cm per weft; fabric mass per unit area - 332 g/m<sup>2</sup> and fabric thickness – 0.85 mm.

Three-layered textile material was analysed in order to investigate its physical-mechanical properties, morphology and surface composition. Analysis of advanced textile material for automotive application were performed by measuring:

- Breaking force and elongation at break in the warp and weft directions at dynamometer Statimat M - tt. Textechno
- Morphology examination and chemical analysis of textile material were conducted with FE scanning electron microscope (Mira, Tescan) and Quantax EDS (Bruker).

## RESULTS AND DISCUSSIONS

The measurements of breaking force and elongation at break of three-layered textile material are presented in Table 1 with coefficient of variation (%).

Table 1. Breaking force and elongation at break with coefficient of variation

Direction of fabric	Breaking force [N]	CV [%]	Elongation at break [%]	CV [%]
Warp	613.0	6.4	35.2	9.7
Weft	836.7	9.7	40.2	4.5

Breaking force and elongation at break of the composite material are higher in the weft direction of inner scrim - woven fabric (Table 1), regardless its density which is lower in comparison to the warp density. This can be explained by the influence of filaments size and the web forming on the face and the backing of the woven fabric, forming nonwoven layers, whose parameters affect the final properties of the composite material. Many variables, including nonwoven fabric process parameters (web forming process and bonding technique), affect the tensile properties. Fibre orientation has a big influence on the nonwoven fabric tensile properties, e.g. breaking force in machine direction (MD) and cross machine direction (CD).

Morphology of nonwoven face and back and woven inner scrim of the textile material are presented in Figure 4 and 5. As is already mentioned, these two layers are nonwovens and consisting of fibres that differ in fineness. Fibres from the face have diameter approx. 4  $\mu\text{m}$ , while fibres from the back are combination of fine and course fibres with diameter from approx. 4 to 10  $\mu\text{m}$ . Differences in fineness are mandatory because it affects not only on the softness and lower mass but also on the comfort properties. Increase of fibre fineness leads to increase of nonwoven porosity and air permeability [6]. The air imprisoned inside pores improves thermal resistance and creates thermal barrier. Figure 5.a show polyester fibres partially covered with adhesive additives, which in the same time affects surface roughness while in Figure 5.b fibres show smooth surface.

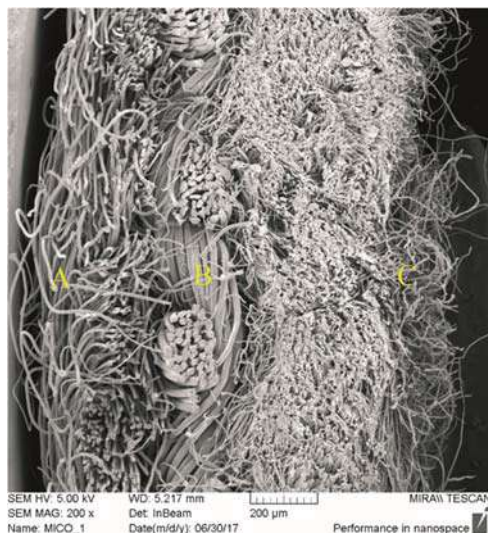
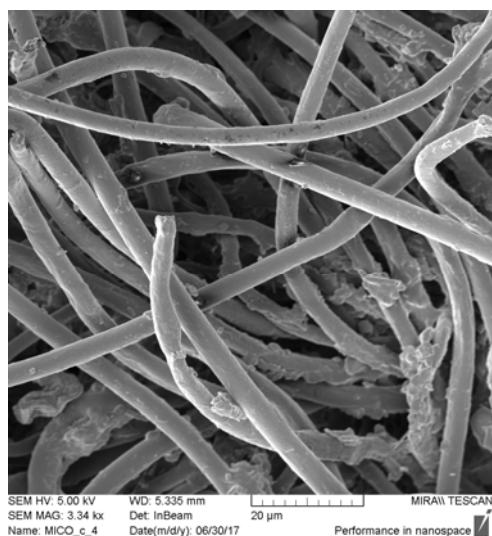
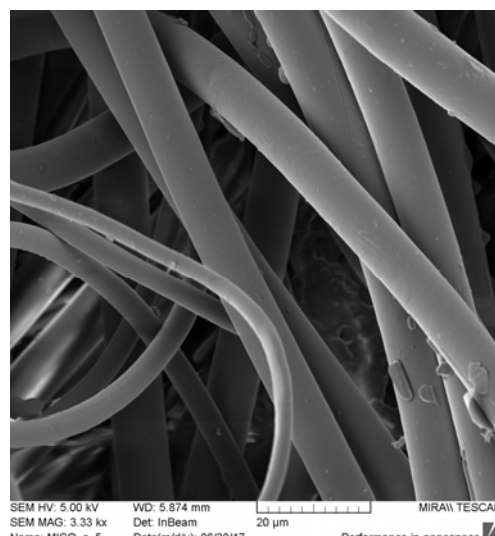

Figure 4. SEM image of cross section of investigated specimen: A – nonwoven back side, B – woven inner scrim, C – nonwoven face side



a)



b)

Figure 5. SEM images of a) face side and b) back side of the textile material that consists of PES fibres different fineness and surface roughness

Chemical (EDS) analysis of face and back side and inner scrim of the textile material (Figure 6, Table 2) points to the presence of polyester fibre (Carbon wt % is approx. 84-87% and oxygen wt % is 11-15%). Several possible interpretations of the nitrogen presence (wt. % is approx. 1 %), which is detected on the face side of the textile material, can be point out [7]:

- 15% block copolymers in the PES fibre may consist of amide group due to modification of final fibre properties e.g. elasticity (solid and soft copolymers)
- Pre-treatment of fibres with different agents for the purpose of improving the final properties of the textile material

- Adhesive bonding agents required for laminating samples, e.g. polyurethane foam. Chemical analysis of inner scrim showed an increase of the nitrogen content by 4 times, which indicates presence of adhesive bonding agents required for laminating samples, e.g. polyurethane foam.

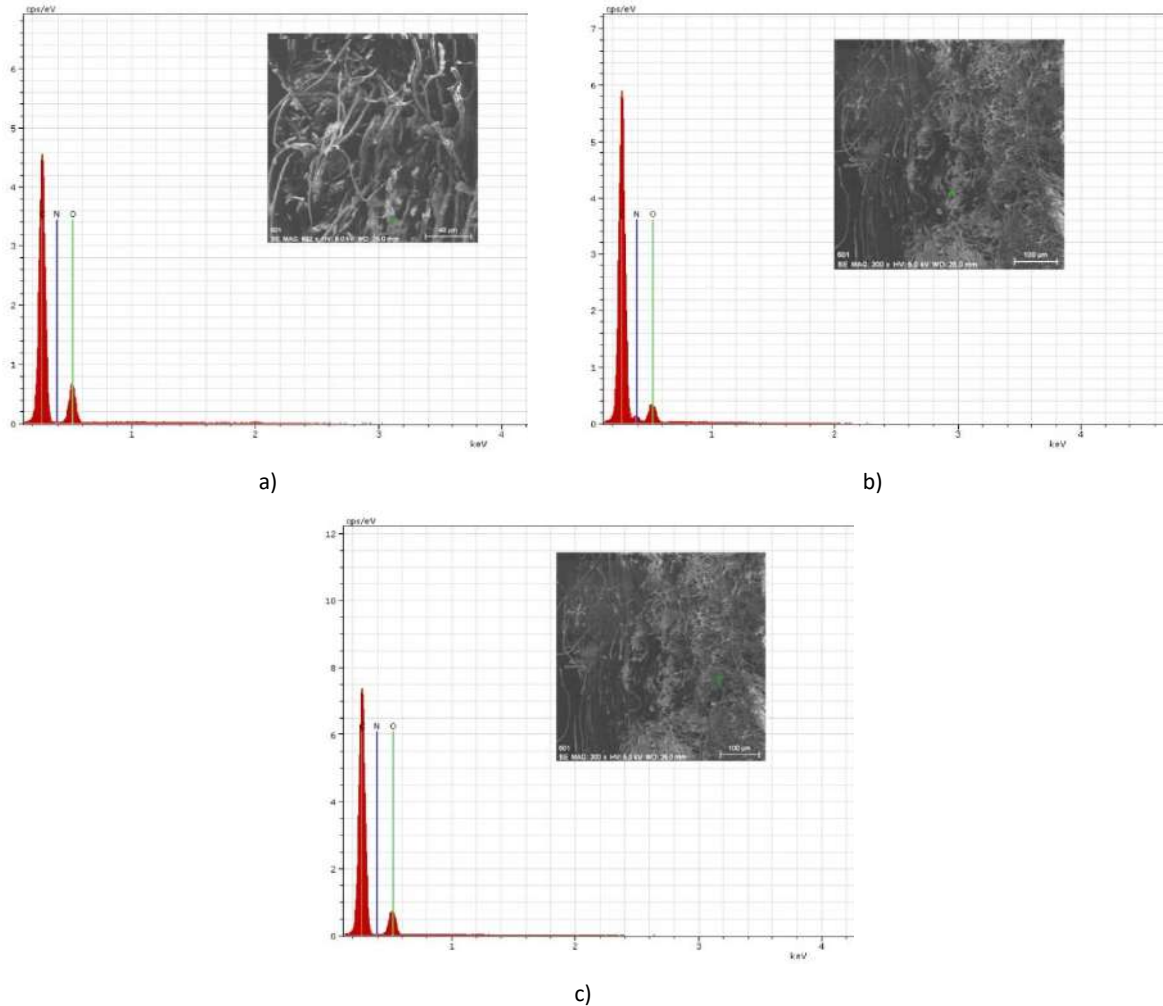

Figure 6. Graphical view of chemical analysis of the a) nonwoven face side, b) woven inner scrim and c) nonwoven back side



Table 2. Tabular view of chemical analysis of nonwoven face and back side and woven inner scrim

Sample	Element	AN	Series	Norm. wt. %	Norm. at. %	Error wt. %
Face side	Carbon	6	K	83.78	87.17	9.60
	Oxygen	8	K	14.79	11.56	2.04
	Nitrogen	7	K	1.43	1.27	0.42
Inner scrim	Carbon	6	K	87.10	89.40	9.51
	Oxygen	8	K	6.83	5.26	0.95
	Nitrogen	7	K	6.07	5.34	0.97
Back side	Carbon	6	K	87.38	90.07	9.56
	Oxygen	8	K	11.15	8.63	1.45
	Nitrogen	7	K	1.47	1.30	0.34

Designation: AN – atomic number; Series – energy level, electron shell; norm. wt. % - normalization by weight percentage; norm. at. % - normalization by atomic percentage, Error wt. % - percent error of weight percentage.

## CONCLUSIONS

The textile material used for automotive application i.e. for car seat upholstery was analysed in order to investigate its physical-mechanical properties, morphology and surface composition. It is necessary to point out that it is made of recyclable PES microfibers (from PES T-shirts; PET bottles and plastic) which was partially confirmed by chemical (EDS) analysis.

Breaking force and elongation at break of the composite material are higher in the weft direction regardless its density, which is lower in comparison to the warp density. Morphology of nonwoven face and back and woven inner scrim of the materials are consisting of fibres that differ in fineness which affects the softness and low mass, therefore also affects the comfort properties.

## Acknowledgements

This work has been fully supported by Croatian Science Foundation under the projects IP-2018-01-3170 Multifunctional woven composites for thermal protective clothing and 9967 Advanced textile materials by targeted surface modification.

## REFERENCES

- [1] Horrocks, A.R. & Anand, S.C.: *Handbook of Technical Textiles: Technical Textile Applications*, The Textile Institute, Woodhead Publishing, ISBN 978-1-78242-465-9, Cambridge, UK, (2016)
- [2] Kovačević, S.; Domjanić, J.; Brnada, S. & Schwarz, I.: *Textile Composites for Seat Upholstery, Textiles for Advanced Applications*, In Tech, ISBN 978-953-51-3501-2, UK, (2017), pp. 191-210
- [3] Kovačević, S.; Ujević, D.; Schwarz, I.; Brlobašić Šajatović, B. & Brnada, S.: *Analysis of Motor Vehicle Fabrics, Fibres & Textiles in Eastern Europe*, 71 (2009), pp. 32-38, ISSN 1230-3666

- [4] Fung, W. & Hardcastle, M.: *Textiles in automotive engineering*, Woodhead Publishing, ISBN 1-85573-493-1, Cambridge, UK, (2001)
- [5] *Dinamica Miko*: <https://dynamkamiko.com/> Accessed: 2018-06-18
- [6] Das, D.; Ishtiaque, S.M. & Das, S.: Influence of fibre cross-sectional shape on air permeability of nonwovens, *Fibers Polymer* 16 (2015) 79, <https://doi.org/10.1007/s12221-015-0079-9>, Accessed: 2018-12-28
- [7] Mamtaz, H. et al.: Acoustic absorption of natural fiber composites, *Journal of Engineering* (2016), <http://dx.doi.org/10.1155/2016/5836107>, Accessed: 2018-12-28

## DIFFICULTIES IN TABLE LINENS PRODUCTION PROCESS

**Snježana BRNADA<sup>1\*</sup>, Ivana SCHWARZ<sup>1</sup>, Tanja PUŠIĆ<sup>1</sup>, Stana KOVAČEVIĆ<sup>1</sup>, Irena VALEK<sup>2</sup>**

<sup>1</sup>University of Zagreb Faculty of Textile Technology, Prilaz baruna Filipovića 28a, 10000 Zagreb, Croatia, \*email: sbrnada@ttf.hr

<sup>2</sup>Tvornica tekstila Trgovišće d.o.o., Dr. Stanka Pinjuha16, Veliko Trgovišće

---

### ABSTRACT

*Weaving of table linens (table covers, decorative tablecloths and napkins) on large width weaving machines in a form of multiple tapes, weft cutting and selvedge forming on the edge of tapes are common and effective way of their production. However, the process of chemical finishing (desizing, bleaching, dyeing, mercerising, etc.) requires larger fabric widths, meaning that the napkins and table cloth have to be stitched back together after weaving in order to obtain the appropriate width corresponding to the working width of the finishing machines. Uneven thread tension in the seam, as well as inner fabric tension, and exposure to chemical agents, in wet and dry conditions, with various temperature conditions, can affect the thread in a seam and cause the seam damage. According to the obtained results, it is apparent that the thread from the seams has a lower tensile stiffness compared to the thread that is treated in the same way in finishing processes and to the thread from the cross-wound cone. The tensile stiffness of the sewing thread decreases mostly after the bleaching process. By visual inspection, it was found that the sewing thread damage was very localized and by marking these points prior tensile testing, it is found that the thread breakpoints where on exact places.*

### KEYWORDS

*table linens, weaving, chemical finishing, thread, sewing seam*

---

### INTRODUCTION

Tablecloths (table covers, decorative tablecloths and napkins) require complex preparation of warp, weaving and chemical finishing [1]. Since these fabrics are often more narrow than the working width of the machine, they are usually woven in strips with different combinations, or different widths of strips, to utilize the working width of the machine [2, 3].

Complexity of warp preparation stands for production of two or more warp beams being placed on one machine [4]. The warp is often multicolored, relatively dense, cotton, ply or single yarn, which is also sized. Weaving machines are usually jacquard or dobby, indicating the complexity of the warp thread draw-in, instalation of additional end-forming devices (two strips require four end-forming devices, three strips require six end-forming devices, etc.), multi-strips weaving, frequent tension control piecwise and in the ends [5]. For these fabrics, the most commonly used ends are tucked-in ends which tend to increase the tension of the warp threads due to the thickening of the fabric resulting in double density of the weft [6]. The consequence of this is a higher values of warp crimp in the woven ends, and hence a greater tension, which causes breaks in the production and the

inadequate appearance of the ends. Listed problems could be reduced with the usage of appropriate weave, but not completely. When winding the fabric on the cloth beam, on the places of fabric end there is the larger diameter on the beam, due to their greater thickness of the ends comparing to the fabric base. The effect of growing diameter is more pronounced with the winding. This results in an even higher tension of the warp in the fabric ends, limiting the cloth roller capacity.

When joining the fabric strips after weaving, and prior to the chemical finishing, it is important to use the same thread and the same sewing conditions (thread tension, sewing speed, needle type, length of seam) so that fabric tension at the ends stays the same throughout the chemical finishing process [7, 8]. Otherwise, there is a risk of uneven tensile strength of the stripes during the chemical finishing process which would lead to tightening in the seam and damage. In order to detect the cause of occasional damage of the sewing thread, extensive research on finished woven fabric has been carried out.

The aim of this paper is to investigate the changes of various properties of the sewing thread that joins woven fabrics in length. Strength loss of the thread in the sewing seam may occur due to the wet processing by various means, or to the excessive tension of the fabric and its deviation in the joined ends.

## **EXPERIMENTAL**

The tests were carried out on the cotton table cloth in Trgovišće Textile Factory (TTT). The mechanical properties of the yarn, ie the sewing thread with which the strips of table cloth were joined, before and after the chemical finishing were examined. After the chemical finishing, the tests were carried out on the random sections of the joined strips where the thread remained firm and on the sections where damage was noticeable. To determine the damage of the thread during chemical finishing, the tests were carried out after the mercerizing and bleaching. Sewing thread damage in fabric ends after the finishing process in the finishing mill and damage of the sewing thread after mercerisation and bleaching performed in the laboratory has been compared.

### **Materials and Methods**

Thread Test Procedure:

- from the spool before sewing
- after chemical treatment on joining sections with a satisfactory strength
- after chemical treatment on joining sections with a unsatisfactory strength
- After mercerization and neutralization, carried out in the Unitas textile factory laboratory (sl. 1a),

- After bleaching, carried out in the Unitas textile factory lab (sl.1b).

Mechanical and breaking properties of all samples were performed on the tensile tester.

## RESULTS AND DISCUSSIONS

The appearance of the sewing thread before and after the chemical finishing, after mercerization and neutralization and after bleaching was observed under the enlargement of the Dino Lite microscope and shown in Figures 1-4.

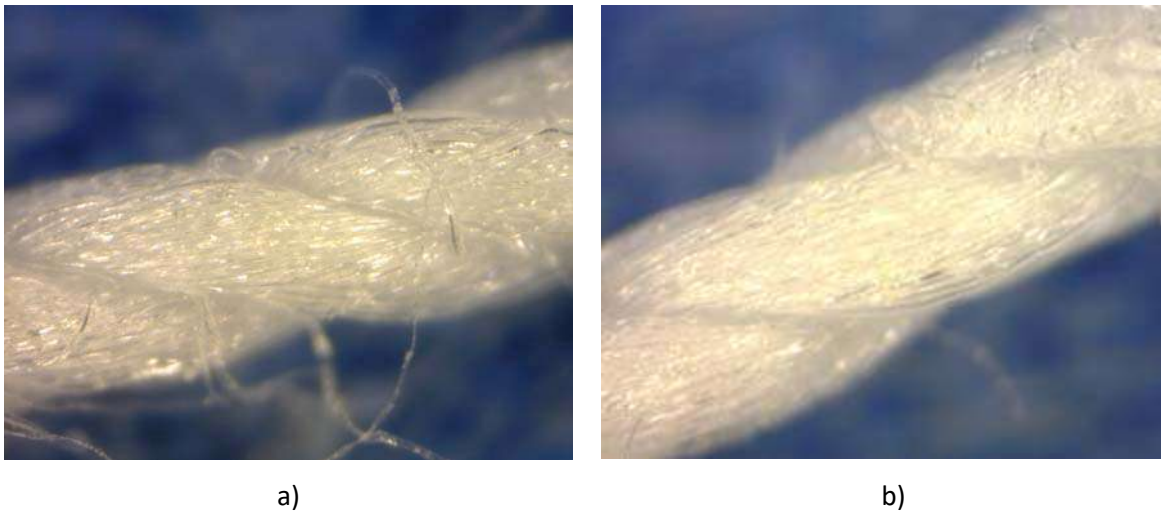

Figure 1. Sewing thread; a) After mercerization, b) After bleaching

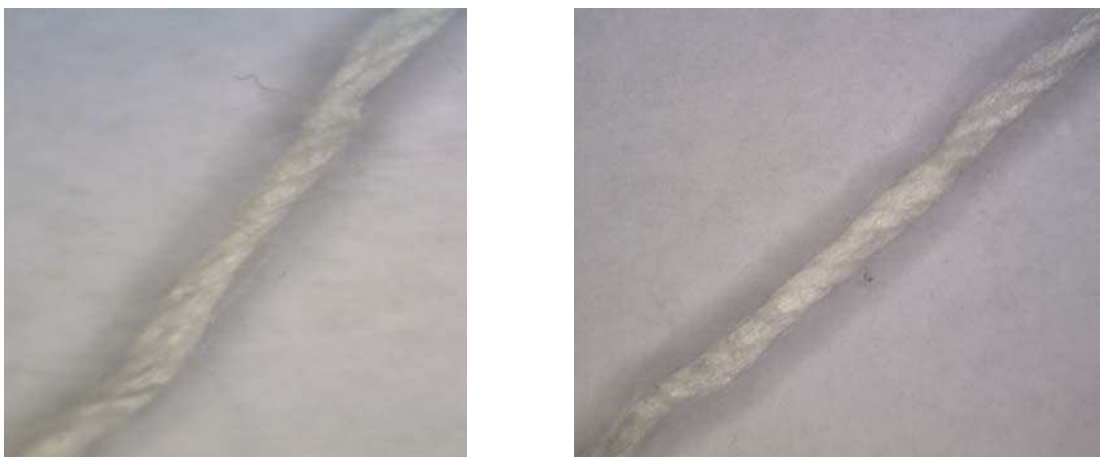

Figure 2. Sewing thread without any major damage after separation from the fabric



Figure 3. Sewing thread that has suffered major damage after separation from the fabric

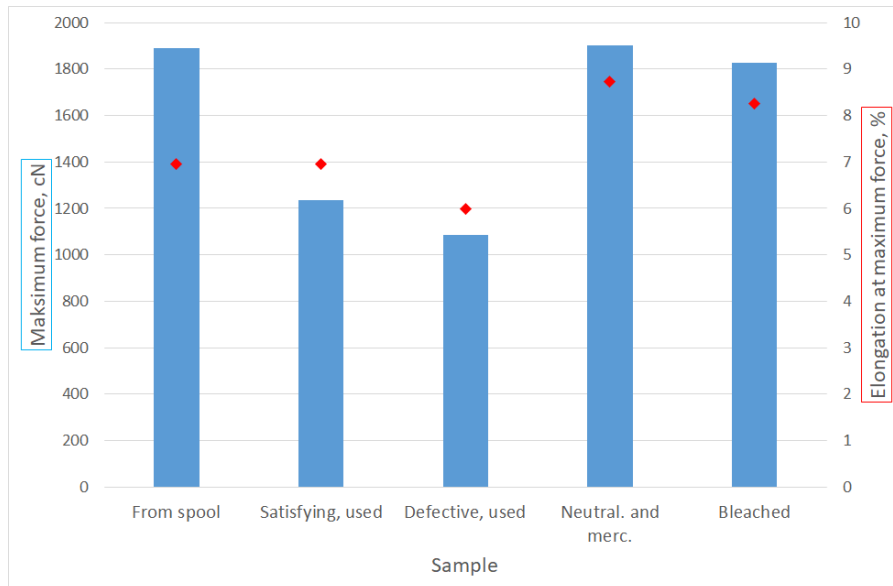

Figure 4. Breaking properties of the sewing thread

Figure 4 shows that the decrease of the maximum force in relation to the initial state (the yarn from the spool) is smaller for the yarn that has passed the process of neutralization, mercerisation and bleaching in the laboratory in a relaxed state than in yarns that have passed all these processes in form of the sewing seam that joined two woven strips together. Elongation at the maximum force is the lowest at the sewing thread that had the greatest deformation. Tensile stiffness is apparent from the diagram (Fig. 5). In this figure (elongation-force diagram) it can be noticed that the inclination of the approximate curves for the threads used for sewing is smaller than the yarns that had gone through finishing processes in the tendril form. Modules are reduced, meaning that the yarns from the seams have lower tensile stiffness compared to the yarns finished in yarn tendril form and the initial from the spool. From the graph it is apparent that the tensile stiffness decreases with bleaching.

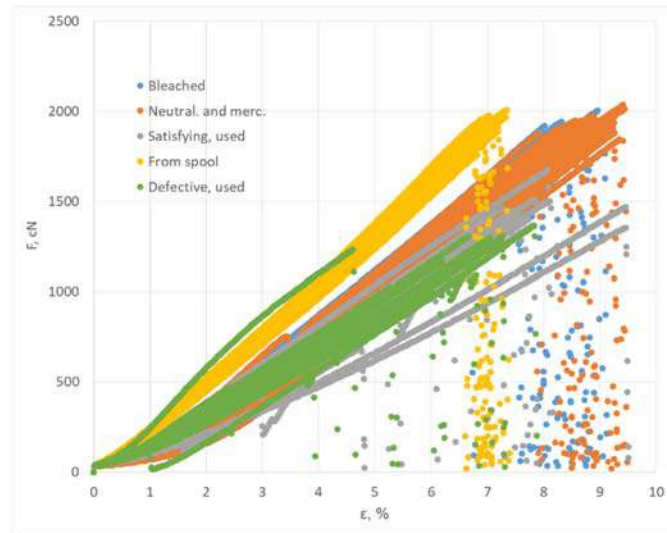

Figure 5. Diagram, breaking force (F/cN) – elongation at break (%)

Table 1. Statistical values of the mechanical properties of the sewing thread

	Elongation (Fmax), %	Maximum force, cN	Tenacity, cN/tex	Time to rupture, sec	Work to break, Ncm
<b>Average</b>					
Satisfying, used	6,95	1233,81	18,69	4,23	21,97
Defective, used	5,98	1083,68	16,42	3,69	16,19
From spool	6,95	1888,45	28,61	4,23	31,78
Neutral. and merc.	8,73	1899,97	28,79	5,48	38,08
Bleached	8,26	1825,31	27,66	5,17	33,95
<b>Standard deviation</b>					
Satisfying, used	1,80	349,12	5,29	1,09	8,65
Defective, used	1,38	256,59	3,89	0,84	6,09
From spool	0,17	56,67	0,86	0,1	1,66
Neutral. and merc.	0,42	64,03	0,97	0,27	2,72
Bleached	0,51	95,35	1,44	0,33	3,36
<b>Coefficient of variation</b>					
Satisfying, used	25,87	28,3	28,3	25,68	39,38
Defective, used	23,12	23,68	23,68	22,82	37,62
From spool	2,42	3,00	3,00	2,43	5,23
Neutral. and merc.	4,79	3,37	3,37	4,86	7,14
Bleached	6,15	5,22	5,22	6,36	9,88

The results of the sewing thread testing after the chemical finishing process are shown in Figures 1-5, and in tab. 1.

According to the results obtained (Table 1) it can be seen that the breaking force of the thread was significantly reduced after the chemical treatment in the finishing process, especially on the sections where the seam did not withstand the strength. The coefficient of variation and standard deviation are considerably higher for the sewing thread from the stitch comparing to the same thread treated in the laboratory.

Regardless of the reduced number of tested samples, differences in variability parameters indicate the variability of mechanical properties. There is a clear inconsistency of the breaking characteristics (maximum force and elongation at maximum force) resulting from unevenly distributed damage. The assumption is that the yarn damage are higher and very localized on the yarn joints (caused by geometry or stitch). This indicates local mechanical damage of yarn.

## CONCLUSIONS

The significance of this research is to find the optimum sewing conditions so that the thread tension, or its consumption, stays uniform during sewing. Respecting the use of the same raw material for fabric and thread, in this case cotton, it is extremely important to choose a thread that will meet the required physical-mechanical properties to guarantee minimal seam damage during chemical finishing.

By visual inspection, no damage was found in the structure, created by neutralization, mercerization and bleaching, performed in the laboratory at a relaxed state of the sewing thread, but the mechanical properties have decreased.

The sewing thread separated from the seam that has joined the fabric strips, after the chemical finishing, shows certain changes that are characterized by thread deformation as well as changes in mechanical properties on the satisfying and defective seam sections.

Significant thread damage occurred on segments of sewing seam which did not retain the required strength. Damage are localized at the points of change of the thread direction in the seam, which are also the places of the greatest strain. Precisely those places are responsible for the thread break.

Breaking properties of the sewing thread and after the chemical treatment in the laboratory and the finishing process are significantly different. During the process of mercerisation and bleaching in the laboratory, the thread was less damaged than the one that went through the finishing process in the seam form. Variation of the breaking properties is much greater at the sewing thread from the seam compared to the other tested threads.



Finally, it can be concluded that wet finishing of woven fabric, such as mercerizing and bleaching, contributes to the deformation of the thread in the seam which joins woven strips, due to the treatment with chemical agents, wet / dry conditions, high temperature, tension and its uneven consumption.

### **Acknowledgements**

This work has been fully supported by the Croatian Science Foundation under the project number IP-2018-01-3170

### **REFERENCES**

- [1] H.-K. Rouette, B. Schwager, *Encyclopedia of textile finishing*, vol. 20. Springer Berlin, 2001.
- [2] S. M. Giovanni Castelli, *Reference Books of Textile Technologies - Weaving*. Milan: Association of Textile Machinery Producers Moral Body, 2000.
- [3] S. Kovačević, K. Dimitrovski, J. Hađina, *Procesi tkanja*. Tekstilno-tehnološki fakultet, 2008.
- [4] S. Kovačević, *Priprema pređe*. Zagreb: Faculty of Textile Technology, University of Zagreb, Zagreb, 2002.
- [5] A. R. Horrocks, S. C. Anand, *Handbook of technical textiles*. Elsevier, 2000.
- [6] S. Kovacevic, S. Brnada, I. Schwarz, S. Kovačević, S. Brnada, I. Schwarz, Analysis and optimization of tucked-in selvages, *Tekstil*, vol. 56, no. 8, 2007., str. 486–492.
- [7] I. Jones, G. K. Stylios, *Joining textiles: principles and applications*. Elsevier, 2013.
- [8] B. Rogina-Car, S. Kovačević, S. Brnada, I. G. Schwarz, Mechanical Properties of Fabrics in the Directions of the Seam, in *12th Autex World Textile Conference*, 2012.

# EQUIVALENT AVERAGE DIAMETER OF PORES - DEFINITION AND DETERMINATION

Krste DIMITROVSKI<sup>1\*</sup>

<sup>1</sup>University of Ljubljana, Faculty for Natural Sciences and Engineering, Department of Textiles, Graphic arts and Design, Snežniška 5, 1000 Ljubljana, Republic of Slovenia, \*email: krste.dimitrovski@gmail.com

---

## ABSTRACT

*Beside geometrical and optical, there are several other methods for determining porosity parameters as are: mercury intrusion, liquid extrusion, fluid flow methods. All of them are using some liquid material to be intruded in, or extruded from previously saturated fabric. From the connection between surface tension of used liquid and used pressure for its intrusion/extrusion is calculated the size and distribution of pores. As is obvious from the number of methods, no one is giving full range satisfactorily results. That because of measuring principle and measuring condition adapted for the primary measured parameter necessary for the purpose in use. Almost in all cases it is the size of pores but not always the same parameter of pores that could be the volume, the diameter or the throat of pores their minimal, maximal, average value and its distribution. The structure of pores in woven fabrics is complex and different which make them difficult to be described. For that reason, many researches are treating them as cylinders with certain constant diameters and length equivalent to the fabric thickness. The definition of equivalent average pore diameter is such diameter of cylindrical pores structure with known number of pores that allows the same air permeability as real woven fabric sample with the same number of pores and thickness. This is the basis of the new approach to the problem which gives the connection between equivalent average pore diameter and air permeability. Equivalent pore diameter is a new introduced variable which takes in account not only diameter of pore but also all its internal structure like direction, walls of pores, throat, tortuosity, etc.*

## KEYWORDS

*Attributes of pores, determination, air permeability*

---

## INTRODUCTION

Air permeability is one of the important parameters of woven fabrics contributing to different practical application as clothing fabrics or technical fabrics (e.g. filtration, drying processes). It is the function of, so called, porosity parameters which are: the number, size and distribution of pores in the woven fabrics structure. Beside geometrical [1] and optical [2], there are several other methods for determining porosity parameters as are: mercury intrusion [3], liquid extrusion [4], fluid flow [5, 6, 7] methods. All of them are using some liquid material to be intruded in, or extruded from previously saturated fabric [2, 3, 4]. From the connection between surface tension of used liquid and used pressure for its intrusion/extrusion is calculated the size and distribution of pores. As is obvious from the number of methods, no one is giving full range satisfactorily results. That is because of the measuring principle and measuring condition adapted for the primary measured parameter necessary for the purpose in use.

In almost all cases, the size of pores is relevant parameter, but not always. The other important parameters describing pores are also the volume, the diameter or the throat of pores, their minimal, maximal or average value and its distribution. The structure of pores in woven fabrics is complex and different which make them difficult to be described. For that reason, many researches are treating them as cylinders with certain constant diameters and length equivalent to the fabric thickness. The definition of equivalent average pore diameter is such diameter of cylindrical pores structure with known number that allows the same air permeability as real woven fabric sample with the same number of pores. This is the basis of our approach to the problem which gives us the connection between equivalent average pore diameter and air permeability. Equivalent pore diameter is a new introduced variable which takes in account not only diameter of pore but also all its internal structure like direction, walls of pores, throat, tortuosity. It can be obvious from the set of open woven fabrics in same warp and weft densities but in plain and 2/2 twill weave. Geometrically the size and consequently diameter of pores should be the same but, because the different type of pores the air permeability of fabrics in twill weave will be, depending on densities, up to 20 % higher. Equivalent average pore diameter calculated from the air permeability measurements should show about 20 % bigger diameter.

## THEORRETICAL ANALYSIS

As basis for development of model for determining average equivalent diameter of pores we used some facts of planar, geometrical presentation of one-layer woven fabric structures and some facts from fluid mechanics that describe the nature of flow through the fabrics.

### Pore structure of woven fabrics

There are four types of pore in one-layer woven fabrics. Depending on weave one woven fabric can consists of only one (plain and twill 2/2), two types of pores (twill 1/2), three types of pores (twill 1/3) or sometimes even four types of pores. The pores are rectangular shape and differ in dimensions, texture of pores walls, length and positioning of their bottle neck. Planar structure of pores presented in Figure 1b, does not take in account the third dimension of pores, but allow calculation of hydraulic diameter of pores that transfer the two dimensions (length and width) of rectangular pores to only one (diameter) of cylindrical shape according to equation (1).

$$D = 2 \times a \times b / (a + b) \quad (1)$$

Where: a – the width and b – the length of rectangular pores.

It simplifies presentation of pores and makes it closer to prediction of some permeability properties (air permeability). The biggest disadvantage of such defined hydraulic diameter of pores is

that with the same constructional parameters in woven fabric construction (fineness of yarns and densities) always gave the same resulting value no matter what kind of pore are in the woven structure.

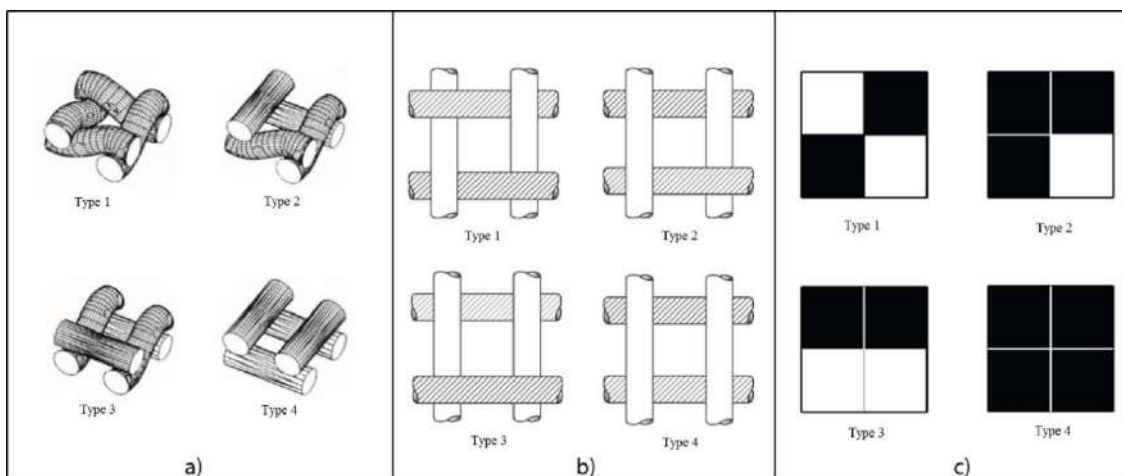

Figure 1. Four types of pores in woven fabrics showed three-dimensionally (a), in a planar way (b), and on the weaving paper (c) [8].

The lack of the third-dimension properties of pores does not allow direct accurate connection between hydraulic diameter of pores and air permeability. There is need for other variable to be included in equation for more precise prediction of air permeability. In previous work we used for that, beside number of pores on square area the total porosity of woven fabric as compensation for missing data of third dimensions. The three variables were chosen because they can be determined easily from the primary constructional parameters and physical properties of woven fabrics: theoretical diameter of yarns, the density of yarns and thickness and mass per square meter from which the total porosity is calculated. Linear combination of all three variables covers large amount of accurate prediction of air permeability of woven fabrics (2), (3).

$$Q = F(d_h, n, \varepsilon) \quad (2)$$

$$Q = k_1 \times d_h \pm k_2 \times n \pm k_3 \times \varepsilon \quad (3)$$

Where:  $d_h$  – hydraulic diameter of pores;  $n$  – number of pores in square area,  $\varepsilon$  – the total porosity of woven fabric and  $k_1$ ,  $k_2$  and  $k_3$  – coefficients.

A research published in TRJ in 1951 [8] showed that according to the type of pore, shown in Fig. 1 the cross section of different pore types differs significantly. The results of their research are showed in Fig. 2 and 3.

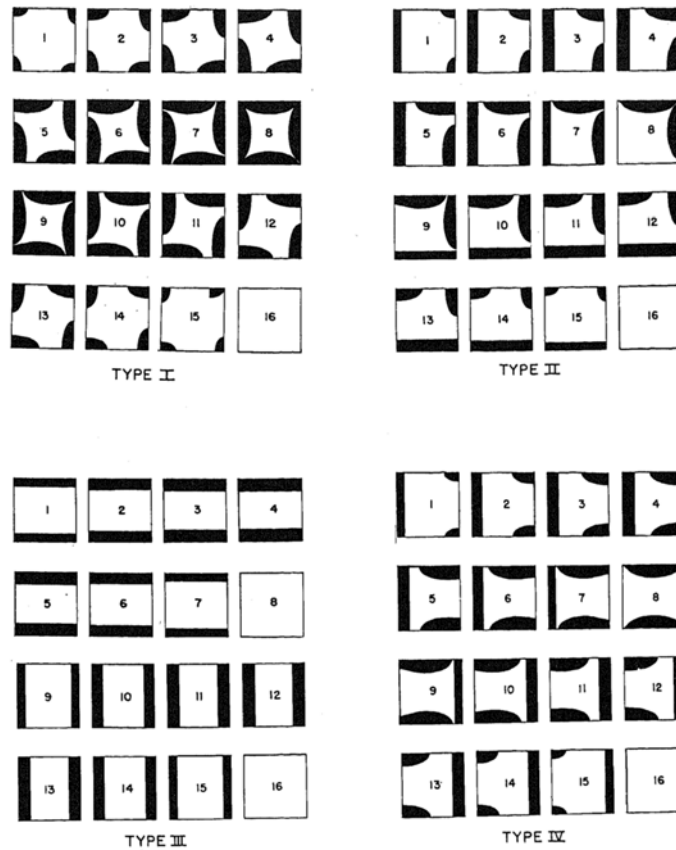

Figure 2. The deformation - changes of different type pores cross section with the thickness [8].

They prepared model of cell unit as augmented cell. The diameter of yarn was 0.0508 m and the spacing 0.127 m made the cross sections of 16 layers (meaning every 1/8 of yarn diameter) and photographed it. After statistical analysis they determined the portion of yarn and open area on every layer of cross section through the thickness of unit cell. Then they diminish taken pictures to the level of real fabric i.e. Yarn diameter of 0.004 inches (about 256 micrometres) and spacing 1/density= 0.000254 m which correspond to 100 yarn per 0.0254 m.

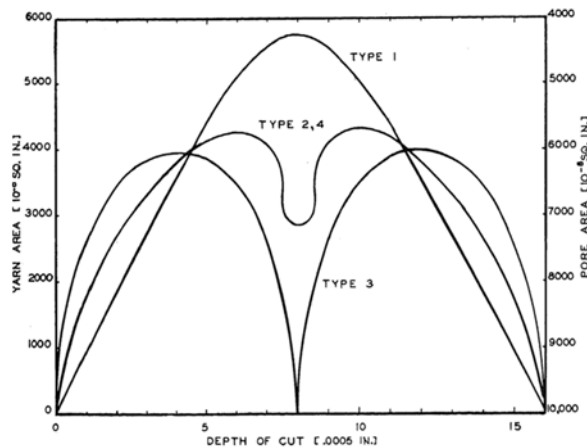

Figure 3: Portions of cross- sectional area of yarns and open void through the thickness of unit cells [8].

From the Figures 2 and 3 is obvious that cross sections of pores in plain weave are smaller than pores in twill or basket weaves, which coincides with the results of measured air permeability.

### Theory of fluids flow

There are two types of flow in fluid mechanics theory - laminar and turbulent. Laminar flow is linear function of pressure drop and turbulent power function of pressure drop with exponent lower than 1. The nature of flow in circular tubes is defined by so called Reynolds number. For Laminar flow Reynolds number must be lower or equal to 2200.

$$Re = (v + d)/\vartheta \quad (4)$$

where:  $v$  is the fluid velocity (m/s),  $d$  is the diameter of tube (m) and  $\vartheta$  dynamic coefficient of viscosity ( $m^2/s$ ).

Exact solution of fluids flow through circular tubes in the range of laminar flow is giving Hagen-Poiseuille equation

$$Q = \frac{\pi \cdot d^4 \cdot n \cdot \Delta p}{128 \cdot \mu \cdot l} = A \cdot \Delta p \quad (5)$$

Where:  $Q$  – volume flow rate ( $cm^3/s$ ,  $cm^2$ ),  $d$  – diameter of pores (cm),  $n$  – number of pores,  $\mu$  – kinematic coefficient of viscosity (Pas) in our case  $1.8369 \cdot 10^{-5}$ ,  $l$  – thickness of fabric/length of pores (cm) and  $\Delta p$  – pressure drop (Pa).

### Development of idea for determining average equivalent pore diameter in woven fabric

From the equation (5) is evident that if someone succeed to keep the flow through woven fabric in the range of laminar flow using very low pressure, from the very few measured pars of fluid flow - pressure can identify the coefficient  $A$  and from its value when number of pores  $n$  is known can calculate equivalent average diameter of pores according to equation (6).

$$d_e = \sqrt[4]{\frac{128 \cdot A \cdot \mu \cdot l}{\pi \cdot n}} \quad (6)$$

## EXPERIMENTAL

### Materials and Methods

To check theory we provided measurements on the set of referential samples. The samples were chosen among real cotton fabrics in three basic weaves plain, twill 2/2 and satin 1/4. The weaves were chosen intentionally since plain and twill 2/2 weaves have only one type of pores (pore type 1 and 2) and satin 1/4 have in its structure 2 types of pores (20% type 2 and 80% type 4). On the other hand the weaves differ in floating length which participate to their thickness and consequently to three dimensionality of pores. The samples were made from the same yarns counts – 36 tex in warp and

weft an with the same set densities 24 ens, picks/cm. Consequently they had the same number of macro pores – 576 inter yarn pores. They differ in weave, thickness and porosity as well in air permeability. This is evident from Table 1 where relevant physical parameters of investigated woven fabrics are given.

Table 1. Construction parameters of examined woven fabrics

Sample	Fabric thickness (mm)	Fabric mass (g/m <sup>2</sup> )	Fabric porosity (%)
Plain	0.35	186.7	65.8
Twill 2/2	0.40	182.3	70.8
Satin 1/4	0.45	177.1	74.7

As a method we were using newly developed method for determination equivalent average pore diameter based on measurement of air flow under low pressure drops and equation (6). All measurements were provided on AIRTRONIC 4567 air permeability tester – Mesdan supplier. Actually, electronic testing machine AIRTRONIC 4567 air permeability tester upgraded its software for immediate calculation of equivalent average diameter of pores that is showed on the tester screen. That makes it very suitable for daily use for getting fast results – in a very few minutes, without almost any previous preparations.

## RESULTS AND DISCUSSIONS

Figure 4 is giving results of air permeability measurements trough investigated samples and table 2 calculated results with the use of equation (6).

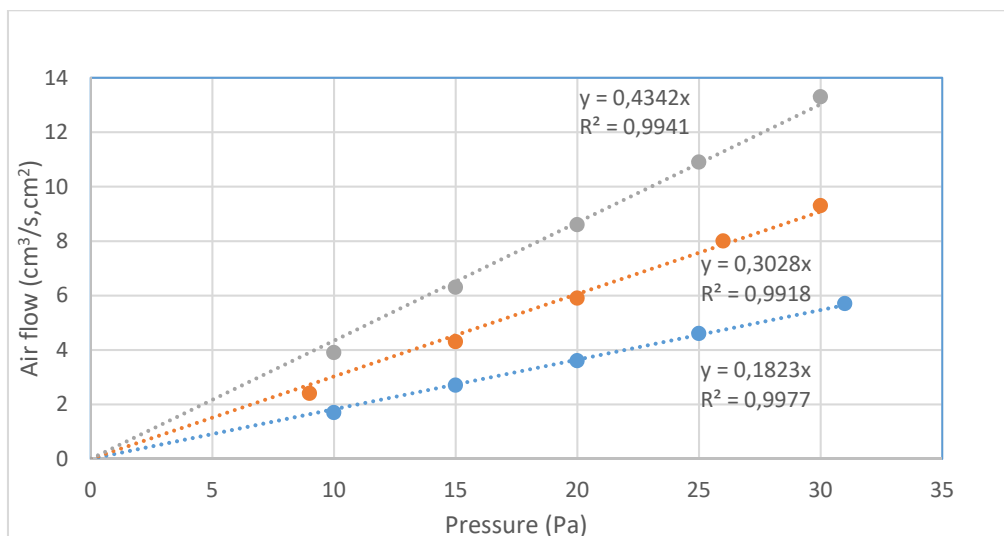

Figure 4: Measured values of pressure -air flow pairs and demonstration of linearity with proper equations and coefficient of determination (blue- plain; yellow -twill 2/2; grey – satin 1/4)

Table 2. Coefficient of regression A, coefficient of determination R<sup>2</sup> and calculated average pore diameter of samples d

Sample	Coefficient of regression A	Coefficient of determination	Equivalent average diameter of pores ( $\mu\text{m}$ )
Plain	0.1823	0.9977	95.39
Twill 2/2	0.3028	0.9918	111.57
Satin 1/4	0.4342	0.9941	126.23

From the Figure 4 and Table 2 is obvious that woven fabric in plain weave has the smallest air permeability and smallest calculated equivalent average diameter of pores. It is followed by fabric in twill weave which has 16.9 % bigger equivalent average diameter and satin weave which has 35.3 % bigger diameter comparing to the fabric in plain weave. It coincides very well with the data presented in Table 1 regarding the thickness and porosity of fabrics.

## CONCLUSIONS

The most important is that the newly developed parameter of characterization of woven fabrics extend already present parameters and fulfil the palette that give the possibility to evaluate different characteristics for everyday use from the different angle. It is especially well connected with air permeability properties and can be used in prediction of woven fabrics properties in dry, wet filtration and drying processes.

It is also important that already exists the electronically supported test machines and method, which allow fast and accurate determination of equivalent pore diameters with numerous advantages as are:

- It is the only method where average diameter of pores is calculated from the air permeability;
- Method is extremely fast – takes only few minutes;
- Method is non-destructive – contrary to other methods you do not need any preparation and cutting of samples;
- Method can be used for optically non-transparent fabrics;
- Method is valid for all woven and knit fabrics with known number of macro pores (pores between the threads);
- Method gives more accurate results regarding used energy (pressure drop) for certain air flow than geometrical and optical methods.



### **Acknowledgements**

Many thanks to companies Idealair, Via Torino, 583/6, 21020 Mercallo VA Italy and particularly Mesdan S.p.a Via Masserino 6, 25080 Puegnago (BS) Italy for their contribution in research and preparing this paper.

### **REFERENCES**

- [1] Zupin Ž, Hladnik A, Dimitrovski K, Prediction of one-layer woven fabrics air permeability using porosity parameters. *Text. Res. J.* 2012; 82: 117-128
- [2] Algaba I, Riva A, Crews P, Influence of fiber type and fabric porosity on the UPF of summer fabrics. *AATCC Rev.* 2004; 4: 26-31
- [3] Paul A W, An Introduction To The Physical Characterization of Materials by Mercury Intrusion Porosimetry with Emphasis On Reduction And Presentation of Experimental Data Micromeritics Instrument Corp, 2001, [http://www.webmail.micromeritics.com/Repository/Files/An\\_Introduction\\_To\\_The\\_Physical\\_Characterization\\_of\\_Materials\\_by\\_Mercury.pdf](http://www.webmail.micromeritics.com/Repository/Files/An_Introduction_To_The_Physical_Characterization_of_Materials_by_Mercury.pdf) (accessed 13 January 2017).
- [4] Miller B, Tyomkin I, Pore Size Distributions from Measurements of Liquid Uptake and Retention Proceedings, 11<sup>th</sup> INDA Technical Symposium on Nonwoven Technology, 1983; 73-82
- [5] Jena A, Gupta K, Pore volume of nanofiber nonwovens, *Porous Materials Inc.* 2003;12: 45-53
- [6] Scheidegger A E, The physics of flow through porous media, Ed. University of Toronto Press, Toronto, 1963; 75
- [7] Jakšić D, Jakšić N, Assessment of Porosity of Flat Textile Fabrics. *Text. Res. J.* 2007; 77: 105-110
- [8] Backer S, The relationship between the structural geometry of textile fabric and its physical properties, Part IV: Interstice geometry and air permeability. *Tex. Res. J.* 1951; 703-714

# AN INTRODUCTORY COMPUTATIONAL DEFORMATIONAL MODEL OF LIMB-SOCK INTERACTION

Željko ŠOMOĐI<sup>1\*</sup>, Željka PAVLOVIĆ<sup>1</sup>, Emilija ZDRAVEVA<sup>1</sup>, Zlatko VRLJIČAK<sup>1</sup>

<sup>1</sup>University of Zagreb Faculty of Textile Technology, Prilaz baruna Filipovića 28a, 10000 Zagreb, Croatia, \*email: zeljko.somodi@ttf.hr

---

## ABSTRACT

*Tight elastic clothing items are frequent in general but also play an important role in sports equipment and medical applications. A proper choice of geometry and mechanical properties is essential for good balance between function and comfort. In an appropriate engineering analysis the deformational properties of both body tissue and elastic sock need to be accounted for. The limb is considered here as a composite cylinder consisting of concentric thick walled tube with rigid core. It is loaded by the pressure resulting from the tightly applied cylindrical membrane representing sock or compressive bandage. Linear elastic deformation is considered in all materials involved. The results are given in the form of diagrams of stress distribution in the cylinder. Examples indicate the influence of geometry and material properties to the stress state in the tissue.*

## KEYWORDS

*Elastic sock, limb, cylindrical membrane, composite cylinder, stress state, computational model*

---

## INTRODUCTION

Tight elastic clothing that provide adequate mechanical surface pressure in order to stabilize or support certain body parts are known as compression garments. They are usually designed as stockings, sleeves, bandages, pants etc., to provide medical therapy including orthopaedic support, venous disease and scar (i.e. burns) management, also to improve or help in athletes performance as well as to provide aesthetic effect only, by body-shaping [1, 2]. Factors affecting the resulting pressure (at the fabric and tissue interface) due to compression garments include: fabric elastic modulus, stretch/reduction factor characteristics, body curvature and compliance. In order for the compression garment to provide the body part tissue with the right pressure, one needs to take into account both fabric properties and body characteristics as well as its shape and size and to define their relation with the generated pressure [3]. Studies dealing with the design of compression garments mostly focus on the mathematical (experimental) modelling of the pressure based on Laplace's law where generally both radius and internal pressure affect the container wall tension. The first mathematical model developed from the Laplace's law also predicts a multi-layered compression garment pressure by multiplying the computed equation with the number of fabric layers as the total tension of the compression fabric is equal to the sum of the individual yarn tensions [4, 5].

*Kowalski K. et al* were modelling the unit pressure for pressure garments on body circumferences with variable curvature radii, as the garment can't provide constant unit pressure along the individual body parts circumferences. Thus it was important to take into account the curvature radius of the body part where the pressotherapy was conducted [6]. The mathematical model of *Sikka M. P. et al*, where the sub-bandage pressure was predicted for multi-layered bandages, considered a conical configuration of a limb that is normally wider at the calf but narrower at the ankle, by using the membrane shell theory. The authors showed that the experimental pressure values were not statistically different from the model values and also the thickness and limb geometry effects on the generated pressure were significant [5].

The motivation for this study is rather different from the forth mentioned usual usage of the compression garments, as noted mostly in medical or sports application. Thus, the study simply uses an everyday sock to compute the pressure generated between the sock hem and the limb, Figure 1.



Figure 1. Lower leg deformed by the tight sock.

The hem of the sock is its compressive part as it provides for the sock to stay in an almost fixed position. Unfortunately sometimes this part can be the cause of a certain limb discomfort as its applied compression is too high. In order to avoid such problems a computational model that gives the interface pressure between the sock and the limb tissue will be of paramount importance in the design of socks.

## BASIC THEORY OF ELASTIC THICK WALLED TUBES

### Starting Equations

The theory of thick walled tubes is a fairly standard part of advanced strength of materials, see for example [7]. Due to rotational symmetry both in geometry (domain limited by two concentric circles) and loading (uniformly distributed internal and/or external pressure), polar coordinates are applied and all variables of interest (components of stress and strain, displacements) depend on radial

coordinate  $r$  alone. The static equation follows from the equilibrium condition on a differential element of the tube, see Figure 2.

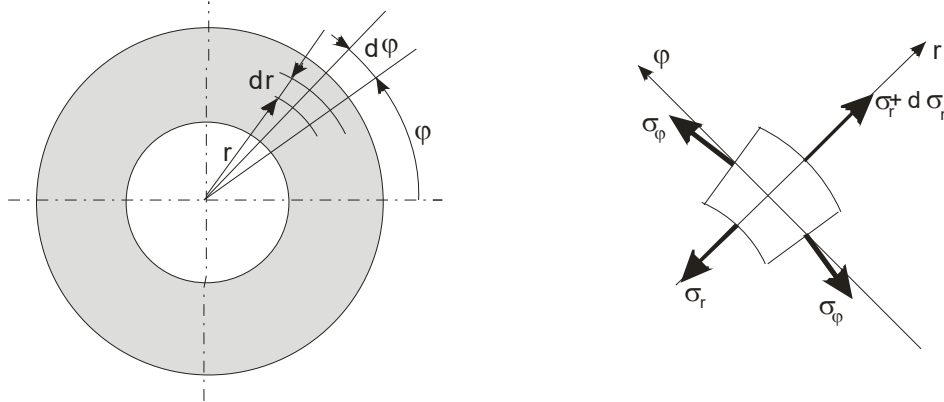

Figure 2. Thick walled tube in polar coordinates and stress components on a differential element

Equation of equilibrium in  $r$  direction reads

$$-\sigma_r \cdot rd\varphi + (\sigma_r + d\sigma_r)(r + dr)d\varphi - \sigma_\varphi \cdot dr \sin \frac{d\varphi}{2} \cdot 2 = 0 \quad (1)$$

Taking into account that  $d\varphi$  is very small, after rearranging and neglecting the small quantity of higher order this equation takes the form

$$(\sigma_r - \sigma_\varphi)dr + rd\sigma_r = 0 \quad (2)$$

Geometric analysis of the deformed state shows that the radial displacement  $u=u(r)$  is related to the radial and hoop components of strain by the equations

$$\varepsilon_r = \frac{du}{dr} \quad , \quad \varepsilon_\varphi = \frac{u}{r} \quad (3)$$

Finally, the components of stress and strain are related, for the considered case of linear elastic deformation, by the Hooke's law for plane stress ( $E$ =Young's modulus,  $\nu$ =Poisson's ratio)

$$\varepsilon_r = \frac{1}{E}(\sigma_r - \nu\sigma_\varphi) \quad , \quad \varepsilon_\varphi = \frac{1}{E}(\sigma_\varphi - \nu\sigma_r) \quad (4)$$

## Stress Distribution

Equations (2), (3) and (4) represent algebraic-differential system for five unknowns: radial and hoop components of stress and strain and radial displacement  $u$ . Mathematical processing of these equations delivers the solution in stresses which can be expressed in the form

$$\sigma_r = C_1 + \frac{C_2}{r^2} \quad , \quad \sigma_\varphi = C_1 - \frac{C_2}{r^2} \quad (5)$$

In the expressions (5)  $C_1$  and  $C_2$  are integration constants which follow from the boundary conditions: radial component of stress on internal and external boundaries keeps balance, i. e. corresponds to the given pressure as mechanical loading on these boundaries.

Here we illustrate the above on a typical example: consider the tube of simple geometry in which internal and external radii are  $R_1=R$ ,  $R_2=2R$ , loaded by internal pressure  $p$  (e. g. case of gun barrel). Using first of expressions (5) on each boundary, the conditions become

$$-p = C_1 + \frac{C_2}{R^2} \quad , \quad 0 = C_1 + \frac{C_2}{4R^2} \quad (6)$$

The solution of these equations is obtained in the form

$$C_1 = \frac{1}{3}p \quad , \quad C_2 = -\frac{4}{3}pR^2 \quad (7)$$

Expressions for stress components now finally become

$$\sigma_r = \frac{p}{3} \left( 1 - 4 \frac{R^2}{r^2} \right) \quad , \quad \sigma_\varphi = \frac{p}{3} \left( 1 + 4 \frac{R^2}{r^2} \right) \quad (8)$$

These expressions represent the distribution of radial and hoop stress components in terms of radial coordinate  $r$ . The distribution is illustrated in Figure 3. Hoop stress is tensile while radial stress is compressive. Maximum stress is hoop stress on the internal boundary when  $r=R$ ,  $\sigma_{\max}=5/3 p$ .

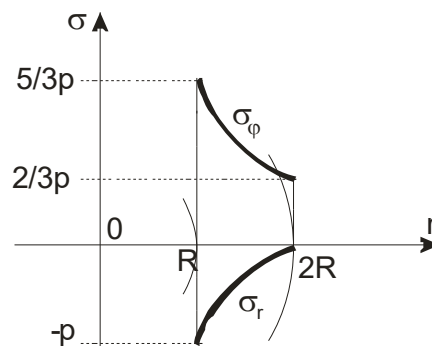

Figure 3. Distribution of stress components in the example of tube under internal pressure

### Elastic interaction of cylinder with rigid core and tightly fit thin tube

Let us try to apply the knowledge of the thick walled tube theory to the case where a limb (leg, arm) is exposed to the pressure resulting from a tightly fit elastic ring or thin tube – cylindrical membrane. Our primary interest is related to socks, but the model can also cover other cases of tight clothing or wearable items, including compressive equipment for athletes or compressive bandages in medical applications.

For the sake of simplicity let the cross section of the limb be modelled by the composite cylinder consisting of the rigid central core (the bone) and the homogeneous elastic soft tissue. In reality the soft tissue is composed of muscles, tendons, fat, skin, etc. This leaves the space for future refinements if a more detailed analysis is required. As for the tightly fit thin tube (the sock), it is also simplified as linearly elastic.

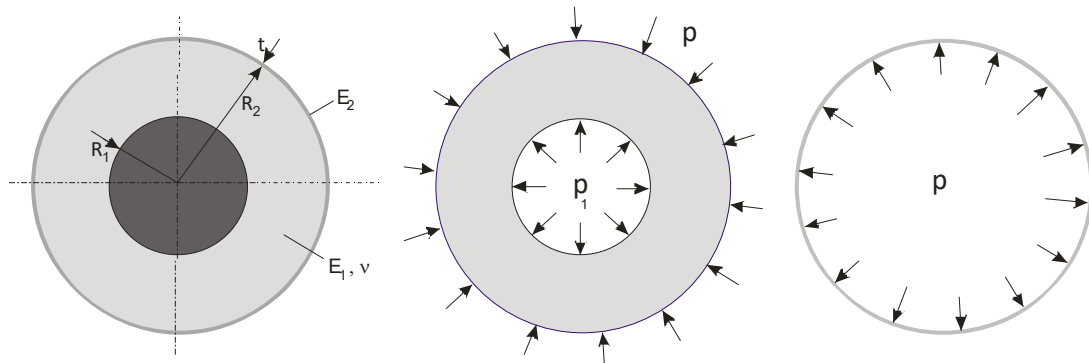

Figure 4. Assembly of cylinder with core and thin tube, pressure loads on soft tissue (center) and thin tube (right)

Consider the case of geometry and material properties shown in Figure 4 left.  $R_2$  is the undeformed initial radius of the cylinder and  $t$  is the thickness of the tight thin tube. The tightness is defined by the initial radial overlap of the cylinder and the tube: in the undeformed state the radius of the thin tube is smaller than  $R_2$  by the amount of radial overlap  $\Delta R$ .

Once the cylinder and the tube are assembled (as we put the sock on), elastic deformation takes place. The cylinder and the tube then act mutually on each other by the pressure  $p$ . There is also internal pressure on the soft tissue  $p_1$ , which comes from the resistance of the rigid core (bone, dark region in Figure 4.) to allow for any reduction in internal radius  $R_1$  that would normally take place in the absence of the core.

Boundary conditions for stresses on internal and external boundaries are now, with  $p$  and  $p_1$  yet to be determined,

$$\sigma_r(R_2) = -p \quad , \quad \sigma_r(R_1) = -p_1 \quad (9)$$

Further boundary conditions are expressed in terms of displacements: radial displacement on internal boundary is zero, while radial inward displacement on external boundary of the tissue and the increase of radius of the thin tube together make up for the initial overlap  $\Delta R$ :

$$u(R_1) = 0 \quad , \quad -u(R_2) + \Delta R_{tube} = \Delta R \quad (10)$$

Based on equations (3), (4) and (5) radial displacement  $u$  is expressed in the form

$$u = \frac{r}{E_1} \left[ C_1(1 - \nu) - \frac{C_2(1+\nu)}{r^2} \right] \quad (11)$$

Condition (10.1) now gives the equation for constants  $C_1$  and  $C_2$ :

$$C_2 = C_1 R_1^2 \frac{1-\nu}{1+\nu} \quad (12)$$

The second equation for  $C_1$  and  $C_2$  follows, using (5), from condition (9.1):

$$C_1 + \frac{C_2}{R_2^2} = -p \quad (13)$$

Solution of the system (12), (13) gives the expressions for the constants  $C_1$  and  $C_2$  in the form

$$C_1 = \frac{-p}{1 + \left(\frac{R_1}{R_2}\right)^2 \frac{1-\nu}{1+\nu}} \quad , \quad C_2 = \frac{-p R_1^2}{\frac{1+\nu}{1-\nu} + \left(\frac{R_1}{R_2}\right)^2} \quad (14)$$

From simple consideration of the thin tube its radial displacement has the form  $\Delta R_{tube} = pR^2/Et$  and so the condition (10.2) can be rewritten as

$$\frac{p R_2^2}{E_2 t} - \frac{R_2}{E_1} \left[ C_1(1 - \nu) - \frac{C_2(1+\nu)}{R_2^2} \right] = \Delta R \quad (15)$$

Now finally introduce (14) into (15) and solve for the unknown pressure  $p$  to obtain

$$p = \frac{\Delta R}{\frac{R_2^2}{E_2 t} + \frac{R_2}{E_1} \left[ \frac{1-\nu}{1 + \left(\frac{R_1}{R_2}\right)^2 \frac{1-\nu}{1+\nu}} - \frac{1+\nu}{\left(\frac{R_2}{R_1}\right)^2 \frac{1+\nu}{1-\nu} + 1} \right]} \quad (16)$$

Large bracket in the denominator of (16) is numerically tested and proven positive for a range of possible values of Poisson's ratio  $\nu$  and geometric ratio  $R_2/R_1$ .

## Example

In the example let us consider the case in which actual values of material and geometric data are not given, but rather their ratios with reference to the selected parameter: if for example modulus  $E_2$  and radius  $R_2$  are selected as reference and all the other data are expressed as reference data multiplied by the appropriate factor, then final results (stresses, displacements) shall also be expressed with reference to them. Let us adopt the following relations between the parameters:  $E_1=0.05E_2$ ,  $R_1=0.5R_2$ ,  $t=0.02R_2$ ,  $\Delta R=0.2R_2$ . As for the Poisson's ratio, consider three cases in the possible range: a)  $\nu=0$ , b)  $\nu=0.3$ , c)  $\nu=0.5$ . Calculation based on expression (16) gives the following values of the pressure: a)  $p=0.0032258 E_2$ ; b)  $p=0.0033753 E_2$ ; c)  $p=0.0035135 E_2$ . Note that the cylinder behaves stiffer as the Poisson's ratio is increasing. Deformations are calculated next: expression for  $\Delta R_{\text{tube}}$  gives the following values: a)  $\Delta R_{\text{tube}}=0.16129 R_2$ , b)  $\Delta R_{\text{tube}}=0.1688 R_2$ , c)  $\Delta R_{\text{tube}}=0.17567 R_2$ , which means that the deformation of the tube covers roughly 80 to 88 per cent of initial radial overlap. Finally, constants  $C_1$  and  $C_2$  are computed to give the stress components on internal and external boundary of the soft tissue. The results are shown in Figure 5 as distribution of stresses in the tissue.

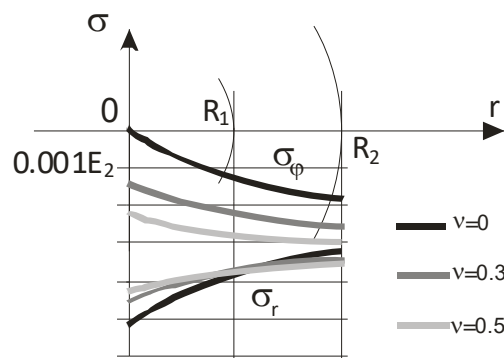

Figure 5. Example: distribution of the stress components for three values of the Poisson's ratio

## CONCLUSIONS

The theory of thick walled tubes provides possibilities for computational approach to limb in interaction with compression garment. Computed values of pressure and stresses in the tissue can guide to the conclusions regarding comfort and danger of overload. The proposed simple model can be improved and refined in the future work in several aspects: the tissue can be separated in several layers with different properties (for example muscle, fat, skin...) and furthermore it can be modelled as viscoelastic material. On the other hand, the compression garment in reality behaves nonlinearly, which can be incorporated in appropriate elastic model, for example bilinear, parabolic and the like. The computed example has demonstrated how different values of the Poisson's ratio can result in variation of stress distribution with otherwise equal parameters. Insight in the case of asymmetric



geometry could require more sophisticated theory, or application of discretised computation e.g. by the finite element method.

## REFERENCES

- [1] MacRae B A, Cotter J D, Laing R M. Compression Garments and Exercise, Garment Considerations, Physiology and Performance. *Sports Medicine*. 2011;41(10):1-29.
- [2] Xiong Y, Tao X. Compression Garments for Medical Therapy and Sports. *Polymers*. 2018; 10(6):663.
- [3] Chattopadhyay R, Bera M. Prediction of Pressure due to Elastic Fabric Tube Following Energy Principle. *Journal of Textile Engineering and Fashion Technology*. 2017;2(5):00075.
- [4] Thomas S. The use of the Laplace equation in the calculation of sub-bandage pressure. *World Wide Wounds*. 2002;3(1):21-23. Available from:  
<http://www.worldwidewounds.com/2003/june/Thomas/Laplace-Bandages.html>
- [5] Sikka MP, Ghosh S, Mukhopadhyay A. Mathematical modeling to predict the sub-bandage pressure on a conical limb for multi-layer bandaging. *Medical Engineering & Physics*. 2016;38(9):917-921.
- [6] Kowalski K, Mielicka E, Kowalski T M. Modelling and Designing Compression Garments with Unit Pressure Assumed for Body Circumferences of a Variable Curvature Radius. *Fibres & Textiles in Eastern Europe* 2012;206A(95):98-102.
- [7] Alfirević, I.: Viša nauka o čvrstoći I, Sveučilišna naklada Liber, Zagreb 1975. (Advanced strength of materials, in Croatian)

# THE COMPRESSIBILITY OF FINE WOMEN'S HOSIERY WITH ELASTANE

Željka PAVLOVIĆ<sup>1\*</sup>, Tea JOVANOVIĆ<sup>1</sup>, Lozo MILOŠ<sup>2</sup>, Zlatko VRLJIČAK<sup>1</sup>

<sup>1</sup>Faculty of Textile Technology, Prilaz Baruna Filipovića 28a, 10000 Zagreb, Croatia, \*email: zeljka.pavlovic@ttf.hr

<sup>2</sup>Hosiery Factory 8. mart, Subotica, Serbia

---

## ABSTRACT

*The raw materials, fineness and yarn structures for the production of simple fine women's hosiery and hosiery with increased compression are listed. Tubular knitted samples were made of a uniform structure used in making of fine women's hosiery. The samples were made on a 100 mm (4 inches) diameter of a cylindrical knitting machine with 400 needles and the gauge of E32. Tubular knitted samples were made in three weft structures: plain, partially plated 1+1 and fully plated. In each structure, three subgroups of samples with three different loop sinking depths of 550, 700 and 850 units were knitted. In this way, nine basic samples were obtained that presented the basic structures of fine elastic women's hosiery with increased compression. In the manufacturing of the samples, the basic yarn is Polyamide with the fineness of 60 dtex f 60 and the yarn plating is the elastane yarn with the fineness of 22/17 dtex f7. The parameters of the knitting structure were measured with special emphasis on the length of the yarn in one knitted row, which ranged from 570 to 1268 mm. The tensile properties of the samples were measured in the wale and course direction. The compressibility of such tubular elastic knitted fabrics was measured after their tightening on a stiff cylinder which imitated the diameter/circumference of a particular part of the woman's leg. The diameter/circumference of cylinders were 75/240, 110/350, 125/395, 160/510, 205/630 and 250/785 mm. The measured compression was up to 2,4 kPa (18 mmHg). The simpler constructions of fine women's hosiery are attaining compression on the cylinder (leg) up to 1,1 kPa (8 mmHg), increased compression hosiery up to 2,3 kPa (17 mmHg) and hosiery with a maximum compressibility up to 2,4 kPa (18 mmHg).*

## KEYWORDS

*Fine women's hosiery, polyamide (PA), elastane, stretching, compression*

---

## INTRODUCTION

Fine woman's hosiery is made on cylindrical knitting machines with 90 to 125 mm cylinder diameter (from 3 ½ to 5 e"), with 330 to 480 needles. Hosiery designed for adult women are often made on a machine with 100 mm diameter (4e") with 400 needles and the gauge of E32 [1,2]. When making simpler and cheaper hosiery, polyamide (PA), less polyester (PES) multifilament yarns are commonly used. Due to the comfortable fit of the hosiery with the leg and the wearing comfort, besides the PA filament yarn, various elastic threads are used which increase the price of hosiery. When knitting hosiery, elastane can be knitted in various ways. In a fully plated structure, next to the basic yarn, elastane yarn is knitted in every row. In partial plating, the elastane yarn is knitted in every other or every third row, or in any other arrangement. It can also be knitted only on a special part of

the hosiery. The proportion of the elastane yarn significantly determines the stretch properties of hosiery, i.e. its compression, and thus the wearing comfort of the hosiery [3,4].

### COMPRESSIBILITY OF FINE WOMEN'S HOSIERY

In order for a pantyhose to be put on the leg in the ankle area where circumference is about 20 cm, then to the subcutaneous muscle, calf, having the circumference of 34 cm, or on the leg with 57 cm circumference, it is understandable that the knitted structure should be different in all three mentioned parts. As the leg girth increases almost continuously from the ankle to the groin, the structure of the hosiery has to be changed. When making simpler hosiery this change is achieved with loop sinking depth. At the minimum depth, the needle pulls the least amount of yarn for forming the loop, thus knitting the narrowest part of the hosiery. At the maximum depth, the most amount of yarn is pulled, making the widest part of the hosiery. At higher stretching of the hosiery, of about 20%, hosiery comfortably fits on the body [5,6].

The yarn knitted in the hosiery is very free and stretchy so with just a little force, great deformation is achieved. While putting the hosiery on the leg, forces up to 50 N are used and the hosiery is stretched transversely. Then it stretches longitudinally, and so on until it is put on completely. When the tubular knitwear is pulled to a certain part of the leg, then the forces acting transversely and longitudinally in the hosiery occupy a balanced position and their resultant acts as a compression force on the leg. The amount of the force is an integral part of the rating associated with the fitting and comfort of wearing the hosiery. From a medical point of view, basically, the greatest pressure from the hosiery should be in the foot, slowly lowering towards the upper leg. When knitting sports and medical hosiery, greater attention is paid to the compression on a specific part of the leg. For all hosiery, the compression at a certain stretching is important. For classic fine woman's hosiery, the compressibility is usually up to 1 kPa or up to 7 mmHg. This compression is considered insignificant. Fine woman's compression hosiery has a compression from 1 up to 2 kPa or 7 to 15 mmHg. Medical hosiery has a compression of 2,4 to 6,5 kPa, even more, table 1 [7,8].

Table 1. Compressibility of medical hosiery [7,8]

Class	Degrees of compression	Compression, kPa
I	<i>light</i>	2,4 – 2,8
II	<i>moderate</i>	3,1 – 4,3
III	<i>firm</i>	4,5 – 6,1
IV	<i>extra firm</i>	6,5 and higher

*1 kPa = 7,5 mmHg; 1 mmHg = 0,133 kPa*

## MEASURING THE COMPRESSION OF FINE WOMEN'S HOSIERY

Hosiery compressibility on a rigid surface (or leg) is measured by various methods and measuring devices [9-12]. The most commonly known as a measuring device is a model with wooden legs intended for measuring the compression of short socks, knee socks and pantyhose, Figure 1. [9]. According to established medical practice, hosiery compression is expressed in mmHg or optional in kPa. Recently, more attention is paid to compression wear, so compression is measured on a cylinder of a certain diameter with a PicoPress device [10]. In this case, the hosiery or a garment is put on a cylinder of a certain diameter, through which the stretch of an object is recorded and its compressibility measured.

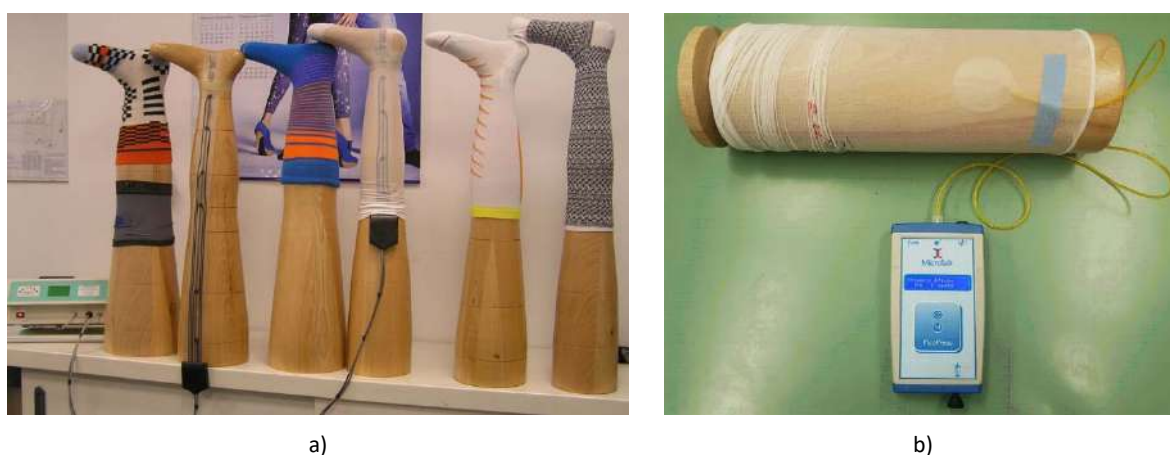

Figure 1. Measuring the compressibility of hosiery and elastic tubular knitwear; a) on wooden leg models [9] and b) with PicoPress device on a cylinder with certain diameter

## EXPERIMENTAL

The main aim of this research is to find out how much the fibre composition, knitted structure and loop sinking depth affect the compressibility of fine women's hosiery.

Most of the simple fine women's hosiery are knitted in a plain structure, and more complex design with higher compressibility are knitted in various plated structures, so the samples in this research are made in above mentioned plated structures [5,6]. For the samples, a 100 mm (4e") diameter of a cylindrical knitting machine was used, with 400 needles on four knitting systems. Its gauge was E32, cylinder working speed was from 250 to 700 rpm.

The machine is used daily in the knitting mill. With this kind of machines, it is recommended to knit fine women's hosiery with multifilament yarns fineness from 13 to 72 dtex. When knitting fine women's hosiery, one yarn and different loop sinking depths are often used [13,14]. In this research, the samples were made with three most commonly loop sinking depths; 550, 700 and 850 units. For the knitting of basic structure, a PA filament yarn with the fineness of 60 dtex f 60 was used, which had

a breaking force of 246 cN and elongation at break of 26%. For plating a wrapped elastane yarn with the fineness of 22/17 dtex f 7 was used, which had a breaking force of 103 cN and elongation at break of 33%, Figure 2.

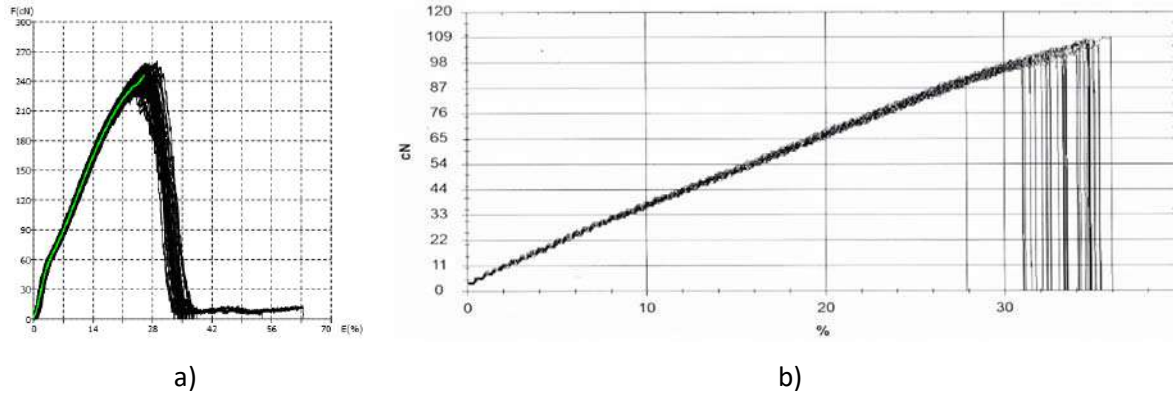

Figure 2. Yarn tensile properties: a) Polyamide multifilament yarn fineness 60 dtex f 60 and b) wrapped elastane yarn fineness 22/17 dtex f 7

## RESULTS OF MEASURING THE KNITTED STRUCTURE PARAMETERS

Since the aim of this paper is the compression of knitwear, the loop length has been measured as the most important parameter of the knitted structure, since it is substantially affecting the stretching, and thus the compression of the knitted fabric. Three basic samples were made. The first sample was made in the plain structure, the second one is partially plated structure where the polyamide yarn was in every row and elastane yarn was in every other row. The third sample was made in a fully plated structure where the two yarns were knitted in every row: one polyamide yarn and one elastane yarn. Because of such structure, it was necessary to split the yarns separately from individual rows and then measure their length. The above-mentioned analysis was carried out on all the knitted samples with different fineness and loop sinking depths.

The results of measuring the length of the yarn knitted in a row was performed by ripping the yarn from the structure [15]. The tubular knitted samples were made on a machine with 400 needles, so there are 400 loops in each row. Samples were made in three different loop sinking depths: 550, 700 and 850 units. The threads are ripped in a way that a tubular sample was cut longitudinally between two wales of loops and each yarn is separated individually from the rows. Each ripped yarn was measured manually on a special device that measures its length. One end of the yarn is fixed to the upper clamp, and the other end is attached to a load of 0,7 cN/tex, and then the yarn length is measured. For the polyamide yarn with the fineness of 60 dtex the load was 4,2 cN, and for the elastane yarn, it was 1,5 cN.

The knitted samples were made on a cylindrical knitting machine with the 100 mm (4e") diameter, and the circumference of the needle bed is 319 mm. The machine has four knitting systems that can knit with many different yarns. When knitting the first sample, every knitting system was fed with PA multifilament yarn with the fineness of 60 dtex f 60. Odd systems were fed by the yarns with the S twist and even systems with the yarns with Z twist. At the loop sinking depth with 550 units, the width of the samples was 116 mm x 2, where the shrinkage in the course direction was 27 %, table 2. At the loop sinking depth with 700 units, the width of the samples was larger, 119 mm x 2, so the shrinkage was smaller, it was 25 %. With the biggest loop sinking depth with 850 units, the width was 130 mm x 2, and the shrinkage was 18 %.

The mass of the square meter of the samples was from 77 to 92 g/m<sup>2</sup>. The samples made in partially plated structure 1+1 have a polyamide yarn with the fineness of 60 dtex f 60 as their basic yarn, and in every other row, the elastane yarn with the fineness of 22/17 dtex f 7 was knitted. Due to the elastane yarn, shrinkage of the samples was increased, it was in the range from 29 to 33 %, reducing the width in the range from 107 mm x 2 to 113 mm x 2, and increasing the grammage in the range from 118 to 143 g/m<sup>2</sup>. In the samples made in the fully plated structure, there were two yarns knitted in every row, one polyamide and one elastane yarn. The knitted elastane yarn in every row increases the shrinkage even more, it is now in the range from 31 to 38 %, thereby reducing the width of the tubular samples, which is in the range from 99 mm x 2 to 110 mm x 2. With this kind of shrinkage and knitting the two yarns in every row, a relatively large mass of the square meter of 174 to 189 g/m<sup>2</sup> is obtained.

Table 2. Structural parameters of the knitted samples

T <sub>t</sub> dtex	structure	h <sub>k</sub>	m, g/m <sup>2</sup>	S <sub>p</sub> , mm	s, %	m <sub>z</sub> , g/cm <sup>3</sup>	C	L <sub>PA</sub> , mm	L <sub>PA+</sub> , mm	L <sub>LY</sub> , mm
60	plain	550	92	116	27	0,213	0,50	988±3		
		700	83	119	25	0,181	0,60	1128±5		
		850	77	130	18	0,175	0,61	1268±7		
60 + 22/17	plated 1+1	550	143	107	33	0,304	0,45	944±7	894±13	570±8
		700	125	110	31	0,242	0,58	1025±9	987±13	612±9
		850	118	113	29	0,208	0,72	1167±6	1129±11	674±9
60 + 22/17	plated	550	179	99	38	0,354	0,48		896±13	623±13
		700	178	105	34	0,303	0,50		1015±11	692±11
		850	174	110	31	0,274	0,51		1125±13	754±14

Where: T<sub>t</sub> – yarn fineness, dtex, h<sub>k</sub> – loop sinking depth, dimensionless, m – mass per square meter, g/m<sup>2</sup>, S<sub>p</sub> – width of the knitwear, mm, s – shrinkage after taking the knitwear off the machine, %, m<sub>z</sub> – volume mass of the knitwear, g/cm<sup>3</sup>, C – coefficient of fabric tightness, L<sub>PA</sub> – length of the basic, PA yarn in one row, mm, L<sub>PA+</sub> – length of the basic, PA yarn when plated with elastane yarn in one row, mm, L<sub>LY</sub> – length of the elastane yarn in one row, mm.

For the analysis of the stretching properties of hosiery, the length of the yarn in one row is very significant. When the plain hosiery with loop sinking depth of 550 unit is being made, then a  $988 \pm 3$  mm PA multifilament yarn is being knitted into one row, and with the 850 unit,  $1268 \pm 7$  mm yarn is knitted, or 28% more than the smaller loop sinking depth. At partial plating 1+1, PA yarn has the length of  $994 \pm 7$  mm to  $1167 \pm 6$  mm, i.e. less than when it is being knitted alone in all rows in plain structure. However, in the rows where the PA yarn is knitted with elastane yarn, its length is even smaller and it is in the range from  $894 \pm 13$  mm to  $1129 \pm 11$  mm, and the elastane yarn has the length from  $570 \pm 8$  mm to  $674 \pm 9$  mm. In fully plated structure the length of the PA yarn is  $896 \pm 13$  mm to  $1125 \pm 13$  mm, and the length of the elastane yarn is  $623 \pm 13$  mm to  $754 \pm 14$  mm, more than in partial plated structure. Different lengths of knitted yarns in a row depend to a large extent on the yarn structure and regulation on the machine while knitting with this yarns and structures.

### RESULTS OF THE TENSILE PROPERTIES OF KNITWEAR

Elongation of knitted fabrics was measured in the course and wale directions. For these measurement's samples were 50 mm wide and 200 mm long. The distance between the grippers of the tensile strength tester was 75 mm [6, 14]. In table 3, the average values of the elongation of the knitwear up to breakage in course direction ( $\epsilon_{tp}$ ), which is in the range from 270 to 445 % are given. Also, the approximate values of the individual's parts of the elongation up to breakages like elasticity, permanent deformation and the area between elastic and permanent deformation are also given.

Table 3. Measurement results of fabric elongation in course direction (transverse) with approximate parts

$T_t$ dtex	structure	$h_k$	$\epsilon_{ep}$ , %	$\Delta\epsilon_{ep}$ , %	$\epsilon_{pp}$ , %	$\Delta\epsilon_{pp}$ , %	$\Delta\epsilon_{pp} - \Delta\epsilon_{ep}$ , %	$\epsilon_{tp}$ , %	$\Delta\epsilon_{tp} - \Delta\epsilon_{pp}$ , %
60	plain	550	120	44	160	59	15	270	41
		700	180	53	240	70	18	342	30
		850	180	50	250	69	19	360	31
60 + 22/17	plated 1+1	550	120	39	180	58	19	310	42
		700	130	36	200	56	20	357	44
		850	160	42	240	64	22	377	36
60 + 22/17	plated	550	120	38	220	69	31	320	31
		700	130	33	230	58	25	399	42
		850	150	34	210	47	13	445	53

Where:  $\epsilon_e$  – stretching or elongation of the fabric, up to the end of elastic area, %;  $\epsilon_p$  – stretching or elongation of the fabric, up to the beginning of the plastic area, %;  $\epsilon_t$  – stretching or elongation of the fabric up to the moment of tearing, %,  $\Delta\epsilon_e$  – share of the elastic area in relation to the total elongation, %;  $\Delta\epsilon_p$  – share up to the beginning of the plastic area in relation to the total elongation, %;  $\Delta\epsilon_p - \Delta\epsilon_e$  – share between plastic and elastic area, %;  $\Delta\epsilon_t - \Delta\epsilon_p$  – share between point of breakage and the beginning of the plastic area, %; course direction marked with index  $p$  – transverse, and in Table 4 longitudinal direction is marked with index  $u$

From the tensile strength diagram, the elasticity area ( $\epsilon_{ep}$ ) for the analysed samples was estimated, and it ranged from 120 to 180 %, or 33 to 50 % from elongation at break. Also, the starting point of the plastic area was estimated, and it ranged from 160 to 250 %, and it occupies from 47 to 70 % of the total elongation of the knitwear. It is important to note that the share between the end of the elastic area and the beginning of the plastic area is from 13 to 25 %, while the plastic area is from 30 to 53 %. Elasticity, plastic deformation and the elongation at break of the knitwear, depend on the knitted structure and the loop sinking depth.

In table 4, the average values of the elongation of the knitwear up to breakage in wale direction ( $\epsilon_{tu}$ ), which is in the range from 248 to 522 %. The average share of elasticity ( $\epsilon_{eu}$ ) is ranged from 34 to 60 % from elongation at break and is reduced by larger amounts of knitted elastane yarn. The share of plastic deformation in the total elongation of the knitwear is ranged from 27 to 55 % and was lower than in course direction, where it ranged from 30 to 53 %.

The three analysed areas of the knitwear elasticity: elastic area, plastic area and the area between the end of elastic and the beginning of permanent deformation and their amounts with stretching significantly affect the compressibility of the hosiery on a part of the leg, and hence the wearing comfort of the hosiery.

Table 4. Measurement results of fabric elongation in wale direction (longitudinal) with approximate parts

$T_t$ dtex	structure	$h_k$	$\epsilon_{eu}$ , %	$\Delta\epsilon_{eu}$ , %	$\epsilon_{pu}$ , %	$\Delta\epsilon_{pu}$ , %	$\Delta\epsilon_{pu} - \Delta\epsilon_{eu}$ %	$\epsilon_{tu}$ , %	$\Delta\epsilon_{tu} - \Delta\epsilon_{pu}$ %
60	plain	550	160	58	190	69	11	277	31
		700	150	58	180	69	12	260	31
		850	150	60	180	73	12	248	27
60 + 22/17	plated 1+1	550	150	35	210	49	14	432	51
		700	160	45	210	55	10	385	45
60 + 22/17	plated	550	170	44	230	60	16	385	40
		550	150	34	200	45	11	442	55
		700	200	43	250	54	11	465	46
		850	180	34	240	46	12	522	54

## RESULTS OF HOSIERY COMPRESSIBILITY MEASUREMENTS

Compressibility measurements of tubular knitted samples was performed with the PicoPress device [10] on six rigid cylinders with diameters 75, 110, 125, 160, 205 and 250 mm having an approximate circumference of 240, 350, 395, 510, 630 and 785 mm, and in the diagrams, they were labelled as diameter/circumference: 75/240, 110/350, 125/395, 160/510, 205/630 and 250/785 mm. With the circumference of the cylinder, the circumference of the specific part of the leg was imitated.



First group of samples were made with PA multifilament yarn with the fineness of 60 dtex f 60 with three different loop sinking depths: 550, 700 and 850 units, with the length of the yarn in one knitted row ranged from  $988 \pm 3$  mm to  $1268 \pm 7$  mm, table 2. Compressibility of such knitwear is from 1 to 8 mmHg (0,13 to 1,1 kPa), Figure 3a. Second group of samples was made in partial plated structure 1+1, where every row is knitted with PA multifilament yarn with the fineness of 60 dtex f 60, and every other row was plated with wrapped elastane yarn with the fineness of 22/17 dtex f 7. This samples achieve much higher compression within the range from 1 to 17 mmHg (0,13 to 2,3 kPa), whereby compression is increased more with increasing tensile strength, Figure 3b. Third group of samples were made in fully plated structure where there are two yarns in each row, one PA multifilament yarn with the fineness of 22/17 dtex f 7 and the other wrapped elastane yarn with the fineness of 22/17 dtex f 7. In this way, the considerably fuller knitted structure is obtained with increased shrinkage, and thus significantly larger mass per unit area (table 2) and greater compression is achieved ranging from 5 to 18 mmHg (0,7 to 2,4 kPa), Figure 4a.

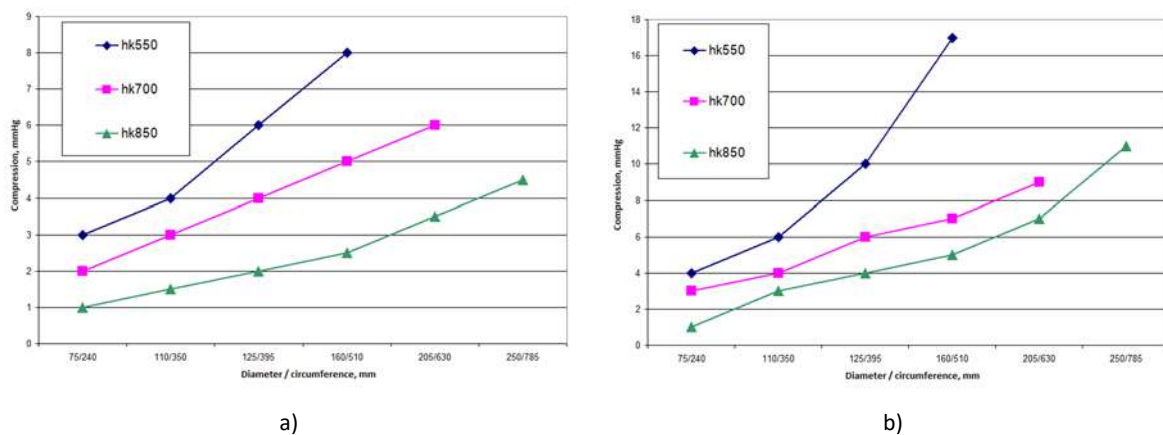

Figure 3. Results of elasticity measurements of tubular knitted samples in course direction – transverse, and their compressibility: a) plain samples, b) partial plated samples 1+1

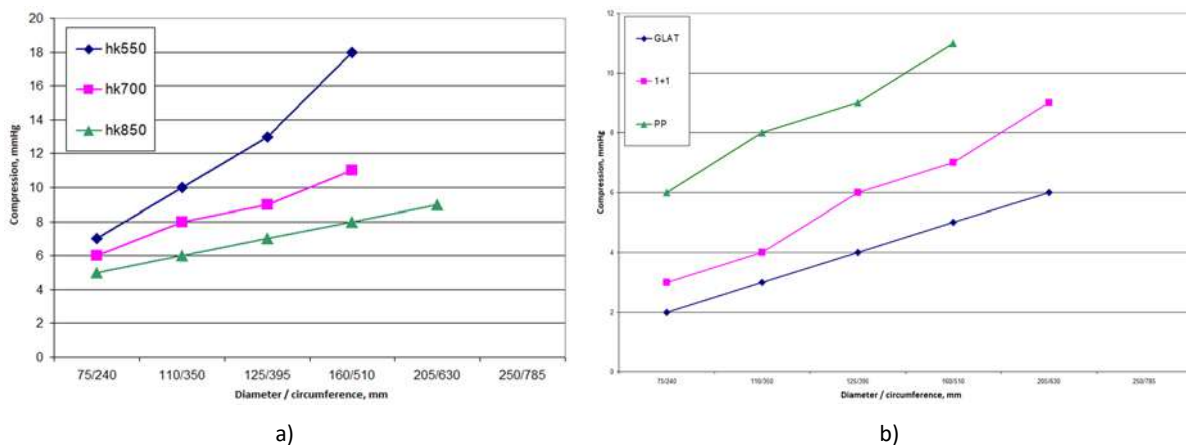

Figure 4. Results of elasticity measurements of tubular knitted samples in course direction – transverse, and their compressibility: a) fully plated samples, b) plain, partially and fully plated samples with loop sinking depth of 700 units

When knitting the samples in plain structure and with the lowest loop sinking depth of 550 units, then the length of the PA yarn in one row is  $988 \pm 3$  mm. If knitwear like that is put on a cylinder with 75 mm in diameter or 240 mm circumference, then the compression of the knitwear is 3 mmHg (0,4 kPa). When the cylinder has 110 mm in diameter or 350 mm circumference, corresponding to the circumference of the leg below the knee, compression of the knitwear is 4 mmHg (0,5 kPa). That kind of sample can be put on the cylinder with 160 mm in diameter or 510 mm circumference, which is circumference corresponding with the leg above the knee, then the compression is 8 mmHg (1,1 kPa). Samples knitted with the loop sinking depth of 700 units have  $1128 \pm 5$  mm of yarn in one row, and they can be stretched more and be fitted on cylinder up to 205 mm in diameter or 630 mm circumference, then the compression is 2 to 6 mmHg (0,3 to 0,8 kPa). Samples knitted with the loop sinking depth of 850 units have  $1268 \pm 7$  mm of yarn in one row, which produces a compression from 1 to 4,5 mmHg (0,13 to 0,6 kPa) on a cylinder with 75 to 250 mm in diameter or 240 to 785 mm circumference. The diagram shows that the biggest compression level of 8 mmHg (1,1 kPa) is achieved with the sample made with the smallest loop sinking depth of 550 units and the cylinder of 510 mm circumference. Smaller compression of 5 mmHg (0,7 kPa) is achieved with the samples knitted with the loop sinking depth of 700 units, and the smallest compression is 2,5 mmHg (0,3 kPa) is achieved with the samples knitted with the biggest loop sinking depth of 850 units.

Samples made in the partially plated structure have the elastane yarn with the fineness of 22/17 dtex f 7 knitted in every other row, which significantly influences the structure and tensile properties of knitwear. First, it should be noted that by adding the additional yarn, the base yarn is behaving differently, table 2. Additional elastane yarn increases shrinkage in the course direction, and thus the elongation resistance of the knitwear. Putting it on a cylinder with 75 mm in diameter, the compression was 4 mmHg (0,5 kPa), Figure 3b. This type of knitted structure can be measured on a cylinder up to 160 mm in diameter or 510 mm circumference, whereby the compression is 17 mmHg (2,3 kPa). When knitting two yarns in every row, where one is PA multifilament yarn with the fineness of 60 dtex f 60 and the other is wrapped elastane yarn with the fineness of 22/17 dtex f 7, the shrinkage is even greater and the compression is increased in the range from 7 to 18 mmHg (0,9 to 2,4 kPa) with the loop sinking depth of 550 units, Figure 4a.

When making a fine women's hosiery, ten to fifteen different loop sinking depths are being used. Each manufacturer has its own principle of using the loop sinking depth in each part of the hosiery. Because of this, hosiery of individual manufacturers is only suitable for some women, and often because different shaped legs, other women find them uncomfortable to wear. The loop sinking depth of 700 units is often used in making the fine women's hosiery. In order to show the influence of the loop sinking depth and structure on compression of the hosiery, the three mentioned structures made with loop sinking depth of 700 units will be analysed.

Based on the data obtained by the measurements, it is interesting to note that, for example, compression of the hosiery on the leg of 6 mmHg (0,8 kPa) can be achieved in the ankle area with a 240 mm circumference only when the knitwear is made in fully plated structure and the loop sinking depth is 700 units. The same compression of the hosiery on the leg is obtained with the partially plated structure 1+1 but with the larger stretching of the fabric, when the circumference is 395 mm and below the knee. When hosiery is being knitted in plain structure with the loop sinking depth of 700 units, then this kind of compression is achieved with even greater stretching of the fabric, when the circumference is 630 mm and located on the upper part of the leg. Consequently, the loop sinking depth and knitted structure directly affect the compression of the hosiery on the specific part of the leg. By using different loop sinking depths, structures, yarn fineness and yarn structures, certain amounts of compression are obtained. For this reason, manufacturers of fine women's hosiery are advised to optimally and rationally use these parameters in the designing of their product. Because of this, larger manufacturers of fine women's hosiery study the market to which they place their products, so that they can satisfy and retain existing customers and, if possible, get some new ones.

## CONCLUSIONS

Simple fine women's hosiery or pantyhose are the most commonly made with PA multifilament yarns in plain weft structure. The higher quality and more expensive hosiery are made with microfilament yarns. Hosiery with increased compressibility are knitted in partially plated structure, most often 1+1, i.e. all the rows are knitted with PA multifilament yarn and every other row is reinforced with elastane yarn. The greatest compression of the hosiery is obtained when one row is knitted with two yarns: one PA and one elastane yarn. The compressibility of hosiery is associated with stretching which depends on the length of the yarn knitted in one row and the elasticity of the yarn. Increasing the loop sinking depth, the length of the yarn in one row is increased as well, thereby reducing the compression on the constant circumference of the leg. Elongation at break of the knitted and analysed samples in course direction was from 270 to 445 %, and wale direction from 248 to 522 %. Compression of hosiery made in plain structure, i.e. only with PA yarns, is from 1 to 8 mmHg (0,13 to 1,1 kPa), compression of hosiery knitted in partially plated structure 1+1 is bigger and it is ranged from 1 to 17 mmHg (0,13 to 2,3 kPa), and the highest compression is obtained with a fully plated structure and it is ranged from 5 to 18 mmHg (0,7 to 2,4 kPa). According to the above, structure and fineness of the yarn and knitted structure significantly affect the compression of the hosiery. In the future more and more, personalized manufacturing of fine women's hosiery is to be expected, i.e. knitting the hosiery according to the measures of a certain leg and the desired compression of the person wearing the product.

### **Acknowledgement**

This work has been fully supported by Croatian Science Foundation under the project (IP-2016-06-5278).

### **REFERENCES**

- [1] Modig N: Hosiery Machines, Meisenbach, Bamberg, (1988)
- [2] Bašnec I. Proces izrade finih ženskih čarapa. *Tekstil* **43**(1994.) 5, pp.255-259
- [3] Lozo M. & Vrljičak Z.: Rastezna svojstva finih ženskih čarapa s gaćicama, In: Grilec T. editor. Proceedings of the MATRIB 2014, International conference on materials, tribology, recycling; 26 – 28 June; Vela Luka, Croatia. Zagreb: Croatian Society for Materials and Tribology; 2014. pp.278-288
- [4] Lozo M. & Vrljičak Z. Structure and Elongation of fine Ladies' Hosiery, In: Weber M.O. editor. Proceedings of the 48. Congress of the International Federation of Knitting Technologists (IFKT); 09 - 10 June; Moechengladbach, Germany. Wegberg, Germany: the International Federation of Knitting Technologists; 2016. pp. 1-10
- [5] Lozo M., Pavlović Ž. & Vrljičak Z. Parametri strukture pletiva finih ženskih čarapa s elastanskom niti, In: Ercegović Ražić S. editor. Book of Proceedings of the 11<sup>th</sup> Scientific – Professional Symposium Textile Science and Economy; 24 January; Zagreb, Croatia. Zagreb, Croatia: Faculty of Textile Technology; 2018. pp. 98-103
- [6] Lozo M., Pavlović Ž. & Vrljičak Z. Tensile properties and compressibility of fine women's hosiery, In: Melizkaja E. editor. Book of Proceedings of the 49th IFKT International Congress "Stepping into the future; 2 - 4 October; Lodz, Poland. Lodz, Poland: IW Textile Research Institute; 2018. pp. 1 – 13
- [7] RAL-GZ 387/1. Madizinische Kompressionsstruempfe, Dueren 2008.
- [8] BS 6612:1985; Graduated compression hosiery
- [9] <https://www.swisslastic.ch/en/products/pressure-measuring-devices/mst-mk-v-17>
- [10] <http://www.microlabitalia.it/case-history.php?azione=show&url=pico-press>
- [11] Ilska A. et al. Using a 3D Body Scanner in Designing Compression Products Supporting External Treatment. *Fibers & Textiles in Eastern Europe* **25**(2017) 5(125), pp. 107-112
- [12] Kowalski K. et al.: Influence of a Compression Garment on Average and Local Changes in Unit Pressure, *Fibers & Textiles in Eastern Europe* **25**(2017) 6(126), pp. 68-74
- [13] Lozo, M., Kraljević I. & Vrljičak, Z. Utjecaj finoće pređe i dubine kuliranja pri pletenju na rastezna svojstva finih ženskih čarapa, In: Ćorić D. & Žmak I. editors. Proceedings of the 16<sup>th</sup> International

- Conference MATRIB 2015, Materials, Wear, Recycling; 25 - 27 June; Vela Luka, Croatia. Zagreb: Croatian Society for Materials and Tribology; 2015. pp. 135-144
- [14] Pavlović Ž., Lozo M. & Vrljičak Z. Površinska deformacija čarapa prouzročena jednoosnim vlačnim opterećenjem, In: Glogar M.I. editor. Book of Proceedings of the 10<sup>th</sup> Scientific – Professional Symposium Textile Science and Economy; 24 January; Zagreb, Croatia. Zagreb, Croatia: Faculty of Textile Technology; 2017. pp. 121-126
- [15] Pavlović Ž., Lozo M. & Vrljičak Z. Problemi određivanja utroška niti u očici finih ženskih čarapa, *Tekstil* **65**(2016)1-2, pp. 35-46

# THE EFFECT OF THE FILLER AND LAYERS ON THE PROPERTIES OF ELECTROSPUN ANTIBIOTIC/FIBROIN SCAFFOLDS

Emilija ZDRAVEVA<sup>1\*</sup>, Budimir MIJOVIĆ<sup>1</sup>, Tamara HOLJEVAC GRGURIĆ<sup>2</sup>, Emi GOVORČIN BAJSIĆ<sup>3</sup>, Iva DEKARIS<sup>4</sup>, Mirna TOMINAC TRCIN<sup>5</sup>, Massimo UJČIĆ<sup>6</sup>, Patrycja KAZIUR<sup>7</sup>, Paulina MASLANKA<sup>7</sup>

<sup>1</sup>University of Zagreb Faculty of Textile Technology, Prilaz baruna Filipovića 28a, 10000 Zagreb, Croatia, \*email: emilija.zdraveva@ttf.hr

<sup>2</sup>University of Zagreb Faculty of Metallurgy, Aleja narodnih heroja 3, 44000 Sisak, Croatia

<sup>3</sup>University of Zagreb, Faculty of Chemical Engineering and Technology, Trg Marka Marulića 19, 10000 Zagreb, Croatia

<sup>4</sup>Specialty Eye Hospital Svjetlost and University of Rijeka, Department of Ophthalmology Medical Faculty, 51000 Rijeka, Croatia

<sup>5</sup>University Hospital Centre Sestre Milosrdnice, Tissue bank at University Department of Traumatology, 10000 Zagreb, Croatia

<sup>6</sup>Institute of Chemical Process Fundamentals, v. v. i., Rozvojová 135, Prague 6, 165 02, Czech Republic

<sup>7</sup>Erasmus+ students, Lodz University of Technology, Lodz, Poland

---

## ABSTRACT

*The study gives an insight into the research concerning development of electrospun scaffolds as part of the Croatian Science Foundation project. Electrospun composite scaffolds were prepared by electrospinning of neat polycaprolactone (PCL), as well as PCL blended with an antibiotic or silk fibroin separately and finally by electrospinning both PCL/fibroin and PCL/antibiotic within a layered configuration. The scaffolds were analysed in regard to their morphology, total porosity, surface wettability and tensile behaviour taking into account the type of filler and layered structure. The addition of the fillers resulted in the reduction of the water contact angle on the surface of the hydrophobic PCL. Thus, a hydrophilic surface is of paramount importance as it improves scaffolds cells adhesion. Also, the antibiotic and silk fibroin resulted in PCL fibres diameter reduction by 28% and increase by 224%, respectively. Fibers deformations or beads were present in case of the neat PCL and the PCL/fibroin fibres. The biggest pores area was in case of the PCL/fibroin of  $8.13 \pm 6.45 \mu\text{m}^2$ . The total porosity reduced gradually with the addition of the fillers, resulting in the lowest value in case of the layered scaffolds (from 94.2 to 68.5%). The tensile strength of the electrospun scaffolds improved with the addition of the antibiotic and in case of the layered structure, resulting in the maximum value of  $260.33 \pm 60.53 \text{ cN/mm}^2$ . These results suggest that the nature of the filler affects its miscibility with the polymer and electrospinning jet stretching and both porosity and tensile strength are affected by the scaffolds composition and layered structure. In this way by varying the composition and physical structure, scaffolds can be designed according to requirements in tissue therapy and repair.*

## KEYWORDS

*Electrospun scaffolds, PCL, antibiotic/fibroin, morphology, tensile properties*

---

## INTRODUCTION

Electrospun nanofibrous materials are designed to fulfil the requirements of scaffolds properties and function, very important in tissue engineering application. These requirements include the adequate physical structure that simulates the extracellular matrix, high porosity and

interconnectivity, biocompatibility, biodegradation that meets the rate of tissue regeneration and mechanical integrity to withstand tissue growth forces [1-3]. Electrospun scaffolds can be designed in regard to their structure and functional features to provide cells surface adhesion, tissue growth and repair. The architecture of the scaffolds can be altered to improve cells dipper penetration by versatile methods some of which include: laser ablation [4] rapid prototyping [5], direct writing electrospinning [6] etc.

These techniques provide topographical patterns that will result in cells guidance for their precise placement and growth. The chemistry of the scaffolds on the other hand is important for cells attraction and compatibility with the electrospun support. For this reason scaffolds are electrospun from biocompatible polymers combined with natural ones, while for further functionalization medicine or biological components are added as well. The function of these components is important in tissue therapy and their controlled release will depend on the material composition while it happens due to diffusion and polymer degradation or erosion [7].

This study considers several aspects in scaffolds development including cells attraction by natural polymers i.e. silk fibroin, further tissue repair by drug/antibiotic addition and finally patterned structure fabrication. Thus, electrospun scaffolds were prepared by electrospinning polycaprolactone blended with silk fibroin or with an antibiotic separately, as well as electrospinning both compositions within a layered configuration. This work is a small insight into the research of the Croatian Science Foundation project and focuses on the effect of the filler and the layers on some of the properties of electrospun scaffolds.

## **EXPERIMENTAL**

### **Materials and Methods**

Materials used in this study include: polycaprolactone (PCL) with Mn 80,000 purchased from Sigma Aldrich, Fibroin (Fb) in a form of silk powder purchased from Huzhou Xintiansi Bio-tech Co, Ltd, China and antibiotic cefuroxime kindly supplied by Specialty Eye Hospital Svjetlost, Croatia.

Electrospun composites were prepared by electrospinning of neat PCL, as well as PCL in a blend with an antibiotic (cefuroxime), or PCL in a blend with fibroin, in a mixture of glacial acetic acid and acetone. The solutions are prepared by constant stirring of a 14 % PCL polymer solution for 24 hours with a further addition of the antibiotic or the fibroin the concentration of 50 wt% or 6 wt%, respectively. Blend solutions were electrospun on a commercial electrospinning instrument NT-ESS-300, NTSEE Co. Ltd. South Korea with modified 3D printed collector. The processing parameters were: electrical voltage of 14-18 kV, flow rate of 1 mL/h and needle tip to collector distance of 18 cm. The geometry of the 3D printed collector is given in Figure 1. It consists of rectangular columns with

alternating heights of 0.6 and 1.2 mm. The geometry of the collector will provide the formation of loosen 3D fibrous scaffold structure.

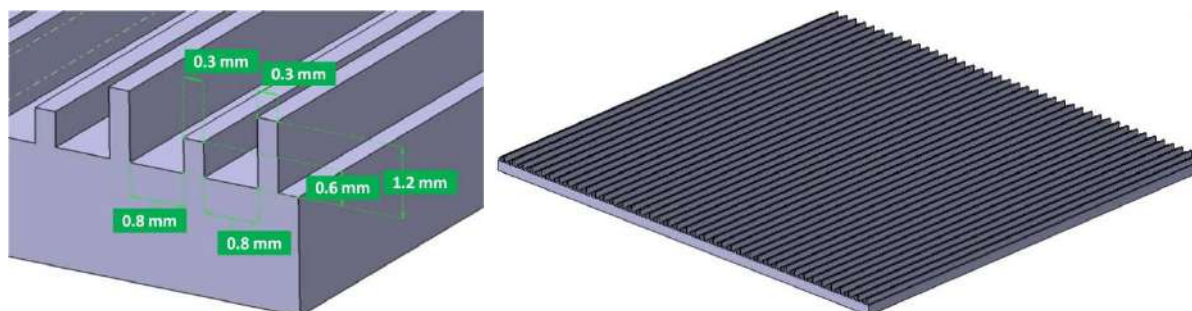

Figure 1. 3D printed collector with target geometry

#### *Scaffolds properties evaluation*

The electrospun scaffolds were evaluated for their morphology (SEM), including fibres and beads diameter, pores area and total porosity, water contact angle and mechanical behaviour (tensile testing). The fibres and beads diameters and pores areas were measured from the SEM images with *ImageJ* by 100 random measurements. The total porosity of the scaffolds was calculated according to the equation given elsewhere [8]. The water contact angle on the surface of the scaffolds was measured by the *ImageJ* Drop Analysis LB-ADSA tool from the images captured by DinoCaprute 2.0 microscope. The tensile tests were conducted in triplicates on a Tensile testing instrument Statimat M, Textechno with a load cell of 100 N, rate of 25 mm/min and gauge length of 75 mm.

## **RESULTS AND DISCUSSIONS**

Figure 2a and 2b gives some examples of the electrospun scaffolds morphology including the SEM images of the neat PCL and the PCL blended with the fibroin. Generally all the fibres in the electrospun scaffolds have smooth surfaces and cylindrical shapes with a random beads formation present in the neat PCL and the PCL/fibroin structure. The addition of the fibroin has resulted in the bead elongation and deformation, while in case of the antibiotic addition no beads were present.

Figures 3(a-c), gives the fibres and beads diameters as well as the pores area distributions of the electrospun PCL, PCL/CF and PCL/Fb scaffolds. The distribution of the fibres diameters was shifting with the addition of the fillers from 0-0.8 up to 0.6-2  $\mu\text{m}$ . The same effect was noticed for the pores area distributions as well, thus shifting from 0-4, to 0-6, to 1.5-16  $\mu\text{m}^2$  or even a few pores with the areas up to 34  $\mu\text{m}^2$ .



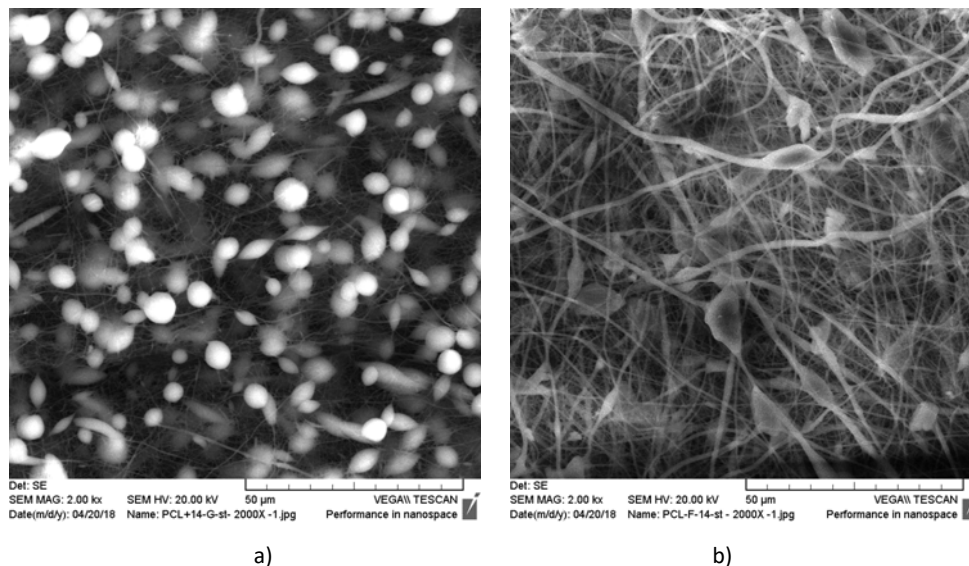

Figure 2. SEM images of some of the electrospun scaffolds.

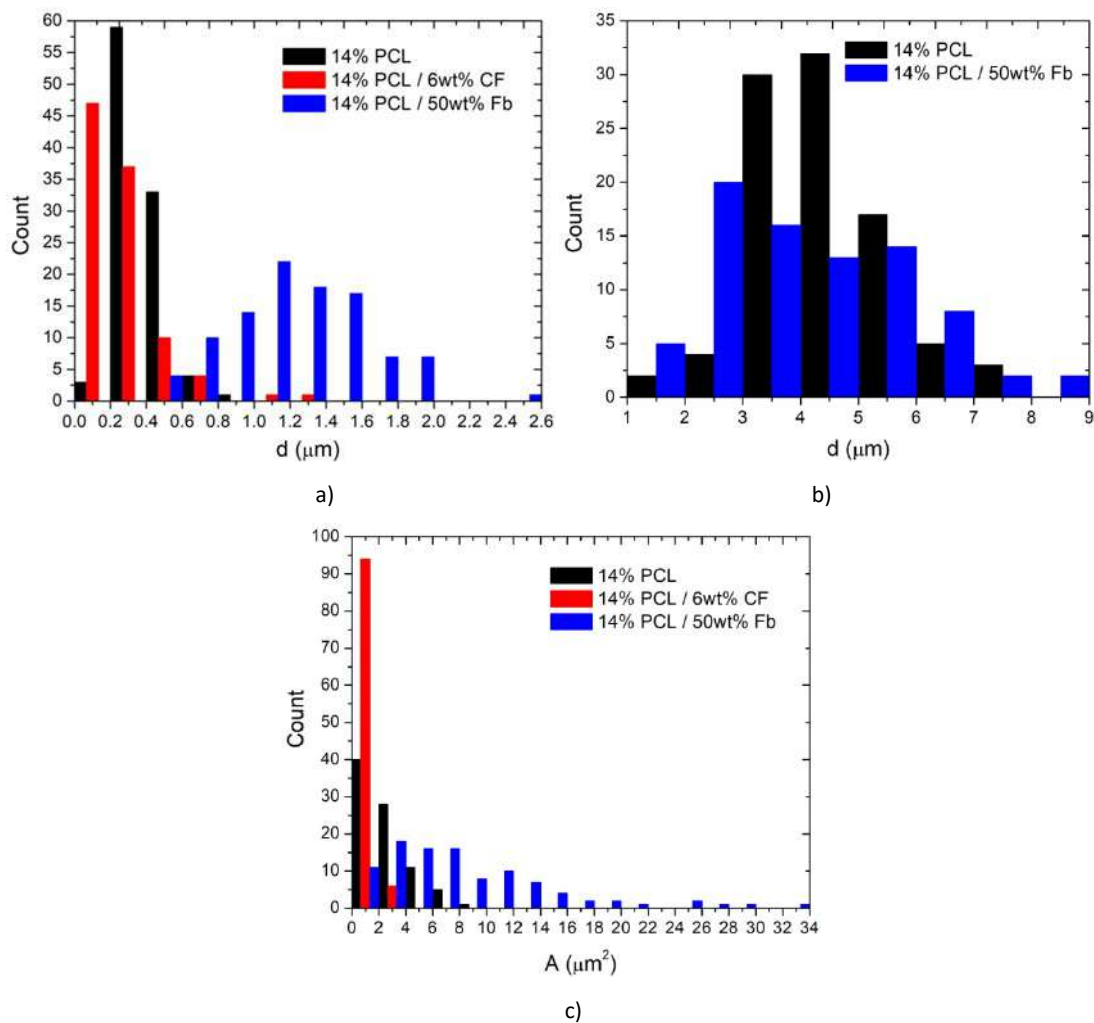

Figure 3. Fibers (a), beads (b) diameter and pores are (c) distribution of the electrospun scaffolds.

Table 1 gives the mean fibres, beads diameter and pores area as well as total porosity of the electrospun scaffolds. The diameters of the beads for the PCL and PCL/Fb showed small difference of less than 4% reduction with the addition of the filler. The mean fibres diameters of the PCL reduced and increased with the addition of the CF and the Fb from 376 to 270 nm and from 376 to 1219 nm, respectively. Analogue with the mean fibres diameters the pores areas showed the same trend, thus reduced with the addition of the antibiotic while increased with the fibroin addition by 0.6 % and 2.3 % respectively. It is interesting to notice how the porosity changes with the addition of the fillers and combined layers. Firstly, the modified collector produced high porosity 94.2 % of neat electrospun PCL, thus confirming the advantage of patterned collectors. The addition of the antibiotic reduced the total porosity to 91.7 %, which is in compliance with other studies thus the reduction of the fibres diameter results in porosity reduction due to high packaging density [9]. An opposite effect on the other hand was noticed for the 14% PCL / 50 wt% Fb where very large fibres diameters and pores areas did not result in higher porosity. Large pores area is certainly favourable for cells culture and colonization, but it should be further noticed that these results are coming from the scaffolds surface characteristics given by the SEM images. The same effect was further observed with the fabrication of scaffolds with both layers, 14% PCL / 50wt% Fb / 6wt% CF. This result suggests that the filler content should be set at a value that will not compromise largely the scaffold total porosity.

Figure 4 shows the water drops on the surface of the scaffolds with the measured angles. As expected both the antibiotic and the fibroin reduced the water contact angle around 90° immediately and much lower up to 47.6° for the 14% PCL / 6 wt% CF scaffold after 2 seconds.

Table 1. Mean fibers, beads diameter and pores area as well as total porosity of the electrospun scaffolds

Composites	$d_{\text{fibers}}$ ( $\mu\text{m}$ )	$d_{\text{beads}}$ ( $\mu\text{m}$ )	$A_{\text{pores}}$ ( $\mu\text{m}^2$ )	$A_{\text{sample}}$ ( $\text{cm}^2$ )	m (g)	h (cm)	P (%)
14% PCL	0.376±0.120	4.33±1.17	2.44±1.85	4.00	0.00720	0.02706	94.2
14% PCL / 6wt% CF	0.270±0.189	-	1.07±0.62	4.00	0.00805	0.02032	91.7
14% PCL / 50wt% Fb	1.219±0.384	4.16±1.63	8.13±6.45	4.00	0.01375	0.01950	81.2
14% PCL / 50wt% Fb / 6wt% CF	-	-	-	4.00	0.01770	0.01363	68.5

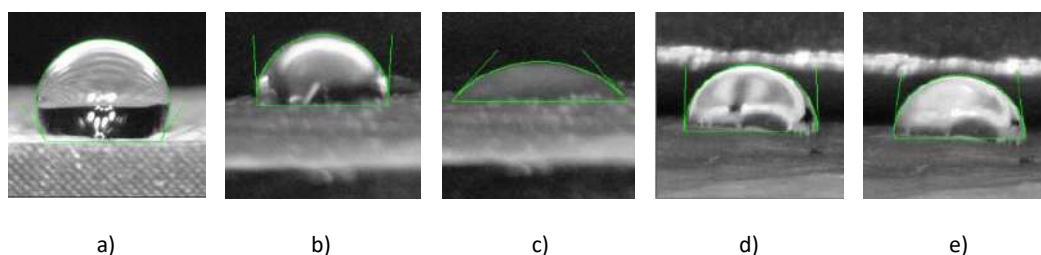

Figure 4. Water contact angle measurement on the surface of the electrospun: a) PCL, b) PCL / CF (after 0 seconds), c) PCL / CF (after 1-2 seconds), d) PCL / Fb (after 0 seconds), e) PCL / Fb (after 1-2 seconds)

The hydrophilic surface of the scaffolds is quite important for cells adhesion and further colonization.

Table 2. Electrospun scaffolds' water contact angles measured

Composites	Contact angle (°)	
	0 sec	1-2 sec
14% PCL	122.4	122.4
14% PCL / 6wt% CF	93.7	47.6
14% PCL / 50wt% Fb	87.8	82.5

Figure 5 shows the stress/strain tensile test of the electrospun scaffolds and Table 3 gives the maximum load, elongation and calculated tensile strength. Both the filler and layers affected the mechanical properties of the scaffolds. The addition of the fillers resulted in higher maximum load withstand thus increased the tensile strength from 65 cN/mm<sup>2</sup> by 288 % and 50% for the 14% PCL / 6 wt% CF and 14% PCL / 50 wt% Fb scaffolds, respectively.

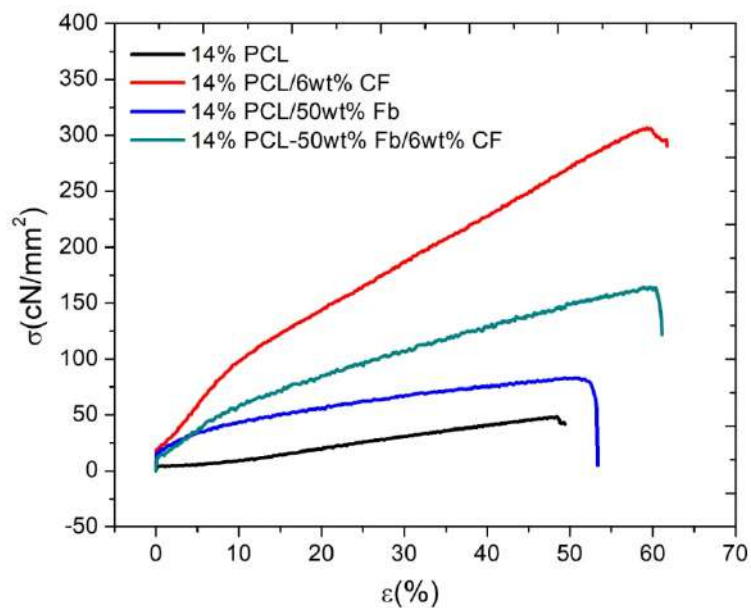

Figure 5. Stress/strain curves of the tensile tested electrospun scaffolds

Table 3. Maximum load, strain and tensile strength of the electrospun scaffolds

Composites	F (cN)	ε (%)	σ (cN/mm <sup>2</sup> )
14% PCL	177.67±84.35	50.42±8.29	65.66±31.17
14% PCL / 6wt% CF	529.00±123.00	57.00±19.71	260.33±60.53
14% PCL / 50wt% Fb	193.67±85.70	46.53±7.79	99.32±43.95
14% PCL / 50wt% Fb / 6wt% CF	291.67±172.74	57.25±5.13	213.99±126.76

The combination of both composition layers had the same effect with the increase of the tensile strength by 219 %. The changes in the maximum scaffolds elongation were not as significant thus all showing the values between 40-60 %. The increase in the scaffolds tensile strength with the addition of filler was reported elsewhere as well [10]. These results can vary depending on fillers wt% which is not in the scope of this study and also on the compatibility with the polymer matrix.

## CONCLUSIONS

In this study electrospun scaffolds were fabricated by fulfilling the aspect of adequate chemistry to attract cells better adhesion and spreading, tissue repair by introducing medical component and physical structure for cells guidance. The scaffolds were analysed in regard to their morphology, total porosity, surface wettability and tensile behaviour taking into account the type of filler and layered structure. The addition of the drug and the silk fibroin improved the hydrophilicity of the PCL surface and both reduced and increased the mean fibres diameter by 28% and 224%, respectively. Analogously the biggest pores area was in case of the PCL/fibroin of  $8.13 \pm 6.45 \mu\text{m}^2$ . Unexpectedly the total porosity of the scaffolds reduced with the addition of the filler and the combination of the two composition layers (from 94.2 to 68.5%). On the other hand, the addition of the filler and layers combination improved the tensile strength resulting in the maximum value of  $260.33 \pm 60.53 \text{ cN/mm}^2$ . These results suggest that the nature of the filler as well as scaffolds layers configuration affects the scaffolds properties and can be set depending on the requirements in tissue therapy and repair.

## Acknowledgements

This work has been fully supported by Croatian Science Foundation under the project IP-2016-06-6878, Custom Tailored Fibrous Scaffold Prototype for Tissue Cells Culture via Combined Electrospinning, COMBOELECTROSPUN.

## REFERENCES

- [1] Stevens MM, George JH, Exploring and Engineering the Cell Surface Interface. *Mater Biol* 2005; 310: 1135-1138
- [2] Mijović B, Tominac Trcin M, Agić A, Zdraveva E, Bujić M, Špoljarić I, Košec V. Study on Cell Adhesion Detection onto Biodegradable Electrospun PCL Scaffolds. *JFBI*. 2012; 5: 33-40
- [3] Lannutti J, Reneker D, Ma T, Tomasko D, Farson D. Electrospinning for tissue engineering scaffolds. *Mater Sci Eng C Mater Biol Appl*, 2007; 27: 3504-509
- [4] Lim YC, Johnson J, Fei Z, Wu Y, Farson DF, Lannutti JJ, Choi H, Lee LJ. Micropatterning and Characterization of Electrospun Poly(e-Caprolactone)/Gelatin Nanofiber Tissue Scaffolds by

- Femtosecond Laser Ablation for Tissue Engineering Applications. *Biotechnol Bioeng.* 2011; 108 (1): 116-126
- [5] Rogers CM, Morris GE, Gould TW, Bail R, Toumpaniari S, Harrington H, Dixon JE, Shakesheff KM, Segal J, Rose FR. A novel technique for the production of electrospun scaffolds with tailored three-dimensional micro-patterns employing additive manufacturing. *Biofabrication.* 2014; 6(3): 1-11
- [6] Lee J, Lee SY, Jang J, Jeong YH, Cho D-W. Fabrication of Patterned Nanofibrous Mats Using Direct-Write Electrospinning. *Langmuir.* 2012; 28 (18): 7267-7275
- [7] Faccendini A, Vigani B, Rossi S, Sandri G, Bonferoni MC, Caramella CM, Ferrari F. Nanofiber Scaffolds as Drug Delivery Systems to Bridge Spinal Cord Injury. *Pharmaceuticals* 2017; 10(3): doi:10.3390/ph10030063
- [8] Zdraveva E, Mijović B, Govorcin Bajsić E, Dekaris I, Zubin Ferri T, Čipčić T. Morfološke karakteristike nanovlaknastog materijala u ovisnosti o koncentraciji punila, *Proceedings, RIM 2017 – Development and Modernization of Production*, Hodžić A, Omer SE, Hodžić D (eds.). Sarajevo: Univerzitet u Bihaću, Tehnički fakultet, 2017; 543-548.
- [9] Bai L, Li Q, Duo X, Hao X, Zhang W, Shi C, Guo J, Ren X, Feng Y. Electrospun PCL-PIBMD/SF blend scaffolds with plasmid complexes for endothelial cell proliferation. *RSC Adv.* 2017; 7: 39452-39464
- [10] Shanmugavel S, Reddy VJ, Ramakrishna S, Lakshmi BS, Dev GVR. Precipitation of hydroxyapatite on electrospun polycaprolactone/aloe vera/silk fibroin nanofibrous scaffolds for bone tissue engineering. *J Biomater Appl.* 2014; 29: 46-57

# COMPRESSIONAL BEHAVIOUR OF NONWOVEN FABRICS

Petar VIDAKOVIĆ<sup>1</sup>, Dragana KOPITAR<sup>1\*</sup>

<sup>1</sup>University of Zagreb, Faculty of Textile Technology, Prilaz baruna Filipovića 28a, 10000 Zagreb, Croatia, \*email: dragana.kopitar@ttf

---

## ABSTRACT

*Nonwoven fabrics are used in a number of technical applications since they have versatile physical-mechanical properties. The compressional and recovery behaviour is an important mechanical property which could predict nonwoven fabrics behaviour in real use. The tested samples are produced of polypropylene fibres by mechanical carding process and bonded by needle punching (mass per unit area was in range from 155 g m<sup>-2</sup> to 470 g m<sup>-2</sup>), nonwoven fabric of polypropylene fibres produced by mechanical carding process, bonded by needling and calendaring process (in range of 200 g m<sup>-2</sup> to 480 g m<sup>-2</sup>), following by nonwoven fabric of polyester fibres and produced by carding process, bonded by thermal process (in range of 275 g m<sup>-2</sup> to 525 g m<sup>-2</sup>). Samples produced from regenerated (270 g m<sup>-2</sup>) and coconut fibres (980 g m<sup>-2</sup>) by mechanical carding process and bonded by needle punching as well as moulded polyurethane foam (180 g m<sup>-2</sup>) were tested. Compressional properties of the nonwoven fabrics are determined using Hess Thickness Gauge. Using Thickness Gauge, nonwoven fabrics thickness according to standard ISO 9073-2:1995 (under pressures of 0.1 and 0.5 kPa) was determined. Additionally, compression study by increasing pressures (from 0 kPa, 0.5 kPa, 1.0 kPa to 49.5 kPa) and then decreasing (from 49.5 kPa, 1.0 kPa, 0.5 kPa to 0 kPa) different nonwoven fabrics compression and recovery values as well as compressional curves were obtained and valuated. A comparative study on the compressional behaviour of different nonwoven fabrics was reported. The compressibility of needle punched nonwoven fabrics is higher than needle punched and calendared nonwoven fabrics. The polyester nonwoven fabric produced by carding process and bonded by thermal process shows greatest compressibility.*

## KEYWORDS

*Nonwoven fabrics, thickness, compressibility, thickness loss*

---

## INTRODUCTION

The compression property is one of the most important properties of nonwoven fabrics used in the technical applications. The nonwoven fabrics are used in various technical and industrial fields and providing specific functions such as absorbency, resilience, stretch, softness, strength, cushioning, thermal insulation, acoustic insulation, filtration etc. In technical and industrial field nonwoven are often subjected to compressional load, which effects on their properties.

The nonwoven fabrics consist of loose fibre mass where compressibility is defined as the percentage reduction in volume of the fibre mass, resulting from a specified increase of applied pressure [1]. A nonwoven fabrics consist of fibre assembly (lose fibre mass) which are in mutual contact forming contact points. The contact points determine the average free fibre length which will bend during applied compression. It should be mentioned that there are frictional interactions at the contact points [2]. The number of fibres contacts increased linearly with the nonwoven fabric density. At higher

nonwoven fabric densities, the number of contacts increased at a constantly increasing rate. The contact points and free fibres lengths effect on compressional behaviour, where fibre orientation in the web should be taken into account. The orientation can be randomly orientated in the fabric plane or orientated in machine direction (MD) and cross machine direction (CD) [3].

On compression behaviour of jute/polypropylene and polyester nonwoven fabrics, fibre linear density, blend ratios of fibres, fabric weight, web laying type, needling density and depth of needle penetration influenced [1, 4]. The compression behaviour of polyester and polypropylene needle-punched nonwoven fabrics depends on fibre fineness, proportion of finer fibre present in different layers of nonwoven fabrics, and fabric weight [5, 6].

The effect of rate of compression and recovery, number of compression-recovery cycles and size of the pressure foot on the compression behaviour of different nonwoven fabrics was investigated. Study shows that nonwoven fabrics rate of deformation increases, where due to frequent compression of nonwoven fabrics their compressibility decreases. The compressibility and initial thickness of nonwoven fabrics decreases sharply after the first compression cycle, where after a few cycles these parameters remain unchanged [7].

Better compression characteristics of needled nonwoven fabric can be achieved by better consolidation (bonding). Nonwoven fabric bonding can be improved by increasing the depth of needle penetration or needling density [8-11].

Cross-laid nonwoven fabric structures show higher compressibility and lower recovery after applied pressure compared to parallel laid nonwoven fabrics [12]. In same study was found that finer fibre fineness and parallel laid webs led to better nonwoven fabric consolidation.

The present study highlights the effects of fabric weight, thickness and bonding processes on the compression properties (initial thickness, percentage compression, percentage thickness loss) of needle punched nonwoven fabrics.

## **EXPERIMENTAL**

### **Materials and Methods**

#### *Nonwoven fabrics*

Samples are produced from polypropylene, polyester, coconut and regenerated fibres as well from polyurethane polymer. Except polyurethane foam (mass per unit area of  $184 \text{ g m}^{-2}$ ), which are produced by extrusion and moulding, samples webs are produced by mechanical process on carding machine. Part of polypropylene (mass per unit area was in range from  $155 \text{ g m}^{-2}$  to  $470 \text{ g m}^{-2}$ ), polyester (in range of  $275 \text{ g m}^{-2}$  to  $525 \text{ g m}^{-2}$ ) and coconut ( $983 \text{ g m}^{-2}$ ) webs are bonded by needle punching,

where part of polypropylene webs are bonded by needle punching and calendaring (in range of 200 g m<sup>-2</sup> to 480 g m<sup>-2</sup>). One polyester web is bonded by thermal process (199 g m<sup>-2</sup>). Altogether, 17 different samples are tested (Table 1.).

Table 1. Nonwoven fabrics fibre and production process

No.	Sample mark	Fibre	Web production process	Bonding process
1.	PP-1	polypropylene	carding	needle punching
2.	PP-2	polypropylene	carding	needle punching
3.	PP-3	polypropylene	carding	needle punching
4.	PP-4	polypropylene	carding	needle punching
5.	PP-5	polypropylene	carding	needle punching
6.	PP 6	polypropylene	carding	needle punching
7.	PPC-1	polypropylene	carding	needle punching and calendaring
8.	PPC-2	polypropylene	carding	needle punching and calendaring
9.	PPC-3	polypropylene	carding	needle punching and calendaring
10.	PPC-4	polypropylene	carding	needle punching and calendaring
11.	PES-1	polyester	carding	needle punching
12.	PES-2	polyester	carding	needle punching
13.	PES-3	polyester	carding	needle punching
14.	R-1	regenerate	carding	needle punching
15.	W-PES-1	polyester	carding	thermally (hot air)
16.	F-PU-1	polyurethane	extrusion	moulding
17.	N	coconut	carding	needle punching

The process parameters of the three groups of samples, polypropylene nonwoven fabric produced on card and bonded by needle punching (PP group), polypropylene nonwoven fabric produced on card and bonded by needle punching and calendaring (PPC) and polyester nonwoven fabric produced on card and bonded by needle punching (PES) are given in Table 2. Polypropylene (PP and PPC group) and polyester fibres (PES group) were same, considering fibre fineness and length.



Table 2. The process parameters of the nonwoven fabrics

The polypropylene nonwoven fabrics pre-needling and needling processes parameters						
Sample	PP-1	PP-2	PP-3	PP-4	PP-5	PP-6
Pre-needling						
Number of needle strokes per area, strokes/cm <sup>2</sup>	600	600	600	600	600	591
Depth of needle penetration, mm	7.5	7.5	7.5	7.5	7.5	7.0
Needling						
Number of needle strokes per area, strokes/cm <sup>2</sup>	370	370	370	380	380	385
Depth of needle penetration, mm	4.0	4.0	4.0	3.4	3.4	3.4
The polypropylene nonwoven fabrics calendaring process parameters (PPC-1, PPC-2, PPC-3, PPC-4)						
Calendering temperature, °C	140					
Calender pressure rollers, 40 daN/cm	40					
The polyester nonwoven fabrics pre-needling and needling processes parameters						
Sample	PES-1	PES-2	PES-3			
Pre-needling						
Number of needle strokes per area, strokes/cm <sup>2</sup>	600	600	591			
Depth of needle penetration, mm	7.5	7.5	7.0			
Needling						
Number of needle strokes per area, strokes/cm <sup>2</sup>	370	370	385			
Depth of needle penetration, mm	4.0	4.0	3.4			

#### *Thickness and compressional measurements*

Thickness of samples on the Hess Thickness Gauge according to standard ISO 9073-2:1995, measured under the pressures of 0.5 kPa and 1.0 kPa with a pressure foot of 2 cm diameter were obtained.

For compressional study same device was used. Compressional study was conducted by following procedure. The pressure foot without weight is pressed on nonwoven fabric for 30 seconds where the initial thickness ( $T_0$ ) is recorded. The pressure was increased in steps, respectively with 0.5 kPa, 1.0 kPa and 49.5 kPa. After every step of pressure increase, 30 seconds were waited and thickness was recorded. After reaching a pressure of 49.5 kPa, i.e. the final pressure, the pressure is gradually reduced in steps, waited 30 seconds after every step of pressure decrease to record thickness values (so called recovery cycle). For each sample, tests were carried out at ten different places.

Nonwoven fabric density is the mass per unit volume of the nonwoven fabric in g cm<sup>-3</sup> [13]. Nonwoven fabric density is calculated according to the following equation:

$$\rho = \frac{M}{T} \quad (1)$$

where  $M$  is nonwoven mass per unit area in g cm<sup>-2</sup> and  $T$  is nonwoven thickness in cm.

Porosity can be obtained by the ratio of the nonwoven fabric density and the fibre density [13]

$$P = \left(1 - \frac{\rho_{\text{nonwoven fabric}}}{\rho_{\text{fibre}}}\right) \times 100 \quad (2)$$

Where  $P$  is porosity in %,  $\rho_{\text{nonwoven fabric}}$  is fabric density in  $\text{g cm}^{-3}$  and  $\rho_{\text{fibre}}$  is the fibre density in  $\text{g cm}^{-3}$  whereas polypropylene fibre density is  $0.91 \text{ g cm}^{-3}$ , polyester fibre density is  $1.39 \text{ g cm}^{-3}$ , coconut fibre density is  $0.90 \text{ g cm}^{-3}$ , and polyurethane foam density is  $1.0 \text{ g cm}^{-3}$ .

Compression percentage was estimated using following equation [14]:

$$C = \left(\frac{T_0 - T_{49.5}}{T_0}\right) \times 100 \quad (3)$$

where  $T_0$  is the initial thickness in mm and  $T_{49.5}$  is thickness under maximum pressure of 49.5 kPa

Percentage thickness loss was calculated following equation [14]:

$$C_L = \left(\frac{T_0 - T_0^*}{T_0}\right) \times 100 \quad (4)$$

where  $T_0$  is the initial thickness in mm and  $T_0^*$  is the final fabric thickness obtained by decreasing the pressure to 0 kPa in mm

## RESULTS AND DISCUSSIONS

Nonwoven fabrics mass per unit area and thickness according to standard ISO 9073-2:1995 (measured under pressures of 0.1 and 0.5 kPa) with statistical indicator are given in Table 3. The nonwoven fabric uniformity is defined as the fabric mass per unit area and/or fabric density distribution in the fabric structure. The basic statistical indicators of nonwoven fabric uniformity are the standard deviation and the coefficient of variation of measured parameters (fabric weight, fabric thickness, fabric density etc.) [13].

The mass per unit are of the samples are in the range from  $150 \text{ g m}^{-2}$  to  $983 \text{ g m}^{-2}$ . The nonwoven fabrics thickness measured by 0.1 kPa are in the range from 1.31 mm to 11.18 mm, while under pressure of 0.5 kPa are in the range of 1.00 mm to 9.78 mm. The nonwoven fabrics thicknesses due to change of pressure from 0.1 kPa to 0.5 kPa are differently reduced. The nonwoven fabrics thicknesses reduction are in the range of 0.6 % (polyurethane foam, F-PU-1) to 29.1 % (polyester nonwoven thermally bonded, W-PES-1). Statistic indicators are relatively high, but acceptable for nonwoven fabric structures.

Observing nonwoven fabrics by groups (PP, PPC and PES), thickness of nonwoven fabrics measured under pressure of 0.1 kPa and 0.5 kPa increase with the increase of nonwoven fabric mass per unit areas.

Table 3. Nonwoven fabric mass per unit area and thickness

Sample	M, g m <sup>-2</sup>	SD, g m <sup>-2</sup>	CV, %	T <sub>0.1</sub> , mm	SD, mm	CV, %	T <sub>0.5</sub> , mm	SD, mm	CV,%
PP-1	150	0.01	0.19	3.24	0.08	2.58	2.98	0.08	2.74
PP-2	204	0.44	4.26	3.85	0.95	2.47	3.54	0.10	2.74
PP-3	258	0.45	3.49	4.39	0.37	8.41	3.95	0.15	3.85
PP-4	332	0.41	2.44	4.73	0.20	4.13	4.34	0.13	3.03
PP-5	382	0.60	3.15	4.98	0.19	3.87	4.62	0.14	3.09
PP 6	467	0.75	3.22	5.31	0.25	4.77	4.89	0.18	3.57
PPC-1	214	0.40	3.69	1.31	0.39	10.18	1.00	0.11	11.22
PPC-2	226	0.23	2.06	1.34	0.05	3.79	1.17	0.05	4.29
PPC-3	342	0.04	0.24	2.02	0.11	5.40	1.82	0.08	4.51
PPC-4	476	0.61	2.58	2.83	0.15	5.35	2.43	0.09	3.77
PES-1	275	1.27	8.24	2.88	0.17	5.85	2.25	0.22	9.59
PES-2	307	0.61	4.45	3.47	0.18	5.19	2.93	0.14	4.94
PES-3	525	1.84	6.99	4.63	0.46	9.87	3.50	0.18	5.06
R-1	269	0.07	0.50	2.19	0.18	8.09	1.83	0.11	6.27
W-PES-1	199	0.71	7.17	11.18	0.97	8.69	7.93	1.20	15.14
F-PU-1	184	0.10	1.09	9.84	0.20	2.00	9.78	0.05	0.53
N	983	3.82	7.78	9.65	1.18	12.24	8.30	0.62	7.42

where M is the mass per unit area of nonwoven fabric in g m<sup>-2</sup>; T<sub>0.1</sub> is the nonwoven fabric thickness under pressure of 0.1 kPa in mm; T<sub>0.5</sub> is the nonwoven fabric thickness under pressure of 0.5 kPa in mm; SD is standard deviation in mm; CV is coefficient of variation, %

In table 3 and table 4 nonwoven fabrics thickness change by increasing and then decreasing pressures (starting from 0.0 kPa, increasing to 0.5 kPa, 1.0 kPa, 49.5 kPa and then decreasing in reverse order) are presented. Compression and decompression curves of the nonwoven fabrics are given on figures 1-4.

The values of thickness measured under same pressure (0.5 kPa) but with different procedures (thickness measured according to standard ISO 9073-2:1995 under pressure of 0.5 kPa presented in table 3 and thickness obtained during increasing and decreasing pressures in steps presented in table 4 and 5) differ because of the different measurement procedure itself.

Table 4. Nonwoven fabric thickness change obtained by increasing the pressure (compression and decompression cycle)

Sample	T <sub>0</sub> ,	SD,	CV,	T <sub>0.5</sub> ,	SD,	CV,	T <sub>1.0</sub> ,	SD,	CV,	T <sub>49.5</sub> ,	SD,	CV,
PP-1	3,35	0,11	3,14	3,10	0,06	1,77	2,99	0,03	1,08	2,82	0,03	0,94
PP-2	3,84	0,12	3,00	3,58	0,06	1,64	3,48	0,06	1,85	3,30	0,03	0,80
PP-3	4,14	0,17	4,22	3,87	0,12	3,18	3,74	0,13	3,39	3,58	0,10	2,65
PP-4	4,66	0,04	0,75	4,35	0,01	0,27	4,26	0,04	0,85	4,10	0,04	0,98
PP-5	5,22	0,04	0,77	4,88	0,10	2,05	4,77	0,10	2,00	4,61	0,11	2,39
PP-6	5,38	0,09	1,58	5,03	0,02	0,41	4,89	0,07	1,34	4,74	0,07	1,37
PPC-1	0,97	0,14	11,61	0,90	0,16	15,33	0,87	0,16	15,78	0,85	0,14	15,15
PPC-2	1,40	0,05	3,42	1,31	0,03	2,59	1,27	0,04	3,19	1,23	0,03	2,81
PPC-3	2,02	0,04	1,74	1,88	0,05	2,47	1,83	0,04	2,07	1,79	0,04	1,99
PPC-4	2,35	0,15	5,48	2,23	0,09	3,62	2,19	0,08	3,52	2,15	0,07	2,69
PES-1	2,76	0,06	2,13	2,38	0,03	1,28	2,25	0,04	1,85	2,04	0,08	3,96
PES-2	3,60	0,29	7,93	3,06	0,06	1,96	2,86	0,09	3,25	2,63	0,08	2,85
PES-3	4,20	0,22	5,23	3,63	0,17	4,70	3,38	0,12	3,60	3,19	0,09	2,79
R-1	2,22	0,08	3,58	1,97	0,12	5,85	1,86	0,11	5,69	1,85	0,12	7,02
W-PES-1	11,11	0,62	5,57	7,67	0,90	11,70	6,32	1,10	17,46	5,12	0,63	12,29
F-PU-1	9,93	0,02	0,15	9,86	0,01	0,10	9,83	0,01	0,06	9,77	0,01	0,06
N	9,60	0,85	8,87	8,36	0,82	9,76	8,01	0,73	9,15	7,56	0,66	8,77

where T<sub>0</sub> is the initial fabric thickness obtained without pressure in mm; T<sub>0.5</sub> is the fabric thickness under pressure of 0.5 kPa obtained by decreasing the pressure from 0.0 kPa to 0.5 kPa in mm; T<sub>1</sub> is the fabric thickness under pressure of 1.0 kPa obtained by decreasing the pressure from 0.5 kPa to 1.0 kPa in mm; T<sub>49.5</sub> is the fabric thickness under pressure of 49.5 kPa obtained by decreasing the pressure from 1.0 kPa to 49.5 kPa in mm; SD is standard deviation in mm; CV is coefficient of variation, %.

The thickness of polypropylene nonwoven fabric bonded by needle punching (PP group), needle punching and calendaring (PPC) and needle punched polyester group (PES) decrease by pressure increase and vice versa, increase by pressure decrease (Table 4 and 5; Figures 1-3).

Changes of thickness by increasing and afterward decreasing pressure are greater for nonwoven fabrics of lower masses per unit area, i.e. thickness change decrease with increase of nonwoven fabric mass per unit area. The nonwoven fabric mass per unit area and thickness determine fabric packing density, i.e. porosity of the fabric. Porosity is defined as the ratio of the fibres to the total volume of the nonwoven fabric. Nonwoven fabric porosity influences on the freedom of fibre movements within nonwoven fabric. The nonwoven fabric of greater mass per unit area have greater fabric density, thus fabric is less porous and movement of fibres within structure is less freely, resulting in smaller nonwoven fabric thickness change (Table 4, Table 5). The polypropylene nonwoven fabrics (PP group) change of thickness by increasing and decreasing pressures are described by logarithm regression curve and equations with high correlation coefficient (0.99).

During calendaring process, a web is passes through the heated calendar rollers which are under pressure. By the influence of calendar rollers temperature and pressure in defined time, thermoplastic fibres in the web get close to each other, partially soften and bonded with each other at the bonding

points (intersection of the fibres). The polypropylene nonwoven fabrics bonded by needle punching were additionally bonded by calendaring (calendaring process parameters are given in Table 2). The calendaring process decreased thickness of polypropylene nonwoven fabrics related to only needle punched samples (Table 3). Comparing thickness change of calendared samples related to only needle punched nonwoven fabrics during compression and decompression cycle (pressure increase and decrease), less thickness change of calendared samples is visible. Result of calendaring process is more compact fabric structure, i.e. greater density and less porous nonwoven fabric comparing to only needle punched (Table 7). Because of more compact structure of calendared fabrics, less thickness change due to compression and decompression cycles occur (Table 4, Table 5). The calendared polypropylene nonwoven fabrics (PPC group) change of thickness by increasing and decreasing pressures are described by logarithm regression curve and equations with high correlation coefficient (Table 6).

Table 5. Nonwoven fabric thickness change obtained by decreasing the pressure (compression and decompression cycle)

Sample	$T_{49.5}^*$	SD,	CV,	$T_{1.0}^*$	SD,	CV,	$T_{0.5}^*$	SD,	CV,	$T_0^*$	SD,	CV,
PP-1	2,82	0,03	0,94	2,92	0,03	1,10	2,98	0,04	1,40	3,11	0,05	1,48
PP-2	3,30	0,0	0,80	3,38	0,06	1,63	3,45	0,06	1,65	3,61	0,08	2,20
PP-3	3,58	0,10	2,65	3,66	0,10	2,62	3,72	0,12	3,02	3,89	0,13	3,31
PP-4	4,10	0,04	0,98	4,19	0,04	0,95	4,25	0,03	0,71	4,40	0,05	1,04
PP-5	4,61	0,11	2,39	4,69	0,11	2,24	4,75	0,11	2,21	4,91	0,09	1,76
PP 6	4,74	0,07	1,37	4,85	0,11	2,20	4,89	0,06	1,28	5,06	0,07	1,40
PPC-1	0,83	0,14	15,15	0,86	0,15	15,86	0,87	0,15	15,25	0,92	0,16	15,09
PPC-2	1,21	0,03	2,81	1,24	0,04	2,96	1,28	0,04	3,00	1,34	0,03	2,56
PPC-3	1,75	0,04	1,99	1,80	0,05	2,62	1,83	0,04	2,05	1,94	0,04	2,26
PPC-4	2,11	0,07	2,69	2,16	0,08	3,46	2,17	0,08	3,43	2,27	0,10	4,04
PES-1	2,04	0,08	3,96	2,17	0,07	2,99	2,28	0,05	2,19	2,57	0,05	1,78
PES-2	2,63	0,08	2,85	2,78	0,10	3,43	2,91	0,08	2,77	3,28	0,02	0,61
PES-3	3,19	0,09	2,79	3,33	0,10	3,14	3,45	0,13	3,77	3,91	0,10	2,67
R-1	1,85	0,12	7,02	1,82	0,11	6,19	1,89	0,10	5,52	2,08	0,10	4,92
W-PES1	5,12	0,63	12,29	6,38	0,68	10,62	7,52	0,71	9,40	10,03	0,80	7,93
F-PU-1	9,77	0,01	0,06	9,82	0,01	0,06	9,85	0,01	0,06	9,90	0,01	7,93
N	7,56	0,66	8,77	7,85	0,72	9,16	8,08	0,73	9,05	8,79	0,73	8,26

where  $T_{49.5}^*$  is the fabric thickness under pressure of 49.5 kPa in mm;  $T_{1.0}^*$  is the fabric thickness under pressure of 1.0 kPa obtained by decreasing the pressure from 49.5 kPa to 1.0 kPa in mm;  $T_{0.5}^*$  is the fabric thickness under pressure of 0.5 kPa obtained by decreasing the pressure from 1.0 kPa to 0.5 kPa in mm;  $T_0^*$  is the final fabric thickness obtained by decreasing the pressure from 0.5 kPa to 0 kPa in mm; SD is standard deviation in mm; CV is coefficient of variation, %

Influence of the fibre type and parameters on compressibility comparing needle punched polypropylene (PP group) and polyester group (PES group) of nonwoven fabrics is visible (Table 4, Table 5). Fibre parameters (density, fineness, length, cross-section, crimp, surface) influence on freedom of their movement inside the fabric structure thus influence on fabric compressibility. The nonwoven needle punched polyester fabrics density is greater while porosity is lower, comparing to polypropylene needle punched nonwoven fabrics. Fabric density and porosity influenced on thickness change of the compression and decompression cycles (Table 4, Table 5). The thickness change of polyester nonwoven fabrics as result of pressure increase and decrease are described by logarithm regression curve and equations with high correlation coefficient.

Greatest thickness change of compression and decompression cycle have polyester nonwoven fabric bonded by hot air (W-PES-1), while lowest is noticed for polyurethane foam (F-PU-1). The polyurethane foam (F-PU-1) have almost same logarithm regression coefficients of compression and decompression cycle with very strong relationship ( $r=0.99$ ) between thickness and pressure (Table 6, Figure 4).

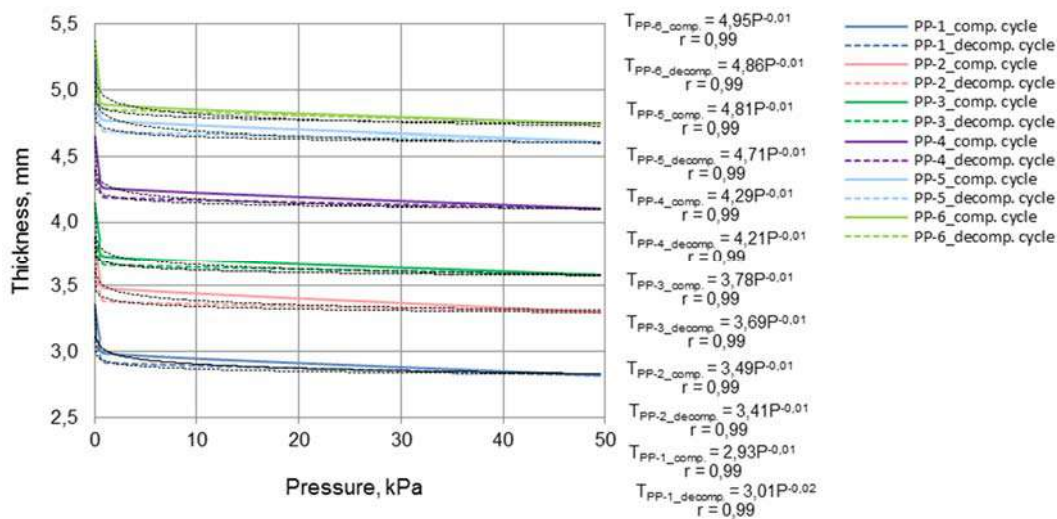

Figure 1. Needle punched polypropylene nonwoven fabric thickness depending on the applied pressures (0 kPa, 0.5 kPa, 1.0 kPa and 49.5 kPa)

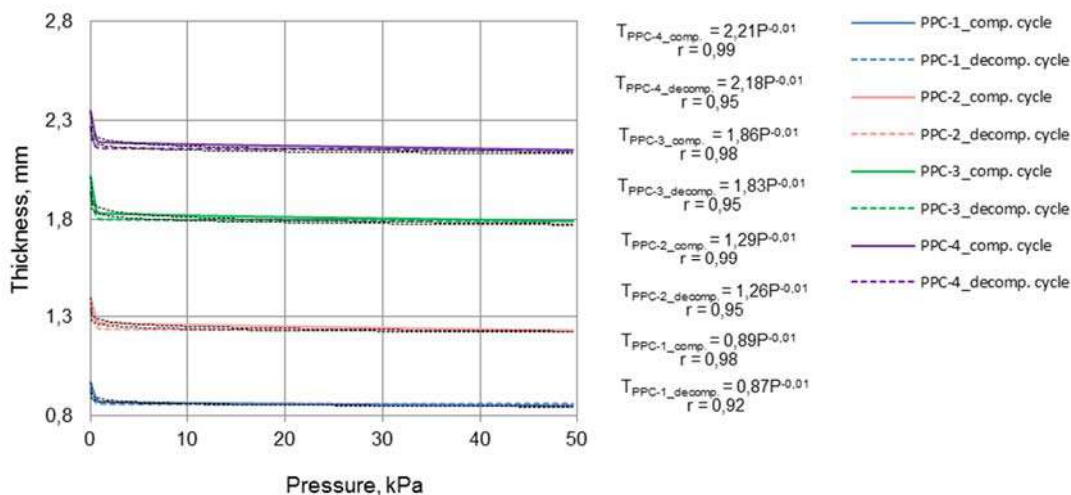

Figure 2. Needle punched and calendared polypropylene nonwoven fabric thickness depending on the applied pressures (0 kPa, 0.5 kPa, 1.0 kPa and 49.5 kPa)

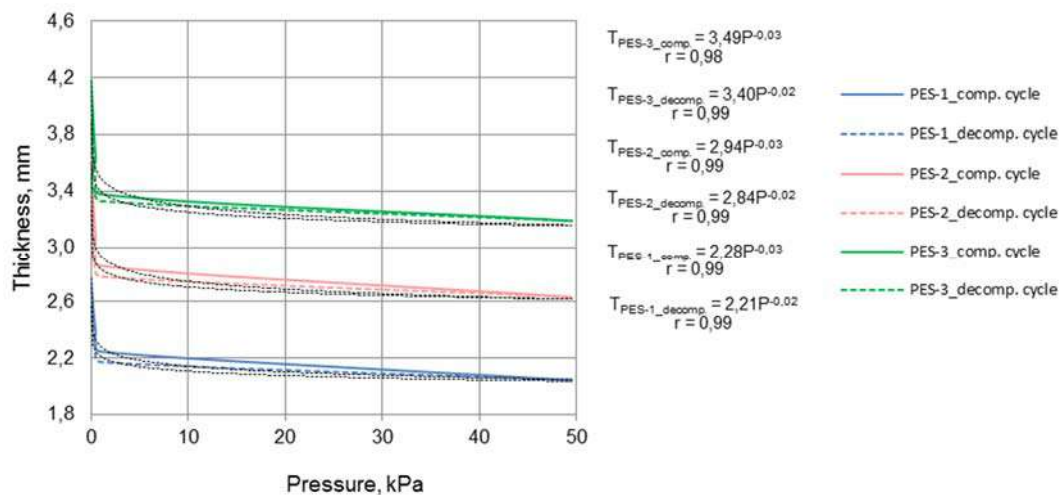

Figure 3. Needle punched polyester nonwoven fabric thickness depending on the applied pressures (0 kPa, 0.5 kPa, 1.0 kPa and 49.5 kPa)

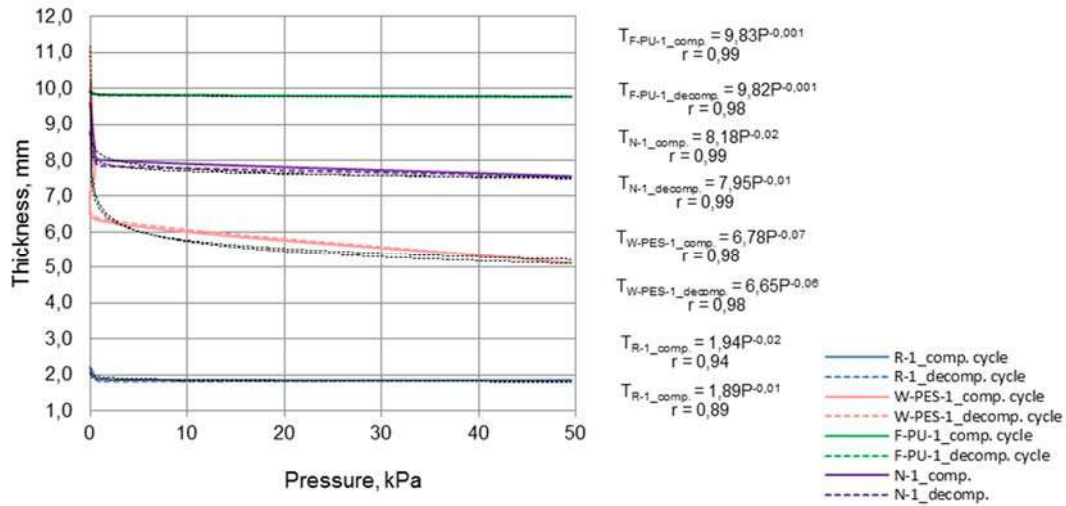

Figure 4. Regenerated, coconut and thermally bonded polyester nonwoven fabric as well polyurethane foam thickness depending on the applied pressures (0 kPa, 0.5 kPa, 1.0 kPa and 49.5 kPa)

Percentage difference of initial thickness (before pressure increase,  $T_0$ ) and thickness under greatest pressure (49.5 kPa) are described by compression percentage (Table 7). The compression percentage of PP group (in the range of 11.9% to 15.8%), PPC group (in the range of 8.5% to 12.4%) and PES group (in the range of 24.0% to 26.9%) decrease with increase of mass per unit area.



Table 6. Logarithm regression equation and correlation coefficient of nonwoven fabric compression and decompression cycle

Sample	Compression cycle				Decompression cycle			
	Logarithm regression	r	a	b	Logarithm regression	r	a	b
PP-1	$y = 2.93x^{-0.01}$	0.99	2.93	-0.01	$y = 3.01x^{-0.02}$	0.99	3.01	-0.01
PP-2	$y = 3.49x^{-0.01}$	0.99	3.49	-0.01	$y = 3.41x^{-0.01}$	0.99	3.41	-0.01
PP-3	$y = 3.78x^{-0.01}$	0.99	3.78	-0.01	$y = 3.69x^{-0.01}$	0.99	3.69	-0.01
PP-4	$y = 4.29x^{-0.01}$	0.99	4.29	-0.01	$y = 4.21x^{-0.01}$	0.99	4.21	-0.01
PP-5	$y = 4.81x^{-0.01}$	0.99	4.81	-0.01	$y = 4.71x^{-0.01}$	0.99	4.71	-0.01
PP-6	$y = 4.95x^{-0.01}$	0.99	4.95	-0.01	$y = 4.86x^{-0.01}$	0.99	4.86	-0.01
PPC-1	$y = 0.89x^{-0.01}$	0.98	0.89	-0.01	$y = 0.87x^{-0.01}$	0.92	0.87	-0.01
PPC-2	$y = 1.29x^{-0.01}$	0.99	1.29	-0.01	$y = 1.26x^{-0.01}$	0.95	1.26	-0.01
PPC-3	$y = 1.86x^{-0.01}$	0.98	1.86	-0.01	$y = 1.83x^{-0.01}$	0.95	1.83	-0.01
PPC-4	$y = 2.21x^{-0.01}$	0.99	2.21	-0.01	$y = 2.18x^{-0.01}$	0.95	2.18	-0.01
PES-1	$y = 2.28x^{-0.03}$	0.99	2.28	-0.03	$y = 2.21x^{-0.02}$	0.99	2.21	-0.02
PES-2	$y = 2.94x^{-0.03}$	0.99	2.94	-0.03	$y = 2.84x^{-0.02}$	0.99	2.84	-0.02
PES-3	$y = 3.49x^{-0.03}$	0.98	3.49	-0.03	$y = 3.40x^{-0.02}$	0.99	3.40	-0.02
R-1	$y = 1.94x^{-0.02}$	0.94	1.94	-0.02	$y = 1.89x^{-0.01}$	0.89	1.89	-0.01
W-	$y = 6.78x^{-0.07}$	0.98	6.78	-0.07	$y = 6.65x^{-0.06}$	0.98	6.65	-0.06
F-PU-1	$y = 9.83x^{-0.001}$	0.99	9.83	-	$y = 9.82x^{-0.001}$	0.98	9.82	-
N	$y = 8.18x^{-0.02}$	0.99	8.18	-0.02	$y = 7.95x^{-0.01}$	0.99	7.95	-0.01

Legend: Logarithm regression equation is in the form  $y = a x^b$ , where  $x$  variable is the pressure,  $y$  variable is the thickness;  $a$  and  $b$  are logarithm regression coefficients,  $r$  is the correlation coefficient.

Comparing polypropylene and polyester nonwoven fabrics similar mass per unit area bonded by needle punching (PP-3 with PES-1, PP-4 with PES-2 and PP-6 with PES-3), i.e. nonwoven fabrics produced by same technology, influence of the fibre type and parameters as well production parameters on compression percentage is noticeable.

Table 7. Nonwoven fabric density, porosity and compression

Sample	$\rho$ , g cm <sup>-3</sup>	P, %	C, %	C <sub>L</sub> , %
PP-1	0.045	95.1	15.8	7.2
PP-2	0.053	94.2	14.1	6.0
PP-3	0.062	93.2	13.5	6.0
PP-4	0.071	92.2	12.0	5.6
PP-5	0.073	92.0	11.7	5.9
PP 6	0.087	90.5	11.9	5.9
PPC-1	0.177	80.6	12.4	5.2
PPC-2	0.169	81.5	12.1	4.3
PPC-3	0.165	81.8	11.4	3.9
PPC-4	0.177	80.6	8.5	3.4
PES-1	0.100	92.8	26.1	6.9
PES-2	0.085	93.9	26.9	8.9
PES-3	0.125	91.0	24.0	6.9
R-1	0.121	-	16.7	6.3
W-PES-1	0.018	98.7	53.9	9.7
F-PU-1	0.019	98.1	1.6	0.3
N	0.102	88.6	21.3	8.4

where:  $\rho$  is the fabric density in g cm<sup>-3</sup>; P is the fabric porosity in %; C is the compression in %; C<sub>L</sub> is percentage thickness loss in %.

The greatest compression percentage has polyester nonwoven fabric bonded thermally by hot air (W-PES-1; 53.9%), while the lowest compression percentage is noticeable for polyurethane foam (F-PU-1; 1.6%).

The greatest percentage thickness loss has polyester nonwoven fabric bonded by hot air (W-PES-1; 9.7%), while the lowest thickness loss is visible for polyurethane foam (F-PU-1; 0.3%). Within groups of nonwoven fabrics with different mass per unit area (PP, PPC, PES), effect of mass per unit area and/or thickness on thickness loss is not noticed.

Beside compression and thickness loss, the sample (W-PES-1) has greatest thickness reduction during compressing cycle (Table 3, Figure 6). It can be concluded that bonding by hot air gives voluminous structure of nonwoven fabric prone to compressibility and loss of thickness. The less compressible structure with lowest thickness loss after subjection to compression and decompression cycles had polyurethane foam.

## CONCLUSIONS

Nonwoven fabric thickness change obtained by compression and decompression cycle showed thickness decrease with increase of nonwoven fabric mass per unit area. The nonwoven fabric mass per unit area and thickness determine fabric porosity which influences on the freedom of fibre movements within nonwoven fabric. The nonwoven fabric of greater mass per unit area is less porous and movement of fibres within structure is less freely, resulting in smaller nonwoven fabric thickness change.

Comparing thickness change of calendared samples related to only needle punched nonwoven fabrics during compression and decompression cycle, less thickness change of calendared samples is visible. Result of calendaring process is more compact fabric structure related to only needle punched fabrics, where less thickness change due to compression and decompression cycles occur.

Comparing needle punched polypropylene fabrics and polyester nonwoven fabrics influence of the fibre type and parameters on compressibility is visible. Fibre parameters (density, fineness, length, cross-section, crimp, surface) influence on freedom of fibre movement within the fabric structure, thus influence on fabric compressibility. The nonwoven needle punched polyester fabrics density is greater while porosity is lower, comparing to polypropylene needle punched nonwoven fabrics, resulting greater thickness change of the compression and decompression cycles.

Greatest thickness change of compression and decompression cycle have polyester nonwoven fabric bonded by hot air, while lowest is noticed for polyurethane foam (F-PU-1). Bonding nonwoven fabric by hot air gives voluminous structure prone to compressibility and loss of thickness.

The compression percentage of needle punched and needle punched and calendared polypropylene as well needle punched polyester decrease with increase of mass per unit area. Needle punched polypropylene and polyester nonwoven fabrics of similar mass per unit area showed different compression percentage; respectively influence of the fibre type and parameters as well production parameters is noticeable.

The greatest compression percentage has polyester nonwoven fabric bonded thermally by hot air, while the lowest compression percentage is noticeable for polyurethane foam. Bonding by hot air gives voluminous structure of nonwoven fabric prone to compressibility and loss of thickness. The less compressible structure with lowest thickness loss after subjection to compression and decompression cycles had moulded polyurethane foam.

## REFERENCES

- [1] Midha VK, Alagirusamy R, Kothari VK. Studies on properties of hollow polyester needle-punched fabrics. *Indian Journal of Fibre & Textile Research*. 2004 Dec;29(4):391-399.

- [2] Kothari VK, Das A. An approach to the theory of compression of nonwoven fabric. Indian journal of fibre & Textile Research. 1996 Dec;21(4):235-243.
- [3] Backer S, Pettersonj DR: Some principles of Nonwoven Fabrics1. Textile Research Journal. 1960;30(9);704-711.
- [4] Debnath S, Madhusoothanan M. Compression behaviour of jute-polypropylene blended needle-punched nonwoven fabrics. Indian Journal of Fibre & Textile Research. Dec 2007;32(4):427-433.
- [5] Kothari VK, Das A. Compressional behaviour of layered needle-punched nonwoven geotextiles. Geotextiles and Geomembranes. 1993; 12 (2);179-191.
- [6] Kothari VK, Das A. Compressional behaviour of nonwoven geotextiles. Geotextiles and Geomembranes. 1992;11(3);235-253.
- [7] Kothari VK, Das A. Studies on compressional behaviour of nonwoven fabrics: Part II – Effect of rate of deformation, repeated compression-recovery cycle and pressure foot area. Indian Journal of Fiber and Textile Research. 1994; 19(1);17-21.
- [8] Vengsarkar SR. Stress strain characteristic of needle loom fabrics [dissertation]. Leeds: University of Leeds; 1966. 144 p.
- [9] Hearle JWS, Sultan MAI, Choudhari TN. A study of needled fabrics, Part-II: Effects of the needling process. Journal of Textile Institute. 1968; 59(2);103-116.
- [10] Hearle JWS, Purdy AT. On the nature of deformation of needled fabric, Fiber Science and Technology. 1972; 5(2);113-128.
- [11] Lunenschloss J, Gupta VP. Recent development in needling technology. International Textile Bulletin. 1981; 27(2);121-126.
- [12] Midha VK, Alagirusamy R, Kothari VK. Studies on properties of hollow polyester needle-punched fabrics. Indian Journal of Fiber and Textile Research. 2004; 29(4);391-399.
- [13] Kellie G. Advances in technical nonwovens. Cambridge: Woodhead Publishing Ltd; 2016. 342 p.
- [14] Debnath S, Madhusoothanan M. Studies on compression properties of polyester needle-punched nonwoven fabrics under dry and wet conditions. Journal of Industrial Textiles. 2012;41(4);292-308.

# MEDITERRANEAN WILD SILK - THE PROPERTIES OF COCOONS AND FIBERS

**Nikola JUGOV<sup>1</sup>, Ružica BRUNŠEK<sup>1\*</sup>**

<sup>1</sup>Faculty of Textile Technology, Department of Material, Fibers and Textile Testing, Prilaz baruna Filipovića 28a, Zagreb, Croatia, \*email: ruzica.brunsek@ttf.hr

---

## ABSTRACT

*The paper presents the investigation of the morphology and textile - technological properties of Mediterranean wild silk as potential textile material. Silk cocoon nests, as well as the fiber structure and silk cocoon shells of the mediterranean wild silkmoth, *Thaumetopoea pityocampa*, collected from Adriatic region were studied and compared with the cultivated raw silk fibers, *Bombyx mori*. Characterization was performed by following methods: scanning electron microscopy (SEM), energy-dispersive X-ray spectroscopy (SEM-EDS), Fourier Transform Infrared Spectroscopy (FTIR), thermogravimetric analysis (TGA), fineness, tenacity and elongation at break of fibers.*

## KEYWORDS

*Mediterranean wild silk, Pine processionary moth, *Thaumetopoea pityocampa* Schiff., conventional silk fibers, properties*

---

## INTRODUCTION

Systematic studies of fibres from unconventional sources, such as pine processionary caterpillar, open the possibility of exploiting new raw materials. The pine processionary produces a natural, protein type fiber of animal source. Although many insects produce silk, only the filament produced by the mulberry silk moth *Bombyx mori* is used by the commercial silk industry. The silk produced by other insects, mainly spiders, is used in a small number of other commercial applications, for example weapon and telescope cross hairs and other optical instruments [1]. Cultivated sericulture or rearing of the silkworms is done indoors in a controlled environment, where worms have a constant supply of food and care. The wild silk worms, such as *Thaumetopoea pityocampa* Schiff., feed and spin their cocoons in an open environment. Cultivated and wild silk differ not only in appearance, filament structure and self colour but also in their different amounts of sericin (gum), which is 20 - 30% in the case of cultivated silk and 8 - 15% in the case of wild silk [2]. Fiber is made out of two fibroin filaments wrapped with sericine, which is characteristic for silk fibers. This type of silk we called Mediterranean wild silk since the occurrence of producer species is reserved for Mediterranean area.

The pine processionary is major cause of defoliation of *Pinus* species in the Mediterranean area, in spite of efforts to reduce the population of this insect in repressive manners. Defoliation damage is extremely serious in young reforested areas where it may lead to death of trees, directly or because

of attack by bark beetles or other wood-boring insects. In mature forests, trees are rarely killed but significant losses occur in volume growth [3-5].

The defence mechanism of the pine processionary caterpillar is the release of tiny needle-like hairs, which inject poison into whatever the caterpillar feels threatened by. Therefore, the main attraction of these caterpillars to research is the urticating setae that they generate. In the third larval stage, the hairs begin to grow on the dorsal surface of two body segments. The urticating's hairs provide an effective protection against predators. The contact with pine processionary caterpillar can produce a strong inflammatory reaction on skin and mucous membranes. Other findings include hyperthermia, respiratory distress, cyanosis and tongue oedema, labial angioedema, conjunctivitis and severe tongue necrosis. As a moth, it has no means of causing a harm; it is only during the development as a caterpillar that it is need to be cautious. The moths seek out pine trees in the warm summer nights, lay clusters of eggs on the pine needles and so the process begins. There are five instars or growth stages, where they gorge on pine needles, shed their skins and double in size. This growth occurs during the winter when they disperse through the tree at night to feed, thereby avoiding predation, and collect in communal nests by day to increase their warmth and ability to digest [5-7].

There are only a few ways to control the pine processionary caterpillar:

- Mechanical control - mechanical removal of nests and destroying the caterpillars
- Chemical control - applying insecticides such as diflubenzuron, an insect growth regulator, which can be sprayed from aircrafts
- Biological control - by predators, parasites and viruses, which attack the moth at different stages of its life cycle

By applying any of these methods, complete eradication of one pest species is impossible. From an ecological point of view, they could be even harmful by disturbing the biological balance necessary for normal functioning of ecosystems.

Previous studies [8-11] were based only on the mass appearance of Mediterranean wild silk and attention was not focused on the fibre. Therefore, the aim of this paper is to investigate the morphology and textile - technological properties of Mediterranean wild silk and compared with the cultivated raw silk fibers, *Bombyx mori* by scanning electron microscopy (SEM), energy-dispersive X-ray spectroscopy (SEM-EDS), Fourier Transform Infrared Spectroscopy (FTIR), thermogravimetric analysis (TGA), fineness, tenacity and elongation at break of fibers.

## EXPERIMENTAL

### Material and Methods

Investigations were performed on Mediterranean wild silk taken from two silken nests (Figure 1) and compared with the cultivated raw silk fibers, *Bombyx mori*.



Figure 1. Fibres and cocoons of Mediterranean wild silk

The silken nests were mechanically separated from the pine tree in November 2017 and in March and April 2018. Characterization of Mediterranean wild and raw silk fibre was performed by following methods:

- **Scanning electron microscopy (SEM)**  
**Energy – dispersive X-ray spectroscopy (SEM-EDS)**

Fibres and cocoons interfaces and morphological features were studied by using scanning electron microscope (FE-SEM//Mira, Tescan) and equipped with the EDS detector for elemental analysis. SEM microscope was operated at 20 kV and various magnification levels due to the need to obtain a good SEM image. Prior to the SEM investigation samples were coated with Cr in order to increase their electrical conductivity. Results were obtained by arithmetic mean of the mass content of elements (wt%).

- **Fourier Transform Infrared Spectroscopy (FTIR)**

The surface chemistry of the fibres and cocoons was analysed by using an FTIR spectrometer (Spectrum 100 FT-IR; Perkin Elmer) equipped with an attenuated total reflection (ATR). Each spectrum was acquired with a resolution of 4 cm<sup>-1</sup> in 4 scans and the signal was measured in a range between 450 and 4,000 cm<sup>-1</sup>.

- **Thermogravimetric analysis (TGA)**

The thermal stability of the fibres and cocoons was evaluated by thermogravimetric (TG) analyses using PerkinElmer Pyris 1 TGA thermogravimetric analyser. All samples for TGA were heated from 50°C to 850°C at the heating rate 10°C/min in the air.

- **Fineness** (HRN EN ISO 1973:2008, Vibroscop 400), **tenacity and elongation at break** (HRN EN ISO 5079:2003 Vibrodyn 400)

The selected gauge length of the sample was 5 mm; testing speed was 30 mm/ min and tension 100 mg with 25 measurements of the individual fibres.

## RESULTS AND DISCUSSIONS

### Fibre surface analyzed with SEM microscopy

The morphology of the cultivated raw and Mediterranean wild silk fibres and cocoon shells are shown in Figure 2 at 2000x magnification. The Mediterranean wild silk fibres have a smooth surface with clearly visible two fibroin threads glued with sericin (Figure 3). The fibre has a specific heart-shaped oval cross-section (Figure 3). The fibres show a damage of sericin coat along surface and that can be attributed to aging of sericin. Furthermore, mineral components are observed in fibre surface. The longitudinal view of cultivated raw silk shows the raw silk fiber consisting of two filaments called fibroin bound by a soluble silk gum called sericin. Sericin gives MWS a rough touch and reduce shin.



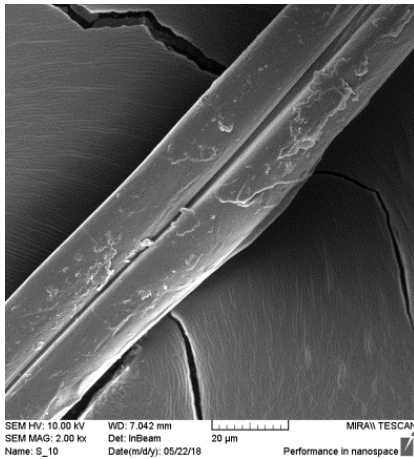

Cultivated raw silk fibre

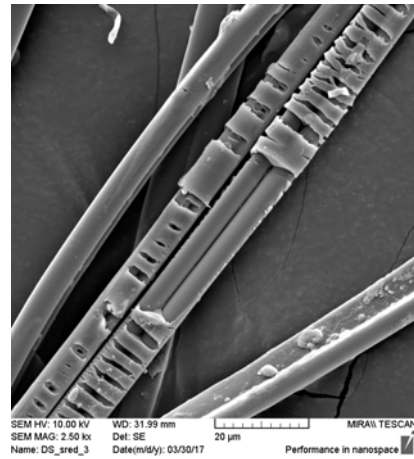

Mediterranean wild silk fibres

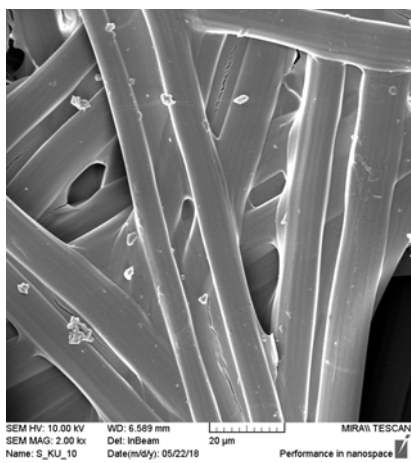

Outer surface of cultivated silk cocoon

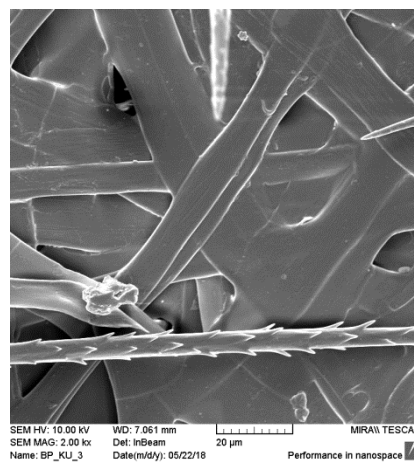

Outer surface of Mediterranean wild silk cocoon

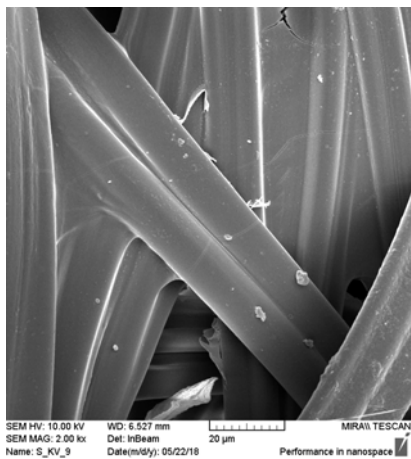

Inner surface of cultivated silk cocoon

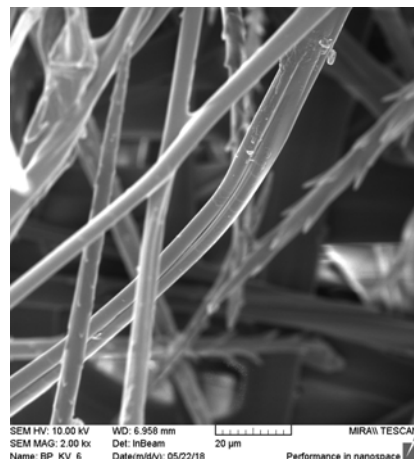

Inner surface of Mediterranean wild silk cocoon

Figure 2. SEM images of longitudinal view of the raw silk fibre, pine processionary fibre and silk cocoon shells at 2000x magnification

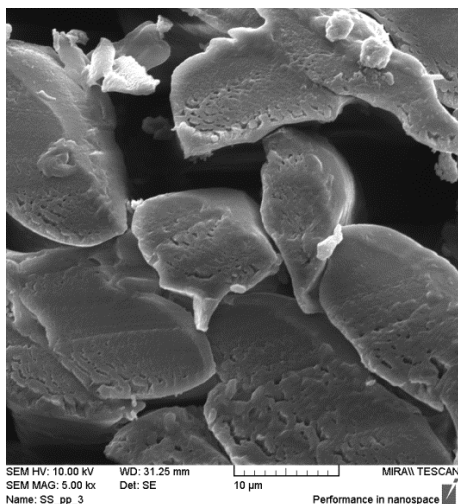

a) Cultivated raw silk fibers

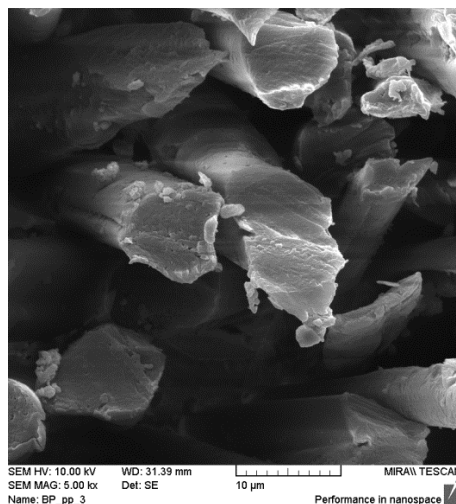

b) Mediterranean wild silk fibres

Figure 3. Cross-section of cultivated raw and Mediterranean wild silk fibres

Cocoon shells of Mediterranean wild silk are light brown colour with visible small strands on outer surface and contain organic material such as soil and particles of dust. The inner side of cocoon shell is smooth, glossy and containing pine caterpillar toxic setae. Cocoon is more elastic and difficult to break. Cocoon of Mediterranean wild silk is a medium porous cocoon.

#### Energy-dispersive X-ray spectroscopy (SEM-EDS)

In this method it should be emphasized that the results are taken with a low reliability since they are not measured on the surface of the whole sample but on the freely chosen part of the sample, indicating that the same sample, but elsewhere may be other chemical elements. Also, this is not a homogeneous sample and can not provide credible conclusions. The Table 1 provides the results of the SEM - EDS analysis of Mediterranean wild silk fibers at two different spots on fibers compared with results of cultivated raw silk fiber. It was found that the spectra of Mediterranean wild silk fiber are identified elements C, O, N, F, Cl, Ca, S, Na, K, Mg, Al, Si, P while SEM – EDS spectra of cultivated raw silk fiber are identified chemical elements C, O, Ca, S, P with higher mass content of elements than Mediterranean wild silk fibers.

Table 1. Elemental analyses results of Mediterranean wild silk and cultivated raw silk fibers

Identified Element	Mass content [wt.%]			
	Mediterranean wild silk fibre		Cultivated raw silk fiber	
	1. spot	2. spot	1. spot	2. spot
C	75.65936	58.0658	81.43833	75.89929
O	23.96765	22.58832	15.82256	21.72764
N	0	17.88615	0	0
F	0.23502	0.35295	0	0
Cl	0	0.12528	0	0
Ca	0.07256	0.04260	1.82724	1.66913
S	0.05335	0.06552	0.52723	0.22989
Na	0.01208	0.11644	0	0
K	0	0.07055	0	0
Mg	0	0.04619	81.43833	75.89929
Al	0	0.04618	15.82256	21.72764
Si	75.65936	58.0658	0	0
P	0	0	0	0

*Designation used in table: : wt.% - mass content of elements, C - carbon, O - oxygen, N - nitrogen, F - fluorine, Cl - chlorine, Ca - calcium, S - sulfur, Na - sodium, K - potassium, Mg - magnesium, Al- aluminium, P - phosphorus, Si – silicon.*

The SEM - EDS spectra of Mediterranean wild silk cocoon (Table 2) indicates redistribution of chemical elements on outer and inner side of the cocoon shell. On inner side of cocoon shell is identified chemical elements C, O, N, F, Cl, Ca, S, Na, K, Mg, Al and Si. On outer side of cocoon shell are identified most of the chemical elements from inner side of cocoon, without of element of phosphorus. The SEM - EDS spectra of cultivated raw silk cocoon indicates redistribution of chemical elements on outer and inner side of the cocoon shell. On inner side of cocoon shell is identified chemical elements C, O, N, F, Cl, Ca, S, Na, K, Mg, Al, Si and P. On outer side of cocoon shell are identified all of the chemical elements from inner side of cocoon.

Table 2. Elemental analyses results of mediterranean wild silk cocoon

Identified Element	Mass content [wt.%]			
	Outer surface of cocoon		Inner surface of cocoon	
	1. spot	2. spot	1. spot	2. spot
C	70.20371	66.92722	62.49308	56.31982
O	19.17486	23.01839	22.43421	23.99593
N	9.81454	9.33784	13.49065	18.87036
F	0.20804	0.19353	0	0
Cl	0.09109	0.04211	0.344205	0.22030
Ca	0.01651	0.02607	0.04904	0.02960
S	0.11633	0.10903	0.15752	0.08322
Na	0.03724	0.01640	0	0
K	0.24946	0.28295	1.00512	0.36230
Mg	0.06142	0.03027	0.02615	0.04938
Al	0.01292	0	0	0.05378
Si	0.01384	0.01615	0	0.01526
P	0	0	0	0

*Designation used in table: wt.% - mass content of elements, C - carbon, O - oxygen, N - nitrogen, F - fluorine, Cl - chlorine, Ca - calcium, S - sulfur, Na - sodium, K - potassium, Mg - magnesium, Al- aluminium, P - phosphorus, Si – silicon.*

By comparing these SEM – EDS spectra of mediterranean and cultivated silk cocoons (Table 3), it can be concluded that there are difference of wild and cultivated cocoon shells. The primary difference is in the mass content of elements (wt/ %): carbon, oxygen and nitrogen. Cocoon shell of mediterranean wild silk contains 63,9 % of carbon, 12,8 % of nitrogen and 22,1 % of oxygen, while cocoon shell od cultivated silk contains 57,4 % of carbon, 23,7 % of nitrogen and 16,2 % of oxygen.

Table 3. Elemental analyses results of cultivated silk cocoon

Identified Element	Mass content [wt.%]			
	Outer surface of cocoon		Inner surface of cocoon	
	1. spot	2. spot	1. spot	2. spot
C	63.07087	55.57463	56.61819	54.41380
O	14.24211	18.60731	13.91197	18.36442
N	19.89275	23.63049	26.39011	24.99115
F	0.41064	0.54863	0.46726	0.52723
Cl	0.17916	0.10715	0.45693	0.17698
Ca	0.45491	0.34745	0	0.28851
S	0.31339	0.21626	0.39308	0.21167
Na	0.25088	0.24311	0.76504	0.21982
K	0.25698	0.09928	0.33361	0.11853
Mg	0.26190	0.20720	0.24688	0.22009
Al	0.21822	0.14803	0.15482	0.16407
Si	0.21575	0.14004	0.15525	0.14832
P	0.23237	0.13034	0.10682	0.15535

Designation used in table: wt.% - mass content of elements, C - carbon, O - oxygen, N - nitrogen, F - fluorine, Cl - chlorine, Ca - calcium, S - sulfur, Na - sodium, K - potassium, Mg - magnesium, Al - aluminium, P - phosphorus, Si - silicon.

#### Fourier Transform Infrared Spectroscopy (FTIR)

The Mediterranean wild silk and cultivated raw silk fibres FTIR spectra are given on the Figure 4. The protein structure can be in the form of  $\beta$  - sheets,  $\beta$  - turns,  $\alpha$  - helix and unordered structure [12]. There are amorphous regions linking the crystalline regions [13]. The secondary structure of proteins, the amount and their orientation is different in the silk varieties [12]. In spectra of Mediterranean wild silk, regions presenting peaks of amid I, II, III and IV. Amid I region lies between 1700-1600  $\text{cm}^{-1}$  and presents conformation of the secondary structure. If amid I peak is between 1648-1644  $\text{cm}^{-1}$ , then the protein conformation is  $\alpha$ -helix, if peak is between 1648-1644  $\text{cm}^{-1}$ , then conformation is random coil [14, 15]. 1610-1640  $\text{cm}^{-1}$  peak represent the  $\beta$  -sheet [15]. In spectra of Mediterranean wild silk has been found that the peak at 1618  $\text{cm}^{-1}$  is due to weak intermolecular  $\beta$ -sheet [16-18]. The absorption band of 1500  $\text{cm}^{-1}$  corresponds to group amide II. Amid II bands are mainly from out-of-phase combination of CN stretching and the NH in-plane bending vibrations in protein backbone. Peak appearing in FTIR spectra in Mediterranean wild silk and cultivated silk around 1514  $\text{cm}^{-1}$  indicates the formation and crystallization of the  $\beta$ -form content. Peaks at 1386  $\text{cm}^{-1}$  and 1371  $\text{cm}^{-1}$  are characterized by bending of  $\text{CH}_2$  and they are found only in spectrum of Mediterranean wild silk. Amid III region are in range of 1300-1200  $\text{cm}^{-1}$ . Peak at 1233  $\text{cm}^{-1}$  is indicated conformation of  $\beta$  formed plate for amid III on spectra of Mediterranean and cultivated silk. In the area of 980 - 970

cm<sup>-1</sup>, peak at 975 cm<sup>-1</sup> is observed. It can be due to vibration of CH<sub>2</sub> bond and consisting of polyalanine glycine segment. The area of 965 to 950 cm<sup>-1</sup> is characteristic only in wild silks and indicates of polyalanine sequence on configuration of amid IV.

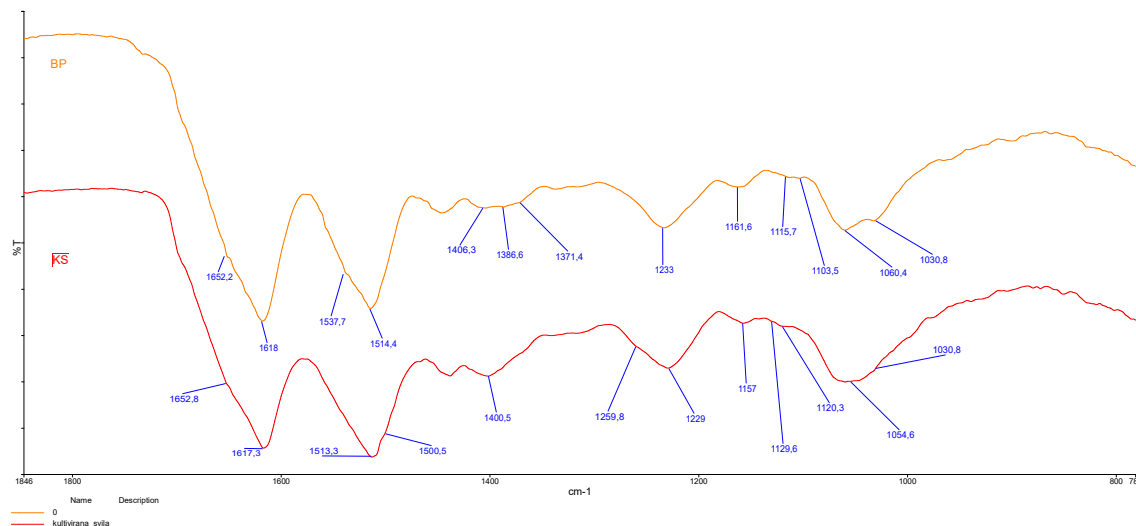

Figure 4. FTIR spectra of Mediterranean wild silk and cultivated raw silk fiber

### Thermogravimetric analysis (TGA)

Investigation results of thermogravimetric parameters (temperature, loss of mass) on fibers and cocoons of wild and cultivated raw silk are shown in Table 4.

Table 4. Investigation results of thermogravimetric parameters (temperature, loss of mass) on fibers and cocoons of wild and cultivated raw silk

Decomposition				
level (°C)/Mass loss (%)	Fibers		Cocoons	
T/°C	Mediterranean wild silk	Cultivated raw silk	Mediterranean wild silk	Cultivated raw silk
1°	50 - 201	50 - 208	50 - 182	50 - 202
Δy/[%]	6.491	4.335	6.362	5.556
2°	201 - 434	208 - 266	182 - 371	202 - 352
Δy/[%]	47.174	3.926	40.914	33.274
3°	434 - 614	266 - 345	371 - 508	352 - 522
Δy/[%]	37.596	26.858	18.747	23.327
4°	614 - 795	345 - 499	508 - 618	522 - 634
Δy/[%]	2.792	22.722	28.671	35.401
5°	/	499 - 643	618 - 794	/
Δy/[%]	/	38.538	1,682	/
Δy(process)/[%]	94.053	96.442	96.377	97.472

Designation used in table: T - temperature in degrees Celsius, 1° - the first level of decomposition, 2° - the second level of decomposition, 3° - the third level of decomposition, 4° - fourth level of decomposition, 5° - fifth degree of degradation, Δy/[%] - loss of mass in percentage, Δy (process)/ [%] - loss of mass throughout the degradation process.

By comparing the termogravimetrics results (TGA) of mediterranean wild silk and cultivated silk, it can be concluded that mediterranean wild silk fiber have better thermostability then cultivated raw silk because of gradient decreases of mass lose in curve. Termogravimetric curves of cultivated raw silk shows a drastic decrease in mass loss.

### Textile-technology properties of silk fibres

Along with the results of fineness, tenacity and elongation at break, Table 5. shows statistical indicators of variability - arithmetic mean value  $\bar{X}$ , standard deviation  $s$ , coefficient of variation CV and practical error limit  $p_{gg}$ . The results of fineness classified Mediterranean wild silk as a very fine fibre (0.74 dtex) compared to cultivated raw silk (4.42 dtex). By comparing the tenacity results it can be conclude that Mediterranean wild silk is more weak fibre (20.79 cN/tex) then cultivated silk (34.09 cN/tex). The results of elongation at break shows that the fibres of Mediterranean wild silk have a greater elongation (31.1%) more than cultivated raw silk fibres (26.23%), which is the characteristic of wild silks.

Table 5: Investigation results of textile-technology properties of the Mediterranean wild and cultivated silk fibre

<b>Fineness</b>	$\bar{X}$ [dtex]	$x_{min}$ [dtex]	$x_{max}$ [dtex]	CV [%]	$p_{gg}$ [%]
Cultivated raw silk	4.42	3.51	5.07	7.44	2.92
Mediterranean wild silk	0.74	0.52	1.04	18.81	7.37
<b>Tenacity</b>	$\bar{X}$ [cN/tex]	$x_{min}$ [cN/tex]	$x_{max}$ [cN/tex]	CV [%]	$p_{gg}$ [%]
Cultivated raw silk	34.09	22.37	45.78	17.99	7.05
Mediterranean wild silk	20.79	10.48	41.64	43.88	17.20
<b>Elongation at break</b>	$\bar{X}$ [%]	$x_{min}$ [%]	$x_{max}$ [%]	CV [%]	$p_{gg}$ [%]
Cultivated raw silk	26.23	11.60	40.00	33.59	13.17
Mediterranean wild silk	31.10	5.60	80.50	54.36	21.31
n			25		

Designation used in table: -  $\bar{X}$  arithmetic mean;  $x_{min}$  - min value;  $x_{max}$  - max value;  $s$  - standard deviation; CV - coefficient of variation;  $p_{gg}$  - practical error limit;  $n$  - number of measurements

### CONCLUSIONS

In this research of morphology and textile - technological properties of pine processionary fibre was identified that Mediterranean wild silk fibres are finer with much higher elongation at break compared to cultivated raw silk fibres. Its tenacity is lower than the tenacity of cultivated raw silk. The Mediterranean wild silk fibres have a smooth surface with visible furrows on the surface gumm.

Based on the thermogravimetric analysis it can be concluded that mediterranean wild silk fibers is in relation to the cultivated raw silk has better thermostability. The FTIR ATR analysis shows the mediterranean wild silk and cultivated raw silk fiber standard peaks related to protein fibres that originated from peptide bonds. Mediterranean wild silk consists of organized  $\beta$  – sheet crystal region and semi-crystal regions responsible for silk's elasticity compare to cultivated raw silk fibers.

Systematic studies of fibres from unconventional sources, such as silks produced by wild *Thaumetopea* insects brings new knowledge, that could be useful in further development of new textile eco materials. Silk fibres produced by wild *Thaumetopea* insects have properties suitable for commercial applications; however, further research is necessary to study the chemical and physical composition and potential applications for the wild silk. In addition, it is necessary to exam and find a safe way circumventing defence system of the pine processionary caterpillar.

#### **Acknowledgements**

The work has been supported by Croatian Science Foundation under the project 9967 Advanced textile materials by targeted surface modification.

#### **REFERENCES**

- [1] Franck, R. R.: Silk, Mohair, Cashmere and Other Luxury Fibres, Woodhead Publishing, ISBN 9781855735408, England, (2001)
- [2] Teli, M. D. & Rane, V. M.: Comparative Study of the Degumming of Mulberry, Muga, Tasar and Ericream Silk, *Fibres & Textiles in Eastern Europe*, **19** (2011) 2, pp. 10-14, ISSN 1230-3666
- [3] Fenk, L.; Vogel, B. & Horvath, H.: Dispersion of the bio-aerosol produced by the oak processionary moth, *Aerobiologia*, **23** (2007), pp. 79-87, ISSN 0393-5965
- [4] Shaw, J. T. B. & Smith, S. G.: Comparative studies of fibroins: III. The silk fibroin of the pine processionary moth (*Thaumetopoea pityocampa*) - An unusual  $\beta$ -protein, *Biochimica et Biophysica Acta* **46** (1961) 2, pp. 302-311, ISSN 0006-3002
- [5] Cheraghian, A.: A Guide for Diagnosis and Detection of Quarantine Pests, Bureau of Plant Pest Surveillance and Pest Risk Analysis, Available from <http://www.ppo.ir/Uploads/English/Articles/Bacterium%20phytoplasma/Bacterial-wilt-of-carnation-Burkholderia-caryophylli.pdf> Accessed: 2014-06-12
- [6] Androić, M.: Borov četnjak gnjezdar (*Cnethocampa pityocampa* Schiff.), *Šumarski list*, **13** (1957.), pp. 351-460, ISSN 0373-1332
- [7] Robson; R.M: Silk: Composition, Structure and Properties, In *Handbook of fibre chemistry*, Marcel Dekker Inc, ISBN 9780824725655, New York, (1985), pp. 415-456



- [8] R. Tiberi, M. Bracalini, F. Croci, G. T. Florenzano and T. Panzavolta: Effects of climate on pine processionary moth fecundity and on its egg parasitoids, *Ecology and Evolution* 2015; 5(22): 5372–5382
- [9] I. Kaszak, M. Planellas, B. Dworecka-Kaszak: Pine processionary caterpillar, *Thaumetopoea pityocampa* *Annals of Parasitology* 2015, 61(3), 159–163
- [10] D. Bonamonte, C. Foti, M. Vestita and G. Angelini: Skin Reactions to Pine Processionary Caterpillar *Thaumetopoea pityocampa* Schiff, *ScientificWorldJournal*. 2013; 2013: 867431.
- [11] L. Torres-Muros, J. A. Hódar and R. Zamora: Effect of habitat type and soil moisture on pupal stage of a Mediterranean forest pest (*Thaumetopoea pityocampa*), *Agricultural and Forest Entomology* (2016)
- [12] T. Lefèvre, M.-E. Rousseau, and M. Pézolet, "Protein Secondary Structure and Orientation in Silk as Revealed by Raman Spectromicroscopy," *Biophysical Journal*, vol. 92, pp. 2885- 2895, 2007.
- [13] F. Sehnal and M. Zůrovec, "Construction of silk fiber core in Lepidoptera," *Biomacromolecules*, vol. 5, pp. 666-674, 2004
- [14] P. Aramwit, S. Damrongsakkul, S. Kanokpanont, and T. Srichana, "Properties and antityrosinase activity of sericin from various extraction methods," *Biotechnology and Applied Biochemistry*, vol. 55, pp. 91-98, 2010.
- [15] P. W. Holloway and H. H. Mantsch, "Structure of cytochrome b5 in solution by Fouriertransform infrared spectroscopy," *Biochemistry*, vol. 28, pp. 931-935, 1989.
- [16] G.-T. Meng and C.-Y. Ma, "Fourier-transform infrared spectroscopic study of globulin from *Phaseolus angularis* (red bean)," *International Journal of Biological Macromolecules*, vol. 29, pp. 287-294, 2001.
- [17] O. N. Tretinnikov, "Influence of Casting Temperature on the near-surface structure and Wettability of Cast silk fibroin films," *Langmuir*, vol. 17, pp. 7406-7413, 2001.
- [18] P. Taddei and P. Monti, "Vibrational infrared conformational studies of model peptides representing the semicrystalline domains of *Bombyx mori* silk fibroin," *Biopolymers*, vol. 78, pp. 249-258, 2005

# THE TENSILE PROPERTIES OF YARNS TIED TO THE SCOUT KNOTS

**Antonija PETROV<sup>1</sup>, Ivana SALOPEK ČUBRIĆ<sup>1\*</sup>**

<sup>1</sup>University of Zagreb Faculty of Textile Technology, Prilaz baruna Filipovića 28a, 10000 Zagreb, Croatia, \*email: ivana.salopek@ttf.hr

---

## ABSTRACT

*The knowledge of knotting techniques on yarns with complex constructions is extremely important in a series of activities. One such activity is the scouting, towards which this paper is focused. In the introductory part of the paper is given a review of the types of yarns related to the formation of scout knots. The main objective of the paper is to examine the tensile properties of yarns that are tied to various scouting knots and furthermore, to determine which knot is more appropriate for the use regarding the values. On the basis of the measurements, it was found that the breaking elongation is the highest for the yarn tied to figure eight double knot. As far as the braking force is concerned, the highest values have yarns tied to granny knot. The importance of the examination is evident in the fact that knowledge about the tensile properties of the underlying samples is essential for the preservation of personal and general safety of the persons who use them.*

## KEYWORDS

*yarn, scout knot, tensile properties, breaking force*

---

## INTRODUCTION

Scouting aims to build and develop young people's confidence, sense of adventure and outdoor skills, as well as encouraging them to explore their beliefs, attitudes and creativity. It offers them the independence to put these skills into practice at camps and international trips. People have been tying knots on yarns for thousands of years. Today, despite the development of technology in every field, knots are still as necessary as were in the past. The ability to tie knots is a useful skill. Understanding the purpose of a particular type of knot and when it should be used is equally important. Using a wrong knot in single activity or situation can result in negative consequences. All knots have a certain purpose and it is just as important to understand what that purpose is, and when the knot is used, as having the ability to tie it appropriately [2].

The yarns and process of knotting have much greater meaning than people tend to think, and it goes far into the past. The first civilization that intensively used different knots on yarns with complex structure was the ancient Egyptians. Such structures were used, as they needed to move and transport huge rock stones used to build pyramids. Various skills of knotting were also developed by Chinese and have gradually expanded throughout the world.

The knotting techniques were mostly used by fishermen, but soon everyone who was involved in various outdoor activities understands the importance of knotting, whether it is used for hiking, camping, nature survival or seagoing. Various activities range from home activities, construction of bridges and ships, through fabric production etc. In order to tie different yarns to the certain scout knots, it is important to distinct different parts of yarn.

The important parts are shown in the Figure 1 and those are as follows:

- Working end – the end of the rope individual is using to tie a knot.
- Standing end – the end of the rope opposite to that being used to tie the knot.
- Standing part – any part between the two ends. It can be a part of the yarn already used in the knot.
- Loop – a loop made by turning the yarn back on itself and crossing the standing part.
- Bight – a loop made by turning the yarn back on itself without crossing the standing part.

A good knot must pass three tests:

- 1) it needs to be easy to tie,
- 2) it needs to stay tied for the whole duration of activity and
- 3) it needs to be easily untied [3].

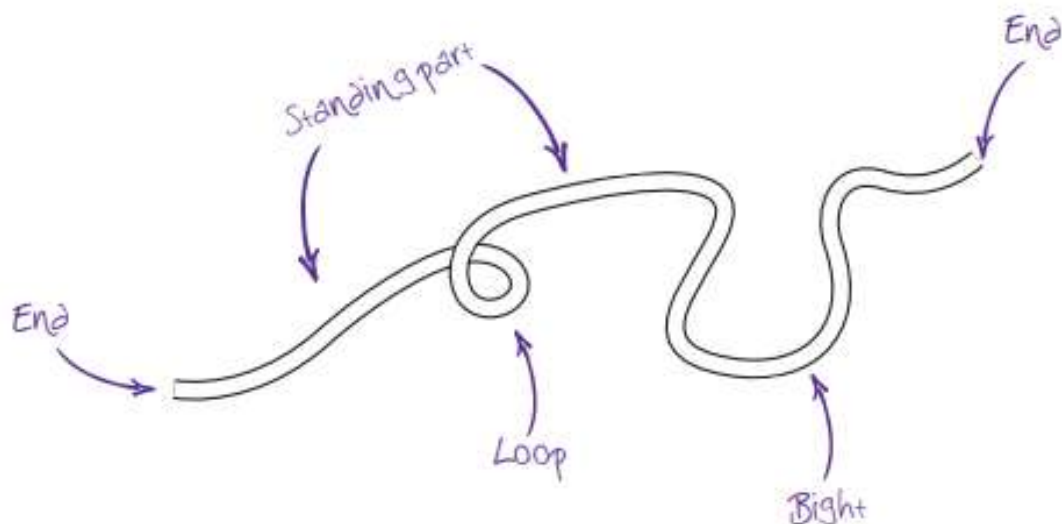

Figure 1. The main parts of yarn [3]

The names of many knots remind us of their origin. A number of names have changed depending on their new purpose, and many of them have more names. The list of knots is continuously updated and an example is given in the Figure 2.

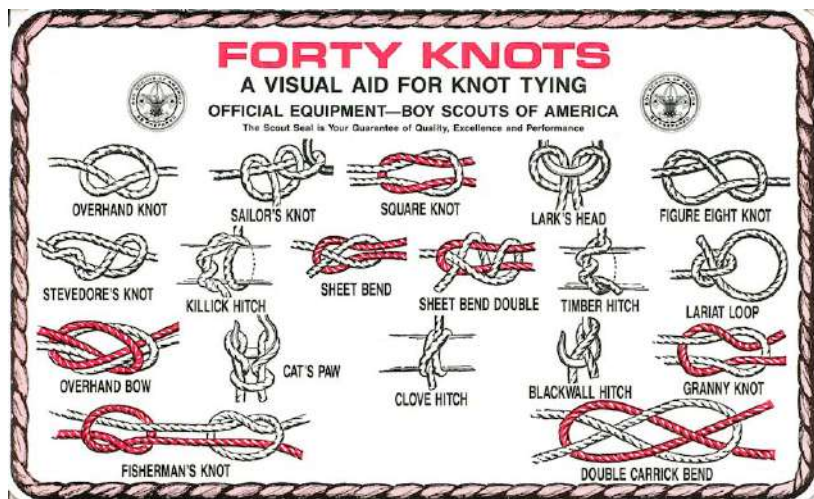

Figure 2. Types of scout knots [4]

## EXPERIMENTAL

In the experimental part of this paper, the tensile properties of yarns tied to different knots is investigated.

### Materials





For the investigation is used polyester stable yarn in count of 120 tex. According to its structure, the yarn is cable yarn, precisely 20 tex x 2 x 3. The total fineness of yarn is conditioned by the technical limitations of the measuring equipment used. The samples of yarn are tied to different knots, as shown in the Table 1.

Table 1. Details related to yarn samples

Number	Yarn ID	Type of knot
1	K 1	<b>Figure eight knot</b>
2	K 2	<b>Figure eight double knot</b>
3	K 3	<b>Square knot</b>
4	K 4	<b>Overhand knot</b>
5	K 5	<b>Granny knot</b>
6	K 6	<b>Double overhand knot</b>
7	K 7	<b>Bowline knot</b>
8	K 8	<b>Overhand bend knot</b>

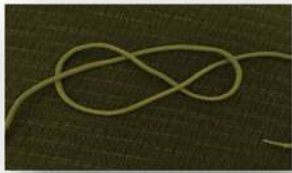
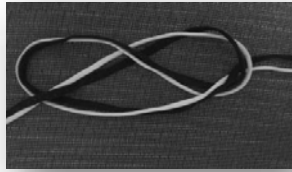
The detailed description of eight used knots are given in the Table 2.

Table 2. Description of used knots

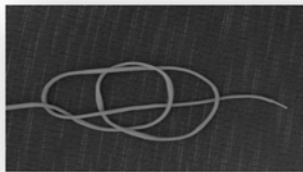
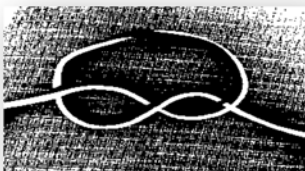
Type of knot	Image	Description
<b>Figure eight knot</b>		The figure-eight knot is a type of stopper knot. It is very important in both sailing and rock climbing as a method of stopping ropes from running out of retaining devices [5].
<b>Figure eight double knot</b>		The double figure eight knot is based on the simple figure eight knot. It is frequently used in climbing and caving as an easily untie-able knot that is capable of being attached to two bolts and equalised [6].
<b>Square knot</b>		Square Knot is quick and easy to tie; it is a good knot for securing non-critical items. This knot was used for centuries by sailors for reefing sails [7].
<b>Overhand knot</b>		The overhand knot is the simplest type of knot. It is primarily used to tie a knot at the end of a rope. The overhand knot is a stopper, especially when used alone, and it is very secure [8].
<b>Granny knot</b>		This knot is much like a square knot (also known as the reef knot). You can tell that you have a granny knot by the ends leaving perpendicular to the working line. Granny knot can be used to secure a rope or line around an
<b>Double overhand knot</b>		The double overhand knot is based on the overhand knot with one additional turn. It creates a reliable, moderately large, stopper knot [10].
<b>Bowline knot</b>		One of the most useful knots. The Bowline forms a secure loop that will not jam and is easy to tie and untie. This knot is reliable, strong and stable [11].
<b>Overhand bend knot</b>		The overhand bow knot is one of the most fundamental knots, and it forms the basis of many others. It is one of the easiest knots to tie. Stronger than overhand knot [12].

## Measurement of yarn properties

For all the yarns tied to 8 different knots are measured tensile properties. Tensile properties are measured on dynamometer Statimat M produced by Textechno, as described in ISO 2062. The measurement (20 samples for each type of knot) is carried out with pretension of  $0,5 \pm 0,1 \text{ cN tex}^{-1}$  and constant speed 200 mm/min [13]. Yarn samples are further, based on the outcomes of measurements, selected for the measurement in wet condition, what is also very important for materials used in scouting, as many of the activities are outdoor activities.

## RESULTS AND DISCUSSIONS

Within this chapter, results of measured breaking elongation and breaking force for yarns tied to 8 different knots are shown in the figures 3 and 4.

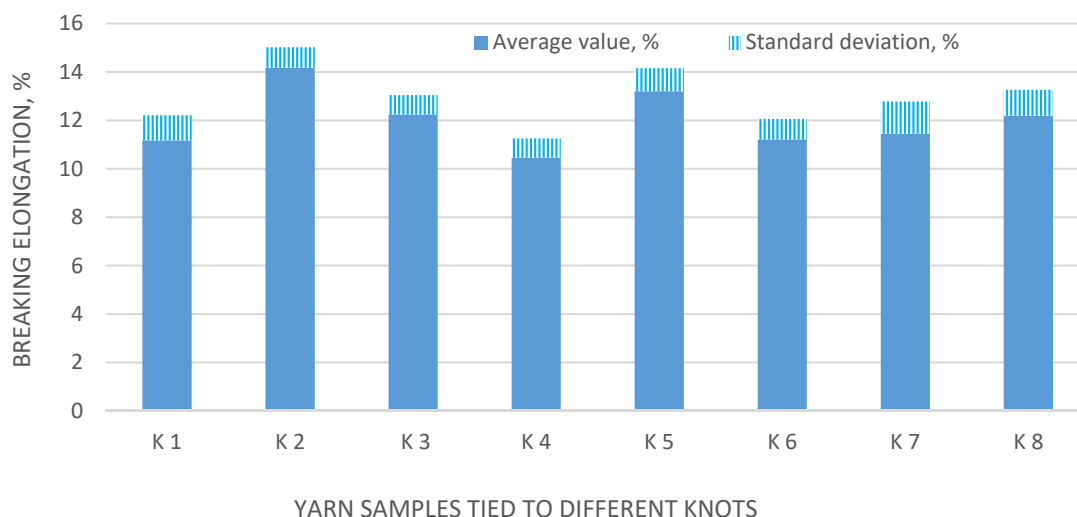

Figure 3. Breaking elongation of yarns

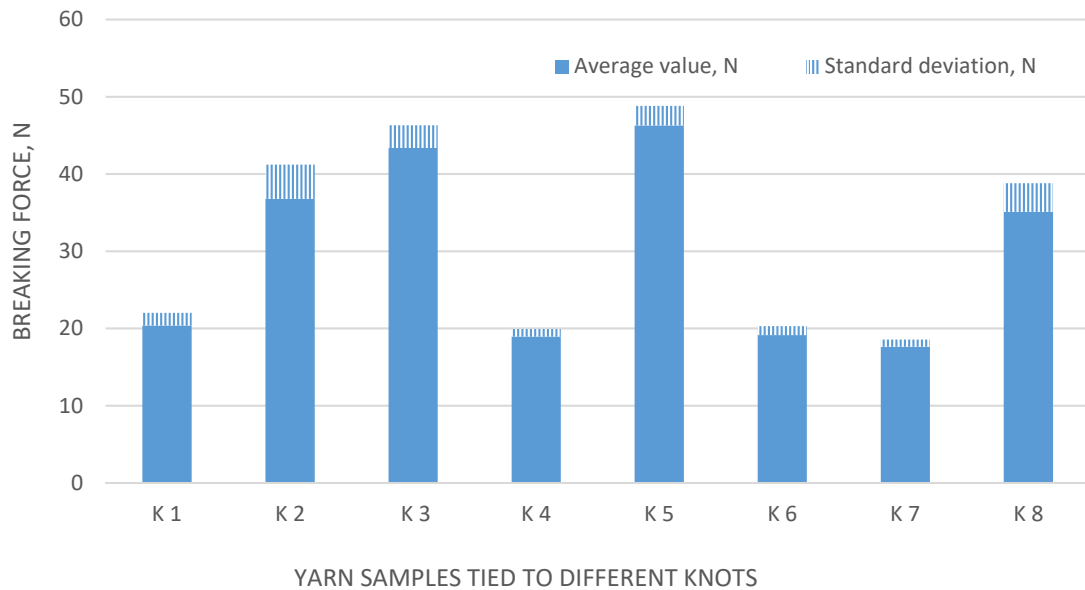

Figure 4. Breaking force of yarns

From the Figure 3, it could be seen that the values of breaking elongation are within the range 11-14%, being highest for the sample K2, i.e. the yarn tied to figure eight double knot. This is the knot that is tied in the form of figure eight, using two parallel yarns. Based on the practical application, it is known as the knot that is easy to untie. The lowest value of breaking elongation is measured for the sample tied to overhand knot, i.e. the simplest among investigated knots that is easily tied. As seen from the figure 3, the values of standard deviation of the observed property (i.e. breaking elongation) are within the range 0,8 to 1,3 and are highest for the yarn tied to bowline knot.

The results shown in the Figure 4 indicate significant differences in the values of breaking force that are within the range 19-46 N. The yarns tied to granny knot have highest breaking force among investigated samples (46 N). The structure of this knot has the ends leaving perpendicular to the working line. Considering the outcomes of the measurements, the use of such knot should be recommended for the cases when the larger force is applied to the yarn.

As opposite, the yarns tied to overhand and bowline knots have lowest values of breaking force, both under 20 N. The overhand knot is rather simple. In the literature [8], it is considered as very secure knot, but the results of measurements indicated that breaking force of yarn tied to this knot is rather low, what should be taken into consideration when using this type of knot. The same could be concluded for the bowline knot that is easy to tie and untie, but the values of breaking force are still low when compared to other investigated knots. The standard deviations of measured breaking forces are within the range 1-4 N, being highest for the yarn tied to figure eight double knot. Finally, due to the fact that results indicated higher differences in breaking force of yarns tied to different knots, these

outcomes should be carefully observed and taken into consideration when selecting optimal knot for a specific purpose.

In order to observe the changes of breaking force when yarn is wetted, or used in wet condition, 2 samples with highest and 2 samples with lowest breaking force are selected to be measured in wet condition. The results are shown in the Figure 5.

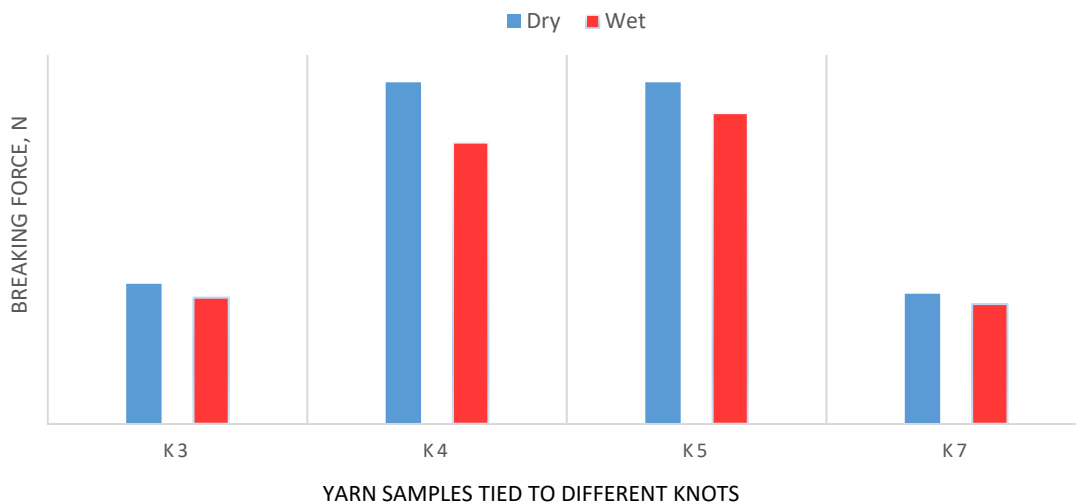

Figure 5. Comparison of breaking forces in dry and wet condition

Considering the presented results, it could be concluded that breaking force decreases for all observed samples up to 10%. Therefore, this is additional issue that has to be taken into account when selecting optimal knot.

## CONCLUSIONS

For scouts, it is important that the knots on yarns do not slide and that are firm enough to prevent interruptions and unwanted consequences. Also, the knots should not be released or discharged during use, and they must be easy and simple to carry out. It is very important that anyone who deals with knotting techniques, knows the yarn characteristics, and how to keep it in good condition.

On the basis of the examination of the tensile properties of yarns tied to various scouting knots, it was found that the breaking elongation was highest for the yarn tied to figure eight double knot, that is widely used in climbing and caving. Lowest breaking elongation has a yarn tied to overhand knot. As far as the breaking force is concerned, the highest values have yarns tied to granny knot and square.



Finally, the results of measurement indicated additional decrease of breaking force for all the observed samples up to 10%.

In this experiment, the influence of longer period of yarn wetness is not observed, but is another aspect that should be observed in future investigation, as well as the influence of salted water on the breaking force of selected yarns.

## REFERENCES

- [1] Petrov Antonija: Tenacity of yarns tied to scout knots, Diploma thesis, University of Zagreb Faculty of Textile Technology, 2017
- [2] <https://members.scouts.org.uk/factsheets/FS315082.pdf>
- [3] <https://members.scouts.org.uk/factsheets/FS315082.pdf>
- [4] <http://survivalknowhow.net/40-essential-boy-scout-knots/>
- [5] [https://en.wikipedia.org/wiki/Figure-eight\\_knot](https://en.wikipedia.org/wiki/Figure-eight_knot)
- [6] <https://www.animatedknots.com/fig8loopdouble/index.php>
- [7] [https://www.netknots.com/rope\\_knots/square-knot](https://www.netknots.com/rope_knots/square-knot)
- [8] <https://www.instructables.com/id/Overhand-Knot/>
- [9] <https://www.wikihow.com/Make-a-Granny-Knot>
- [10] <https://www.animatedknots.com/doubleoverhand/index.php>
- [11] [https://www.netknots.com/rope\\_knots/bowline](https://www.netknots.com/rope_knots/bowline)
- [12] [https://www.netknots.com/rope\\_knots/overhand-bend](https://www.netknots.com/rope_knots/overhand-bend)
- [13] ISO 2062:2009 Textiles – Yarns from packages – Determination of single-end breaking force and elongation at break using constant of extension (CRE) tester

# EXPLORING THE PROPERTIES OF YARNS FOR THE COLLECTION OF DESIGNER CHAIRS

Dora OJDENIĆ ĐEREK<sup>1</sup>, Ivana SALOPEK ČUBRIĆ<sup>1</sup>

<sup>1</sup>University of Zagreb Faculty of Textile Technology, Prilaz baruna Filipovića 28a, 10000 Zagreb, Croatia, \*email: ivana.salopek@ttf.hr

---

## ABSTRACT

*The chair as a style icon is a part of the seating furniture. Through the 20th century, the development of the chair is accelerated by the emergence of new technologies, using new methods and experimental materials (metal pipes, wire and later veneer plates, etc.). The adjustable ergonomically designed chair at this time becomes more versatile in its shape for each function. The experimental part of this paper consists of the selection of yarns, measurement of yarn properties important for the design of chairs, selection of optimal yarn and design of chair including the development of new product. For the purpose of chair design are selected different yarns from the market. The yarns are selected by textile designer, based on the appearance and without restrictions related to the yarn characteristics. The yarn properties, among which the fineness, breaking force, breaking elongation and abrasion, are investigated and the optimal yarn for the design of chair is selected. After that, the development of the designer's chair collection began with restoration of the useless metal construction of an old chair. Own concepts were created, tempting the limits of creativity. In the next step, the uneven surface of applied fancy yarn increased the attractiveness of chair. In the paper are described all the steps in design of "RE chair", as well as its particularities i.e. the fact that the "RE chair" moves the boundaries in aesthetic appearance with the possibility of repeating the design and becoming an individual experiment.*

## KEYWORDS

*yarn, design, chair, collection, tensile properties*

---

## INTRODUCTION

The chair as a style icon is a part of the seating furniture. Some of them are simple and sophisticated, others are non-conventional, some are luxurious, some are made of the most common material - wood, but also have a timeless connection - advanced design [1]. The earliest record of chairs appeared in ancient Egyptian tomb paintings. The difference in design of chairs between then and now are clear, but there are still some things that haven't changed. Before the 12th century, most commonly used seats were primarily three-legged stools or benches. They were primitive, crudely made, and purely functional. At that time, chairs were a sign of wealth. But even in that period some of the more advanced civilizations (such as Egypt, Roman Empire, the Greeks) had the chairs of high-profile features and those represent the foundation of today's chairs. Gothic style influenced furniture, which was often carved. In that period, high-backed and very straight cathedral chairs were typical. During the Renaissance, chairs became more refined, lighter, more comfortable and more decorative. Looks became as important as function. After the introduction of luxurious ornamentation, veneers,

rich fabrics, exotic wood, stones, gold and silver, chair is seen not just like a piece of furniture, but also the artefact that displays the status of wealth.

Table 1 History of the chair [2]

Period	Description	Image	Period	Description	Image
3000-2000BC	Ancient Egyptian Furniture		2000-300BC	Ancient Greek Furniture	
500-1450AD	Medieval Furniture		1350-1550AD	Renaissance Furniture	
1567-1625AD	Jacobean Furniture		1500-1754AD	Colonial Furniture	
1725-1775AD	Rococo Furniture		1800-1900AD	Revival Furniture	
1890-1914AD	Art Nouveau Furniture		1919-1933AD	Bauhaus Furniture	
1925-1940AD	Art Deco Furniture		Present	Contemporary Furniture	

The 18<sup>th</sup> century period took that richness and formality even further. Monarchs ushered in Rococo forms, curved lines, floral decorations and even more ornamentation. Instead of owning just one kind of chair, the middle and upper classes now had several kinds of seating: stools for perching, dining chairs, side chairs, armchairs, a low bench by the fire [3].

Through the 20th century, the development of the chair is accelerated by the emergence of new technologies, using new methods and experimental materials (metal pipes, wire and later veneer plates). New professions emerge like tappers that come as new chair designers using a variety of aesthetic ideas, types, shapes and patterns of materials so the rugs had different solutions for use in furniture. The adjustable ergonomically designed chair at this time becomes more versatile in its shape for each function [4].

### **Recent trends in chair design**

Among recent successful chair designs the diamond chair, spaghetti chair and Acapulco chair may be pointed out.

#### a) Diamond chair

Harry Bertoia was an artist, sculptor and designer of furniture born in Italy in 1915 in a small village of San Lorenzo. Since early youth, Harry Bertoia had a unique talent for jewellery and wedding dresses design. His passion for jewellery inspired him to create a "Diamond" chair. Bertoia imagined the chair as a diamond, and designed it in that shape. To give it the purity and transparency of the diamond, he made a chair of metal rods, because he liked the idea of air passing through the chair. The shape of the diamond and the construction made of metal rods make it one of the most recognizable designs of the middle of the 20th century. Its popularity is not difficult to understand, it is beautiful, comfortable, suitable in every space [5].

#### b) Spaghetti chair

In the retro style, the Spaghetti chair, with its history dating back to tropical Mexico, thanks to its round, harmonized shape and polyethylene ropes, provides excellent seating comfort. Because of its modern and simple appearance, the Spaghetti chair can be easily redesigned. Cushions, blankets or sheep wool can be used in the redecorating chair, whether it is spring, autumn or winter. The spaghetti chair is lightweight with a weight of 5.3 kg and can be easily moved from the outside to the indoor area. Its advantage is that in small spaces this retro item with its graceful dimensions occupies very little space [6].

#### c) Acapulco chair

The timeless concept, non-imposing elegance and maximum comfort are the basic features of the Acapulco lounge chair, which is among the greatest 20th century design icons. These simple and elegant chairs made of flexible vinyl bands create a comfortable base on a metallic pear shape construction and perfectly reflect Mexican summer resorts and vibrant colours that are typical of the recognizable Acapulco design [7].

Based on the presented trends in chair design, the aim of the investigation presented in this paper is to select the optimal yarn for the use in chair design and to develop a designer chair.

## EXPERIMENTAL

The experimental part of this paper consists of the selection of yarns, measurement of yarn properties important for the defined final use (i.e. in the furniture design), selection of optimal yarn and design of chair including the development of new product.

### Selection of yarns

For the purpose of chair design are selected five different yarns from the market. The yarns are selected by textile designer. The selection is based on the appearance only and without any restrictions related to the yarn characteristics. The details related to the structure and raw material as well as the yarn designation are given in the Table 2.

Table 2 Details related to selected yarns

Number	Yarn ID	Structure	Raw material
1	Y A	cable yarn	cotton + viscose
2	Y B	chenille fancy yarn	polyamide
3	Y C	fancy yarn with metal component	viscose + polyester
4	Y D	cable yarn	cotton + viscose
5	Y E	ply yarn	viscose

### Measurement of yarn properties and selection of optimal yarn

For all 5 selected yarns are measured fineness and tensile properties (breaking force and elongation). The fineness is determined by the use of skein method, as described in ISO 2060 [8]. Tensile properties of produced yarns are measured on dynamometer Statimat M produced by Textechno, as described in ISO 2062 [9]. The abrasion of yarns is carried out using the abrasion device equipped with sandpaper with granulation 40. The DINO-Lite microscope is used to take images of yarns before and after abrasion. In the results chapter are show images before and after 200 cycles of abrasion, as at the minor number of cycles, the changes in yarn appearance were not so prominent. The images are taken under magnification of 50x and used to observe the changes in the structure due to abrasion process. Based on the results of yarn measurements, among the selected five yarns, the optimal yarn is defined and used for the design of chair.

### Preparation of chair base for the development of a new product

The process of chair design started from the completely damaged frame of a chair that has been left for years in the Cetina River near Omis, Croatia. The process of restauration included the mechanical cleaning with solvent (polar solvents - water, acetone, alcohol), structural and surface

replacement of missing parts and final colouring and finishing of the whole structure. The base of chair is finally formed by interlacing the polyester rope [10]. The phases of preparation are shown in the Figure 1.

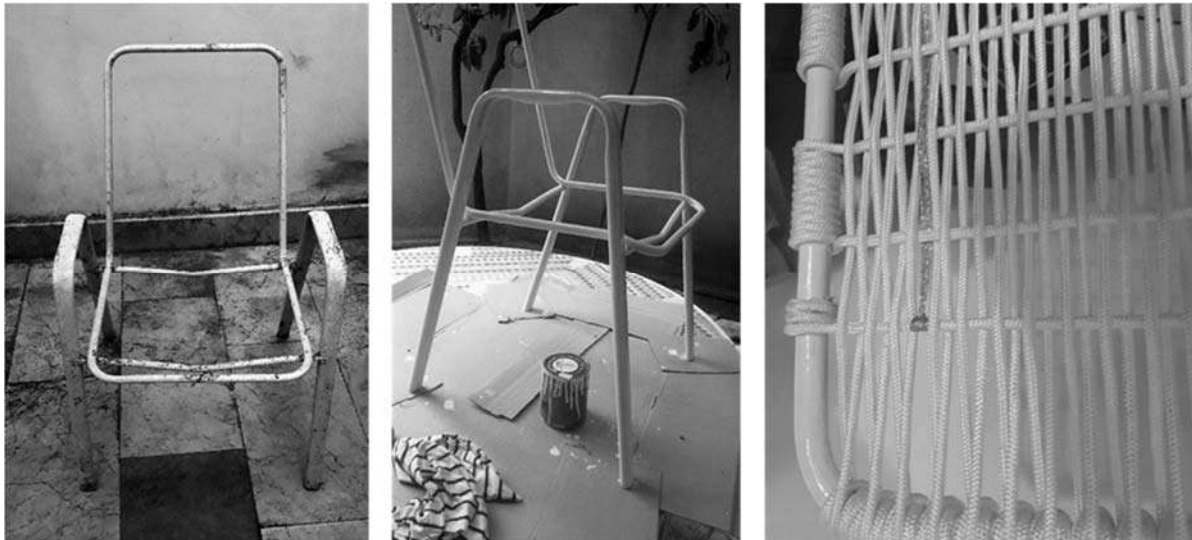

Figure 1. Phases in the preparation of the chair base

## RESULTS AND DISCUSSIONS

Within this chapter, results are presented and discussed.

### Results of yarn measurements and selection of optimal yarn

The results of yarn measurements that refer to the yarn fineness, breaking elongation and breaking force are given in Figures 2 and 3. The images of yarns taken before and after abrasion are shown in the Table 3. As can be seen from the Figure 2, the fineness of selected yarns is in the range 150-410 tex.

According to the presented values of breaking force, highest values are characteristic of samples Y A, than YD and Y C. Higher values of breaking force are desirable for the use in chair design, so the samples Y B and Y E should not be selected for the purpose of chair design. Regarding the breaking elongation, very high and very low values are also not recommended for this purpose, so among selected yarns, the advantage should be given to the yarns Y C and Y E.

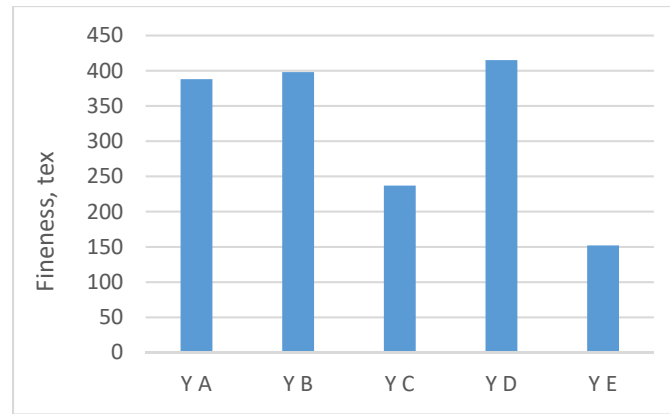
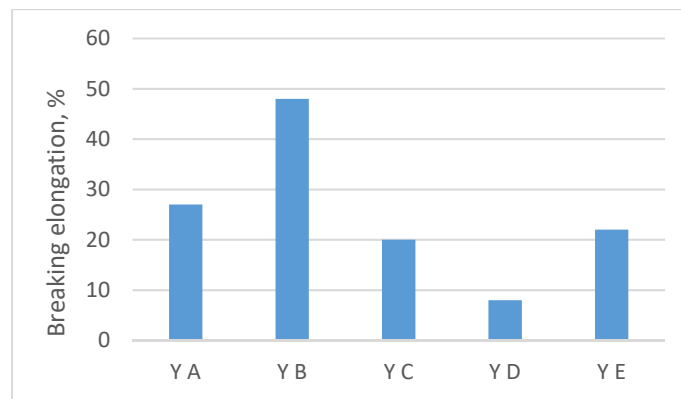
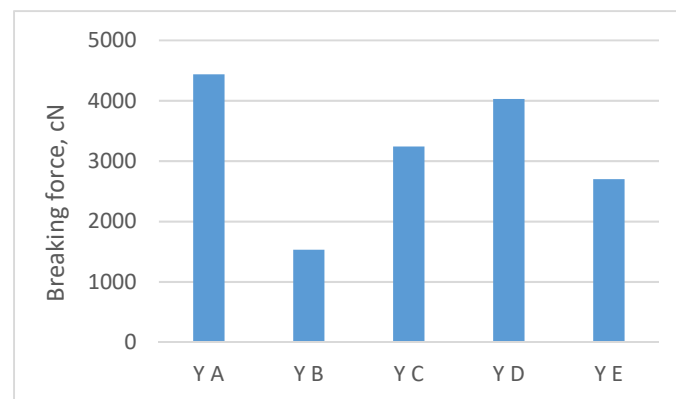

Figure 2. Fineness of selected yarns



a.











b.

Figure 3. Tensile properties of selected yarns: a. breaking elongation and b. breaking force

The images of yarns taken after abrasion indicate significant changes of structure for yarns Y A, Y D and Y E, where the number of protruding yarns is high and the whole structure is open, what also affected the changes in yarn diameter. As can be seen from the Table 3, the abrasion process did not affect changes in the structure of yarns assigned as Y B and Y C. Taking into account the discussed values of breaking force, breaking elongation as well as the appearance of yarns after 200 cycles of

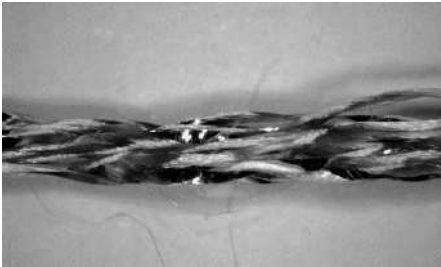
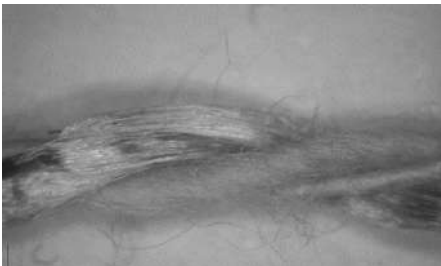
abrasion, the yarn Y C is defined as more appropriate for the use among investigated yarns and therefore selected for chair design.

Table 3. Images of yarns before and after abrasion [10]

	Before abrasion	After abrasion
Y A		
Y B		
Y C		
Y D		
Y E		

### Designed chair and developed product

In the next phase, the yarn Y C is used to wrap the formed base of chair and to complete the process of chair design (Fig. 4). The possibility to wrap the yarn in different ways and directions allows the development of the whole designer collection of chairs. The developed chair is named „RE chair”,



as it enables the use of yarns with the same characteristics, but in different colours that can be replaced after certain period and thus be harmonized with the interior design. The following step in development of this product was the introduction of wooden chair models as a supplement to the „RE chair”, what is one of the main advantage of the collection. As a main part of the "RE chair" collection, a chair model is used to simulate the look of the chair before the design process. In order to better match the "RE chairs" collections with the latest trends, moods and different styles, the yarns can be reinterpreted as needed, independently to design different living spaces. At the same time, the customers also independently design their own chair and thus encourage their own creativity. Figure 5 shows possible options.



Figure 4. A finished chair wrapped in yarn Y C

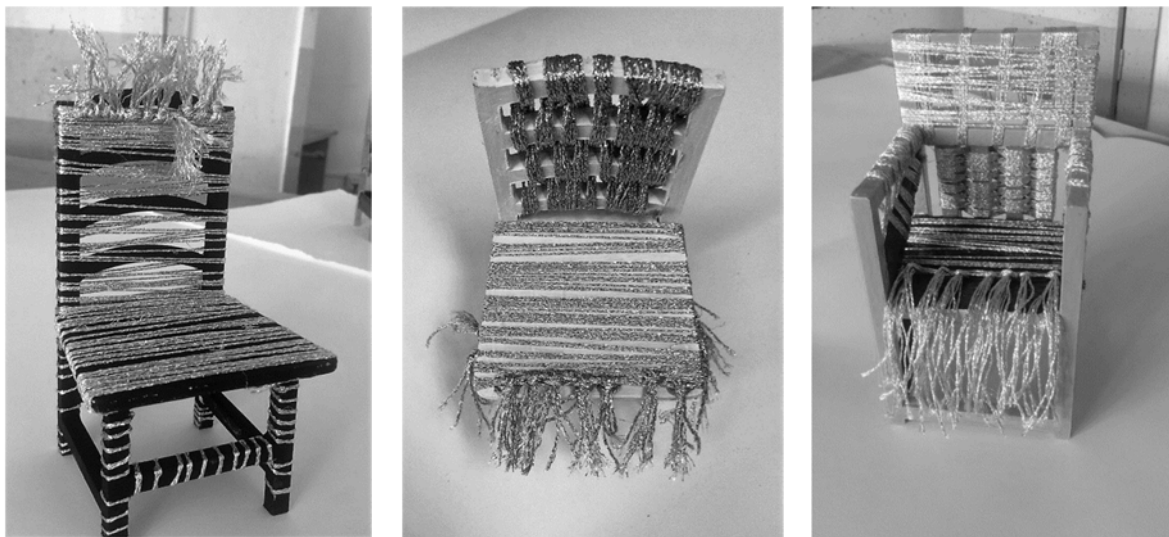

Figure 5 Chair models wrapped in effect yarn

## CONCLUSION

The purpose of this work was to examine the characteristics of different yarns and to choose the optimal yarn for the use in chair design, based on the measurement results. After that, the development of the designer's chair collection began. From the unused furniture pieces, own concepts were created, tempting the limits of creativity. The uneven surface of the flat product made of fancy yarn increased the attractiveness of appearance, Every "RE chair" chair is special because in one of its domains, it moves the boundaries - in aesthetic appearance with the possibility of repeating the design and thus becomes an individual experiment.

## REFERENCES

- [1] Vukorepa A. Nastali su prije sto godina, a još su tu. Furniture Journal [Internet]. 2014 [cited 2018 Oct 15]. Available from: <https://living.vecernji.hr/interijeri/nastali-su-prije-sto-godina-a-jos-su-tu-946695>
- [2] Jean-Marc Fray. History of the chair, History series an evolution in seating. Furniture Journal [Internet]. 2018 [cited 2018 Oct 14]. Available from: <https://jeanmarcfray.com/history-of-the-chair/>
- [3] Pourny C, Renzi J, Stewart M. The Furniture Bible: Everything You Need To Know To Identify, Restore Care For Furniture. New York: Artisan; 2014. 304 p.
- [4] Gurr K, Straker L, Moore P. History of seating: A History of Seating in the Western World, Furniture Journal [Internet]. 1998 [cited 2018 Oct 14]. Available from: <http://www.exmoorantiques.co.uk/History%20of%20Seating.htm>
- [5] Dom Info. Kultni dizajn: Stolica Dijamant, prostor prolazi kroz nju. Furniture Journal [Internet]. 2016 [cited 2018 Oct 15]. Available from: <https://www.dominfo.ba/kultni-dizajn-stolica-dijamant-prostor-prolazi-kroz-nju/>
- [6] The Kare blog. The Spaghetti Chair for indoors and outdoors. Furniture Journal [Internet]. 2017 [cited 2018 Oct 15]. Available from: <https://blog.kare.de/en/the-spaghetti-chair/>
- [7] Maucieri D. Vinilne trake opet su 'in': stolica Acapulco proživljava novu mladost. Furniture Journal [Internet]. 2015 [cited 2018 Oct 15]; Available from: <https://slobodnadalmacija.hr/stil/kvadrat-po-mom/clanak/id/272398/vinilne-trake-opet-su-in-stolica-acapulco-prozivljava-novu-mladost>
- [8] ISO 2060:1994 Textiles -- Yarn from packages -- Determination of linear density (mass per unit length) by the skein method
- [9] ISO 2062:2009 Textiles -- Yarns from packages -- Determination of single-end breaking force and elongation at break using constant rate of extension (CRE) tester
- [10] Ojdenić D. Projektiranje pređa za kolekciju stolica [diploma thesis]. Zagreb: University of Zagreb Faculty of Textile Technology; 2018. 69 p.

# MULTIPLE FACES OF KNITTING IN PAST AND MODERN TIMES

**Alenka PAVKO-ČUDEN<sup>1\*</sup>**

<sup>1</sup>University of Ljubljana, Faculty of Natural Sciences and Engineering, Department of Textiles, Graphic Arts and Design, Aškerčeva 12, 1000 Ljubljana, Slovenia, \*email: alenka.cuden@ntf.uni-lj.si

---

## **ABSTRACT**

*Knitting is a traditional textile technique with great significance both in past and modern times. Similar to other textile techniques, knitting has developed from hand manufacturing into an industrial sector with wide range of applications comprising the production of knitted fabrics, knitwear, hosiery, fashion accessories, interior knits, technical knits, etc. At the same time, contemporary knitting became a hobby as well as arts-and-crafts activity, extending to various areas of work and leisure. While industrial knitting involves more and more non-clothing areas and merges with other textile techniques, historical and traditional ethnic knitting patterns keep inspiring designers' collections and also other industrial products. The paper reviews and comments many forms and positive effects of past and contemporary knitting. It analyses the grounds of their development as well as their specifics compared to other textile techniques and industrial production in general. It shows the specialities and trends in industrial knitting development and the change of the hand knitting concept. It also indicates the paradox of the popularity of modern hand-knitting and discusses its importance in the context of sustainability and wellbeing.*

## **KEYWORDS**

*knitting, machine knitting, hand knitting, technological development*

---

## **INTRODUCTION**

Knitting is a traditional textile technique with great significance both in past and modern times. For centuries it has been a part of everyday life as well as an important contributor to the society and economy. Similar to other textile techniques, knitting has developed into a diversified industrial sector, comprising the production of knitted fabrics, knitwear, hosiery and fashion accessories for clothing as well as for non-clothing purposes like interior knits, sportswear and other sport equipment, and above all so-called „agrotech“, „meditech“, „geotech“, „buildtech“, „mobiltech“, „indutech“, „packtech“ and „protech“ [1] knits.

At the same time, contemporary knitting has (once again) become a hobby as well as means of artistic expression and arts-and-crafts activity, extending to various areas of work and leisure. Historical and traditional ethnic knitting patterns keep inspiring designers' collections and also other industrial products [2].

The paper reviews and comments many forms and positive effects of past and contemporary knitting. It analyses the grounds of their development as well as their specifics compared to other textile

techniques and industrial production in general. It shows the specialities and trends in industrial knitting development and the change of the hand knitting concept. It also indicates the paradox of the popularity of modern hand-knitting and discusses its importance in the context of sustainability and wellbeing.

### **KNITTING: DIVERSIFIED, FAST-DEVELOPING, INNOVATIVE AND ADAPTABLE TECHNOLOGY**

Knitting industry that arose in the two centuries following the invention of the weft knitting machine in 1589 took on the forms and organization of contemporary crafts, gradually evolving into an organized domestic system of manufacture. Its transition into the factory system of production took place well after the Industrial Revolution that had transformed most other branches of textile manufacture; in the 1870 the domestic system was still predominant and traces of it persisted as late as 1920 [3]. Although the rural knitting continued in some poorer parts of the country, over the 18th century hand-knitting mainly became the domain of wealthier ladies who had the time to devote to developing the skill. By the mid-19th century, so-called „fancy" knitting was flourishing as an elegant drawing room occupation. Decorative objects such as net purses or pincushions were made by well-to-do women to demonstrate their taste and skill [4].

In England, where the first knitting machine was invented, the factories that displaced the domestic system were established only late in the 19th century. They were for the most part the small family businesses engaged in the production of hosiery and underwear. Significant amounts of weft knitted outerwear, pullovers, and cardigans, did not appear until near the turn of the century, and knitted fabrics awaited the introduction of man-made fibres before they grew to constitute the forth major sector of the industry in England [3].

Nowdays, when we are talking about knitted fabrics and knitwear, we usually have a large-scale industrial production in mind. But as previously noted, there has always existed a bi-polar knitting manufacture. On one hand, there is knitting craft and on the other, knitting and hosiery industry. Even if the change from the craft to the industrial level seemed logical, the development in knitting was not so simple and smooth as it might have been expected, mostly because of the limited patterning possibilities of early knitting machines. Even in the time of Industrial Revolution, the finest knitted garments with elaborated structures and designs were manufactured by hand. Particularly popular were the kind of hand-knitted and beaded lace items that couldn't be copied by knitting machines. Victoria&Albert Museum holds an extraordinary baby's gown (Figure 1) that won third prize in the Great Exhibition's hand-knitting section in Great Britain in 1851.

Knitted on extremely fine needles, the gown's patterns of open stitches are similar to those of the knitted Shetland lace shawls popular in the 1840s. It was said that this gown was made with over

a million stitches and 6,300 yards of cotton and that its maker, Sarah Ann Cunliffe, worked seven hours a day for five months to complete it [4].



Figure 1. Baby's dress, manufactured by Sarah Ann Cunliffe in 1851, Britain. (Museum no. T.45-1964, Victoria and Albert Museum, London) [4]

Like other textile and non-textile technologies, machine knitting evolved from a hand technique and set the keystone principle of the weft knitting process. Contemporary weft knitting still consists of two basic areas, hand manufacture and industrial production. With the development scattered into flat and circular knitting; hosiery, knitwear and non-clothing sectors; panel, tubular, fully-fashioned, integral and seamless knitting; it proves that one basic starting point allows for development in many, very different directions.

Warp knitting, in contrast to weft knitting, exists only at an industrial level. Warp and weft knitting, although similar when their loop construction is viewed from the face side, are quite different in their mechanical behaviour and properties. The only common denominator is the loop, all other aspects are different: yarn feeding into the knitting zone, knitting elements, loop formation, yarn tension, fabric construction, fabric properties and end uses. Furthermore, the warp knitting is more and more identified with technical and other non-apparel fabrics [5].

Warp knitting is a significant and ever growing industry; it is also the youngest industry if compared with weaving or even with weft knitting. It took almost 200 years until Crane of Nottingham applied warp yarn guides to Lee's knitting frame, an invention that gave birth to warp knitting. Even though most of warp knitting production is based of continuous filament yarns, the range of products is extremely wide and ever expanding. Lingery, lightwear, shirting, sheeting, elastic fabrics for

foundation garments and swimwear, domestic and automotive upholstery, curtains, drapes, lace, a large section of geotextiles and industrial textiles are all within the range of products knitted today on warp knitting machines [5].

Although warp knitting was initially a continuous fabric manufacturing process, it was later inspired by weft knitting and has eventually evolved into seamless option. We could say that the predecessor of the warp seamless knitwear was Miyake's famous A-POC, an acronym for „A Piece of Cloth” concept (Figure 2). It is a manufacturing method that uses computer technology to create clothing from a single piece of yarn in a single process. Its development began in 1997. After 2007, the collection introduced design solutions under the subtext of „A-POC INSIDE” and has continued to refine its vision for making clothing [6]. A-POC is an innovative outfitting system that produces self-tailored clothing through mass productions. An industrial machine is preprogrammed to fabricate an enormous, continuous tube of fabric. A repeating pattern of seams is integrated into the tube, creating a patchwork of shapes whose outlines begin to suggest dresses, shirts, socks, gloves, and hats. The customer can cut along the seams without destroying the tubular structure of each individual item. The result is a puzzle of monochromatic articles of clothing that leaves behind virtually no wasted material [7]. Each item is designed to be slightly oversized when cut from the roll, allowing users to further customize their garments with scissors – sleeve length, bias, and neckline are just a few of the possibilities. By making the wearer the ultimate designer of the outfit, Miyake and Fujiwara's rapid, efficient, and infinitely customizable system pushes conventional textile technology and creates everyday clothing that transcends ephemeral fashion trends [8].

So, at the turn of the millennium, Miyake and Fujiwara paved the way to the sustainable seamless knitting philosophy, together with Santoni which first presented the seamless underwear knitting machines derived from hosiery machines at ITMA 1999 in Paris [9], and Shima Seiki which introduced the first wholegarment knitting concept derived from glove-knitting technology at ITMA 1995 in Milan. Therefore, seamless machine-knitting of outer garments appeared six centuries after Master Bertram of Minden [10] had painted his Visit of the Angel representing Madona knitting a seamless garment.

Warp knitting, on the other hand, significantly affected the fashion industry even before it has lately been focused to interior and technical sector. Missoni design house founded in 1953 in Italy, reinterpreted the textiles for fashion and created their signature zigzag and stripe effects with inherited family business's old warp knitting machinery, previously used to manufacture shawls. The Missonis have, with an artist's eye for colour and pattern, worked their myriad textures and designs into the most instantly recognizable knitwear in the world [11].



Figure 2. A-POC by Issey Miyake (1999) [8]

Knitting has for some time been characterized by the network of technologies within the knitting industry. The knitters keep inspiring one another. Improvements developed within a specific knitting area stimulate the development and implementation of ideas in other knitting areas. The interlacing of technologies has recently been extended beyond the frame of the knitting industry. In addition to the already established concept of complementing various textile technologies (knitting, printing, embroidery, sewing, etc.) to achieve the greatest possible design and functional performance, there is also a marked merging of mechanical and chemical textile technologies [12]. The keyword in contemporary knitting is undoubtedly circulation of technologies, knowledge and innovation.

#### **TURNING POINTS IN MACHINE KNITTING: EVER EVOLVING TECHNOLOGY**

Historical experts can not agree about when and where the human race first learnt to make loops of a yarn and connect these loops to a textile structure. The technique of knitting was probably first practiced in the areas of the Mediterranean and Asia. Findings during excavations in Egypt confirmed that hand knitting had already been discovered as early as 5th century [13].

Hand knitting became mechanized in 1589, with the invention of the stocking knitting frame by William Lee of Nottinghamshire. [11]. The knitting frame was able to simultaneously produce 16 stitches in the same time needed by a skilled hand-knitter for just one stitch [14]. This gave greater

speed of production but necessitated the use of flat fabric, and temporarily the ability to create the complete garment in the round was forsaken. Technical developments continued steadily throughout the eighteenth, nineteenth and twentieth centuries, giving rise to a range of fundamental knitted fabric structures. It has, however, taken until recent decades for the most sophisticated industrial machinery to be able to replicate the garment-making skills achievable by hand by the round on four or five needles and practiced for centuries [11].

During seventeenth century several improvements were made to the original Lee's machine, but it still functioned using a horizontally arranged needle bar. It was estimated that by the end of the seventeenth century there were between 7700 and 800 machines in operation in England [13]. Important further developments were made by Jedediah Strutt, who in 1759 built a frame for rib knitting, still operating on the same principle as the first Lee's frame [10,13]. Strutt's frame was the first major technical advance in machine knitting. Until his invention the technical improvements had been focused mostly to finer machine gauge. A few decades later, warp knitting was first developed by Crane and Porter in 1769 as a method of embroidery plating, by means of multiple warp thread guides, onto stocking fabric as it was being knitted on the hand frame. As the technique improved, purely warp intermeshed loop structures without the weft knitted ground began to be knitted and Crane patented his warp loom in 1775. It became the basic principle for both warp looms as well as Raschel looms [10,13].

At the beginning of the 19th century the knitters came across a serious economic crisis because of overproduction. The machines were given the blame and the Luddis started an action through which several hundred machines were destroyed [13]. In 1864 William Cotton had turned the Lee's principle upside down by arranging the needlebar vertically and giving it a movable action. By eliminating two movements in the loop forming cycle, the machine could run faster. The cotton machine was also built with several needlebars, which meant a greater increase in production capacity [13]. The most important is that the cotton technology automated the production of fashion shaped articles and developed the full potential of loop transfer shaping [10]. Further development of fully-fashioned technology together with increased patterning possibilities including double structures was only seen at the end of the twentieth century when V-bed knitting machines with shaping possibility were launched.

The first circular knitting machines were built using bearded needles and were mainly aimed at the production of stocking articles; they were built by French inventor LeFroy in 1808 and English engineer Marc Brunel in 1816 [13], who arranged the needles in a circular form rather than a flat bed. The machine produced a tube of fabric suitable for cut-ups, but it could not create fully-fashioned work and had many problems [15].



The great revolution concerning the building of knitting machines came after 1849 when the Englishman Matthew Townsend patented the latch needle [13]. Townsend later sold the rights of his latch needle and emigrated to Canton, Massachusetts in 1858. In 1865 he was successfully sued for infringing the American latch needle patent of James Hibbert, which pre-dated his own by a mere month and four days. In his defence, Townsend stated that latch needles had been in use in France for many years, but he was unable to provide evidence [10].

Approximately at the same time, a compound needle with a sliding latch was first patented by Jeacock of Leicester in 1856. Further developed, it now dominates the warp knitting industry after suffering a set-back against high-speed bearded needle machines in the 1960s. However, in weft knitting, where versatility and needle selection are as important as knitting speed, it has only made limited inroads in certain specialist areas [10]. However, in 1999 at ITMA in Milan, Shima Seiki introduced a new slide needle for V-bed knitting machines that has demolished the primacy of the latch needle and has spread out the pattern possibilities of the whole garment knitting [9].

Shortly after the invention of latch and first slide needles, Isaac W. Lamb, with the help of Townsend and Groz succeeded at constructing a flat machine with individually moving needles in 1863. He enabled the needles to move individually with the help of cams—never before were so many different patterns available at hand [16]. The technique of individually moving needles is another major invention which still dominates the weft knitting while the technique using needles fixed in the needlebed is characteristic for warp knitting.

The most important development connected to automatic circular knitting machines for stockings and socks, however, happened in America. Scott and Williams filed their first patent for circular knitting machines in 1890 and were for many years the leading producer of such machines [13].

In 1910 the firm Robert Walter Scott in Philadelphia was granted a patent for interlock fabrics. In 1918 the first double-cylinder small circular knitting machine with a double hook needle and sliders was built in England by the firm Wildt. It was used for producing „Derby” socks [14]. So, at the beginning of the twentieth century, apart from single and rib knits also interlock and links-links structures became available in machine knitting.

As mentioned before, patterning possibilities were the key for the machine knitting development. Until machine jacquard knitting was possible, hand knitting still played a vital role in the knitting sector. In 1920s circular knitting machines for the fabrication of colour patterned fabrics were used along with flat knitting machines. Patterning was done with the help of yarn strippers and needle selection via pattern wheels and pinched tapes made from steel and paper [14]. The company founded

by Stoll has also played an important role in the development of flat knitting machinery. In 1926 they presented the first motor-driven jacquard flat machine. In 1975 they introduced the first fully-electronic flat machine while in 1987 they launched the first of the CMS series machines [10].

However, the era of electronics began already at ITMA Hannover in 1963. The first electronic needle selection was demonstrated by the firm Morat on its film-taper-controlled circular knitting machine Moratronik, which later got into a serial production [14,17]. In the 1980s computerized knitting machines have already become a standard for up-to-date industrial knitting. Ever since the first SNC Shimatronik model was developed in 1978, Shima Seiki has been at the forefront of computerized knitting technology along with Stoll who launched CNCA-3 at ITMA Hannover in 1979 [18,19]. At the turn of the millennium, new and efficient software was based on Windows PC and standardized desktop. Windows prevailed by all the flat, circular and weft knitting machines producers. In flat knitting, the in-house CAD/CAM systems are still predominant, while parallelly developed universal (generic) systems disappeared from textile shows and exhibitions [9].

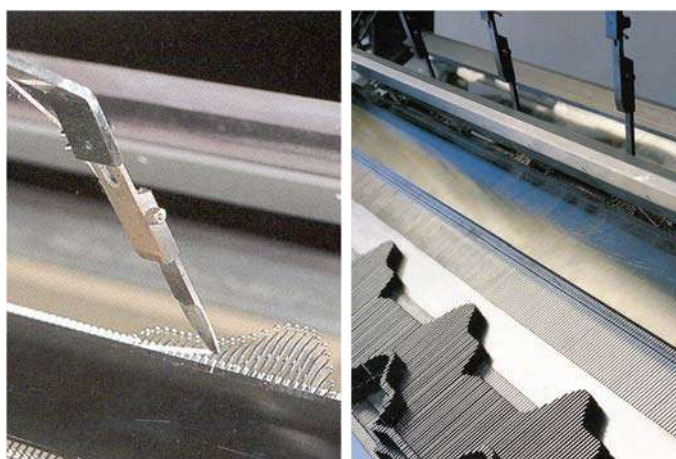

Figure 3. The TFK Tsudakoma carriageless knitting [20]

Apart from wholegarment and seamless knitting, the real new and revolutionary knitting invention from the end of the twentieth century was carriageless knitting, launched by Tsudakoma, otherwise a manufacturer of weaving machines. It drew the biggest public attention at that time. The model TFK, operating without cam-boxes was displayed at the 1995 ITMA exhibition as a trial model. The Asahi Kasai Co. supported and patented the early development of that epoch-making knitting mechanism in 1989. Individual linear electric motors drove the needles in their tricks. The computer and control system regulated the linear motors to simulate the conventional actions of the knitting and transfer cams. As each course of knitting took place, the knitting curves or waves of the needles were clearly visible (Figure 3). The yarn ran from the package to the yarn guide in a direct line via a yarn tensioner and knot catcher. Various problems have been encountered, particularly due to the

absence of brushes, latch openers or stitch pressers, which were usually attached to the cam-carriage. The greatest disadvantage were, however, the cost of the machine in comparison with conventional V-bed machines [10,20,21].

At the beginning of the twenty-first century the trend of higher and higher production speeds became essential. Machine constructions were lighter, they also included composite materials replacing metal in machine frames and knitting parts, which represented an „out of the box” approach to the knitting-machine building. Machine designs were more ergonomic and above all the machines heights were reduced. Machine parts that were needed for yarn manipulation were easier to reach by machine operators. Obviously, the machine builders answered the demands of the Asian markets [22].

The revolutionary innovation of the twenty-first century is undoubtedly the new spin-knit concept in which two processes: spinning and circular knitting are merged. The combined technology clearly shows the direction of knitting development: the shortest time possible and the minimal space necessary for the manufacture from raw material to a finished product. At two successive ITMA exhibitions, 2007 Munich and 2011 Barcelona, three circular knitting companies presented combined spin-knit machines. Maye&Cie system spins directly yarn from rovings that are mounted close to the machine and then subsequently knits the spun yarn. Terrot uses an air-jet spinning system. However, it does not mount the rovings, clearing or drafting units or the spinning nozzles on the knitting machine itself. Instead, there is a creel type arrangement on three sides of the machine, which houses the complete roving to spinning process. The yarns are spun by the side of the machine and then fed in. The independent spinning unit can be fitted to all Terrot single-jersey and double-jersey machines.



Figure 4. Pai Lung's SPINIT technology [23]

Unlike Mayer& Cie and Terrot, the Pai Lung process commences with a stream of parallel slivers that are fed through a drawing frame via a spinning unit into a single-jersey knitting machine (Figure 4). A false twist is applied to spin the yarn [23].

All three solutions can shorten the production process making separate ring spinning, cleaning and rewinding steps no longer required, which lowers production costs. This also leads to a significantly lower investment in machinery.

## THE REVIVAL OF HAND KNITTING

Not so long ago, hand knitting was seen as an ordinary and unchanging indoor activity and, in its domestic history, it was the occupation of older women making products of dainty work and taste [24]. Today, hand knitting deals with rural as well as urban population of all classes. The popularity of leisure hand knitting and crocheting is increasing; moreover, hand knitting is becoming more and more widespread among young urbans. With the emergence of hobby and artistic handicraft markets, hand-knitting and crocheting have developed into a profitable market activity.

Positive effects of hand knitting have become increasingly important: from generating imagination, creativity and innovation, even humor, through knitting and socializing in groups, to medical and therapeutic effects as well as trade, social and global connections. Knitting became means of communication, artistic and social expression, statement, trend, way of life, etc.

The advantage of hand knitting are its flexibility and mobility. One can knit almost everywhere, at home, in a park, in a café or public transportation. For hand knitting, only a ball of yarn and knitting needles or a crochet are required. Hand-knits are colorful, they have a nice touch, they can be 3D knitted/shaped, they are custom-made and therefore personalized.

In the last decade, there has been a resurgence of interest in knitting as a form of leisure. From „stitch 'n bitch” groups and pub knitting circles to fiber festivals and knit meets, new public sites for participating in knitting have emerged as part of a contemporary craft movement (Figure 5). Accompanying this renaissance is a growing presence of „craftsters” on the web, with blogs, podcasts, social networking sites and folksonomies like Flickr and YouTube connecting a global community of knitters and providing them with a wealth of resources and support. Knitters photograph and blog about their projects and yarns, chat and plan face-to-face knit festivals via forums, search for podcasts to learn new skills, follow „celebrity” knit bloggers and sell and exchange patterns and yarn via knitting networking sites [25].



Figure 5. Hand knitting at Abilmente hobby fair Vicenza, Italy [26]

The growth of do it yourself (DIY) craft culture, of which knitting is a part, itself has a history that encompasses professional and leisure practices, diverse forms of production and consumption, fine art, performance and fashion with activities spanning public and private spheres [25]. Knitting, along with a number of other lifestyle activities like gardening and cooking, is seen as providing an alternative temporality which allows individuals to create meaning outside of the spheres of domesticity or employment [27]. This nostalgic reclaiming of craft is understood as a response to mass consumerism, globalization and the homogeneity of the high street, reflecting a desire for individualization and a playful and ironic trend for celebrating domesticity in popular culture [25,28].

On the other hand, it was proved that knitting in a group impacts significantly on perceived happiness, improved social contact and communication with others [29]. In 2012, Slovenian group launched the project Connections. Connections was a textile installation in progress. Project offered moments of calm engagement, creative expression, healing remembrance, relaxed socialization to regular people. Visitors were invited to take off shoes, sit down, inspect, touch, and learn simple textile technique, how to make a rug with their fingers. The project connected people by working together on the symbolic textile field – carpet [30].

There is an increasing evidence that engaging in creative and meaningful occupation can impact positively on health and wellbeing. The results of an online survey among more than 300 knitters showed that there was a significant relationship between knitting frequency and feeling calm and happy. More frequent knitters also reported higher cognitive functioning [29]. Knitters control the rhythm of their craft and may change it according to their mood. This rhythm is instantaneously calming [31].

Therapeutic knitting takes the benefits of knitting and enhances them to improve well-being or to treat certain medical conditions. The psychological benefits of knitting alone or within a group

range from distraction, refocusing of attention, and enabling feelings of control to providing rewarding occupation and enabling relaxation and contribution. Through knitting, lost emotions associated with anticipation, pride, excitement, and happiness are reawakened. Life circumstances such as illness, retirement, or redundancy can change identity and perception of self. Knitting can enable the knitter to build a new positive identity through, for example, knitting for charity [31]. Knitting complex patterns can also be beneficial for hand joint exercise and memory training.

Because of the nature of the stitch and the use of a continuous thread, knitted fabrics are very strong and can be used to support large structures. Knitting that appears in unexpected environments, knitting that masquerades, as something it is not, knitting that provokes questions – this is when knitting becomes art [32]. Contemporary artists have revealed new forms of art of knitting by getting out of traditions or by reinterpreting the traditional values [33].

Guerilla knitting also named „yarn bombing”, „yarn storming” or „graffiti knitting” has been used to describe urban social practices of knitted objects placed, or tagged, in public spaces. This amusing new trend encourages young urbanites to wrap colorful knitted fabric around lamp posts, trees, and sometimes entire city buses to brighten the city environment. The fad reportedly started in Texas among young knitters seeking a creative way to use their leftover yarn and unfinished projects. It has since spread worldwide, as the „artists” photograph their installations and share them on the Internet [34]. Guerilla knitting has also spread in Slovenia. In spring 2017, Irena Erzen has dressed street trash bins in Koper and attracted much interest with her temporary urban installations (Figure 6) [35].



Figure 6. Guerilla knitting [36]

## CONCLUSIONS

The historical development shows that machine knitting is an extremely diversified and innovative sector which keeps evolving fast, adapting to market and time requirements. It also merges and combines with other textile and non-textile technologies in order to increase production efficiency, patterning possibilities and quality.

It can be concluded that the recent revival of a hand knitting technique as a hobby that was considered old-fashioned until the last few decades, has become a trendy, socializing and wellbeing activity that can reduce stress, enhance concentration, memory and motoric functions, etc.

Hand knitting can also be a means of art expression or activism as well as profession and a profitable activity. Hand knitting has expanded in all aspects of our lives. Based on the same interlacing principles it represents a counterweight to modern hi-tech industrial knitting.

## REFERENCES

- [1] Techtextil. Directed visitor orientation to your stand [Internet]. Available from: [https://messelogo.de/tt/2019/tt\\_microsite\\_2019/en#anwendungsbereiche](https://messelogo.de/tt/2019/tt_microsite_2019/en#anwendungsbereiche). [Accessed 3rd December 2018].
- [2] Štemberger M, Pavko-Čuden A. Style in knitted textiles and fashion. In: Shaping the future of textiles. Proceedings 17th World Textile Conference AUTEX; 29 - 31 May 2017; Corfu, Greece. IOP conference series, Materials science and engineering. Bristol: IOP Publishing; 2017;254:1-4. Available from <http://iopscience.iop.org/article/10.1088/1757-899X/254/17/172025>. [Accessed 30th November 2018].
- [3] Smirfitt JA. An introduction to weft knitting. Durham: Mellow; 1975. 89 p.
- [4] The history of hand knitting. Victoria&Albert Museum [Internet]. Available from: <https://www.vam.ac.uk/articles/the-history-of-hand-knitting>. [Accessed 3rd December 2018].
- [5] Raz S. Warp knitting production. Heidelberg: Melliand Textilberichte; 1987. 548 p.
- [6] Miyake Design Studio. Main Lines. A Poc [Internet]. Available from: <http://mds.isseymiyake.com/mds/en/collection/>. [Accessed 3rd December 2018].
- [7] MOMA. Issey Miyake, Fujiwara Dai, A-POC Queen Textile 1997 [Internet]. Available from: <https://www.moma.org/collection/works/100361>. [Accessed 5th December 2018].
- [8] Museum of Applied Arts and Sciences. A-POC ensemble by Issey Miyake [Internet]. Available from: <https://collection.maas.museum/object/9704>. [Accessed 6th December 2018].
- [9] Pavko-Čuden A. Development trends in mechanical textile technology at the beginning of new millennium. Novelties in knitting technology. Tekstilec. Ljubljana: Društvo inženirjev in tehnikov tekstilcev; 1999. p. 95-127.

- [10] Spencer DJ. Knitting technology. Cambridge: Woodhead publishing; 2001. 416 p.
- [11] Black S. Knitwear in fashion. London: Thames & Hudson; 2002. 192 p.
- [12] Pavko-Čuden A. ITMA 2015 - Modern knitting: sustainable orientation and circulation of innovations. *Tekstilec*. 2016;59(1):63-75.
- [13] Modig N. Hosiery machines. Bamberg: Meisenbach; 1988. 170 p.
- [14] Iyer C, Memel B, Schäch W. Circular knitting. 2nd revised edition. Bamberg: Meisenbach; 1995. 269 p.
- [15] Hawkins M. A short history of machine knitting. *Knitting history forum* [Internet]. Available from: <http://knittinghistory.co.uk/resources/a-short-history-of-machine-knitting/>. [Accessed 6th December 2018].
- [16] Potočić Matković VM. The Power of Fashion: The Influence of Knitting Design on the Development of Knitting Technology. *Textile*. 2010;8(2):122-146. DOI: 10.2752/175183510X12791896965493.
- [17] Revolutionary inventions. 100 years of Framo Morat. An eventful century [Internet]. Available from: [https://framo-morat.com/wp-content/uploads/FRA11109\\_Jubilaeumsbroschuere\\_en\\_Screen.pdf](https://framo-morat.com/wp-content/uploads/FRA11109_Jubilaeumsbroschuere_en_Screen.pdf). [Accessed 6th December 2018].
- [18] The obvious Choice. Shima Seiki [Internet]. Available from: <https://www.knittingindustry.com/uploads/367/sig-seriese.pdf>. [Accessed 4th December 2018].
- [19] Milesotnes, History. Stoll [Internet]. Available from: [http://stoll.com/company/milestones/5\\_4](http://stoll.com/company/milestones/5_4). [Accessed 6th December 2018].
- [20] Srdjak M, Pavko-Čuden A. ITMA '95 - new developments in the field of knitting. *Tekstil*. 1996;45(4):205-213.
- [21] Itoh S. Retrospect of textile machinery in the 5th OTEMAS. *Journal of the Textile Machinery Society of Japan*. 1994;40(2):39-48.
- [22] Pavko-Čuden A. ITMA 2007 - Knitting technology: higher production speed and finer gauge. *Tekstilec*. 2008;51(ITMA 2007):51-62.
- [23] West A. ITMA 2016 Technology: Knitting. *Textile World* [Internet]. 2016; 14th February. Available from: <https://www.textileworld.com/textile-world/knitting-apparel/2016/02/itma-2016-technology-knitting/>. [Accessed 2nd December 2018].
- [24] Vacchani SJ. (Re)creating objects from the past – affect, tactility and everyday creativity. *Management & Organizational History* [Internet]. 2013 [cited 2018 Dec 10];8(1):1-104. Available from: <http://dx.doi.org/10.1080/17449359.2013.750052>.
- [25] Orton-Johnson K. Knit, purl and upload: new technologies, digital mediations and the experience of leisure. *Leisure Studies* [Internet]. 2014 [cited 2018 Dec 10];33(3):305-321. Available from: <http://dx.doi.org/10.1080/02614367.2012.723730>.



- [26] Media Gallery – Abilmente Vicenza. Abilmente: la festa della creatività. [Internet]. Available from: <https://www.abilmente.org/it/vicenza/media-gallery>. [Accessed 1st December 2018].
- [27] Parkins W. Celebrity Knitting and the Temporality of Postmodernity. 2004;8(4):425-442. Available from: <https://doi.org/10.2752/136270404778051564>. [Accessed 7th December 2018].
- [28] Greer B. Knitting for good! A guide to creating personal, social and political change, stitch by stitch. Boston, MA: Trumpeter books; 2008. 228 p.
- [29] Riley J, Corkhill B and Morris C. The Benefits of Knitting for Personal and Social Wellbeing in Adulthood: Findings from an International Survey. British Journal of Occupational Therapy. 2013;76(2):50-57.
- [30] Oloop. Connections [Internet]. Available from: <http://www.oloopdesign.com/en/projects/connections/>. [Accessed 7th December 2018].
- [31] Corkhill B, Hemmings J, Maddock A and Riley J. Knitting and Well-being. Textile, 2014;12(1):34-57.
- [32] Black S. Knitting fashion, industry, craft. London : V&A Publishing; 2012. 240 p.
- [33] Tavman MB, Oskay N. Knitting in art. In: CORTEP 2012. IFKT 2012. Proceedings of 46th International Congress IFKT; 6 - 8 September 2012; Sinaia, Romania. Iași: Performantica; 2012.
- [34] McIntosh B. Knitting. A craft comes back. English Teaching Forum [Internet]. 2012 [cited 2018 Dec 2];(1):36-43. Available from: [https://americanenglish.state.gov/files/ae/resource\\_files/49\\_1\\_6\\_feature-article.pdf](https://americanenglish.state.gov/files/ae/resource_files/49_1_6_feature-article.pdf)
- [35] Pavko-Čuden A. Multiple faces of contemporary hand knitting. In: Shaping the future of textiles. Proceedings 17th World Textile Conference AUTEX; 29 - 31 May 2017; Corfu, Greece. IOP conference series, Materials science and engineering. Bristol: IOP Publishing; 2017;254:1-6. Available from <http://iopscience.iop.org/article/10.1088/1757-899X/254/17/172025>.
- [36] Gverilsko pletenje Irene Eržen vas ne bo pustilo hladnih. Ekoper [Internet]. 2017 March 18th [cited 2018 Dec 10]. Available from: <https://www.ekoper.si/kultura/gverilsko-pletenje-irene-erzen-vas-ne-bo-pustilo-hladnih/>.

# SELF-FOLDABLE KNITTED STRUCTURES

**Darja RANT<sup>1</sup>, Alenka PAVKO-ČUDEN<sup>2\*</sup>**

<sup>1</sup>Klobbka, d.o.o; Spodnja Luša 25, 4227 Selca, Slovenia

<sup>2</sup>University of Ljubljana, Faculty of Natural Sciences and Engineering, Department of Textiles, Graphic Arts and Design, Snežniška 5, 1000 Ljubljana, Slovenia, \*email: alenka.cuden@ntf.uni-lj.si

---

## ABSTRACT

*Contemporary textile and clothing producers are focused in development of products with innovative characteristics that can represent an important added value. This objective can only be achieved by merging knowledge and skills of experts from various areas including craft, industrial design, materials, production technologies, marketing, psychology, ecology, etc. The properties and the characteristics that were initially developed for products for special use are nowadays often present in functional textiles for everyday use which can be distinguished by multiple functions. Contemporary multifunctional textiles are based on innovative design as well as on hi-tech mechanical and/or chemical functionalization. Knitted structures can be relatively rapidly designed and produced in a variety of structures due to their composition of various interlacing loop elements and their combinations. Self-foldable weft knitted structures exist in a wide range of forms from simple rolls, ribs, pleats to more complex three-dimensional structures. They exhibit new kind of geometry and deformation mechanisms. Some of them have auxetic potential. Self-foldable knitted structures are multifunctional and widely usable. They can be produced in a variety of textures, qualities and dimensions: in panels, fully-fashioned or seamless. Their possible application lies in different fields, such as fashionable and functional clothing, sportswear, medical care, packaging, interior design, sound and shock absorption, etc. The paper presents and reviews many forms, properties and the multifunctionality of self-foldable weft knitted structures.*

## KEYWORDS

*knitted structures, self-foldable, collapsible, multifunctional*

---

## INTRODUCTION

### REVIVAL OF MULTIFUNCTIONALITY

The origins of functionally optimized product design can be traced all the way back to classical antiquity. The writings of the Roman artist, architect, and military engineer Vitruvius ( ca. 80 – 10 B.C.) are among the oldest surviving architectural documents. In chapter three of the first of his ten books entitled *De architectura libri decem*, Vitruvius names a guiding principle that has found its place in design history: „All buildings must satisfy three criteria: strength (*firmitas*), functionality (*utilitas*), and beauty (*venustas*)” [1].

Louis Henry Sullivan, also an architect, is famous for his axiom, “form follows function” which became the touchstone for many architects and designers [2]. He also believed that ornamentation must be derived from nature, as he explained in his essay *The tall office building artistically considered*: „It is the pervading law of all things organic, and inorganic, of all things physical and metaphysical, of all things human and all things super-human, of all true manifestations of the head, of the heart, of

the soul, that the life is recognizable in its expression, that form ever follows function. This is the law” [3].

Useful objects, developed through human history, first served for several purposes; initially, they were multifunctional, since according to the Oxford dictionary [4], *multifunctional* means „having or fulfilling several functions”. Gradually, they became specialized, which means that more and more were needed for everyday use. Therefore, multifunctional objects are as old as mankind. After a long period of excessive consumerism expressed in specialized products, it seems that we have finally focused on fewer but combined and more efficient multifunctional objects and processes. We have entered an era which grants a new meaning to the multifunctionality due to hybridization of materials and engineering techniques, e.g. highly multifunctional materials, with folded materials and knitted structures among them [5].

Nowdays, consumers keep demanding textiles and clothing with hi-performance properties, even in the traditional clothing and home textiles areas. Functional as well as visual appearance are very significant. Many textile and clothing producers develop products with innovative characteristics that can represent an important added value. Added value can be achieved by complex engineering design and by merging knowledge and skills of experts from various areas including craft, industrial design, materials, production technologies, marketing, psychology, ecology, etc. The properties and the characteristics that were initially developed for products for special use are nowadays often present in functional textiles for everyday use [5].

Functionalization of textiles aims to improve native properties as well as to impart new functions in the textile products [6]. Functional properties can be defined as all the effects that are beyond the pure aesthetic and decorative functions. They can be obtained either by: (a) the raw material (characteristics of the polymer or additives before fibre forming as well as fibre properties); (b) yarn, fabric or 3D textile construction; or (c) textile finishing, that is by material, mechanical or chemical functionalization [5].

The basic underlying technological need for the development of multifunctional materials is that solutions to particular problems or needs cannot always be found by using a simple combination of materials with different functions, and a technological barrier is reached. The major obstacle to the development of multifunctional materials and systems is, paradoxically, the very thing that gives them their advantage over combinations of single functions – multidisciplinary. That is, the need to pull together and establish close and sustainable links between often disparate and closed disciplines [7] which is a complex and a demanding task.

Multifunctional materials can be both naturally existing and specially engineered [8]. Many of them may draw inspiration from nature, where size and weight are often critical and multifunctionality is a necessity rather than a luxury [7]. The underlying assumption is that nature performs a function

with the least amount of energy, uses the commonest materials, and is the most reliable. Biomimetics is a discipline that seeks sustainable responses to the challenges of modern society by imitating natural, time-tested patterns and strategies. The use of natural concepts and raw materials ranges from biomolecules to macroscopic materials in which structural features and hierarchical organization derive from nature [9]. Biomimetics or mimicry, i.e. copying of properties of familiar objects, organisms, or environments in order to hide them from or deter other organisms, is perhaps the oldest and most efficient method of achieving major advances in design. Surface mimicry is defined as making a design look like something else. Behavioral mimicry is defined as making a design act like something else. Functional mimicry is defined as making a design work like something else [10]. An example of a surface mimicry is a simulation of a coarse knitted structure printed on a very fine knitted fabrics presented by Shima Seiki at Imta 2015 in Milan. An example of behavioral mimicry is a knitted structure which simulates a woven look as presented by Stoll in Capsule Collection Autumn 2016 – „Woven stitches”. Examples of functional mimicry are knitted implants, i.e. grants, stents, meshes for the reconstruction of soft tissue defects, etc.

Knitted structures, especially flat knitted structures can be relatively rapidly designed and produced in a variety of textures due to their composition of many interlacing loop elements and their combinations (front and rear loop, transfer loop, tuck, miss, rack, etc.). They can mimic foldable structures from nature, e.g. hornbeam leaf blooming (Figure 1). Mechanical functionalization involves the design of the structural and geometrical parameters which influence the usability and performance properties of foldable knitted structures. Chemical functionalization upgrades their performance to achieve the ultimate planned characteristics. Furthermore, unlike weaving, flat knitting enables manufacturing of fully-fashioned and seamless products, which means that shaping and real three-dimensional knitting additionally expands the boundaries of the multifunctionality of knitted products [5]. Their possible application lies in different fields, such as hosiery, fashionable and functional clothing, specialized underwear, sportswear, medical care, packaging, interior design, sound and shock absorption, insulation [5], etc.

The objective of the research was to review different forms, properties and functionalities of self-foldable weft knitted structures inspired by nature and to design, on the basis of the previous testing of their performance properties, a series of foldable knitted products. With the presented research we aimed to prove that self-foldable knitted structures present a contemporary, sustainable, multifunctional material with a high aesthetic value and excellent performance potential.

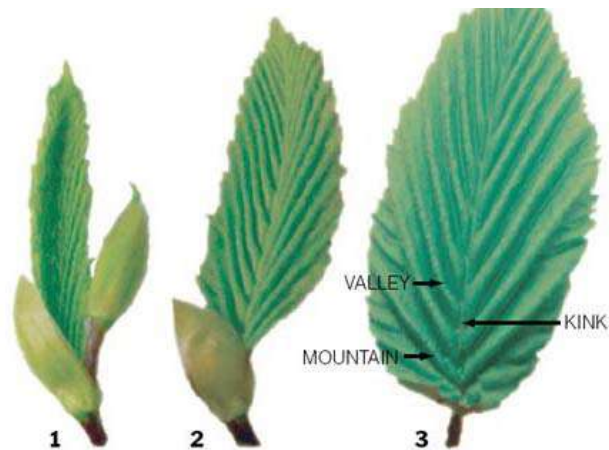

Figure 1. Hornbeam leaf blooming [11]

## FOLDABILITY and self-foldability

### *Origami-inspired structures*

According to the Oxford dictionary [12], *folding* means to be „able to be bent or rearranged into a flatter or more compact shape, typically in order to make it easier to store or carry”. In recent years, more and more designers of all disciplines have turned to folding to create a wide range of handmade and manufactured objects, both functional and decorative. A little time spent looking through design and style magazines will reveal a significant number of folded products, from apparel to lighting and from architecture to jewellery. Origami is one of the most vibrant buzzwords in contemporary design [13]. It is often used as a synonym for folded structures, in knitting as well as in other textile techniques [14].

The science and technology area associated with origami-inspired engineering is new and developing rapidly. It has evolved from aesthetic pursuits to design folding structures across cultures and scales. The underlying principles of origami are very general, which has led to applications ranging from cardboard containers to deployable space structures which can be fabricated, assembled, stored, and morphed only through bending without any cutting and gluing [15,16].

In textiles and clothing foldable structures are a fundamental element of design. Rolls, folds, ribs pleats and bubbles make a flat structure three-dimensional. Redistributed volume causes changes in aesthetic appearance as well as in functional properties like thermal insulation, sound absorption, compression and support, strength, stiffness, handle, etc [5].

Origami-inspired folding of textiles can be performed by various techniques. Woven and nonwoven textiles usually exhibit folded look achieved by pressing or finishing. Folded textiles can also be formed by sewing together parallel stripes of fabric alternately on the face and the rare side. On

the other hand, knitted products can be designed by integrating folds directly into the knitted structure [5].

#### *Everyday foldable textiles and clothing*

The flexibility of textiles allows clothes to be folded and stored when not in use or when prepared for travelling. Anoraks, raincoats and wet-weather jackets can often be folded and stored into a sewn-in pocket. All sailing boats are equipped with sails which are folded and unfolded to meet the weather and wind changes. Nobody takes as much interest in folding their collapsible tool as parachuters. For them, sloppy folding could be fatal. In cars, foldable sunshades made from knitted mesh are used for side windows. Their form is similar to the photographer's collapsible light reflector, invented in 1985 by John Riston. When twisted, the spring coils itself into three smaller rings, making it compact enough to stow away in a small bag. Many modern interior textiles have creased or pleated structure like modern venetian blinds made of textile composites [17]. Therefore, foldable or in wider sense, collapsible [17] objects are true representatives of everlasting, sustainable design.

#### *Foldable fashion accessories, technical fashion and interior design*

Fans were once essential feminine accessories. Foldable fans could be inspired by a peacock tail. They came into use after 1580. They functioned as a temperature controlling device by inducing an airflow over the skin. They could also be used as means for concealing identity [17-19]. Although they now seem to be simple everyday objects, they are in fact historical multifunctional technical devices.

Nowadays, more and more non-textile materials and non-textile technologies are incorporated in textiles and clothing to contribute to their multifunctionality. They are the representatives of the „technical fashion”. Hussein Chalayan is regarded as an inventor, philosopher and architect among fashion designers. He approaches his collections like conceptual artist, frequently interpreting in his designs socially relevant themes such as cultural identity, tradition and migration [20]. He was one of the first designers to engage with technological systems, and many of his collections have pioneered garments that feature wireless technology, electrical circuitry and embedded connectors [21]. For his 2007 collection entitled „One hundred and eleven”, he designed a true collapsible collection of six mechanical transforming dresses, expanding and folding to change the shape and silhouette of the garments with the aid of electronics. The hemlines were raising and lowering, the skirts were expanding and contracting [5].

Japanese artist and designer Issey Miyake is considered revolutionary for his use of materials and its iconoclastic, conceptual approach to fashion. He blends traditional, historical elements of Japanese fashion, such as wrapping and folding, with cutting-edge technological innovation that have

revolutionised fabric manufacturing. His designs demonstrate a desire to expand the potential for clothing outside of the purely functional. He is best known for the technique of pleating silk via a heat treatment, first used in his iconic collection „Pleats Please” in 1993 [22]. He also includes self-foldable links-links knitted structures into his collections. However, the 3D self-foldable structures could only be applied for knitwear after wholegarment technology was introduced; foldable links-links knitted structures might look intriguing and innovative but when composing individual panels into a complete garment by sewing, technical problems occur. And, even if Miyake is well known for his overarching aesthetical-functional concept, in his case the foldability is often a sophisticated visual effect rather than a (multi)functionality effect [5].

Nevertheless, the fact is that fashion and interior design have become a technical issue that comprises superior aesthetic as well as multifunctionality, including collapsibility and foldability.

### *Self-folding*

Self-folding is not exactly a new phenomenon as it frequently appears in nature for the efficient fabrication of structures [23]. It also occurs in textiles. At the fibre level it is shown as self-curling. In the nature, the curling property of wool results from its bilateral structure, where ortho and para cortex are arranged in asymmetrical, side by side order in the cross-section of the fibre. Wool fibres have, because of this difference, a helical crimped configuration. There are also man-made crimped fibres [24].

In flat knitting, some links-links structures exhibit self-folding after exiting the take-down zone (Figure 2). The folded state represents the relaxed, i.e. the passive state.



Figure 2. Self-folding of links-links structures after exiting the take-down zone [5]

## FUNCTIONALITIES OF SELF-FOLDABLE KNITTED STRUCTURES

Knitting process allows the production of a vast range of structures. Foldable weft knitted structures exhibit new kind of potential due to their geometry and deformation mechanisms. Creased or folded knits can involve a wide range of structures from simple rolls, ribs, pleats and bubbles to more complex three-dimensional structures [5].

### *Folding effect*

Links-links structures are composed of front and rear loop interlacing elements alternating in both directions, along wales as well as along courses. Links-links knitting enables manufacturing of very aesthetically intriguing fabrics which are flat-knitted but crease and fold after relaxation, forming various textures and spatial patterns (Figure 3). Among them, links-links structures with zigzag or other geometrical patterns are particularly promising as they are rather simple to design and produce [5].

In links-links knitting, folding is based on the structural disequilibrium of face and rear loops which causes the fabric to crease, contract, fold and form into a three-dimensional structure after the take-down and relaxation. Foldable structures shrink in both course and wale directions. Under applied strain in the horizontal or vertical direction, three-dimensional foldable structures smooth into a flat fabric, creases unfold and the structure expands in both directions [14, 25].



Figure 3. Self-folding links-links structures with different distribution of front and rear loops [5,26]

In order to establish the influence of yarn composition and structural parameters such as size of the repeating unit cell on the folding effect of links-links knitted fabrics, a set of experiments was designed by Pavko-Čuden et al. The number of the same type of loops in a course direction needed to



initiate the structure folding effect was also investigated. It was concluded that the yarn material composition, the size of the repeating unit cell and the width of the zigzag line at the constant number of courses in the repeat, significantly influence the folding ability of links-links knitted structure. It was also established that additional PA monofilament stiffens the structure and increases the folding tendency. The investigation showed, that the loop density has a significant impact on the folding tendency of the knitted structure [14, 27].

#### *Auxetic potential*

Auxetic materials are different from most conventional materials in that they exhibit a negative Poisson's ratio (NPR). They expand laterally when stretched and contract laterally when compressed [28]. This counterintuitive behaviour gives auxetic materials various beneficial effects, such as enhanced shear stiffness, increased plane strain fracture toughness, increased indentation resistance, and improved energy absorption properties [29,30]. As the Poisson's ratio is a physical parameter that is independent of the material scales, the auxetic behaviour can be achieved at any material level, from molecular to macroscopic [31,32].

Flat knitting technology can provide a simple, but highly effective way of fabricating auxetic fabrics from conventional yarns. 3D geometry of specially developed links-links knitted structures (Figure 4) enables a new deformation mechanism called „opening of the folded structure”. The fabrics that are more closely folded can result in a smaller opening angle and consequently have higher NPR values. A negative Poisson's ratio as low as  $\nu=-0.5$  was reported in the scientific literature for such structures; nevertheless, the examined fabrics exhibited auxetic effect only in one direction [25].

The purpose of the investigation of the foldable links-links knitted structures by Drol and Pavko-Čuden [33] was to compare auxetic properties of foldable links-links knitted fabrics made of different yarns, on flat knitting machines with different gauges, different densities of knitted structure and different repeats. Foldable zigzag ribbed structures with auxetic potential were produced from different conventional yarns. The yarn selection was based on the material composition, which affects the elasticity and stiffness of the yarn, and thus the anticipated rigidity, stability and folding of the zigzag rib knit structure with auxetic potential. It was found that in most cases the samples exhibit the highest auxetic effect at 60-90% extension. Knitting with 45° inclination of ribs exhibits the best folding tendency. Fabrics produced on knitting machines with finer gauge exhibit higher auxetic effect. Material composition and knitting machine gauge have a great impact on the Poisson's ratio of foldable links-links knitted fabrics with zigzag ribs [33].

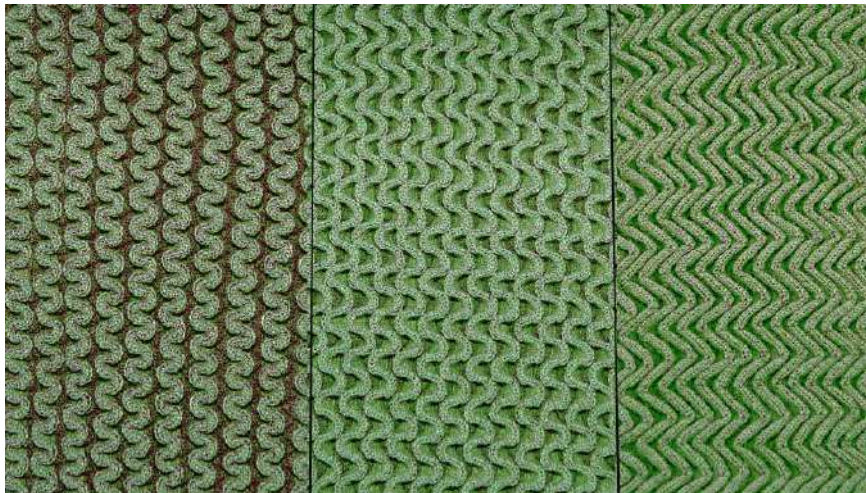

Figure 4. Foldable knitted structures with auxetic potential [34]

### *Compression resistance*

Compression is one of the important fabric properties, in addition to friction, bending, tension and shear. Compression may be defined as a decrease in intrinsic thickness with an appropriate increase in pressure [35]. The pressure-thickness curve of textile fabrics in lateral compression is highly non-linear [36].

In order to evaluate the behaviour of links-links weft knitted fabrics with a zigzag structure under compression, the same series of samples as for the folding effect were examined. Since the width of zigzag lines influences the folding ability, only the compression properties of fully folded knitted structures were examined. It was found out that the structures with the square repeat which were all fully folded exhibited a gradual compressive stress decrease, while for the structures designed with various widths of zigzag ribs, an instant drop of compressive stress was evident. It was concluded that for the compression of the examined foldable knitted structures to the thickness of 1mm, substantial loads are required [37].

### *Sound insulation*

During recent years, the subject of noise has received increasing amount of attention to the scientists, technologists and public as a whole. For a healthy and a pleasant environment, controlling the sound hazards is an important issue. There is a medical evidence, that the human body will take sound as „pollution” if the ambient sound levels exceeds 65dB. Therefore, unwanted and uncontrolled noise should be reduced using noise barriers and noise absorbers. Sound absorbing materials are commonly used to soften the acoustic environment of a closed volume by reducing the amplitude of

the reflected waves. Many natural and man-made raw materials have been used as sound absorbers [38-40].

To evaluate the sound absorbing potential of foldable links-links knitted structures, different three-dimensional flat weft knitted fabrics made from various yarns were produced and treated with hardening agents. The sound absorption coefficient of the foldable knits was measured by the impedance (Kundt) tube method. The results were compared to the sound insulation performance of the commercial woollen felt. The final results showed that the investigated foldable structures can be used as sound insulating material as they exhibit good sound absorption properties. Further interesting and attractive foldable structures can be developed for sound insulation with similar thickness, compactness and mass/unit area. Woolen structure showed the best acoustic properties. Hardening agent significantly reduced the sound absorption coefficient. Incorporating nylon into knitted structure improved the stiffness of the structure, but it decreased the sound absorption coefficient in the case of woollen structure [41].

#### *Antibacterial properties*

The suitability of foldable seamless knits for the storage of bread and bakery products has been studied by Rant, Pavko-Cuden and Tomsic. It was assessed by testing the antibacterial properties of the selected foldable knitted structures made from various raw materials compared to single structures [26].

First, the soil burial test according to SIST EN ISO 11721-1:2001 standard was performed for determining the resistances of foldable knitted fabrics made from various yarns to microbiological deterioration. After that, the rate of biodegradation of the examined samples was determined by colour measurement with a spectrophotometer using the CIELAB colour system.  $\Delta L^*$  values of the buried and unburied samples were determined and compared. In order to achieve antibacterial activity, finishing agent was selected, which is chemically alkyl dimethyl (3-trimethoxysilylpropyl) ammonium chloride. Its antibacterial activity is based on bio-barrier formation mechanism. Antibacterial activity of the examined knitted samples was estimated by determination of bacterial reduction according to the ASTM E 2149- 01 standard method. Bacterial reduction of the samples was evaluated against Gram-negative bacteria *Escherichia coli* (ATCC 25922). The results of the study showed that the  $\Delta L^*$  values of the foldable knitted structures were lower than for the single knitted structures. The visual assessment of the samples also showed that in most cases, the foldable knitted structures were less deteriorated than the single knitted structures. The results proved that the foldable links-links knitted structures have better antibacterial properties compared to the single structures. The results also showed that the selected antibacterial finish was fully effective, reflecting in complete growth reduction of the tested bacteria [26].

## EXPERIMENTAL

### DEVELOPMENT OF MULTIFUNCTIONAL SELF-FOLDABLE KNITTED PRODUCTS

The final appearance and structure of knitted products depends on their technological and artistic elements, their interaction and combinations. In addition to the structural characteristics of the raw material (yarn), the parameters of the knitted structure (knitted structure, density, etc.) and finishing (stiffness, lustre, etc.), the artistic elements and their combinations (point, line, color, light-dark, texture, etc.) also affect the final appearance and commercial success of the knitted product. The visual effect of the (self)foldable knitted structures allows for their diverse usability where the aesthetic appearance is as important as their functionality [26].

The current problem with the wider use of self-foldable knitted structures lies in their bi-axial extensibility which is substantially reduced when the foldable panels are sewn together. If joined in the extended state, the folding ability is hindered and the aesthetic appearance of the sewn together piece is affected. If sewn together in a relaxed state, the extensibility is significantly reduced. Flat knitting allows seamless production, therefore seamless foldable links-links knitted products can be manufactured to overcome the manufacturing problems [26].

Real foldable links-links structures knitted from various yarns and tested for different functional properties as described in previous chapter were the basis for the design and development of innovative knitted products.

#### *Household bread storage bag*

Newly developed 3D-knitted (seamless) packaging bags have an attractive, compact look and good folding ability (Figure 5). The inspiration for their design and development derived from nature, where seeds are safely stored in extensible wraps.



Figure 5. Knitted bag for bread storage in passive state (folded and empty) and active state (unfolded and full) [26]

In the folded state, the bag takes up little space, especially in comparison with the bread box. Furthermore, it is decorative, washable and flexible. In the open state, it is well-adapted to the content regarding shape and size. The links-links weft knitted structure allows the redistribution of the volume. The bag can be closed by a clasp or self-closed by self-folding [26]. It is aesthetic as well as multifunctional. The material and mechanical functionalization makes it self-foldable, optimally air-premeable and compression resistant. The chemical functionalization provides preservation of freshness and prevents molding of bread and bakery products.

### *Purse*

Foldable zigzag links-links knitted structure with auxetic potential allows formation of a double curvature or a dome shape. On the basis of this characteristic, an ellipsoid purse (Figure 6) was designed, which, when opened folds in the course direction while zigzagged ribs are only partially folded. The folding of the zigzag structure also enables the compressed, rounded shape of the side parts of the purse and a more voluminous central part. The purse look was developed by computer simulation [26,42]. Knitting of a tubular self-foldable structure on a wholegarment weft flat knitting machine was anticipated.

The material and mechanical functionalization makes the purse self-foldable, optimally compact and compression resistant. The chemical functionalization can provide optimal stiffness, stain-resistancy, water-resistancy, etc.



Figure 6. Foldable bag (Source of photography for computer simulation: DHgate, 2017 [26,42])

### *Pillow*

A double curvature or a dome shape of the foldable zigzag knitted structure with auxetic potential also allows the design of three-dimensional shapes of interior textiles. A simulation of a

decorative pillow is shown on Figure 7. The folding of the tubular zigzag structure enables the voluminous pillow form [26,43].

The material and mechanical functionalization makes it self-foldable and adds a pleasant touch. The chemical functionalization can provide stain-resistancy.



Figure 7. Decorative pillow (Source of photography for computer simulation: Dnevnik, 2017, [26,43])

### *Lampshade*

A simulation of a lampshade is shown on Figure 8 [26,44]. The self-foldable zigzag knitted structure allows the adjustment of the textile shape to the supporting metal frame. As in the previous example, knitting of a tubular self-foldable structure on a wholegarment weft flat knitting machine was anticipated.



Figure 8. Foldable lampshade (Source of photography for computer simulation: Ambientdizajn, 2017 [26,44])

The material and mechanical functionalization makes the lampshade self-foldable and compact. The chemical functionalization makes it stiff and flame-resistant.

#### *Bed cover*

A self foldable knitted structure can also be used in a panel form for a bed cover [26]. In this case there is no problem with the assembly of the components.

The material and mechanical functionalization makes the bed cover self-foldable and pleasant to touch. The chemical functionalization makes it stain-resistant, moth resistant if made from wool and/or hair, etc.

#### *Sound insulation panel and sound absorber*

Self-foldable knitted structures can be used as sound insulating material as they exhibit good sound absorption properties. The knits can be mounted in an extendable frame, used as curtains or pull-walls. They can also be designed as sound diffusors mounted on walls or ceilings. In most cases there is no problem with the assembly of the components.

The material and mechanical functionalization makes the sound insulators and diffusors self-foldable compact and stiff, opaque or transparent. The chemical functionalization can provide additional stiffness, flame-resistancy, stain-resistancy, etc [41].

## **CONCLUSIONS**

Self-foldable knits are very complex materials although their construction is essentially very simple. They exhibit unusual behaviour; for example, auxetic behaviour has already been proved for some zigzag foldable links-links structures. In-depth research into their characteristics, above all into the impact of material, structural and geometrical parameters, finishing, repeated use, textile care, etc. has been very promising. The presented research proved that self-foldable knitted structures present a contemporary, sustainable, multifunctional material with a high aesthetic value and excellent performance potential.

Through development of the presented self-foldable knitted products, their form and function were complemented and the natural concepts were used as starting points. Self-foldable weft knitted fabrics proved to have a big potential for applications in different fields. They can be used for fashionable knitwear as well as for various non-clothing purposes, i.e. interior textiles and household products.

Self-foldable knitted structures exhibit bi-polar attributes. They can be folded or extended, transparent or opaque, flat or curved. They can exhibit multiple forms and are multifunctional at the same time.

A combination of innovative material and mechanical functionalization, i.e. selection of optimal raw materials and intriguing knitted structures, and successive high-performance chemical functionalization can result in new, reusable and recyclable bread storage containers as well as intriguing fashion accessories and interior textiles. Flat knitting allows seamless production, therefore seamless foldable links-links knitted products can be manufactured to overcome the assembly problems.

## REFERENCES

- [1] Bürdek BE. History, theory and practice of product design. Basel: Publishers for Architecture; 2005. 463p.
- [2] Craven J. About Louis Sullivan, Architect. America's First Modern Architect (1856-1924). ThoughtCo [Internet]. 2018 [Updated 15th November 2018]. Available from: <https://www.thoughtco.com/louis-sullivan-americas-first-modern-architect-177875> [Accessed 19th December 2018].
- [3] Sullivan LH. The Tall Office Building Artistically Considered. Lippincott's Monthly Magazine. 1896 March;339:403-409. Available from: [https://ocw.mit.edu/courses/architecture/4-205-analysis-of-contemporary-architecture-fall-2009/readings/MIT4\\_205F09\\_Sullivan.pdf](https://ocw.mit.edu/courses/architecture/4-205-analysis-of-contemporary-architecture-fall-2009/readings/MIT4_205F09_Sullivan.pdf) [Accessed 19th December 2018].
- [4] English Oxford Living Dictionaries [Internet]. Oxford University Press; 2019. Available from: <https://en.oxforddictionaries.com/definition/multifunctional> [Accessed 18th December 2018].
- [5] Pavko-Čuden A, Rant D. Textiles for advanced applications. Rijeka: InTech; 2017. Chapter 3, Multifunctional foldable knitted structures : fundamentals, advances and applications, p. [55-84].
- [6] Multifunctional textiles. SciTechnol [Internet]. Available from: <https://www.scitechnol.com/scholarly/multifunctional-materials-journals-articles-ppts-list.php> [Accessed 17th February 2017].
- [7] Multifunctional materials [Internet]. Materials UK. Reports 2006. Available from: <http://www.matuk.co.uk/docs/Multifunct.pdf> [Accessed 11th February 2017].
- [8] Fedkin M. Multifunctional materials and their impact on sustainability systems [Internet]. The Pennsylvania State University. EME 807: Technologies for sustainability. Available from: <https://www.e-education.psu.edu/eme807/node/698> [Accessed 12th February 2017].
- [9] Raz J. Biomimetics : a molecular perspective. Berlin: De Gruyter; 2013. 252 p.
- [10] Lidwell W, Holden K, Butler J, Elam K. Universal principles of design : 125 ways to enhance usability, influence perception, increase appeal, make better design decisions, and teach through design, 2nd edition. Beverly MA: Rockport Publishers is an imprint of the Quarto Group; 2010. 272



- p.
- [11] The Miura-Ori fold : exploring math and nature through paper folding. Natural origami [Internet]. 2016 [Updated 18th July 2016]. Available from: <https://naturalorigami.wordpress.com/2016/07/18/the-miura-ori-fold/> [Accessed 12th December 2018].
- [12] English Oxford Living Dictionaries [Internet]. Oxford University Press; 2019. Available from: <https://en.oxforddictionaries.com/definition/folding> [Accessed 18th December 2018].
- [13] Jackson P. Folding techniques for designers. From sheet to form. London: Laurence King Publishing; 2011. 224 p.
- [14] Pavko-Čuden A, Rant D, Vilar A. Origami knits. *Knitting international*. 2014;120(2):28-31.
- [15] Peraza-Hernandez EA, Hartl DJ, Malak RJ Jr and Lagoudas DC. Origami-inspired active structures: A synthesis and review. *Smart Materials and Structures*. 2014; 23(9): 094001. Available from: doi: 10.1088/0964-1726/23/9/094001 [Accessed 13th February 2017].
- [16] An N, Li M and Zhou J. Predicting origami-inspired programmable self-folding of hydrogel trilayers. *Letter. Smart materials and structures*. 2016;25(11LT02):8pp. Available from: doi: 10.1088/0964-1726/25/11/11LT02 [Accessed 14th February 2017].
- [17] Mollerup P. Collapsibles. A design album of space saving objects. London: Thames & Hudson; 2001. 232 p.
- [18] Ginsburg M, Hart A, Mendes VD. Rothstein (ed). 400 years of fashion. London: V&A publishing; 1984. 179 p.
- [19] Cumming V, Cunnington CV, Cunnington PE. The dictionary of fashion history. Oxford, New York: Berg; 1976. 320 p.
- [20] Schmidt P and Stattman N. Unfolded. Paper in design, art, architecture and industry. Basel, Boston, Berlin: Birkhäuser; 2009. 255 p.
- [21] Quinn B. Textile Futures. Fashion, design and technology. Oxford, New York: Berg; 2010. 320 p.
- [22] Smith MO, Kubler A. Art/Fashion in the 21st century. London: Thames & Hudson; 2013. 320 p.
- [23] Tolley MT, Felton SM, Miyashita S, An B, Rus D and Wood RJ. Self-folding origami: Shape memory composites activated by uniform heating. *Smart materials and structures*. 2014;23(9):094006. Available from: doi: 10.1088/0964-1726/23/9/094006 [Accessed 18th February 2017].
- [24] Demšar A, Sluga F. Crimped polypropylene yarns. *Kovine zlitine tehnologije*. 1999;33(6):523-526.
- [25] Liu Y, Hu H, Lam JKC and Liu S. Negative Poisson's ratio weft-knitted fabrics. *Textile Research Journal*. 2010;80(9):856-863.
- [26] Rant D. Development of multifunctional 3D knitted structures with auxetic potential [Doctoral thesis]. Ljubljana: University of Ljubljana; 2018. 213 p.
- [27] Blaga M, Ciobanu AR, Pavko-Čuden A, Rant D. Production of foldable weft knitted structures with

- auxetic potential on electronic flat knitting machines. *Melliand international*. 2013;19(4):220-223.
- [28] Evans KE, Nkansah MA, Hutchinson IJ and Rogers SC. Molecular network design. *Nature*. 1991; 353(6340):124. Available from: doi: 10.1038/353124a0 [Accessed 5th May 2015].
- [29] Evans, KE in Alderson, A. Auxetic materials: Functional materials and structures from lateral thinking!. *Advanced Materials*. 2000;12(9):617-628.
- [30] Yang W, Li ZM, Shi W, Xie BH in Yang MB. Review On Auxetic Materials. *Journal of Materials Science*. 2004; 39(10):3269-3279.
- [31] Grima JN, Farrugia PS, Gatt R and Attard D. On the auxetic properties of rotating rhombi and parallelograms: A preliminary investigation. *Physica status solidi (b)*. 2008;245(3): 521-529.
- [32] Liu Y. and Hu H. A review on auxetic structures and polymeric materials. *Scientific Research and Essays*. 2010;5(10):1052-1063.
- [33] Drol P, Pavko-Čuden A. Auxetic properties of zigzag links-links knitted structures with various material composition. In: Simončič B (ed.), Tomšič B (ed.). *Napredne tekstilije za družbo in gospodarstvo. Proceedings, Zbornik izvlečkov 45. simpozij o novostih v tekstilstvu*; 3. June 2014; Ljubljana, Slovenia. Ljubljana: Naravoslovnotehniška fakulteta, Oddelek za tekstilstvo; 2014. p. 30.
- [34] Pavko-Čuden A, Rant D. Design of knitted bags for household bakery packaging and storage. In: *Stepping into the future. Proceedings, 49th IFKT International Congress, Stepping into the future*; 2 - 4 October 2018; Łódź, Poland. Łódź: Instytut Włókiennictwa; 2018.
- [35] Murthyguru. Novel approach to study compression properties in textiles. *Autex Research Journal*. 2005;5(4):176-193.
- [36] Huang W, Ghosh TK. Online measurement of fabric mechanical properties: Compressional behavior. In: *IEEE Annual Textile, Fiber and Film Industry Technical Conference: Proceedings*, 4-6 May 1999, Atlanta, USA. Available from: doi: 10.1109/TEXCON.1999.766185 [Accessed 10th February 2017].
- [37] Rant D, Ciobanu R, Blaga M, Pavko-Čuden A. Compression of foldable links-links knitted structures. *Textil ve Konfeksiyon*. 2014;24(4):349-355.
- [38] Shoshani Y, Yakubov Y. Numerical assessment of maximal absorption coefficients for nonwoven fiber webs. *Applied Acoustics*. 2000;59(1):77-87.
- [39] Hong O. Hearing loss among operating engineers in American construction industry. *International Archives of Occupational and Environmental Health*. 2005;78(7):565-574.
- [40] Mikolajczyk H, Cieslewicz A. Auditory threshold and the degree of its temporary and permanent shifts in the textile industry workers. *Medycyna Pracy*. 1982;33(1-3);57-64.
- [41] Zakrajšek Š, Vilar A, Tomšič B, Simončič B, Sadar A, Pavko-Čuden A. 3D foldable knitted structures for sound absorption. In: *CORTEP 2016. Proceedings CORTEP 2016, 16th Romanian Textiles and Leather Conference*; 27-29 October 2016; Iași, Romania. Iași: Performantica; 2016. p. 216-221.

- [42] Wholesale - 2016 New Luxury Women Oval-shaped Small Totes Handbags Ladies Clutch Bags Purses for Party/Wedding Women Shoulder Messenger. Dhgate [Internet]. Available from: <https://www.dhgate.com/product/2016-new-luxury-women-oval-shaped-small-totes/396102262.html#s1-21-1;onsh|3285860401>. [Accessed 3rd September 2017].
- [43] Najnovejši trendi v notranjem opremljanju združujejo funkcionalnost z dizajnom. Dnevnik [Internet]. 2017. Available from: <https://www.dnevnik.si/1042762562>. [Accessed 28th August 2017].
- [44] Prostoren dom v skandinavskem stilu. Ambientdizajn [Internet]. 2017. Available from: <http://www.ambientdizajn.si/ambient/prostoren-dom-v-skandinavskem-stilu>. [Accessed: 27th August 2017].

**Environmental aspects & energy  
management**



# ANTIMICROBIAL METAL/METAL OXIDE NANOPARTICLES ON TEXTILES

Iva REZIĆ<sup>1\*</sup>, Maja SOMOGYI ŠKOC<sup>1</sup>, Lela PINTARIĆ<sup>1</sup>, Ivan KOSALEC<sup>2</sup>, Vanja LJOLJIĆ BILIĆ<sup>2</sup>, Ivan POKROVAC<sup>2</sup>, Tena TOMIĆ<sup>1</sup>, Karla LALIC<sup>1</sup>, Suzana JAKOVLJEVIĆ<sup>3</sup>

<sup>1</sup>University of Zagreb Faculty of Textile Technology, Prilaz Baruna Filipovića 28a, 10000 Zagreb, Croatia, \*email: iva.rezic@ttf.hr

<sup>2</sup>University of Zagreb Faculty of Pharmacy and Biochemistry, Schrottova 39, 10000 Zagreb, Croatia

<sup>3</sup>University of Zagreb, Faculty of Mechanical Engineering, Ivana Lučića 5, 10000 Zagreb, Croatia

---

## ABSTRACT

*Metal and metal oxide nanoparticles have excellent antibacterial and antimicrobial protective properties. The importance and advantages of nanoparticles have been recognized by many different industries, as well as textile industry, so there are many interesting new materials on the market, such as medical textiles or sports wardrobe. However, due to wide usage of nanoparticles, they are released in huge amounts to the environment from textile wastewaters and laundries. In addition, a threat to the environment present waste textile materials coated with nanoparticles if such materials are not properly disposed after their usage. By influencing the microorganisms in the environment, nanoparticles can have a huge impact on the environment. Therefore, this research presents investigation of impact of antimicrobial metal and metal-oxide nanoparticles on different antimicrobial species, with the perspective of application on textiles.*

## KEYWORDS

*nanoparticles, antimicrobial impact, environment*

---

## INTRODUCTION

Nanoparticles are found in many types of different technological and scientific applications and innovations, from delicate electronics to *state-of-the-art* medical treatments. Textile industry has recognized the importance of polymer materials coated with nanoparticles, and utilizes them widely due to their excellent antibacterial, antimicrobial, water resistance and protective properties. Such materials are found in woven and nonwoven materials such as geotextiles, protective clothing, sportswear, food packaging and automobile interior fabrics [1].

The use of metal particles smaller than 100 nanometers have been used since the Middle Ages for decorative effects of church ornaments and ornamental pottery [2-5]. Nevertheless, today nanotechnology has application in almost every part of our technological and industrial development. Particularly interesting is the application of nanotechnology in the field of medicine and biomedicine, and the most powerful medical research related to nanotechnology is focused on various therapies. Thus, for example, the inclusion of chemotherapeutics in a nanoparticle complex and the coupling of nanoparticles with molecular ligands targeting the cancerous cells provide the ability of chemotherapy

to increase efficiency with reduced side effects and drawbacks [6]. The alternative strategy for the use of nanoparticles in cancer therapy is the so-called photo-thermal ablation of the tumours [7-11].

It is known that nanoparticles of metals and metal oxides also exhibit a favourable biocidal effect against gram-positive and gram-negative bacterial species. The main antibiotic groups currently in use generally target three bacterial targets: cell membrane synthesis, translation machine, and DNA replication [12].

Because of the complexity of nanoparticle interactions and the various systems, the literature is often inconsistent and contradictory, but the action of nanoparticles can be split into two major mechanisms that are interconnected and often occur simultaneously: (1) damage to membrane potential and integrity, and (2) production of reactive oxygen species (ROS), where nanoparticles act as nanocatalysts [13, 14]. Other mechanisms of toxic action of bacterial cell nanoparticles include direct inhibition of specific essential enzymes, induction of nitrogen reactive species (NRS) [15] and induction of programmed cell death-apoptosis [16].

Therefore, the usage of nanotechnology on different polymer materials, especially medical textile, offers huge variety of different applications which could have an influence on bacterial resistance. Many nanoparticles were applied on textile materials and other polymers, and the list is presented in Table 1 [17].

**Table 1:** Nanoparticles on textile and polymer materials [1, 17]

Nanoparticle	Diameter	Nanoparticle	Diameter	Nanoparticle	Diameter
<b>Ag</b>	1.5-350 um	<b>Eu<sub>2</sub>O<sub>3</sub></b>	30 - 58 nm	<b>Pr<sub>6</sub>O<sub>11</sub></b>	15-30 nm
<b>Al</b>	18 or 80 nm	<b>Fe</b>	25 - 250 nm	<b>Si</b>	30-70 nm
<b>Au</b>	50-150 nm	<b>Gd<sub>2</sub>O<sub>3</sub></b>	15-80 nm	<b>SiO<sub>2</sub></b>	15- 80 nm
<b>B<sub>2</sub>O<sub>3</sub></b>	40-80 nm	<b>In<sub>2</sub>O<sub>3</sub></b>	30-50 nm	<b>SnO<sub>2</sub></b>	45-60 nm
<b>CeO<sub>2</sub></b>	15-105 nm	<b>Li<sub>4</sub>Ti<sub>5</sub>O<sub>12</sub></b>	20-60 nm	<b>Ti</b>	30-50 nm
<b>Co</b>	28 nm	<b>MgO</b>	20-100 nm	<b>W</b>	50 nm
<b>Cr</b>	50 nm	<b>Mg(OH)<sub>2</sub></b>	15 nm	<b>Y<sub>2</sub>O<sub>3</sub></b>	20-40 nm
<b>Cu</b>	25 - 500 nm	<b>Mn<sub>2</sub>O<sub>3</sub></b>	30-60 nm	<b>YbF<sub>3</sub></b>	40-80 nm
<b>Mo</b>	70 nm	<b>Ni</b>	20-50 nm	<b>Zn</b>	80 - 130 nm

Although the Table 1 presents many different materials and many different nanoparticles, it was estimated that among all different metal and metal/oxide nanoparticles, silver nanoparticles had the largest degree of commercialization. Therefore it is not surprising that one quarter of all commercial products in which the metal nanoparticles are applied are related to silver products [18, 19].

Today the advents and developments in nanotechnology resulted in a wide span of microorganisms and their enzymes, which can be utilized in the production of nanoparticles. Some examples are presented in Table 2.

**Table 2:** Nanoparticles synthesized by microorganisms [1]

Microorganisms	Nanoparticles	Temperature, °C	Size (nm)	Shape
<i>Desulfovibrio desulfuricans</i>	Pd	25	50	sphere
<i>Enterobacter species</i>	Hg	30	2–5	sphere
<i>Escherichia coli</i>	Cd,Te	37	2.0–3.2	sphere
<i>Fusarium oxysporum</i>	TiO <sub>2</sub>	30	6–13	sphere
<i>Fusarium oxysporum</i>	ZrO <sub>2</sub>	25	3–11	sphere
<i>Lactobacillus species</i>	Ba, TiO <sub>3</sub>	25	20–80	tetragonal
<i>Pyrobaculum islandicum</i>	Cr, Mn, U, Tc	100	different	sphere
<i>Shewanella algae</i>	Pt	25	5	-
<i>Shewanella oneidensis</i>	Fe <sub>3</sub> O <sub>4</sub>	28	40–50	hexagonal
<i>Shewanella oneidensis</i>	Au	30	12 ± 5	sphere
<i>Trichoderma viride</i>	Ag	27	5–40	sphere

Combinations of nanoparticles with proteins allow medical usage of nanoparticles as therapies for effective cancer treatment. But very interesting is their property to act as efficient antimicrobial agents. Such materials can then be applied as efficient medical textiles, and this is research field in which this research group is focused.

In this work, we wanted to present the effects of nanoparticles on model microorganisms, with the perspective of their application on textiles. It is well known that for many balances in the environments, microorganisms have significant and / or vital role. Therefore the purpose of this work is to show the impact of metal nanoparticles and metal/oxide nanoparticles on model microorganism.

## EXPERIMENTAL

### Materials and Methods

In order to prepare efficient antimicrobial polymers, we have modified surface of cellulose polymers and tested their microbial activity. Cellulose materials were modified by using 3-glycidyloxypropyltrimethoxysilane (GLYMO) as a precursor, with the speed of 1 mm/s. Sols were stirred magnetically and afterwards homogenized by ultrasound. Lastly, samples were left to gel at room temperature for 24 hours on room temperature and then heated for 60 minutes at 100 °C.

Modified cellulose cotton samples were investigated by SEM-EDX and FTIR spectroscopic

methods. Firstly the SEM-EDX was performed under the magnification of 80 $\times$ , and then the FTIR measurement was performed. Prior the SEM-EDX investigation, the samples were coated by sputtering device with the Au/Pd. Afterwards the structure and the morphology of samples before and after the modification with the nanoparticles was recorded under the scanning electronic microscope "TESCAN VEGA TS5136LS" with the EDS detector (Figure 1). The parameters used during the measurements are presented in Table 3.

**Table 3:** SEM-EDS instrumental parameters

Working Distance	Energy	Magnification	Detectors	The collection time
25 mm	20 eV	1000 – 10 000 x	1. back scatter detector 2. secondary electrons detector	30 seconds

In order to assess the *in vitro* antimicrobial activity we have investigated different colloidal metal and metal/oxide nanoparticles in a form of certified reference materials with defined properties: Ag (10 and 40 nm), ZnO (100 nm) and TiO<sub>2</sub> (100 nm) on model ATCC-microorganism by serial two-fold micro-dilution assay.

The size of nanoparticles used in antimicrobial testing was investigated and monitored by Nanoparticle Tracking Analyzer Nanosight which can determine the concentration of nanoparticles, as well as their distribution in the system.

## RESULTS AND DISCUSSION

Tested cellulose polymers were investigated according to the norm procedures, and the results are presented in Table 4.

Table 4: Properties of tested cellulose samples and the methods of their characterization

Property	Fiber composition [%]	Mass per unit area [g/m <sup>2</sup> ]	Thickness [mm]	Number of threads in warp [threads/cm]
<b>Norm</b>	HRN ISO 1833: 2003	HRN EN ISO 2286-2:2008	HRN EN ISO 5084: 2003	HRN EN 1049-2: 2003
<b>Sample</b>	100 % cotton	72.26	0.51	54

The SEM-EDX results showed that cellulose materials were successfully modified by uniform homogenous coating which was created over sample surface with equal distribution of metal and metal/oxide nanoparticles. SEM microphotograph of modified cellulose material recorded on samples



after the dip-coating process is presented in Figure 1.

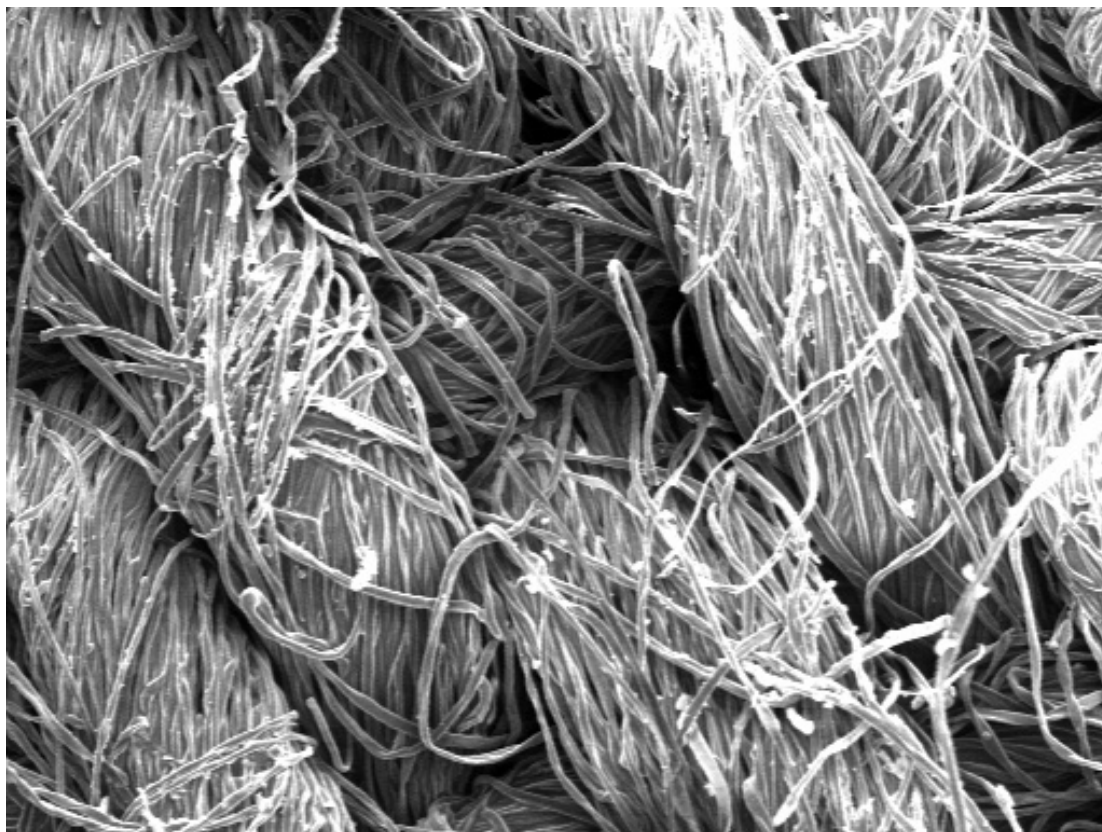

**Figure 1:** SEM microphotograph of modified cellulose material recorded on samples after the dip-coating process, magnification 80×

Secondly, the samples of modified cellulose that were functionalized with coatings and nanoparticles were investigated by Fourier Transform Infra Red spectrometer (Spectrum 100 FT-IR, Perkin Elmer) before (A) and after (B) (Figure 2 A and B) the modification with nanoparticles in order to prove that new chemical bonds were achieved. As can be seen from the Figure 2, new peaks occurred on  $1111,5\text{ cm}^{-1}$  and  $1163\text{ cm}^{-1}$ . The peaks at  $1110\text{ cm}^{-1}$  is linked to Si-O groups, (particularly Si-O-C and Si-O-Si bridges), and conversion of methoxy groups in precursor GLYMO are distinguished at  $\sim 2870\text{ cm}^{-1}$ .

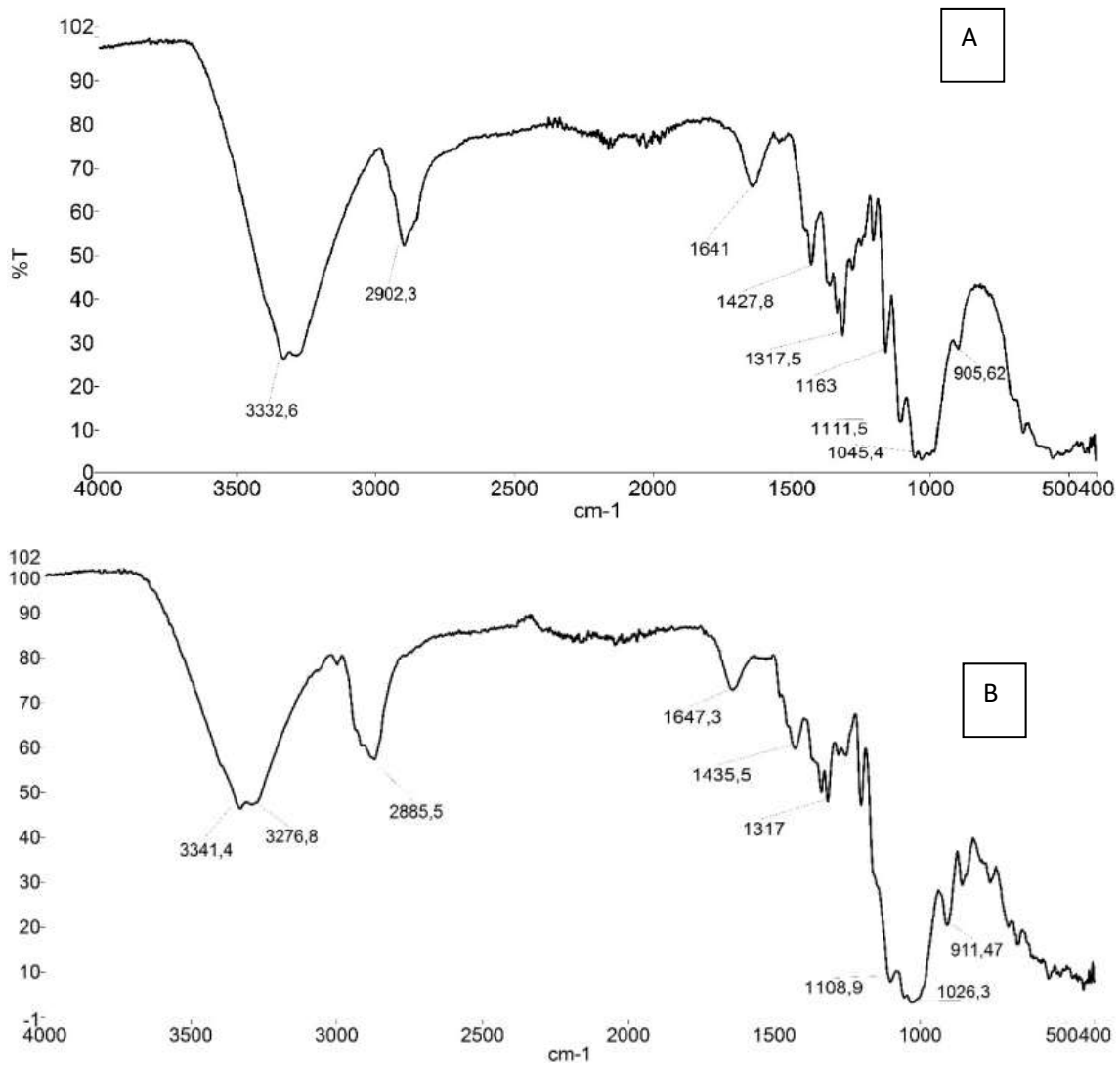

**Figure 2:** Fourier Transform Infra Red spectra of modified cotton sample after modification with nanoparticles

Investigation of antimicrobial activity was performed using a micro-dilution assay on metal and metal/oxide nanoparticles of various size, ranging from 10 to 120 nanometers (Table 5).

Table 5. Results of antimicrobial activity presented as mean  $\pm$  S. D. (N=3) of selected metal and metal/oxide nanoparticles classified according to their size

Nanoparticle size/ nm	4	10	40	100	120
MBC/ ppm	0,195 $\pm$ 0,169	0,313 $\pm$ 0,271	1,042 $\pm$ 1,263	0,137 $\pm$ 0,059	80,566 $\pm$ 0,000
MIC/ ppm	0,057 $\pm$ 0,037	0,085 $\pm$ 0,069	0,021 $\pm$ 0,017	0,026 $\pm$ 0,000	40,283 $\pm$ 0,000

The obtained results showed that the in vitro antimicrobial activity depends on the size of the nanoparticle used. The most efficient antimicrobial activity with the lowest MIC values was noticed with smaller diameters which indicate that such materials can be used on medical textiles.

The size of nanoparticles was measured by Nanoparticle Tracking Analyzer Nanosight and the results are presented in Figure 3.

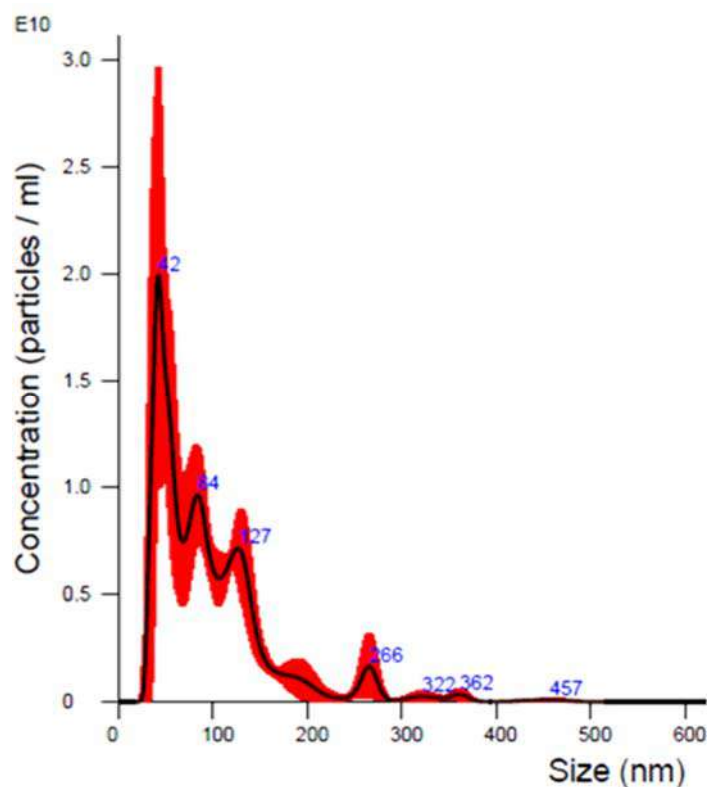

Figure 3. Results of determination of metal and metal/oxide nanoparticles size in samples determined by Nanoparticles Tracking Analyzer "Nanosight"

Those results have proved the correlation of nanoparticles to the microorganisms which are mainly important for achieving the antibacterial activity. Therefore the presence of nanoparticles on textiles is crucial for their usage in products foreseen as medical items.

## CONCLUSION

Investigation of antimicrobial effects of commercially available nanoparticles (Ag, ZnO and TiO<sub>2</sub>) on model microorganism has shown that nanoparticles have direct antibacterial effects. Therefore, such nanoparticles are widely used in textile industry for creating new materials foreseen as medical textiles, sports wardrobe and similar materials. This paper proposes methods of functionalization of cellulose with antibacterial active nanoparticles and methods of characterization of textiles. It is to be expected that such antibacterial materials will find their broad application in textile industry.

## *Acknowledgements*

The authors of this investigation are grateful for financial support to the funding of the projects: i) Project of the Adris Foundation (program Knowledge and discovery – 2018/2019), ii) Croatian Science Foundation project iii) Development of the carrier of young researchers 2017-2020 and iv) Short term financial support to the scientific research of the University of Zagreb 2018-ZUID, IP1/18

## REFERENCES

- [1] Rezić, I. Engineered Nanoparticles in Textiles and Textile Wastewaters, Analysis and Risk of Nanomaterials in Environmental and Food Samples, 59, COAC, Chennai: (2012), Elsevier, Ed. Farre, M. Barcelo, D., pp. 235-264.
- [2] Barber JD, Freestone CI. An investigation of the origin of the colour of the Lycurgus cup by analytical transmission electron microscopy. *Archaeometry*, 2018, 32(1):33–45.
- [3] Shah MA, Tokeer A. Principles of nanoscience and nanotechnology. London, Alpha Science International, Oxford, 2010, p. 10-20.
- [4] Faraday M. X. The Bakerian Lecture. —Experimental relations of gold (and other metals) to light. *Philos T R Soc Lond*, 1857, 147, 145–181.
- [5] Feenstra RM. Scanning tunneling spectroscopy. *Surf Sci*, 1994, 299–300, 965–979.
- [6] Brigger I, Dubernet C, Couvreur P. Nanoparticles in cancer therapy and diagnosis, *Adv Drug Deliver Rev*, 2002, 54(5):631–651.
- [7] Hirsch LR, Stafford RJ, Bankson JA, Sershen SR, Rivera B, Price RE, Hazle JD, Halas NJ, West JL. Nanoshell-mediated near-infrared thermal therapy of tumors under magnetic resonance guidance. *Proc Natl Acad Sci USA*, 2003, 100(23):13549–13554.
- [8] Recharla N, Riaz M, Ko S, Park S. Novel technologies to enhance solubility of food-derived bioactive compounds: A review. *J Funct Food*, 2017, (39):63–73.

- [9] Mirkin CA, Taton TA. Semiconductors meet biology. *Nature*, 2000, (40):626-27.
- [10] Radt B, Smith TA, Caruso F. Optically Addressable Nanostructured Capsules. *Adv Mater*, 2004, 16(23-24): 2184–2189.
- [11] Fresta M. Pefloxacin mesilate-loaded and ofloxacin-loaded polyethylcyanoacrylate nanoparticles characterization of the colloidal drug carrier formulation. *J Pharm Sci*, 1995, (84):895-902.
- [12] Magiorakos AP, Srinivasan A, Carey RB, Carmeli Y, Falagas ME, Giske CG, Harbarth S, et al.. Multidrug-resistant, extensively drug-resistant and pandrug-resistant bacteria: an international expert proposal for interim standard definitions for acquired resistance. *Clin Microbiol Infect*, 2012, 18(3):268–281.
- [13] Blecher K, Nasir A, Friedman A. The growing role of nanotechnology in combating infectious disease. *Virulence*, 2011, 2(5):395-401.
- [14] Huh AJ, Kwon YJ. “Nanoantibiotics”: A new paradigm for treating infectious diseases using nanomaterials in the antibiotics resistant era. *J Control Release*, 2011, 156(2):128–145.
- [15] Pelgrift R, Friedman A. Nanotechnology as a therapeutic tool to combat microbial resistance. *Adv Drug Deliver Rev*, 2013, 65(13):1803-1815.
- [16] Abramovitz I, Wisblech D, Zaltsman N, Weiss E, Beyth N. Intratubular Antibacterial Effect of Polyethyleneimine Nanoparticles: An Ex Vivo Study in Human Teeth. *J Nanomater*, 2015, (2015): 1-5.
- [17] Rezić, I. (2011), Determination of engineered nanoparticles on textiles and in textile wastewaters, *Trends in Analytical Chemistry*, 30, pp. 1159–1167.
- [18] Li, X., Xu, H., Chen, Z. S. and Chen, G., (2011), Biosynthesis of Nanoparticles by Microorganisms and Their Applications, *Journal of Nanomaterials*, 2011, pp. 1 – 16.
- [19] Chen, L., Shen, Y., Xie, A., Huang, B., Jia, R., Guo, R. and Tang, W., (2009), Bacteria-Mediated Synthesis of Metal Carbonate Minerals with Unusual Morphologies and Structures, *Crystal Growth and Design*, 9, pp. 743–754.

# EVALUATION OF A PROMISING BOTANICAL REPELLENT ON HORSES AND PERSPECTIVES AS STRATEGY TO LOWER THE RISK OF EQUINE WNV FOR LOWERING THE PEDICULOSIS RISK AT SCHOOLS IN IRAN

**Asghar TALBALAGHI<sup>1,2</sup>, Sahar HASSANDOUST<sup>3</sup>, Arshad ALI<sup>4\*</sup>**

<sup>1</sup>Freelance Entomologist, Mosquito Control Operations - Citta di Alessandria, Alessandria, Italy, \*email: talbalaghi@libero.it

<sup>2</sup>Italian Mosquito Control Association

<sup>3</sup>Public Health Officer of Iran University of Medical Science, Shahriar Health Network, Iran

<sup>4</sup>Emeritus Professor, University of Florida, Mid-Florida Research and Education Center, Apopka, Florida, USA

---

## ABSTRACT

*Repel Care<sup>®</sup>, a botanical mosquito repellent, containing primarily turmeric and eucalyptus oils, was evaluated topically at 6.9 and 3.4 grams/ m<sup>2</sup> surface area on sports horses to repel mosquitoes (mainly *Ochlerotatus caspius* and *Culex spp*) in a stable situated amid a rice field area in Alessandria, south Piedmont, Italy. The repellent gave satisfactory results with an overall average repellence of 62.3% (range 29.1 to 88.4%) during the four evenings of evaluation. Higher rates of the repellent may produce better results in terms of magnitude and persistence.*

## KEYWORDS

*Mosquito repellent, horses, persistency*

---

## INTRODUCTION

In Italy, vast areas of wetlands in Piedmont, northern Italy (Figure 1), exist during most part of the year as a result of rice cultivation. It is estimated that nearly 100.000 ha of irrigated rice fields prevail annually in the Province of Alessandria [1]. These rice fields provide ideal habitats for the breeding of several mosquito species, and particularly several generations of *Ochlerotatus caspius* each year. This species is a ferocious biter and is capable of dispersing over vast areas from the breeding source; wind carried *Oc. Caspius* can migrate up to 30 km or more from the breeding source [2].



Figure 1. Province of Alessandria

Besides humans, numerous animals including horses with relatively large bodies suffer from mosquito bites and transmission of diseases. In many situations, the horse stables are nestled in territories heavily infested with mosquitoes; these stables are both open door and covered where the adult mosquitoes often have free access. Mosquito control at present in and around the stables is primarily based on the use of organic adulticides and synthetic repellents. These measures often do not result in satisfactory control of mosquitoes and also are environmentally unacceptable due to their adverse effects. Natural botanical repellents provide ideal alternatives as these products have minimal adverse impact on the environment and the host animal [3].

We tested the mosquito repellent activity of the botanical repellent, Repel Care<sup>®</sup>, against horses (expensive thoroughbred breed) in a stable in Alessandria (Figure 2), south Piedmont, where the owners of the horses were nervous and greatly concerned about the discomfort and restlessness of their horses due to tremendous mosquito bites. In this situation, mosquito adulticiding and continued use of synthetic chemical repellents have failed to produce satisfactory results.



Figure 2. Horses stable

## MATERIALS AND METHODS

The test repellent, Repel Care<sup>®</sup>, was a product of Thailand. The repellent contained 38% natural active ingredients (essentially turmeric and eucalyptus oils) and had a pleasant aroma.

Four horses (Figure 3), of the same age and body size (each horse head, neck, and total body surface area approximately 3 m<sup>2</sup>) were selected for this evaluation. These horses were generally of the same color (brownish) and were sports (race) horses (European Equestrian International Champions).

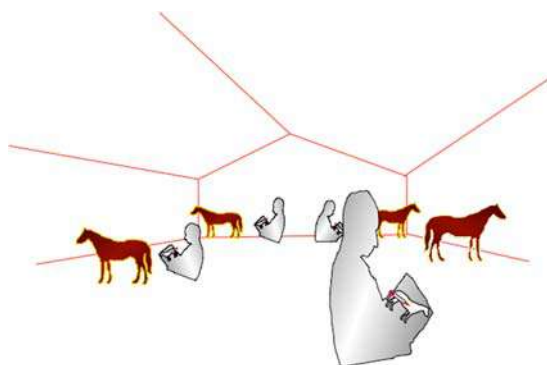

Figure 3. Tested horses

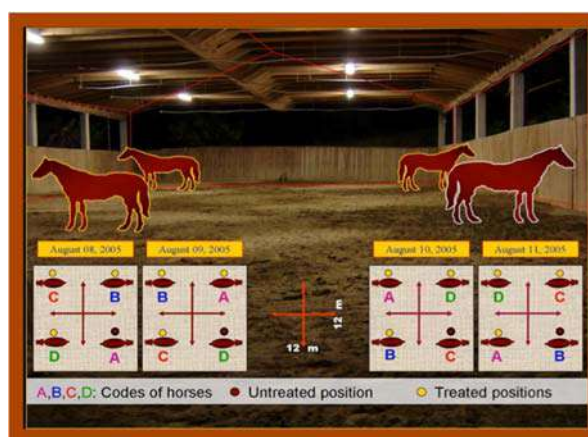

Figure 4. Conditions of evaluation conduction

The evaluation was conducted for four (Figure 4) consecutive evenings between 2000 and 2400 hours (five hours) for the first evening and thereafter between 2000 and 100 hours (six hours) during summer 2005. Each evening, the repellent was applied topically on the entire head, neck and body of three horses, while the fourth horse was not treated with the repellent and served as a control. For an even coverage of the repellent on the entire horse, the required amount of the repellent (6.9 grams/m<sup>2</sup>) was mixed with known amount of absolute alcohol and applied evenly on the horse.

During the first treatment, a spray bottle was used to apply the repellent but due to the unexpected movements of the horse, the distribution of the repellent on the horse was suspected uneven. Therefore, the latter three treatments were gradually applied with a piece of cloth making sure of the coverage and a uniform distribution of the repellent on each treatment horse. The control horse received absolute alcohol only. The rate of 6.9 grams/m<sup>2</sup> (the recommended rate for human skin) [4] was evaluated on first three evenings and on the fourth evening a rate of 3.4 grams/m<sup>2</sup> was utilized. The four horses were maintained tied under a shed in fixed positions during each evaluation period and any two horses were nearly 12 m apart from each other.

To monitor the number of mosquitoes landing and biting on each horse after the treatment, one technician was assigned to each horse for counting mosquitoes for a total of 10 minutes (5 minutes



on each side of the horse) each hour during the five or six hours of observation. During this observation, the number of mosquitoes on face, neck, different parts of the body, and legs of each horse were also noted. Every evening the location of horses was rotated so that each horse occupied all locations at least once.

Adult mosquito repellence was calculated by using the following formula of Mulla suggested by Reison 2004, [5]

$$R = [(C-T)/C] 100 \quad (1)$$

where “C” is the total number of mosquitoes biting the control horse; and “T” the total number of mosquitoes biting the repellent-treated horse.

In order to assess the prevalence of adult mosquitoes near the experimental area, two CO<sub>2</sub> baited traps were placed 50 meters from the experimental area and monitored hourly (during repellent evaluation time) for the collected mosquitoes.

## RESULTS

Adult mosquito repellence from horses during the first three evenings of the repellent evaluation at 6.9 grams/m<sup>2</sup> ranged from a mean value of 29.1% (first evening) to 88.4% (second evening), with an overall average of 62.3% repellence during the first three evenings of evaluation. In the fourth evening, at 3.4 grams/m<sup>2</sup>, the mean repellence amounted to 59% (Figure 5). Generally, the repellent activity was the greatest during the second and third evenings of evaluation. During each evening, the number of mosquitoes in the controls was consistently higher at least during the first four hours of evaluation on each evening (Figure 6).

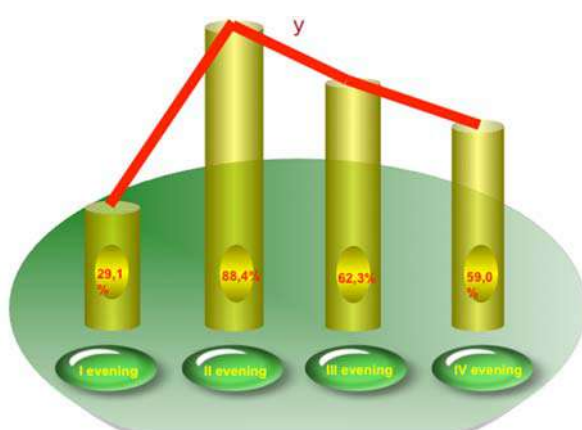

Figure 5. Repellence amounts

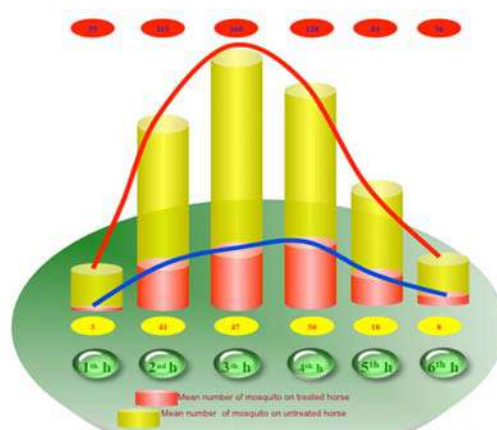

Figure 6. Persistency

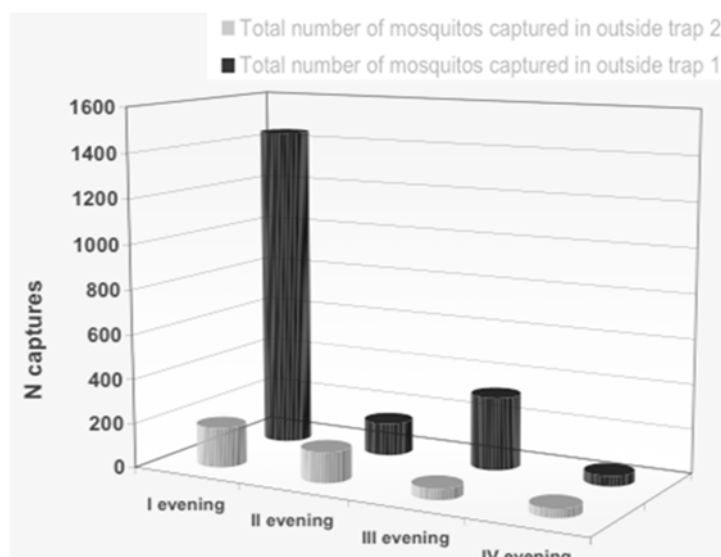

Figure 7. No. of mosquitos in trap

The data concerning CO<sub>2</sub> traps varied widely during the different evenings but generally the number of adult mosquitoes captured during the second and third hours of evaluation on any occasion was greater than the other hours of observation (Figure 7).

## CONCLUSIONS

This preliminary evaluation of Repel Care® shows the effectiveness of this botanical mosquito repellent against horses. The owners of the horses were satisfied with the results although complete repellence was not achieved at the rates of the repellent use in this study. Because of the densely hairy bodies of this animal, higher rates of the repellent on horses may be required for better results. Considering the safety features associated with botanical repellents (compared to chemical adulticiding, or use of chemical repellents), further studies to fine tune the effective rates of this repellent on horses as well as standardization of repellent application method for its uniform distribution are suggested.

## Open question

Considering the technological development associated with the textile industry, which use the potential of nanotechnology, they can widen the use of this repellent and lengthen the current performance. Use of impregnated covers for horses to contain the risk of equine cases of WNV, potential for lowering the extent of Pediculosis that must be implemented and measured effectiveness

### **Acknowledgments**

We express our gratitude to CB QUARTER HORSE TRAINING SCHOOL of Barbara Cuniolo, Adriana Arobba and Claudia Pastore, the owners and trainers of horses: "CLASSICAL JUSTICE", "CODY BENITO BAR", "HOT AS I WANNA BE" and "LIL SMART PEPPY". We are grateful for hard work of, Fabio Fossati, Moritz Bitzhenner. We are grateful to Thai people, Chanon R., Nackanun C., Apiwat T. and Usavadee T. for the invention and the production of Active Ingredient.

### **REFERENCES**

- [1] Talbalaghi A.: Mosquito control in southern Alexandria's province of Piedmont, Proc. 13th European SOVE meeting, Proceeding of the International Symposium on Mosquitoes in Rice elds, organized by EMCA and University of Eastern Piedmont, 79, 2000.
- [2] Talbalaghi A. et al.: Rice cultivation and mosquito development in Piedmont (Italy), Proceeding 2nd EMCA Workshop- Bologna, 28-29, 2002.
- [3] Tawatsin A., Asavadachannukorn P., Thavara U.: Repellency of essential oils extracted from plants in Thailand against four mosquito vectors (Diptera: Culicidae) and oviposition deterrent effects against *Aedes aegypti*, *Southeast Asian J Trop Med Public Health*, 37, 2006.
- [4] Barnard D.R., Bernier U., Xue R.D., Debboun M.: Standards Methods for Testing Mosquito Repellents, American Society for Testing Materials Method, 103, 2000.
- [5] Reisen W.K.: University of California, Center for Vectorborne Diseases, Department of Pathology, Microbiology and Immunology, School of Veterinary - *Vector Biology, Ecology and Control*, 127-137, 2004.

# ENERGY SAVINGS IN SHOE SOLE PRODUCTION PROCESS

Ivana ŠPELIĆ<sup>1\*</sup>, Alka MIHELIĆ – BOGDANIĆ<sup>1</sup>, Rajka BUDIN<sup>2</sup>

<sup>1\*</sup>University of Zagreb, Faculty of Textile Technology, Prilaz baruna Filipovića 28a, 10000 Zagreb, Croatia,

\*email: ispelic@ttf.hr

<sup>2</sup>University of Zagreb, Faculty of Chemical Engineering and Technology, Marulićev trg 19, 10000 Zagreb, Croatia

---

## ABSTRACT

*The synthetic rubbers production started in World War II and today synthetic rubber accounts for the majority of rubber production. Energy savings in rubber processing plants are of great importance since the thermosets and elastomers (rubbers) encompasses around 30% of the tonnage of all synthetic polymers produced. Today, the synthetic rubbers exceed the tonnage of natural rubber.*

*There are several industries involved in the rubber processing, but one of the main rubber processing industry is the shoe sole production. The shoe soles are usually made from synthetic polymers such as Polyisoprene (IR), Thermoplastic Polyurethane (TPU), Polyurethane foams or Ethylene Vinyl Acetate (EVA), which all fall in the scope of synthetic rubbers. Ethylene vinyl acetate (also known as EVA) is the copolymer of ethylene and vinyl acetate. This paper analyses the potential of energy savings in shoe soles production process made of Ethylene Vinyl Acetate (EVA), since these are the most popular soles currently. EVA shoe soles are known for their excellent properties. They are lightweight, easy to mould, have good water and moisture resistance, high elasticity, great shock absorption, great thermal insulation properties, high durability, low-temperature toughness, stress-crack resistance and great resistance to UV radiation.*

*The energy savings using the process return condensate in shoe sole production process are presented. Using the return condensate results in lower make up water consumption, substantial fuel savings needed to produce steam and lower chemical consumption. Returning hot process condensate to the boiler results in oil savings of 14,9%. Also, the thermal pollution is reduced by 95,3%, while the volume of the flue gases is lowered from 17,11 m<sup>3</sup><sub>FG</sub>/kg<sub>NEC</sub> to 14,57 m<sup>3</sup><sub>FG</sub>/kg<sub>NEC</sub> or by 14,8%. Such a system enables both the oil savings and reduces the thermal pollution.*

## KEYWORDS

*energy savings; return condensate; shoe sole production, Ethylene Vinyl Acetate (EVA), thermal pollution reduction*

---

## INTRODUCTION

There are several industries involved in the production and processing of rubber, but today most of the rubber used is classified as synthetic rubber, which is produced by the petrochemical industry in processor (fabricator) plants. Many foamed rubber parts, such as shoe soles, are produced by molding [1].

The shoe soles or outsoles are the bottom part of the shoes in direct contact with the floor. Nowadays they are usually made from synthetic polymers such as Polyisoprene (IR), Thermoplastic Polyurethane (TPU), Polyurethane foams, Ethylene Vinyl Acetate (EVA) or Polyvinylchloride (PVC). Synthetic polymers are made from various petroleum-based monomers and the polymers have become the main specialized materials for footwear industry [2].

The most popular soles currently are Ethylene Vinyl Acetate (EVA) soles. Ethylene Vinyl Acetate is polymer based copolymer consisting of ethylene and vinyl acetate. EVA is also known as expanded rubber or foam rubber. The material is known to be lightweight and easy to mould. Other popular properties involve good water and moisture resistance, high elasticity, great shock absorption, great thermal insulation properties, durability, low-temperature toughness, stress-crack resistance, hot-melt adhesive water proof properties and resistance to UV radiation [3]. Soles made from Ethylene vinyl acetate (EVA) are known for their softness and flexibility. They are processed like other thermoplastics materials. EVA has little or no odour and is competitive with rubber and vinyl products in many electrical applications. [4].

### **SHOE SOLES INJECTION MOLDING PROCESS**

Principal molding processes for rubber are [1]:

1. compression molding,
2. transfer molding, and
3. injection molding.

There are two basic ways to mold the EVA soles. First one is the compression molded EVA (CMEVA) is made by filling a mold with EVA pellets to achieve desired shape or by compressing a block of EVA foam inside a metal mold. The heat and pressure are applied to the mold, causing the pellets to melt or causing the EVA foam to expand and fill the mold cavity. The second one is the injection molding process. Direct injection is the process of forcing a heated thermoplastics polymer of a highly plastic state under high pressure into the cavity of a mold to achieve desired shape. The process produces discrete components that are almost always net shape. The production cycle time is typically in the range of 10 to 30 sec [1]. When the material solidifies in the mold it takes the desired shape and is removed from the mold. The injection molding is quite popular due to zero wastage as the exact amount of EVA is required. A single cavity or multiple cavities moulds are generally made of tools steel, aluminium or stainless steel [5]. The injection molding is economical only for large production quantities. With injection molding of rubber, there are risks of premature curing. Advantages of injection molding include better dimensional control, less scrap and shorter cycle times. Because of high mold costs, large production quantities are required to justify injection molding [1].

An injection molding machine consists of, Figure 1:

1. the plastic injection unit (similar to the extruder) and
2. the mold clamping unit (power press).

The plastic injection unit consists of a barrel that is fed by a hopper containing a supply of plastic pellets. Inside the barrel is a reciprocating, which turns and heats the polymer, and also injects the molten plastic into the mold. The mold clamping unit holds the two platens, affixed and a moveable platen, in proper alignment with each other, keeps the mold closed during injection by applying a clamping force sufficient to resist the injection force and opens and close the mold [1].

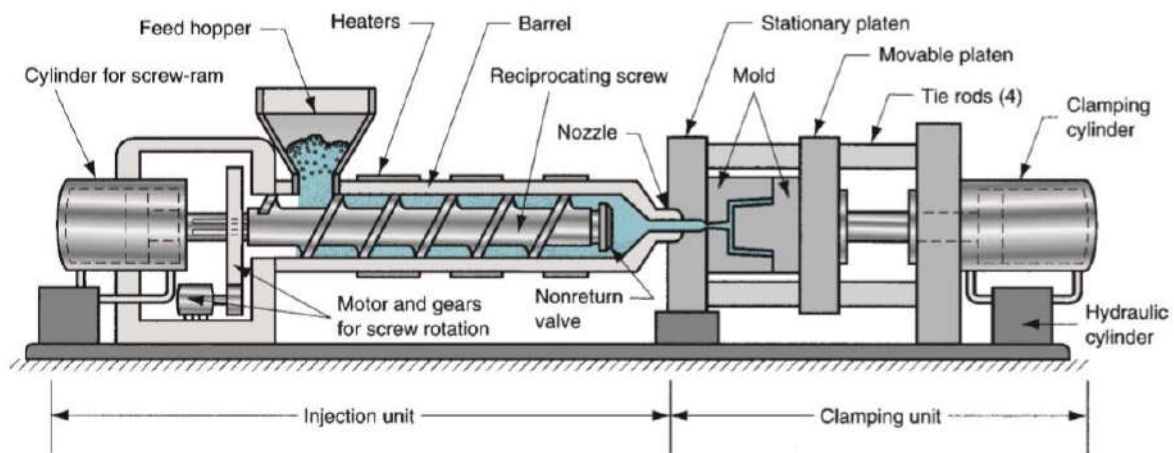

Figure 1. The injection molding machine

The EVA mixed compound is taken to an injector that can be rotating or multi-station since the average injection cycle of each mold is around 7 minutes, so with a multi-station machine you can achieve a faster and more efficient production [6].

The steps of the EVA injection process [6]:

- (a) The mixture is added to the injector storage tank.
- (b) The injection volume is calculated and adjusted according to the mold.
- (c) The material is heated to 95 °C and injected into the mold at a pressure of ~1200bar.
- (d) The mold is heated to 170 °C to activate the expander and also the crosslinking agents
- (e) The mold is kept closed at 170 °C until the crosslinks are fully completed, about 1.5min / mm thick.
- (f) The mold is opened, and the EVA sole jumps out of the cavity rapidly and begins to expand.

The technical description for the selected Automatic Eva Foam Injection Molding Machine and the yearly energy analysis is shown in Table 1.

Table 1. The Technical Description for Automatic Eva Foam Injection Molding Machine

Technical Description	
Work Stations	6
Clamping Force (kg)	170000-230000
Mould-Opening Stroke (mm)	350
Standard Thickness of Mould (mm)	100-210-230
Mould Plate Size (mm)	2(290*550)
Height of Injection Nozzle (mm)	60
Method of Heating	electric
Heating Power (kw)	8.04
Injection System	
Injectors (set)	2
Diameter of Screw (mm)	60/70
L/D Ratio of Screw	23
Max Injection Capacity (cc)	920-1100
Injection Pressure	1100
Injection Speed (cm/sec)	10
Rotating Speed of Screw (r.p.m)	0-190
Temperature Control (section)	4
Electricity Consumption	
Heater Barrel (kw)	12.1
Motor for Injector Moving (kw)	1.5
Heating Board of Mould (kw)	76.8
Hydraulic System (kw)(50hz)	40.5
Vacuum Pump (kw)	2.2
Cooling Fan of Barrel (HP)	1
Total Electricity (kw)	50/70/150
Oil Tank Size (L)	1000
Machine Weight (kg)	23800
Machine size (m)	6.5*4.5*2.8
Output (Pairs/day)	5000
Working times (h/day)	8
Monthly working times (days/month)	25

## INPUT DATA AND ENERGY ANALYSIS OF TECHNOLOGICAL PROCESS

The energy consumption in shoe sole process manufacturing at rate  $n=2500$  per shift (or 5000 pairs per day or 625 pairs per hour), is carried out. This technology (Fig. 2) includes processes in mixer, warming mill, calender, cutter, extruder, cooler etc. The plant works 8 hours in day, 25 days in month or  $\tau=2400$  hours yearly, i.e. so the plant use factor becomes  $\beta=27, 4\%$ . Such a basic process needs electrical energy in amount of  $e_{el}=3,44 \text{ kWh}_e/n/\text{kg}$  product and dry saturated steam (13 bar) in mass of

$d_s=14,870$  kg<sub>s</sub>/kg product. The process uses also water in mass of  $d_w=4,57$  kg<sub>w</sub>/kg product [7]. Dry saturated steam is produced in an oil fuelled boiler with efficiency  $\eta_B=80\%$ .

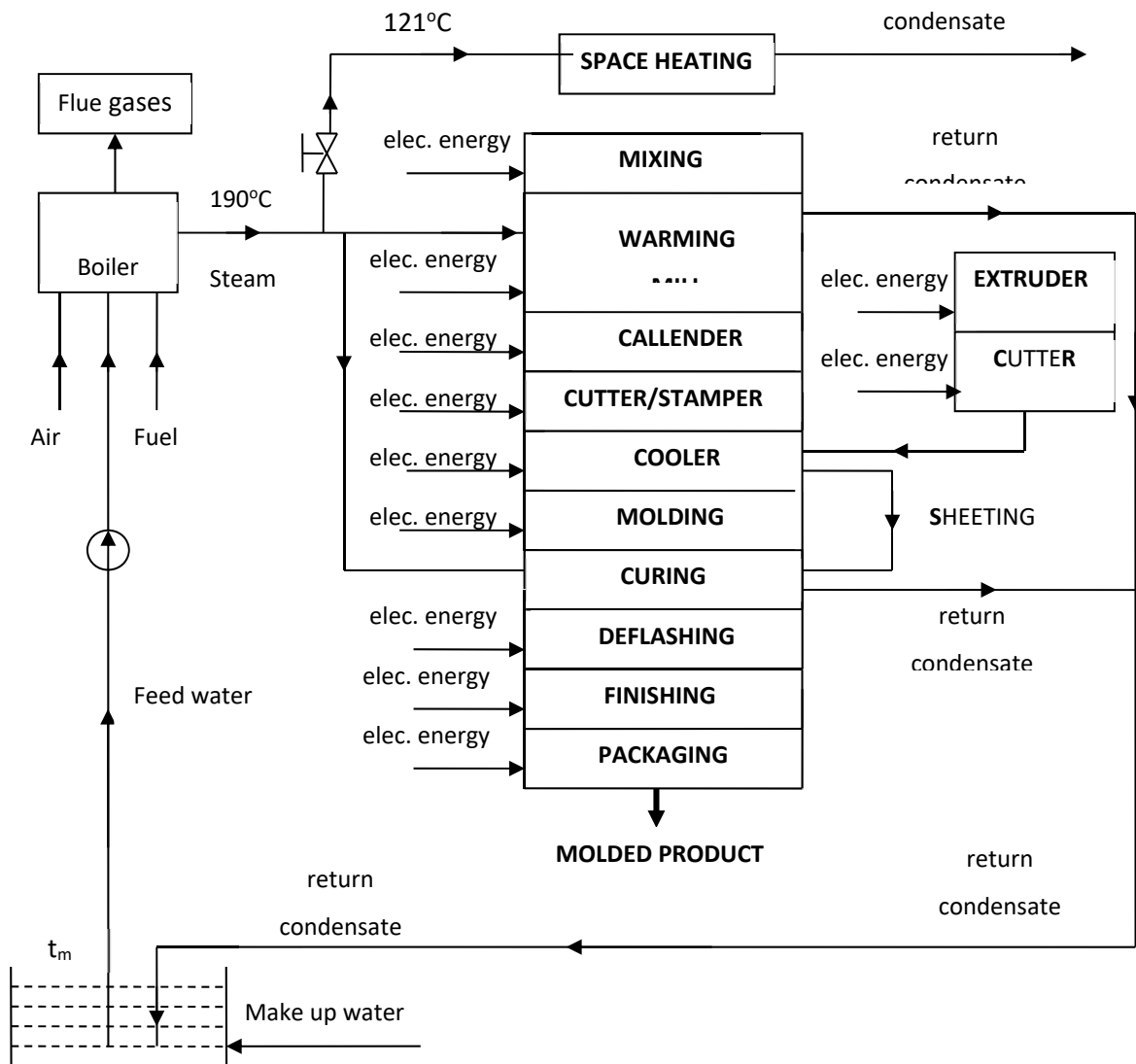

Figure 2. Shoe sole process flow diagram

The percentage composition of oil by mass is: C:H:N:S = 85,3%:11,6%: 0,6% :2,5% and is burned with excess air coefficient  $\alpha=1,25$ . A part of saturated steam  $d_{SP}=14,170$  kg<sub>s</sub>/kg<sub>P</sub> is used for industrial process and the rest  $d_{SH}=0,7$  kg<sub>s</sub>/kg<sub>H</sub> for space heating. The lower heating value of oil is  $H_L = 41268$  kJ/kg [7]. Feed water enters the boiler with temperature  $t_b=25^\circ\text{C}$  and the whole condensate with temperature  $t_c=121^\circ\text{C}$  is withdrawn to the to the surrounding. The air required for oil combustion passes into firebox with temperature  $t_a= 25^\circ\text{C}$ , while the temperature of exhaust stacks is  $t_{FG}=221^\circ\text{C}$ .

The heat transferred to the steam generator is:

$$q_s=d_s(h_s-h_b)=14,870(2785-104,68) = 39856,36 \text{ kJ/kg}_P,$$



where  $h_s$  and  $h_b$  are the steam and water enthalpies taken from thermodynamically tables [8].

From this data the unit mass of oil requirement using heat balance is:

$$d_F = q_s / H_L \times \eta_B = 39856,36 / 41268 \times 0,80 = 1,21 \text{ kg}_F / \text{kg}_P.$$

The specific steam consumption is:

$$d_{SP} = d_s / d_F = 14,870 / 1,21 = \text{kg}_s / \text{kg}_F,$$

or the oil consumption becomes:

$$d_{SF} = d_F / d_s = 1,21 / 14,870 = 0,0814 \text{ kg}_F / \text{kg}_s.$$

Taking into consideration yearly operating time  $\tau = 2400$  hours and shoe sole rate  $n = 625$  pairs, oil consumption is:

$$D_{FY} = d_F \times \tau \times n = 1,21 \times 2400 \times 625 = 1,815 \times 10^6 \text{ kg}_F.$$

The total condensate  $d_c$  from the process  $d_{CP} = 14,170 \text{ kg}_C / \text{kg}_P$  and from the space heating  $d_{CH} = 0,7 \text{ kg}_C / \text{kg}_H$  with temperature  $t_c = 121^\circ\text{C}$  is withdrawn to the surrounding (Fig. 3).

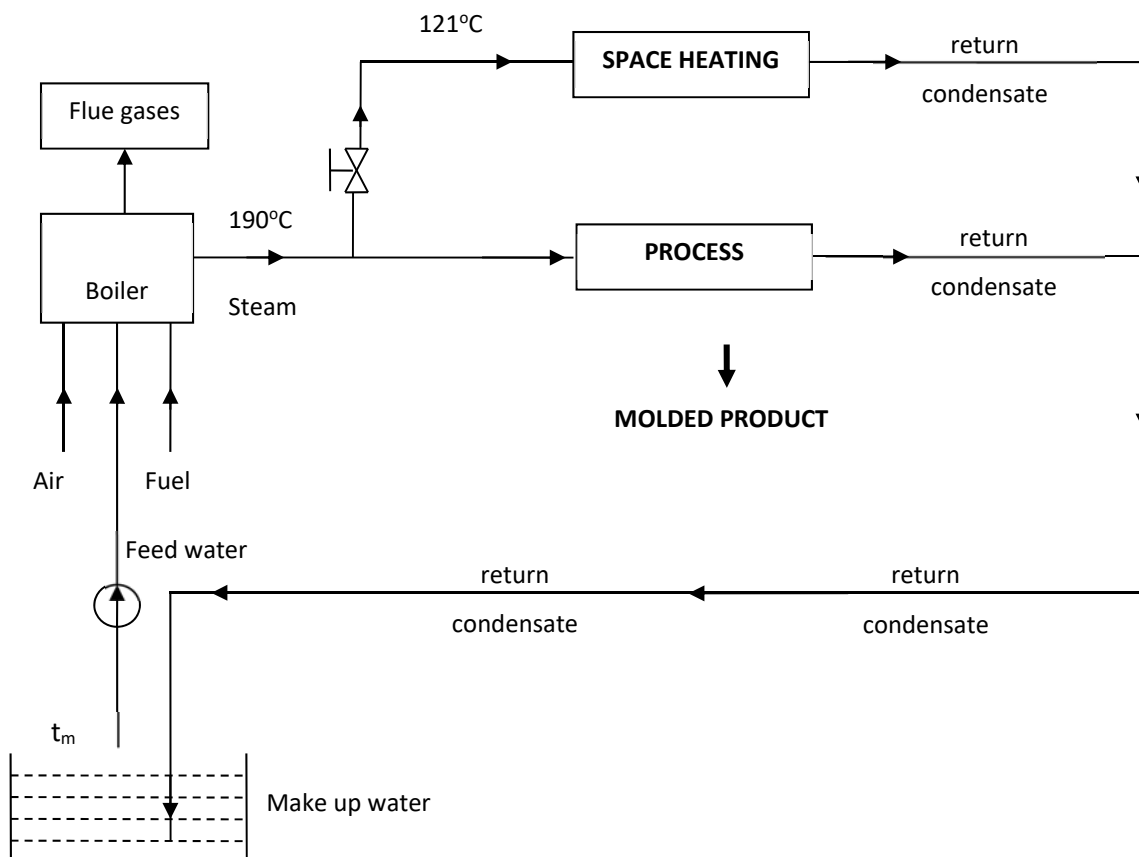

Figure 3. Returning hot process condensate

The heat of the condensate is:

$$q_c = (d_{CP} + d_{CH})h_{121}^0 = (14,170 + 0,7) 507 = 7539,1 \text{ kJ/kg}_P.$$

To improve process efficiency [9], the waste condensate could be applicate for feed water preheating.

## ANALYSES OF COMBUSTION PRODUCTS

The products of fuel combustion are mostly gaseous [9]. For complete oil combustion, 25% air is supplied. The minimum oxygen volume  $V_{O_2 \text{ min}}$  and stehiometric air volume  $V_a$  required for combustion is expressed as:

$$V_{O_2 \text{ min}} = (22,4/12) \{C + 3[H - (O - S)/8]\} = 2,26 \text{ m}^3_{O_2}/\text{kg}_F$$

$$V_a = V_{O_2 \text{ min}}/0,21 = 10,8 \text{ m}^3_a/\text{kg}_F.$$

To make safe the complete combustion of oil the excess coefficient of  $\alpha = 1,25$  was taken.

The actual volume of air is:

$$V_{a\alpha} = V_a \times \alpha = 10,8 \times 1,25 = 13,5 \text{ m}^3_a/\text{kg}_F.$$

The total volume of wet flue gases  $V_{FG}$  consists of carbon dioxide, sulphur dioxide, nitrogen, excess oxygen and water vapour:

$$V_{FG} = V_{CO_2} + V_{SO_2} + V_{N_2} + V_{O_2} + V_{H_2O}.$$

Volume of each gas component is calculated using following expressions:

$$V_{CO_2} = (22,4/12)C = (22,4/12)0,853 = 1,592 \text{ m}^3_{CO_2}/\text{kg}_F$$

$$V_{SO_2} = (22,4/32)S = (22,4/32)0,025 = 0,0175 \text{ m}^3_{SO_2}/\text{kg}_F$$

$$V_{N_2} = (22,4/28)S + 0,79 \times V_{a\alpha} = (22,4/28)0,006 + 0,79 \times 13,5 = 10,67 \text{ m}^3_{N_2}/\text{kg}_F$$

$$V_{O_2} = 0,21(\alpha - 1)V_a = 0,21(1,25 - 1)10,8 = 0,567 \text{ m}^3_{O_2}/\text{kg}_F$$

$$V_{H_2O} = (22,4/2)H + (22,4/18)W = (22,4/2)0,116 + (22,4/18)0 = 1,299 \text{ m}^3_{H_2O}/\text{kg}_F$$

and the whole volume of exhaust gases with excess air is:

$$V_{FG} = 14,1455 \text{ m}^3_{FG}/\text{kg}_F$$

The proportional of each constituent expressed as a percentage of the total wet product is:

$$CO_2 : 11,25\%; SO_2 : 0,12\%; N_2 : 75,43\%; O_2 : 4,02\%; H_2O : 9,18\%.$$

The specific heat of exhaust gases with temperature  $t_{FG} = 221^\circ\text{C}$  and the percentage by volume of products as well as the specific heat of each gas, should be obtained [10]:

$$c_{p \text{ FG}} = c_p CO_2 \times \%V_{CO_2} + c_p SO_2 \times \%V_{SO_2} + c_p N_2 \times \%V_{N_2} + c_p O_2 \times \%V_{O_2} + c_p H_2O \times \%V_{H_2O} = 1,392 \text{ kJ/m}^3 \text{ grad}.$$

The energy released on the complete combustion per unit mass of the fuel or per unit of products depends on total flue gases volume, specific heat and flue gases temperature:

$$q_{FG} = V_{FG} \times C_{p,FG} \times t_{FG} = 14,1455 \times 1,392 \times 221 = 4351,61 \text{ kJ}_{FG}/\text{kg}_F,$$

$$q_{FG,P} = q_{FG} \times d_F = 4351,61 \times 1,21 = 5265 \text{ kJ}_{FG}/\text{kg}_P.$$

The volume of exhaust gases per unit of product rejected to the surrounding with temperature  $t_{FG} = 221^\circ\text{C}$  is:

$$V_{FG,P} = V_{FG} \times d_F = 14,1455 \times 1,21 = 17,11 \text{ m}^3_{FG}/\text{kg}_P.$$

### PROCESS CONDENSATE HEAT RECOVERY

The returning hot condensate to the boiler has many several reasons. Using return process condensate to heat feed water less amount of make-up water is required, less oil is needed to produce steam from hot water rather than cold water. Return of high purity condensate i.e. distilled water reduces also chemicals and treatment cost as well as energy losses due to the boiler blowdown [8]. In analysed procedure the process condensate in amount of  $d_{CR} = 14,170 \text{ kg}_C/\text{kg}_P$  with temperature  $t_C = 121^\circ\text{C}$  is returned and mixed with the make-up water in mass  $d_W = 0,700 \text{ kg}_W/\text{kg}_P$  with temperature  $t_W = 25^\circ\text{C}$ .

Considering the adiabatic mixing process, the feed water will enter the boiler with temperature:

$$t_m = (d_{CR} \times t_C + d_W t_W) / d_S = (14,170 \times 121 + 0,700 \times 25) / 14,870 = 116,48^\circ\text{C}.$$

The oil consumption is after heat balance:

$$d_{FC} = d_S (h_S - h_m) / H_L \times \eta_B = 14,870 (2785 - 492) / 41268 \times 0,8 = 1,03 \text{ kg}_F/\text{kg}_P.$$

The specific steam consumption is:

$$d_{SP,C} = d_S / d_{FC} = 14,870 / 1,03 = 14,44 \text{ kg}_S/\text{kg}_P.$$

Yearly consumption is:

$$D_{FC,Y} = d_F \times \tau \times n = 1,03 \times 2400 \times 625 = 1,545 \times 10^6 \text{ kg}_F.$$

Heat condensate for feed water preheating is:

$$Q_C = d_C \times h_{121}^0 = 14,170 \times 507 = 7184,19 \text{ kJ}_C/\text{kg}_P.$$

The application of return condensate with process without condensate heat recovery shows oil savings of:

$$S=(d_F-d_{FC})/d_F=(1,21-1,03)/1,21= 0,1487 \text{ i.e. } 14,9\%.$$

The condensate heat, which is discharged to the surrounding becomes:

$$q_{CH}=d_{CH}\times h_{121}^0=0,7\times 507= 354,9 \text{ kJ/kg}_P.$$

So, the thermal pollution is decreased from 7539,1 kJ/kg<sub>P</sub> to 354,9 kJ/kg<sub>P</sub> or for 95,3%.

In this analyses case the flue gases volume per unit of product that is rejected to the atmosphere with temperature  $t_{FG}=221^{\circ}\text{C}$  is:

$$V_{FGC}=V_{FG}\times d_{FC}=14,1455\times 1,03= 14,57 \text{ m}^3_{FG}/\text{kg}_P.$$

The volume of exhaust gases is lowered from 17,11 m<sup>3</sup><sub>FG</sub>/kg<sub>P</sub> to 14,57 m<sup>3</sup><sub>FG</sub>/kg<sub>P</sub> or for 14,8 %.

## CONCLUSIONS

Since the synthetic rubbers accounts for the majority of rubber production, the energy savings are of great importance. One of the main products in the area of the synthetic rubbers production are the shoe soles made from Ethylene Vinyl Acetate (EVA). This paper analyses the potential of energy savings using the process return condensate in EVA shoe soles production process. The energy savings are seen through lower make up water consumption, substantial fuel savings and lower chemical consumption. Returning hot process condensate to the boiler results in oil savings of 14,9%, the thermal pollution is reduced by 95,3%, while the volume of the flue gases is lowered from 17,11 m<sup>3</sup><sub>FG</sub>/kg<sub>NEC</sub> to 14,57 m<sup>3</sup><sub>FG</sub>/kg<sub>NEC</sub> or by 14,8%.

## Acknowledgements

This paper is funded by project HRZZ IP-06-2016 5278: Comfort and antimicrobial properties of textiles and footwear (ComforMicrobTexFoot).

## REFERENCES

- [1] M. P. Groover, Fundamentals of Modern Manufacturing: Materials, Processes, and Systems, 4<sup>th</sup> edition, John Wiley & Sons Inc, 2010.
- [2] R. M. Karkalića, Jo. R. Radulović, D. B. Jovanović, Characteristics of polyurethane and elastomer parts for shoe industry produced by liquid injection molding technology, <http://dx.doi.org/10.5937/vojtehg65-10543>.

- [3] Y.-R. Jeng, D.-S. Liu and H.-T. Yau, Designing Experimental Methods to Predict the Expansion Ratio of EVA Foam Material and Using Finite Element Simulation to Estimate the Shoe Expansion Shape, *Materials Transactions*, Vol. 53, No. 9 (2012) pp. 1685 to 1688.
- [4] O. H. Nautiyal, Molding of EVA Soles Using Expanding and Reducing Agents, *International Journal of Engineering Science and Technology (IJEST)*, Vol. 4 No.07, 2012, pp. 3050-3058.
- [5] L. C. López, Polymer injection moulding for shoe soles production, M.Sc. Thesis, Vilnius Gediminas technical university faculty of mechanics, 2014.
- [6] E. J. Ferreir, M. M. Dias, E. L. Schneider. Analysis of Non-Uniform Expansion Behavior of Injected EVA. *Academ J Polym Sci*. 2018; 1(4): 555569.
- [7] I. Sutlović, A. Mihelić-Bogdanić, R. Budin. Waste Heat Utilization in Garment Industry, *Annals of DAAAM for 2001 and Proceeding of 12th International DAAAM Symposium "Intelligent Manufacturing & Automation: Focus on Precision Engineering"*, Katalinić, Branko (ur.), Beč: DAAAM International, 2001. pp. 469-470
- [8] A. Mihelić-Bogdanić, R. Budin. Investigation on energy conservation in thermoplastics production, *Energy conversion and management*, 49 (2008), 8; 2200-2206 doi:10.1016/j.enconman.2008.01.028
- [9] T. D. Eastop, A. McConkey. *Applied Thermodynamics for Engineering Technologists*. 5<sup>th</sup> ed. New York: Longman Scientific & Technical, John Wiley & Sons, (1994)
- [10] F. Bošnjaković. *Technische Thermodynamik*. Dresden: Verlag T. Verlag T. Steinkopff (1971)

Design, fashion trends  
& marketing

**TZG**

# IMPLEMENTATION OF MODEL FOR DESIGNING AFFILIATED CLOTHING WITH LOCAL IDENTITY

**Jana VILMAN PROJE<sup>1</sup>, Matejka BIZJAK<sup>2\*</sup>**

<sup>1</sup>FOLKLORDIZAJN, Jana Vilman Proje,s.p., Stara Fužina 134, 4265 Bohinjsko jezero, SI-Slovene

<sup>2\*</sup>University of Ljubljana, NTF Department of Textiles, Graphic Arts and design, Snežniška ulica 5, 1000 Ljubljana, SI-Slovene, email: mateja.bizjak@ntf.uni-lj.si

---

## ABSTRACT

*In tourism is the first impression of essential meaning as tourists falling by what they see. Working or official clothes for the tourism sector should take into account that clothing is a reflection of the represented or advertised area. Therefore, clothing of the representatives must be consistent with the clothing habits in the region and they must correspond to the heritage and the style of the geographical area.*

*The analysis of clothing practices in tourism and for tourism in Slovenia has shown that most tourism employees wear their own clothes. On the basis of a case study and active research through design, has been developed a model for designing affiliation clothing arising from cultural heritage for tourism needs, which has been checked in practise. A new model for interpreting cultural heritage into a clothing image consists of five important and indispensable phases: preparation/research – choice of representative local story; designing affiliated symbol, designing clothing with implemented affiliated symbol, production planning process and manufacturing, promotion and acceptance of clothing.*

*This paper presents the implementation of the model into a design processes for a known client, in this case a local tourism organisation. The designer seeks practical and innovative solutions throughout the design process, firstly from the definition of the local symbol, through collaboration with a client and the public, to the design of an affiliated symbol and its application in the clothing image, the production planning process and manufacturing, and finally to the presentation of products to the public and the promotion.*

## KEYWORDS

*Affiliated clothing, tourism, affiliation symbols, fashion design, cultural heritage*

---

## INTRODUCTION

The local Tourist organization of Jezersko requested the design of new uniforms. The new affiliated clothing design would be used as a “tourist” affiliated garment for the traditional event Sheep ball. Furthermore, newly designed garments would be used as uniform for workers at the Tourist Information Centre as well as for the local people when they present the destination, local products, produce and services.

Through clothing the story of destination should be told, with its visual appearance should be a “clue” to the local stories, which the destination would like to represent [1]. And through visual clothing appearance should be at first glance expressed the traditional vibe of destination, the theme of interpretation and the geographical area characteristics. A clothing image should also be consistent with the way customers dress, as well as being adapted to working conditions and job diversity, with

a comfortable cut and materials, and easy to maintain. Staff should identify themselves with the clothes and feel good in it, and that's why the clothing must allow for combining and individual accessories [2].

If we follow Knific [3] who highlights that clothing image has a lot of meanings, which through its appearance completes a comprehensive visual image of the mythical stories which describe it, we can achieve all goals by very good and structural design. The main challenge in design refers to the visual interpretation of selected heritage stories and the way they are applied in clothing, so visitors will at first glance connect them to the destination, while at the same time the locals will take them for their own.

As Copeland & Hodges suggest, the clothing themes of the representatives and performers at festivals and presentations of the destination play a key role in the perception of what is traditional or heritage interpretation [4]. Affiliated clothing allows the community to be recognizable from the outside and to reinforce an essential identity communication between its members. Through a clothing image, both tourism workers and local people are able to convey a message within the community and also to visitors. By dressing "traditionally", members not only present an image but also perceive the local tradition [5]. It is about the aesthetic experience through which all senses are involved and garments are the medium of communication with a group, strengthening a certain aesthetic sense of belonging and of presenting themselves [5].

### **Affiliated Dress**

Dress, especially affiliated dress, is a form of non-verbal communication – a means of interaction conveying a message through symbolism. Affiliated clothing is a type of dress which enables the reception and promotion of ideas, and makes it easier for individuals and groups to identify the roles which they are to present through their clothes [3]. In the region involved in this study, expressing affiliation through a clothing image is mostly associated with affiliated costumes, which is understood as costumes for special occasions [6]. The development of the region affiliated costume began in the second half of 19th century, as a special form of manifesting identity through clothing image [7]. Therefore, the identity which is expressed through clothing should not only be sought in the cultural heritage and its symbols, but also, and above all, in the recreated stereotypes which were asserted through the clothing heritage.

According to Copeland and Hodges modern forms of national costumes are in a strong visual contrast to traditional styles and performing traditions as business and costume making skills have been replaced by mass production [4]. Transformations from individuality to uniformity and consequently to modifications based on one's own comfort level can also be observed. A shift in



traditional dress styles has fostered a division between those who emphasize tradition and those who embrace the idea of the modernization of traditional costumes [3, 4].

Under the influence of tourism, artificial constructs are emerging which falsely represent the clothing of the past and invented traditions. They also gain new images through repeated interpretations in traditional events, and over time they gain “recurrent authenticity” and are accepted as “authentic” by tourists and cultural producers [3, 8, 9].

## **EXPERIMENTAL**

### **Model for interpreting cultural heritage**

The methodology of research through design that has been relevant also for the field of fashion design is according to Findelie the most relevant for design practice, but at the same time it points out that this method of research is not sufficient for scientific standards, although this approach project-grounded research produces original knowledge [8]. The model of interpretation of cultural heritage in clothing has been developed at active research through design in two projects dealing with designing of affiliated clothing for tourism [11]. One of them will be presented in the following chapter.

The affiliated dress is supposed to become a symbol which community members can identify with. Its form it should include the correct balance of fashion, trends, cultural aspects, aesthetics, comfort, durability and price [12]. At the same time, it must include symbolic signs and elements from the past, and also the clothing practices which must be appropriately modified to create a new tradition. This is a phenomenon which can be contextualized within Hobsbawm’s term of “invented traditions”. These are created in contemporaneity, with the reiteration and implementation of certain rules creating allusions to the continuity with the past [13].

A model for interpreting cultural heritage into a clothing image consists of five important and indispensable phases [11]:

1. Preparation/research – choice of representative local story,
2. Designing affiliated symbol,
3. Designing clothing with implemented affiliated symbol,
4. Production planning process and manufacturing and
5. Promotion and acceptance of clothing.

### **In Search of Typical Symbols in the Cultural Heritage of the Jezersko Region**

The design of a clothing image for the Jezersko area is based on a similar premise – the artificial construction of a clothing image seeking inspiration in cultural heritage, which will spread the notion of a “traditional” clothing heritage by repeated use at traditional events and tourist shows. Thus the

constructed clothing image would over time be recognized and become part of the identity of the people of Jezersko.

The preparation/research phase consisted in: a literature review of ethnological and historical records, cultural heritage and traditional crafts; an overview of tourism and local development strategies; an interview with the client and locals about local tradition, living heritage stories, traditional crafts and skills and finally contemporary clothing habits. Jezersko is an Alpine valley surrounded by high mountains with a small glacier lake and the spring of mineral water that attracts active visitors. In the north, Jezersko borders with the Republic of Austria, which is why there is a strong influence of the neighbouring country. Female workers at Tourist Information Centre and locals, usually at the reception of visitors, were costumed in "dirndl" purchased in Austria, which according to them »look Slovene«. Dirndl is a traditional feminine dress worn in Germany, Austria and Switzerland, based on the traditional clothing of Alps peasants. The men were dressed in leather pants up to their knees and checked shirt. Since this type of clothing was accepted positively by the visitors, locals wanted for newly designed clothing a silhouette alike to "dirndl", but also comfortable and "with more touch of Jezersko".

Designing affiliated „symbol” meant seeking for appearance/application of the symbol in the past and transformation into a recognizable symbol considering technological possibilities and limitations of implementation. Past dressing practices and style in Jezersko region were checked with the use of an overview of clothing practices through older photographs and memories of local people, who once used home wool and sheep fur to make clothes. Designing clothing pieces with implemented affiliated symbol included creation of coquis images, selection of appropriate production technique, colour collection, selection of fabrics, production of prototype garments, evaluation of the collection of affiliated clothing with client and potential wearers (community representatives - locals). We were asked to design two collections of affiliated clothing, a collection for everyday wear, easy to maintain, comfortable and affordable, whereby individual affiliated clothing pieces can be combined with jeans trousers, and a collection of affiliated clothing for special occasions.

Jezersko is also identified with the autochthonous sheep of the Jezersko-Solčava breed. A few farms deal with sheep farming but wool is mostly discarded. Precisely because of the connection with the local tradition and locally produced material, we wanted to highlight products from domestic sheep wool as a distinctive element and affiliated symbolic sign. After consultation with the locals, it was found that they still maintain the tradition of wool spinning, hand knitting and felting. Due to the great desire to use local sheep wool for the production of knitwear, the possibilities of machine knitting were tested. A sweater sample was produced with single-thread yarn from wool fibres of Jezersko Solčavske sheep breed, but due to the uneven twisted woollen yarn and technical problems the machine knitting was not feasible for larger production. Nevertheless, we incorporated woollen

knitwear into a modern affiliated clothing because of the local tradition, but we focused on knitwear that can be delivered / manufactured in the local area.

Furthermore, we wanted to express an "Alpine style" of dressing habits. Therefore, the colour combinations are associated with the natural colour of raw sheep wool in combination with blue and green, presenting the contrast of sheep in mountain pastures with clear blue sky, with herdsmen in leather pants, white shirt and wooden clogs, but with a consideration of cultural heritage.

We anticipated the use of natural materials for individual clothing pieces and we defined a colour scheme in a blue and green combination that follows the colours of the municipal coat of arms. An important starting point for designing a new affiliated clothing was its suitability for working in hospitality establishments and the possibility of combining them with modern daywear, for example, jeans.



Figure 1. Affiliated clothing design sketches and women's sweater prototype (Design and Photography: J. Vilman Proje)

## RESULTS AND DISCUSSIONS

A key piece of new affiliated clothing image of Jezersko is a knitted woman's and a men's sweater buttoned in the front, made from grey yarn in a mixture of 70% wool and 30% acrylic, with braid pattern. We were forced to use a yarn from a mixture that was available in a knitting workshop. Colour details appear on the inner side of the collar (blue with a green line) and on cuff patents. Scarfs and caps were produced in the same yarn and colour combination.

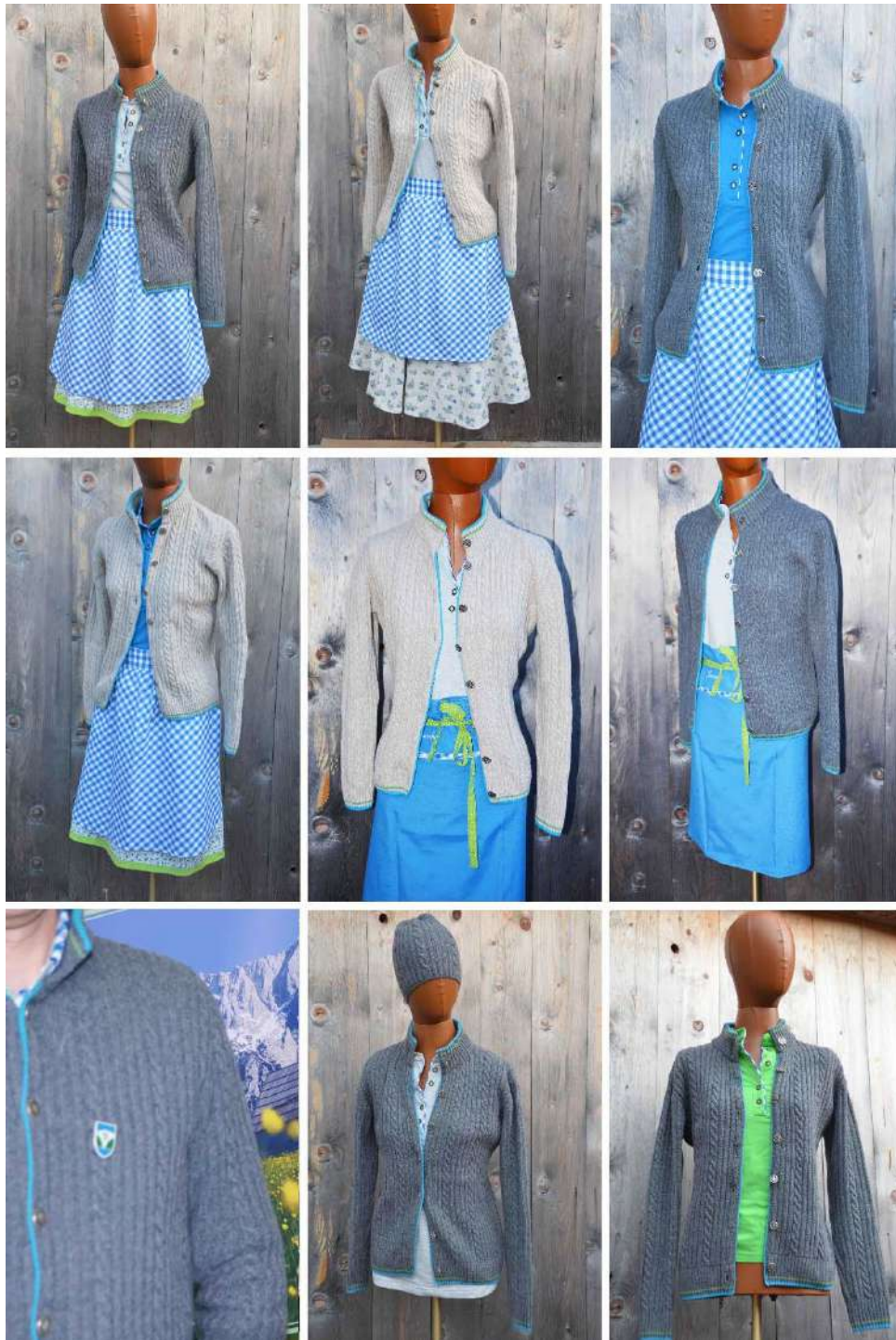

Figure 2. Various combinations of individual affiliated clothing pieces (Design and Photography: J. Vilman Proje)

Women's garment consists of a cotton shirt, wide skirt to the knee and apron and the overall appearance is rounded with a knitted sweater. The selected fabrics for the production of skirts and aprons are patterned, combining one piece from the fabric with floral pattern and the other piece from the checked fabric since skirt and apron are traditionally always worn together. In addition, there is a blue, green or grey cotton t-shirt that can be worn with jeans and upgraded with fashion accessories (headscarf, knitted cap or scarf). For man's affiliated garment, a cotton green t-shirt with a checked

collar and a grey sweater was chosen. The affiliated clothing collection included also fleece jackets and bartender aprons suitable for the workers in bars and restaurants.

For special occasions, an elegant women's and men's garment in a shaded grey colour, with green embroidered details were designed. Women's clothing for special occasions consists of a narrow skirt with two hidden wrinkles at the front and a jacket with a Russian collar and green embroidered details, and a blouse with small floral pattern trimmed with a lace. The men's jacket is quite similar to a women's one and it is complete with a white or checked shirt, trousers of the same material or jeans pants.

After the evaluation of prototypes with client and potential wearers the production planning process started: final selection of fabrics, colours, cuts and pattern, selection of manufacturers / contractors, cooperation with manufacturers, managing, graphic design of labels and packaging. Promotion and acceptance of affiliated clothing was performed via different local media, events and tourist promotions. A catalogue of affiliated clothing for Jezersko was prepared to facilitate presentation and sales of the affiliate clothing as they predicted that individual pieces would be sold in a Tourist information centre aimed to both locals and visitors.



Figure 3. Affiliated women's garment for special occasions (Design and Photography: J. Vilman Proje)

## CONCLUSIONS

The task of designing an affiliated clothing image extends beyond the field of fashion design. The key moment in the process is the definition and choice of the heritage story which follows the development strategy, lifestyle and vibe of the destination, and the non-material heritage which is still alive among the local people and which identifies them.

The newly-designed affiliated clothing should express the character of the area both stylistically and visually. Thanks to the carefully-studied planning, the clothing complies with the guidelines of the tourist destination, encompassing the elements of not only the previous clothing practices and forms, but also current clothing fashions, and through subtly included affiliation signs it also enables locals and visitors alike to identify the clothing as coming from *Jezersko*.

Engaging the client and the future wearers of the affiliated clothing in the process of design is also an important function in the design of an affiliated clothing image, as they were thereby included in the decision-making process. This ensured a personal relationship between the users and the end products, through which identification with the affiliated clothing image was achieved, and the clothing was also more effectively further promoted.

The artificially constructed affiliated clothing image seeks inspiration in the cultural heritage which should spread the notion of the “traditional” clothing heritage by the means of reiteration and use at tourist, traditional and business events. Thus the constructed clothing image should over time become recognized as part of the identity of people from *Jezersko*. It helps the local cultural heritage to integrate into modern life and to recreate a story through which *Jezersko* can be identified, thus designing a new tradition.

## REFERENCES

- [1] Entwistle, J. & Wilson, E. (Eds.) *Body dressing*. (pp. 33-58), Oxford, New York; 2001.
- [2] Michael A. *Best impressions in hospitality: your professional image for excellence*. Albany (NY): Delma Learning; Australia: Thomson Learning; 2002.
- [3] Knific B. *Folklornikom s(m)o vzeli noše: Kostumiranje folklornih skupin – med historično pričevalnostjo in istovetnostjo*. Ljubljana: ZRC, ZRC SAZU; 2010.
- [4] Copeland R, Hodges N. *Exploring Masquerade Dress at Trindade Carnival: Bikinis, Beads, and Feathers and the Emergence of the Popular Pretty Mas*. *Clothing and textiles Research journal*. 2014; 32 (3):186–201
- [5] Bazin Y, Aubert-Tarby C. *Dressing preofessional, an aesthetic experience of professions*. *Society and Business Review*. 2013; 8 (3):251–268.
- [6] Knific B. *Slovenskost pripadnostnega kostumiranja Gorenjcev : Vizualna pričevanja o pripadnostnem kostumiranju Gorenjcev in nekaj misli o gorenjskosti “slovenske narodne noše”*. In *Gorenjska. Etnologija in pokrajine na Slovenskem na primeru Gorenjske*. Edited by T. P, Ljubljana: Slovenian Ethnological Society; 2012.

- [7] Knific B, Vprašanje narodne noše na Slovenskem: njen razvoj od srede 19. stoletja do 2. svetovne vojne. *Etnolog*. 2012; 13(64):464-467.
- [8] Morgado M, Reilly A. Funny Kine Clothes: The Hawaiian shirt as popular culture. *Paideusis- Journal for interdisciplinary and Cross-Cultural Studies*. 2012; 6: D1-D24.
- [9] Young P. Fashioning Heritage: Regional Costume and Tourism in Brittany, 1890–1937. *Journal of Social History*. 2009; 42(3): 631-656.
- [10] Findeli A, Brouillet D, Martin S, Moineau C, Tarrago R. Research Through Design and Transdisciplinarity: A Tentative Contribution to the Methodology of Design Research. In *Focused - Current Design Research Projects and Methods, 4th Swiss Design Network Symposium, Mount Gurten, Berne, Switzerland; 2008*.
- [11] Vilman Proje J. Interpretation of Slovenian heritage into contemporary clothing product collection, Ph.D Thesis, Ljubljana : University of Ljubljana, Faculty of Natural Sciences and Technology, Department of Textiles, Graphics Art and Design, 2018.
- [12] Šterman S. Uniforme kot funkcionalno oblačilo z močjo komunikacije. *Tekstilec*. 2012; 55(2): 140-147.
- [13] Hobsbawm E. *Inventing Tradition*. In *The invention of Tradition*. Edited by E. Hobsbawm and T. Ranger, Cambridge: Cambridge University Press;1983.

# KNITWEAR AND STYLE

**Marjanca ŠTEMBERGER<sup>1</sup>, Alenka PAVKO-ČUDEN<sup>1\*</sup>**

<sup>1</sup>University of Ljubljana, Faculty of Natural Sciences and Engineering, Department of Textiles, Graphic Arts and Design, Snežniška 5, 1000 Ljubljana, Slovenia, \*email: alenka.cuden@ntf.uni-lj.si

---

## ABSTRACT

*It is difficult to set a general definition of style. Through history, different styles were named descriptively according to their main characteristics, e.g. realism, impressionism, dadaism, op-art etc. In our research we investigated how style is manifested in knitwear collections of selected designers. Three iconic designers were analysed: Missoni representing typical geometric color patterns, Kenzo representing organic color patterns and Issey Miyake representing structural patterns. The use of artistic elements (point, line, light-dark, colour) in their collections was studied. In art theory the basic artistic element is a point, while in knitting a loop is the corresponding basic structure element. An equivalent for a line is a yarn which together with the loop creates the surface/texture or the structure of the knitted fabric – light-dark. Colour is the element used in different combinations and hues in knitting as well as in pure arts, i.e. paintings. All three fashion designers whose work we have studied use patterns and knitted structures in their collections as significant elements which define their style. Although they all incorporate the same basic elements of knitted structure (loops and their derivatives, yarns, colours, textures) in their collections, each of them exhibits his own knitting technique which leads to stylistic differences among them. They use the same basic elements, but in different combinations. Therefore, they create their own style reflecting their specific sentiments, feelings and intentions to present their own vision of reality.*

## KEYWORDS

*knitting, knitwear collection, fashion, style*

---

## INTRODUCTION

### STYLE AND FASHION

It is difficult to set a general definition of style. Through history, different styles were named descriptively according to their main characteristics, e.g. realism, impressionism, dadaism, op-art etc. Wölfflin, Wollheim and Alpershe [1-3] speak of style, but none precisely defines what style is. They only describe the style, present some of its properties and characteristics, but do not speak about its structure: how it is structured, what determines the structure of the style, and how it is revealed in reality.

Theories of styles lack integration [4]. In his seminal work *Caves* [5] used the term “style” over 50 times but not consistently and it was never clearly defined. For example, when *Caves* [5, p. 43] describes the relationship between galleries and artists, on the same page the word “style” is used to refer to cubism as an artistic movement, and then to talk about the evolving personal style of an artist. Therefore, a style is normative not only to the extent that it is imposed from the outside, but also



because it is an expression of what is specific about an artist. In this case, the individual style of an artist is an expression of his “true self” [4].

Style has become a very broad concept, covering all areas of human creation and engagement in social life [6]. For Simmel [7] style in the arts is evidence of a key tension – individuality vs. generality. In his view, style negates individuality by providing artists with general rules that constrain their aesthetics. However, exceptional individuals – breaking conventions – can generate styles of their own that others can choose to imitate. Historical examples include Michelangelo or Mozart [4,7]. Gadamer [8] also sees style as essentially normative, i.e., as a set of rules to be followed. Godart [4] defines style as a durable and recognizable pattern of aesthetic choices. Before him, Gadamer [8] offered another understanding of the concept – that style is an expression of taste. For Gadamer [8], each individual has certain tastes (e.g., in arts, fashion, and food). He explains that style is how tastes are expressed, thus shaping the set of socially acceptable elements that are available to individuals at one point in time and space. A style leads to discrimination among fashions by individuals based on their tastes; in this sense, style plays a crucial role in the dynamics of social life [4]. On the other hand, for Veblen [9] styles in fashion and other creative industries are seen as vehicles used to express one’s status [4]. Also, Carr and Pomerot [10, p. 6] state that clothing expresses status.

In the field of textile and clothing design, individual styles appear, which are reflected in selected materials with certain optical and tactile effects, textiles made with selected, specialized techniques, and in certain structures, patterns and garment styles [6]. Style may be seen as descriptive, such as in fashion magazines that indicate what the key season styles are [11]. Based on the global market research, fashion trends are formed. These affect fashion in a given period: both patterns and textures as well as shapes - dress styles. Fashion designers are familiar with fashion guidelines which are transformed and used in their collections in their own inspiration and judgment [6].

As Godart comments [4] style is not the opposite of fashion but rather a necessary condition for creative innovation in fashion. Style enables fashion; without style, there is no fashion. To understand fashion one has to understand style, because in essence fashion is about the diffusion of styles rather than the diffusion of clothes [4]. In an interview with Paris-based American journalist Joseph Barry [12], the French couturière Gabrielle “Coco” Chanel famously said, “Mode (e.g. fashion) passes; style remains.” Although today it is something of a cliché, this became the motto of the Chanel brand. What the renowned fashion designer implied was that whereas fashion is seen as a series of unending superficial changes imposed on individuals, style is thought to be the embodiment of good taste and the true self of the creator [4]. In 1975, French couturier Yves Saint Laurent offered a similar insight: “Fashions fade, style is eternal” [13, p. 876].

Their statements can be understood, that in the art of making clothes, it is not the trends of the moment that should command a designer’s creativity, but rather their innate sense of aesthetic

judgment. In other words, for Chanel and Saint Laurent, regardless of the trends of the day, fashion designers – couturières and couturiers – should follow their own styles, i.e., something that makes their judgment unique, an unmistakable expression of who they are. In so doing they inscribe their identities upon the context of an epoch and a place [4].

The development of new textile and clothing technologies and processes is important for the design of the final products. Different aesthetics and styles appear in the field of 2D textiles (non-wovens, woven and knitted fabrics: manufactured, dyed, printed and finished by the use of new raw materials and new technologies) as well as in the field of 3D textiles and clothing, i.e. seamless and sewn apparel and interior textiles. New raw materials and new technologies keep constantly evolving, changing, complementing, inspiring and giving different starting points for inspiring new styles in textiles and clothing [6].

Therefore, the purpose of the research was not to define a style in general or a style in the design of textiles and clothing, nor to classify artistic or design work within the frames of certain styles. The objective of the research was to determine the structure of style in the collections of selected fashion designers and periods, and to find out what are the elements that define each individual style. Further objective was to specify how the structure of the style can be detected in a clothing collection, more precisely in a knitwear collection of a selected fashion designer over a selected period (season).

### **Contemporary knitting**

Knitting has long been characterized by interlacing technologies within the knitting sector, seeking ideas from other mechanical textile technologies, and also in the field of chemical textile processes. Recently, also in the knitting sector, social responsibility in the exploitation of resources has been emphasized. Especially in Europe, knitting machines that offer environmentally friendly manufacturing techniques, with less impact on the environment and with significant reduction of the waste generation have been privileged. Increased efficiency, i.e. increased knitting speed, has also become an important issue for which it appeared not so long ago that some manufacturers already reached the peak [14]. High knitting speed and efficiency go hand in hand with fast fashion, a contemporary concept reflected in clothing collections designed and manufactured quickly and inexpensively. Fast fashion enables consumer to afford current clothing collections at a lower price.

On the other hand the so called slow or conscious fashion has developed to oppose the negative sides of the fast fashion and to emphasize classic style over brief trends or fads. Slow fashion includes complex knitting technologies as well as knitting craft. For example, the Japanese draw less of a distinction between crafts and fine arts, as is evident in museum collections. As the constant textile innovations carried out by companies such as Miyake Design Studio and the Nuno Corporation show,

the ability to combine craft skills with an understanding of both old and new technologies can provide the ideas which can influence fashion for a long time ahead [15].

In the climate of accelerated technological change which has prevailed over the past decades, new technologies and new fibres have transformed knitting into the most innovative and exciting textile medium, and knitwear has gained a place at the forefront of contemporary fashion. Never before have so many designers and artists experimented with knit as a basis for their work, exploring qualities of knitted construction. A new generation of fashion designers who are pushing the boundaries have reinvented the art [15]. In addition to weft knitting, warp knitting also entered the field of fashion. Warp knitting is mostly applied for interior and technical textiles but thanks to the Missoni family, it also significantly marked the knitwear fashion.

The irreplaceable part of the knitting sector are seamless knits, made mostly by flat knitting as well as on body-size circular and warp knitting machines. Seamless knitting technology can not compete with continuous knitting in terms of productivity, but is indispensable in the production of hi-tech clothing and other products otherwise made conventionally by sewing [16]. Seamless or so called wholegarment flat knitting machine producers like Stoll and Shima Seiki offer trend concepts in order to inspire and educate knitwear designers and producers to explore and exploit the possibilities offered by this new technology.

In knitting as well as in other textile technologies, attention is paid to the recycling of raw materials and other resources. Work phases and technological processes have been merged to save the production times [14]. To create the maximum with one piece of cloth is the fundamental philosophy within which Miyake has operated since he set up his studio in 1970. No waste, minimum cutting and seaming, and in the case of his famous a-POC (a piece of cloth) concept, no after knitting processes at all [15]. It proves that over the last decades, Miyake has been the pioneer of the sustainable knitting fashion who has inspired both designers and machine producers.

According to Lee [17, p. 6] contemporary knitting is about original thinking and a sensitive handling of technique, materials and concepts. Fundamentally, knitting is all about relationship between stitches (loops), gauge, tension, knitting medium (material) and finished fabric. Yarns and fibres are substitutes for drawing's pen, pencil or charcoal, while stitch structures compare to making marks on a surface [17]. Therefore, knitting technique and art are interconnected as are artistic elements and elements of knitted structure.

#### **ARTISTIC ELEMENTS AND elements of KNITTED structure**

During knitting, yarns are bent and knit into loops. A knitted structure is composed of intermeshed loops. In the horizontal direction, the loops are intermeshed to courses, and in the vertical

direction into wales. Therefore, the basic element of the knitted structure is a loop. Complex knitted structures are composed of different loop types and their derivatives, depending on the knitting process (full loop; a straight yarn portion or a so-called „miss“; a bent yarn portion that is not intermeshed into a loop, or a „tuck“; an inclined loop or a “racking stitch”, etc. ) [6].

In their creative process, designers use the same artistic elements as fine artists, i.e. painters. The basic artistic elements are: point, line, light-dark and color together with syntactic rules [18,19]. A combination of different elements and syntactic rules refers to different artistic languages, which have their own artistic grammar, i.e. a different style [20-23].

Designers choose their own artistic elements in the form of elements of knitted structure to produce a knitted fabric in accordance with their vision and expression. In our previous research [6, 24] it was proved that artistic elements are equivalent to elements of knitted structure (Table 1). One of the basic artistic elements is a point, while in knitting, a loop is the basic structure element used in weft and warp knitting. In knitting, an equivalent for artistic element - line is yarn intermeshed into a knitting course or wale which form a stripe. Different types of loops and their derivatives aligned in courses and wales create a surface of a knitted fabric: a texture characterized by shadows and composed of light-dark elements. Color is the element used in different combinations and hues in fine arts as well as in knitting [6, 25-27]. For final surfaces, plastic variables: height, width, weight, position, direction, number, density, texture, which define the form are important. When these elements are changed, the form changes as well [19-22]. New meanings, and new emotional and sensual characteristics/properties are obtained, e.g. a small square is perceived differently than a big one. Knitting material, knitting machine and knitting process also define the knitted fabrics construction parameters, i.e. the knitted structure and the parameters/dimensions of the basic structure – the loop [24-27].

The artistic laws are equivalent to knitting principles, which result in different knitted structures made from yarns of different material composition, color jacquards with different effects on the face and reverse side of the fabric, and different shrinking and folding effect [6].

Table 1. Artistic elements and elements of knitted structure [24]

artistic element	point	line	light-dark	color
element of knitted structure	loop	stripe (knitted course/wale)	texture/structured jacquard (open/close knitted structure, transparent/opaque structure bulge/depression in structure)	color jacquard

## EXPERIMENTAL

Our preliminary research [24] analyzed the Missoni, Miyake and Rykiel spring collections 2014, 2015 and 2016 in order to prove that artistic elements are equivalent to elements of knitted structure (Table 1). Further research [6] was focused to the structure of style in knitwear collection; in the study exploring exclusively Missoni's collections, it was assumed that the style has an axiomatic structure. The analysis was based on axiomatic method justified by Muhovič in his article Anatomy of painting style [20]. Muhovič [20] analyzed the connection between fine arts and the axiomatic method. He based his analysis on the findings that artistic forms are reflected in sign systems. He assumed that the systems of artistic signs have an axiomatic nature and organization. Muhovič claims that artistic forms have several properties that are consistent with the basic characteristics of axiomatic systems: complexity, formalism and organization [20, p. 44-45].

An axiomatic system is a system of elements that are functionally interconnected. The significance of an individual element depends on the function and relations that it has in the context of the whole. In fine arts, these relationships are combined in an artistic form that combines art elements into a whole. Artistic forms have axiomatic features. The axiomatic system in textile design consists of axioms, definitions, syntactic rules, and results (in our case: a specific knitted fabric) [6,20,28].

In the present research the same axiomatic scheme was used and complemented with an in-depth theoretical study of style and style-fashion relationship [6]. The basic artistic elements/elements of knitted structure used by selected fashion designers in their collections were compared and analyzed. It was observed how style is manifested in knitwear collections through different periods of fashion seasons. Recent collections of three iconic knitwear designers: Missoni, Kenzo and Miyake were analyzed. Missoni was selected for representing typical geometric color patterns, Kenzo for organic color patterns and Issey Miyake for structural patterns. Their collections were analyzed for the recent three seasons, i.e. spring/summer 2017, spring/summer 2018 and spring/summer 2019 [29-37]. Fashion trends which influenced the collections were also examined. All three fashion designers use patterns and knitted structures in their collections as significant elements which define their style. Therefore, their collections were inspected and compared on the basis of structural artistic elements (point, line, light-dark, colour) and elements of knitted structure (loop; knitted course/wale; color jacquard; texture, porosity and bright-dark shadow effects).

## RESULTS AND DISCUSSION

Fashion trends for the selected seasons are summarized and systematically presented in Table 1 [24]. The results of the analyses of the selected knitwear collections are presented in Figures 2-13

whereas the factors defining the individual designer's style are presented in Figure 2 (season spring/summer 2017) [29-31], Figure 6 (season spring/summer 2018) [32-34] and Figure 10 (season spring/summer 2019) [35-37]. The collections of individual designers for the single selected seasons are shown on Figures 3-5, Figures 7-9 and Figures 11-13 [38-46].



Figure 1. Fashion trends Spring/summer 2017, 2018, 2019 [29-37]

Fashion trends for the season spring/summer 2017 (Figure 1) [29-31] found inspirations in nature, ethnic patterns, illusion between reality and fantasy, and in virtual world. The suggested colours were blue, purple, silver, black, white, red, yellow and fuchsia. The use of natural materials was proposed, so knitting yarns for the collection were made of linen, cotton and silk. Patterns included tribal motifs, stripes, floral, animal prints, 3D geometrics, polka dots and lace. Textures were structural jacquards, stripes, porous surfaces, compact and smooth structures.

When comparing the factors defining the individual designers' collections, i.e. inspiration, colours, yarns and textures (Figure 2) [38-40] which the three designers used in their spring/summer 2017 collections, we detected some similarities. Missoni and Kenzo (Figures 3 and 4) [38,39] found some inspirations in 70's and 80's while Miyake's inspirations (Figure 5) [40] were aboriginal paintings and the Superman theme song. All three designers used similar colours: gold, yellow, pink, green, blue, orange, black, white and purple. Missoni also included rainbow-shade colours. Yarns in all three

collections were coloured, with incorporated lurex, nylon, vinyl, glittering and natural effects. Lines and patterns in collections were horizontally and/or vertically oriented, twisted and/or oblique. Zigzag lines were only present in Missoni's collection, as they are characteristic for the house of Missoni. They were used in the rainbow-hued sweater dress as well as in marbled pink and yellow knitted skirt. Kenzo used coloured patterns and glittering in his collection while Miyake's collection was based on trapezoid shapes and stretched structural patterns which created a flexible texture [38-40].

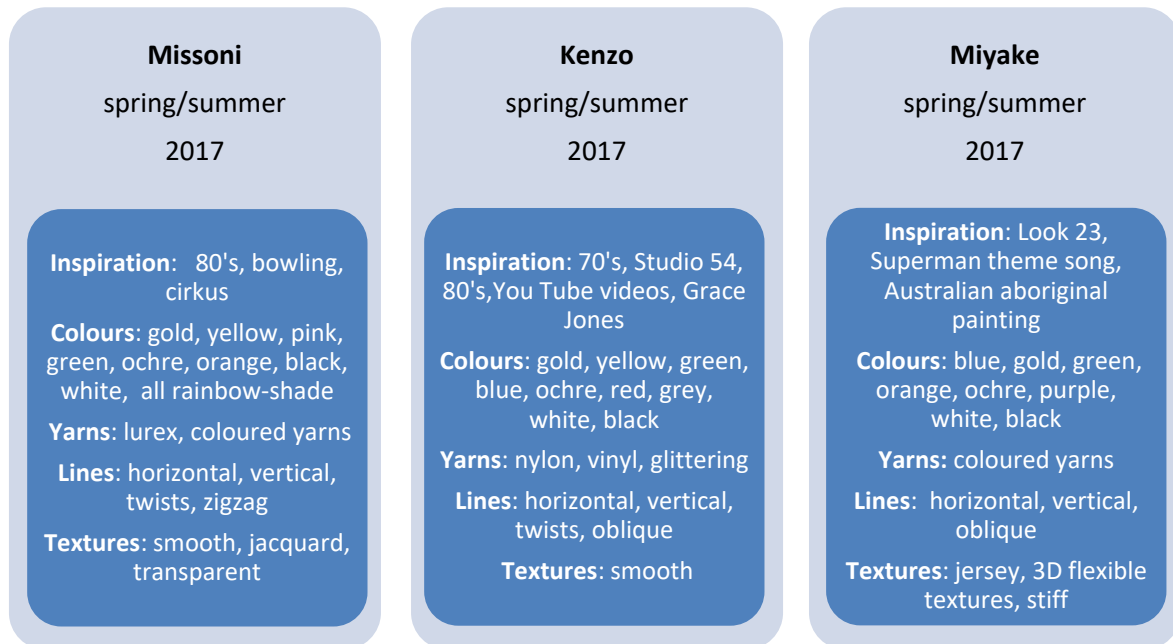

Figure 2. Spring/summer 2017 collections of Missoni, Kenzo and Miyake [38-40]



Figure 3. Missoni spring/summer collection 2017 – selected models [38]



Figure 4. Kenzo spring/summer collection 2017 – selected models [39]



Figure 5. Miyake spring/summer collection 2017 – selected models [40]

For the collections spring/summer 2018, designers found their inspiration in very different associations (Figure 1) [32-34]. Missoni [41] was inspired by Homer's Odyssey, Kenzo [42] by supermodel Sakamoto and Memphis movement, and Miyake [43] by North Pole and Iceland. The inspirations presented in fashion trends spring/summer 2018 (Figure 1) [32-34] were very different from the ones individual designers considered in their collections (Figure 6: Nefertiti in Ibiza, Malevich in Sorrento, Mollino in Teheran, modernism, etc.) [41-43].

However, the colours the three designers used were similar: yellow, green, blue, coral red, pink, purple, orange, black and white. Yarns were coloured, sometimes including lurex, elastic, performing stretch. For Missoni zigzag lines were distinguished (Figure 7). The Homeric theme influenced black knitted structures, yellow dresses, strong presence of white and soft honeycomb textures. Kenzo



showed vertically striped socks, horizontal and organic lines (Figure 8). Miyake lines exhibited honeycomb like look and were three dimensional (Figure 9). Missoni's and Kenzo's textures were smooth and transparent. Miyake's textures were trilateral, 3D, also tricksily pleated (Figure 6) [41-43].

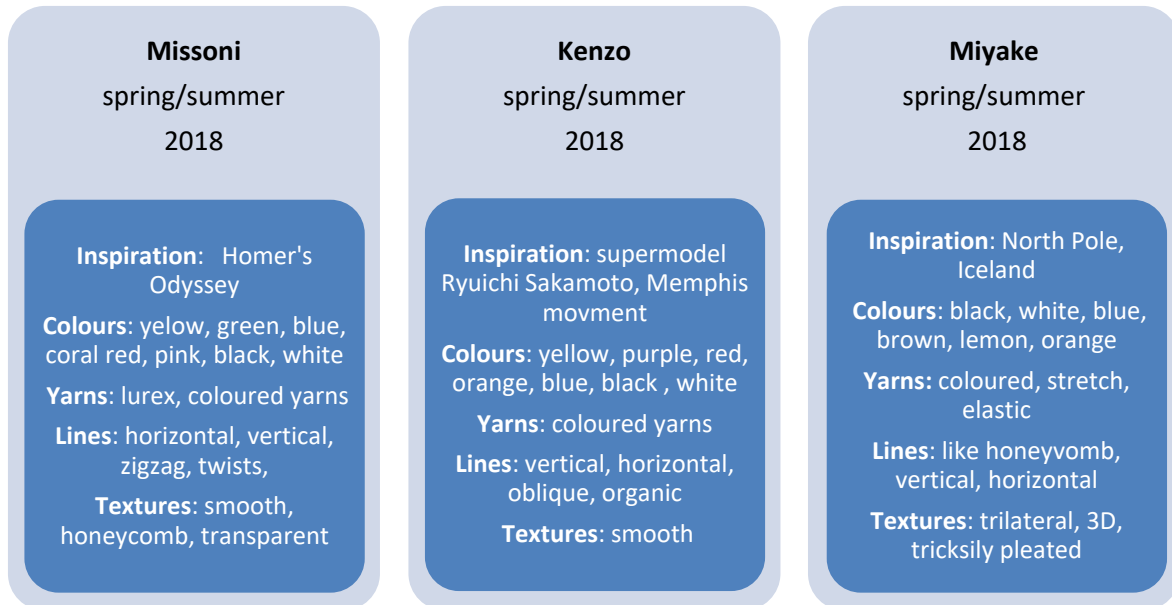

Figure 6. Spring/summer collections 2018 of Missoni, Kenzo and Miyake [41-43]



Figure 7. Missoni spring/summer collection 2018 – selected models [41]



Figure 8. Kenzo spring/summer collection 2018 – selected models [42]



Figure 9. Miyake spring/summer collection 2018 – selected models [43]

Inspirations for the fashion trends spring/summer 2019 (Figure 1) [35-37] were: the 60's, ethnic mood, aura and light, bio-material, earth, water and air, fine porcelain and precious stones, Jacques Causteau, Massai and Nureyev. The suggested colours were the basic colours like pearl grey, pink, indigo blue, purple, methalic, silver and turquoise. Proposed yarns were fine, metallic and coloured. Most of patterns were geometric, i.e. stripes, but also floral, 3D and lace. Textures were smooth, compact, transparent and jacquard.

The designers considered some of the inspirations suggested in fashion trends for spring/summer 2019 (Figures 1 and 10) [35-37, 44-46]. All three designers used almost the same colour palette and yarn selection: lurex, cotton, coloured and stretch yarns. Patterns were geometric including stripes (horizontal, vertical, zigzag, twists), floral and 3D, forming smooth, compact, transparent and jacquard texture. Missoni [44] used simple beachgoer and spring motifs with lots of

lurex yarns; zigzag stripes remained essential elements of the collection. Kenzo [45] introduced plenty of glittering colours like electric blue, nylon yarns, graphic patterns like checks and diamonds, and exhibited smooth textures. Miyake [46] included new innovative material dubbed Dough Dough, used for the sculpture-garments, "ready-to-mould", which can be modelled and remodelled to suit the wearer's whim. The fabric was made using polyethylene and was not steam after-treated, so it remained flexible.

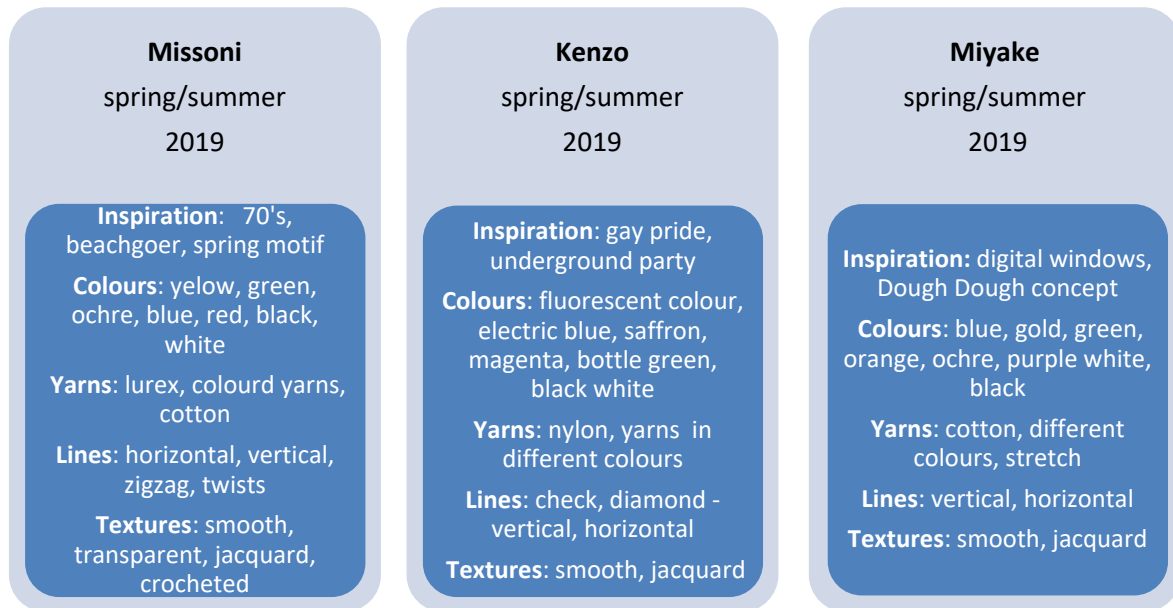

Figure 10. Spring/summer collections 2019 of Missoni, Kenzo and Miyake [44-46]



Figure 11. Missoni spring/summer collection 2019 – selected models [44]



Figure 12. Kenzo spring/summer collection 2019 – selected models [45]



Figure 13. Miyake spring/summer collection 2019 – selected models [46]

## CONCLUSIONS

All the investigated spring/summer collections of the selected designers followed to some extent the corresponding fashion trends concerning yarns, colours, patterns and textures. In all Missoni collections characteristic zigzag lines, space-dyed look, colours shading into one another, rainbow effect and smooth, transparent surfaces were recognized. For some models, Kenzo's palette was similar to Missoni's, but different yarns (nylon, vinyl, glittering) were used. Lines were vertical, horizontal, also oblique. Textures were smooth, some jacquard structures were also included. Miyake's inspirations were independent, innovative and were reflected in innovative technical textures with new flexible form experience.

All three fashion designers use materials, colours, patterns, knitted structures and knitting techniques (including gauge and machine settings) in their collections as significant elements which

influence the surface of knitted structure. Although they all incorporate the same basic elements of knitted structure (loops and their derivatives, yarns, colours, textures) in their collections, each of them exhibits his own manufacturing technique which leads to stylistic differences among them. They use the same basic elements, but in different combinations. Therefore, they create their own style reflecting their specific sentiments, feelings and intentions to present their own vision of reality and their own interpretation of fashion.

## REFERENCES

- [1] Wollheim R. The question of style in philosophy and the arts. Cambridge: Cambridge University press; 1995. Chapter 2, Style in painting; p. [37-49].
- [2] Wölfflin H. Principles of art history : the problem of the development of style in later art. New York: Dover; 1950. 256 p.
- [3] Alpershe S., Lang, B. (ed.) The concept of style. Revised and expanded ed. London: Cornell University press; 1987. Chapter 4, Style is what you make it: the visual arts once again; p. [137-162].
- [4] Godart FC., Candace Jones (ed.), Massimo Maoret (ed.) Frontiers of Creative Industries: Exploring Structural and Categorical Dynamics. Bingley: Emerald Publishing; 2018. Chapter 5, Why is Style Not in Fashion? Using the Concept of "Style" to Understand the Creative Industries; p. [103 – 128].
- [5] Caves RE. Creative industries: Contracts between art and commerce. Cambridge MA, London: Harvard University Press; 2000. 464 p.
- [6] Štemberger M, Muhovič J, Pavko-Čuden A. Struktura stila v oblikovanju tekstilij in oblačil. *Annales : anali za istrske in mediteranske študije, Series historia et sociologia*. 2018(28)2:255-268.
- [7] Simmel G. The problem of style. *Theory, Culture & Society*. 1991;8(3):63–71.
- [8] Gadamer HG. Truth and method. London: Continuum; 2004. 640 p.
- [9] Veblen T. The Theory of the Leisure Class: An Economic Study of Institutions (New ed.). New York: Dover Thrift; 1994. 256 p.
- [10] Carr H, Pomerot J. Fashion design and product development. Oxford: Blackwell Science; 1992. 175 p.
- [11] Moeran B. More than just a fashion magazine. *Current Sociology*. 2006;54(5):725–744.
- [12] Barry J. The People of Paris. Garden City, New York, NY: Doubleday & Company; 1966. 326 p.
- [13] Andrews R. (Ed.). The Columbia dictionary of quotations. New York, NY: Columbia University Press; 1993. 1090 p.
- [14] Pavko-Čuden A. ITMA 2015 - Sodobno pletilstvo: trajnostna naravnost in kroženje inovacij. *Tekstilec*. 2016;(59)1:63-75.

- [15] Black S. Knitwear in fashion. London: Thames & Hudson; 2002. 192 p.
- [16] Pavko-Čuden A. Tehtextil in Texprocess 2015 : obsežnejši in hkrati bolj usmerjen. Tekstilec. 2015;(58)3:241-242.
- [17] Lee R. Contemporary knitting for textile artists. Batsford: London; 2007. 127 p.
- [18] Butina M. Elementi likovne prakse. Ljubljana: Mladinska knjiga; 1982. 334 p.
- [19] Butina M. Mala likovna teorija. Ljubljana: Debora; 2000. 174 p.
- [20] Muhovič J. Anatomija slikarskega stila : Likovna umetnost in aksiomska metoda. In: Bonča J. editor. Kje je likovna teorija. Proceedings Simpozij v počastitev spomina na profesorja Milana Butina; 3-4 Februarja 2000; Ljubljana, Slovenija. Ljubljana: Visoka strokovna šola slikarstva; 2000. P. 28-69.
- [21] Muhovič J. Likovna umetnost kot področje semiotične artikulacije. Anthropos. 1995;(27)5/6:131-154.
- [22] Muhovič J. Linguistic, pictorial and metapictorial competence. Leonardo. 1997;(30)3:213-219.
- [23] Panofsky E. Three essays on style. Cambridge: The MIT Press; 1997. 256 p.
- [24] Štemberger M, Pavko-Čuden A. Style in knitted textiles and fashion. In: Shaping the future of textiles. Proceedings 17th World Textile Conference AUTEX; 29 - 31 May 2017; Corfu, Greece. IOP conference series, Materials science and engineering. Bristol: IOP Publishing; 2017;254:1-4. Available from <http://iopscience.iop.org/article/10.1088/1757-899X/254/17/172025>.
- [25] Pavko-Čuden A. 2013 Računalniško oblikovanje pletiv in pletenin : skripta. Ljubljana: Naravoslovnotehniška fakulteta, Oddelek za tekstilstvo; 2013. 83 p.
- [26] Pavko-Čuden A. Pletiva in pletenine: skripta. Ljubljana: Naravoslovnotehniška fakulteta, Oddelek za tekstilstvo; 2007. 187 p.
- [27] Spencer DJ. Knitting technology. Cambridge: Woodhead publishing; 2001. 416 p.
- [28] Muhovič J. Leksikon likovne teorije: slovar likovnoteoretskih izrazov z ustreznici iz angleške, nemške in francoske terminologije. Celje, Ljubljana: Celjska Mohorjeva družba: Društvo Mohorjeva družba; 2015. 896 p.
- [29] Collezioni trends. 2015;113:171-172.
- [30] Collezioni trends. 2016;115:50-114.
- [31] Collezioni trends. 2016;116:193-216.
- [32] Collezioni trends. 2016;117:146-194.
- [33] Collezioni trends. 2017;118:86-154.
- [34] Collezioni trends. 2017;119:42-68.
- [35] Collezioni trends. 2017;121:152-178.
- [36] Collezioni trends. 2018;122:98-158.
- [37] Collezioni trends. 2018;123:40-82.

- [38] Missoni spring/summer ready-to-wear 2017. Vogue [Internet]. Available from: <https://www.vogue.com/fashion-shows/spring-2017-ready-to-wear/m-missoni>. [Accessed 3rd December 2018].
- [39] Missoni spring/summer ready-to-wear 2018. Vogue [Internet]. Available from: <https://www.vogue.com/fashion-shows/spring-2018-ready-to-wear/m-missoni>. [Accessed 3rd December 2018].
- [40] Missoni spring/summer ready-to-wear 2019. Vogue [Internet]. Available from: <https://www.vogue.com/fashion-shows/spring-2019-ready-to-wear/m-missoni>. [Accessed 3rd December 2018].
- [41] Kenzo spring/summer ready-to-wear 2017. Vogue [Internet]. Available from: <https://www.vogue.com/fashion-shows/spring-2017-ready-to-wear/kenzo>. [Accessed 3rd December 2018].
- [42] Kenzo spring/summer ready-to-wear 2018. Vogue [Internet]. Available from: <https://www.vogue.com/fashion-shows/spring-2018-ready-to-wear/kenzo>. [Accessed 3rd December 2018].
- [43] Kenzo spring/summer ready-to-wear 2019. Vogue [Internet]. Available from: <https://www.vogue.com/fashion-shows/spring-2019-ready-to-wear/kenzo>. [Accessed 3rd December 2018].
- [44] Miyake spring/summer ready-to-wear 2017. Vogue [Internet]. Available from: <https://www.vogue.com/fashion-shows/spring-2017-ready-to-wear/issey-miyake>. [Accessed 3rd December 2018].
- [45] Miyake spring/summer ready-to-wear 2018. Vogue [Internet]. Available from: <https://www.vogue.com/fashion-shows/spring-2018-ready-to-wear/issey-miyake>. [Accessed 3rd December 2018].
- [46] Miyake spring/summer ready-to-wear 2019. Vogue [Internet]. Available from: <https://www.vogue.com/fashion-shows/spring-2019-ready-to-wear/issey-miyake>. [Accessed 3rd December 2018].

# THE DESIGN OF CUSTOMIZED WORK CLOTHES FOR KINDERGARTEN TEACHERS

Sanja JAKUŠ<sup>1</sup>, Irena ŠABARIĆ<sup>1</sup>, Franka KARIN<sup>1\*</sup>

<sup>1</sup>University of Zagreb Faculty of Textile Technology, Prilaz baruna Filipovića 28a, 10000 Zagreb, Croatia, \*email: franka.karin@ttf.hr

---

## ABSTRACT

*Kindergarten teacher's work clothes are specific. In the introduction, the term "uniform" is described as a form of clothing with a particular purpose and codified rules. A uniform as a form of work clothes has to be adjusted depending on the profession it has been made for. The design, while taking into consideration the needs and demands of the profession, adds appeal and respects visual identity. The aim of this research is customized work clothes which set up and invoke communication between teachers and children. Unconventional design creates an interaction of educational nature. Functionality and innovation in kindergarten work clothes design are helping children communicate with teachers and motivate them to study more. The result of this research is a collection of customized uniforms created in collaboration with kindergarten teachers after the research.*

## KEYWORDS

*Customized work clothes, design, colour, functionality, visual identity*

---

## INTRODUCTION

The rules on work clothing dictate requirements that must be met in accordance with the type of activity. The role of the rulebook is safety and security at work. They are systematically upgraded and must meet the working conditions. In addition to protection, work clothes must also meet other essential features such as functionality, should not restrain movement during work, should have simple maintenance, further quality of the fabric is expected to wear resistance and longer life expectancy. Most attention, when referring to the rules of work clothing, is given to the protection specified as a synonym for working clothes according to Croatian norm HRN F.G1.301. According to the norm, it is necessary to meet the quality standards of the exact requirements of the textile from which the work cloth is made. Mentioned conditions must be proportional to each segment. The ultimate result is the synergies of prescribed conditions that represent a particular activity without which a member of a profession cannot achieve communication and interaction [1]. For some occupations, there aren't specific rules. Common to each type of activity is a protection of the body from the influence of the environment.

The theme of this paper is work cloth as a kind of protective clothing for kindergarten teachers. The role of this work cloth is to protect the upper body. Because of the minimal requirements, innovation in design and development of ideas on personalized workstations were enabled. Apart from



the shift in design where new forms, colours and patterns are explored, the purpose of this approach is to establish communication between children and educators. The aim is to encourage interaction between children and teachers, and the goal was learning through shapes and colours of the work clothes.

## **THE CONCEPT OF UNIFORMS AS WORKING CLOTHES AND ITS COMMUNICATION**

Uniform has its social importance and its role has not diminished over the years. Work cloth marks a hierarchy of workers in certain industries. Rules are necessary and useful for social relations and productivity in work. The term uniform comes from the German word "uniform". The origin of the French word is "*uniforme*" and the Latin name is "*uniformis*" meaning - uniform [2].

The word uniform, in Croatian literature, is defined as a garment subject strictly prescribed by the rules. The rules apply to uniforms and uniforms design for a particular activity. It is precisely prescribed the type of fabric that is most suitable for a particular working environment, just as the quality characteristics that it must meet. Functionality should not be neglected, it is extremely important that the work cloth is comfortable and does not hurt the wearer. The role of uniforms is to show the affiliation of an official's occupation especially in situations where it has to distinguish it from other activities [3].

### **General requirements for working clothes**

Ergonomics and ergonomic harmony with anthropometric conditions ensure the functionality of protective work cloth. The design is one of the main elements responsible for freedom of movement in work cloth and one of the most important factors for body protection, which work clothes must meet in accordance with EN 240: 2003, "Protective clothing, general requirements. It is strictly stipulated and defined that protective clothing is worn over or replacing private clothing. In both cases, it must provide protection against one or more hazards that may occur in the workplace. Model and cut are not the only parameters that ensure the protection while wearing work clothes. The material, its quality, strength, wear resistance, easy maintenance, wearing comfort and all other fabrics qualities, play a major role in meeting needed requirements of the work clothes[1].

Workers protection conditions must fulfil workers safety standards. They should be consistent with the performed activity in the work environment and are defined by norms. Norms are a positive way to discipline and enforce prescribed rules in society.

There is a "List of Croatian Standards for Personal Protective Clothing". The standard accepted and used in the Republic of Croatia is the norm HRN EN 340: 2004, its name is "Protective clothing - General requirements (EN 340: 2003)" and the basic document for the application of protective clothing is Council Directive 89/686 / EEC. [4]. It is stipulated that the norm cannot be used alone, but

always in combination with other norms. In order for the protective work clothes to fulfil its function, characteristics that depend on each other must be obtained. In accordance with the above-mentioned norms, the first of the characteristics is that the clothing must be universal for both sexes, which is aligned with the construction and realization of the model in more garment sizes. Ergonomics is a segment without which comfort of wearing and comfort during working cannot be achieved and is associated with design. The designer must anticipate the advantages and disadvantages of the garment item and incorporate prescribed characteristics for a particular occupation [1].

Basic health and ergonomic requirements are coming from European Directive 89/686/EEZ and their importance shouldn't be neglected. The basic health and ergonomic requirements of European Directive are design, comfort, the durability of materials ageing [1].

In the continuation of the paper, we will show the research on the personalization of work clothes of teachers in kindergartens. We'll describe the importance of communicating through clothing in which the main role stands for design and colour providing the interaction of children and teachers necessary for the developmental and educational process.

### **Communication of the work clothes of teachers in kindergartens**

People interact with each other in order to get the information they need for different purposes and for a variety of other reasons, such as giving a good impression to the other person they communicate with. The result of communication can be a deliberate effect when the goal of communication is achieved. If the result of communication is not understood in an expected way, then it has unintended effects. Communication requires at least two people who interfere with each other consciously or unconsciously to react in a verbal or nonverbal relationship and achieve a common meaning.

Usually, the communication is mutual, and, often, affected by communicational tools: media, speechless and interlocutors non-verbal communication. If the communicator did not accomplish the original goal, communication has nevertheless occurred regardless of the negative connotation [5]. Communication is divided into verbal and nonverbal. Verbal is expressed by speaking. Thoughts are transmitted to words, but messages are transmitted through gestures that are visualized, followed by reactions. It is subjectively perceived after its perception. Observation and experience of a subject can be learned [4]. An example is children whose first perception of the subject is two-dimensional, then three-dimensional, then a new vision and experience emerge that is affected by the concept of sensibility [6].

Nonverbal communication can be intentional or unintentional. Its goal is to express emotions, to emphasize attitudes and to encourage verbal communication [5].

The relationship between children and teachers affects the development of children in general and their mental maturation. Especially working clothes develop children's creativity, stimulate imagination, and inspire design-based education. For kindergarten's teacher working clothes, colours that have a psychological impact are important and their meaning develops certain emotions and human features.

#### *Impact of colour on emotions and behaviour*

Colours are unconsciously affecting people. According to research, the experience and perception of colour induce reactions in the human body and act on the psychological condition. Each colour has its meaning and causes a psychological effect on the mental and emotional field. According to Goethe's theory, colours in a man produce a moral effect and develop emotions that shape a person's character and define its behaviour. On the other hand, the psychologist's thesis is the current and short-term influence of colour. Regardless of the two different directions, the perception of colour in a psychological sense mentally develops the person. Colour is the driver of new ideas because it affects the development of creativity. Some of the colours calm down and overcome stressful situations, enhance concentration, self-confidence and balance emotions [7].

#### *Impact of colour psychology on a child*

In the development of the child part of the convention or cognitive process is to learn how to perceive and experience the colour even though the spectrum of colours is in the eye of the child since birth. A child must develop the ability to recognize colours and shapes and to name them after the knowledge during the visualization process [8]. Vision in a child develops in its first year of life when visual receptors recognize black and white colour. After the fourth month of the child's age, the sensation of the basic colour is developed. Up to the age of 18 months, a child learns generally to discern colours, notice the similarities and differences between them, the differences between the size of the object being experienced and the difference in shape and texture. Different colours, their meaning and interaction affect the mood, emotion and behaviour of children differently [9].

Colour naming is part of the child's development and takes place through several levels: pairing, showing and naming colours. Colour learning begins by sorting and pairing of objects that are of equal colour and begins with a basic colour, after the child has adopted the knowledge of the first colour, turns attention to the other. The next step is to notice the colour in the environment. Learning in this way is best done in the form of a game e.g. while shopping in a child's store through the play shows all the objects in a particular colour or while driving a car the child shows all the vehicles in a certain colour. In this way, children develop security in the colour world. The last step is the systematics in pairing and recognizing items of the same colour. This is a prerequisite for the colour naming

process. A chronological age in which a child should be able to name basic colours is not defined. It is part of the cognitive (cognitive) development of a child. At the age of three, most children develop the ability to differentiate colours [10].

#### *Preschool child and colour*

In pre-school development, especially in the age when children do not have sufficiently developed verbalization and speech, the colour allows them to communicate with the environment in a simple, understandable way. For other communicational processes, they are not sufficiently developed and their subconscious is traversing the unknown things which create a feeling of insecurity. Chromotherapy is colour therapy by which children learn to perceive and recognize colours so that all their senses are included in learning. With multiple sensors, they quickly and efficiently overcome the task set in front of them. They develop thoughts, feelings, speech, and interaction with other people.

The colour the child chooses as his favourite, speaks a lot about his character and personality. It detects the mental and emotional state and spiritual development. Choosing a child's favourite colour should not be affected because then it will not develop an understanding of the inner world. Apart from the psychological aspects, the child's favourite colour speaks of a child's relationship to the environment, parents, peers in kindergarten and teachers. The colours that the child ranks first and second in his favourite colours represent the personality and current stage of development. The colours that are found in the last and last place represent the personalities that the child does not want to develop for some reason. These are the qualities that refrain from themselves. In this case, it is necessary to help the child to notice the colours that are not dear to him. It is necessary to establish which features are hidden behind the colour that does not attract it as well as the reason why it refuses them [8].

#### *Development and creativity in children*

"The child thinks with his hands". The child has the inborn consciousness and needs to explore everything around him. The tactile sensation is directly related to the environment that is being explored and in this way best adapts to new knowledge and is developing. The development of the child is individual and specific. They differ in the mode and intensity of the research, which links the differences in the interests and capabilities of the child. Discovering an unknown area that a child wants to explore, reveals by activating sensory stimuli and therefore needs to provide expression in its unique way.

It needs to be motivated to achieve independent results in the process of research, understanding and understanding of the environment. Great role in discovering the child's interests and the result and success of his actions are born by the educators. In kindergartens, they encourage

them to express themselves freely in creative spaces full of colours, textures, sounds and smells. Their purpose is to awaken more sensory stimuli that gain access to unknown information. It needs to be developed so children can gain more levels of experience in their experience of a new environment [11].

## **EXPERIMENTAL**

According to the rules and norms that are prescribed for the service of working clothes, the condition that must be met by the kindergarten teacher's work in kindergartens is to wear as the upper garment over private clothing. There are no specific requirements for a design solution as far as the model is concerned, there is no requirement for the type of material to be made, as well as the colour spectrum. Given that it is necessary to meet one legally defined characteristic, it provides an innovative approach to the design of work uniforms of this type. Personalized work clothes for teachers are selected. Research into designs and forms of workpieces, colours, textile patterns and applications will present a collection of workstations and explain how they establish communication between children and teachers.

Communication is every kind of interaction that manifests in different ways. Some examples are eye contact or other types of physical contacts, various gestures, verbal communication, etc. Communication is a major feature in all types of occupations. Its role is great and is a key to business success. The meaning of the word communication is to do something general or common, and its definition combines three main factors: content, form, and goal. Content and form combine to send information to a goal that can be one person and then it is about interpersonal communication. The target may be groups of people, society, organizational groups, in short, some other entities [5].

### **Interview with teachers**

The interview is conducted according to the seven stages of a research interview. The purpose of the applied method, which includes specific approaches and testing techniques, is the discussion and understanding of the theme of work on personalized work uniforms and the review of the respondents from their own perspective. This approach enables survey researchers to obtain reliable facts based on the previously adopted knowledge of a particular topic being explored [12].

The interview was conducted interactively with the respondents after a certain amount of time had passed to see if the personalized approach to the work clothes design was successful. An interactive interview is a conversation between two or more people on a topic of mutual interest. Given that 12 teachers approached the interview, it could be defined as an interview for the target group. Such a type of conversation usually consists of 6 to 10 people led by the interview moderator. The moderator's role is to introduce discussion, encourage debate and express personal and conflicting

views of respondents. The goal of this method is to get information, opinions and attitudes from the personal perspective of the respondent. Interviews conducted on target groups are suitable for further research, as collective interaction can result in more spontaneous expressive and emotional attitudes.

Questions are designed to explore the meaning of concepts, their positions, and links to the topic to which the interview relates [12].

### **Design of personalized work clothes for teachers in kindergartens**

For the teachers in kindergartens work, clothes are indispensable. Their purpose and role are to protect the upper body from subjects which are present in working with children. Work clothes as a work uniform are mandatory but there is no rule on its appearance. Because of the simple and minimal conditions to be met, for the teachers work clothes, the idea for a new approach to design has developed. When working on a design, the two characteristics are retained, its simplicity and the necessity of the shape to cover the clothes under it. Other elements that make the design of personalized work cloth have been explored in detail. New approaches to cutting have been explored, resulting in unconventional forms where simplicity is maintained for functional markers. Work clothes for teachers in kindergartens are designed in "A" and "I" lines. These two shapes are important because of unobstructed movements. In the research, these two lines seemed to be the best option. These are confirmed by teachers in kindergartens. When establishing a satisfying form, the creative game continues with colour, patterns on fabrics and fashion accessories which purpose other than aesthetics, is interaction and communication between teachers and children. Simple and contemporary design besides the purpose of working clothes has the task of improving the development and education of children. A design solution wants to attract the child's attention and encourage motivation for learning and recognizing colours, letters, numbers, shapes [13].

The material must be of natural origin, resistant to high temperatures and must be stable when the paint is maintained. These requirements are met by Popelin, fine, pure or mixed cotton yarn, due to their density and fineness, and the finely structured surface of 100% pure cotton fabric [3]. If properly maintained the loss of strength with time is minimal and comfort during wear is satisfactory. Available in all colour spectra, pattern combinations and the like [14]. The colors are carefully selected based on the results achieved by interaction with children, mostly their favorite colors, colors that describe the character of children and act positively on their behavior. Samples as well as color were chosen according to a research that proved to be the favorite motifs for children who are related and tangible in everyday life, motifs that are familiar to them and surrounding them in their surroundings. The research found that there is no competition in designing work clothes for teachers with the approach like this. Specialized sales outlets for workwear do not sell personalized work clothes since

their adaptation to the rules, designs and requirements of the user takes time, therefore there is a potential for product quality reduction [13].



Figure 1. Creative game

According to the goals that include the characteristics necessary for work clothes in kindergartens, matched with design thinking and material, a creative game (Fig.1) created a collection of personalized work clothes for teachers. Three models were sorted from the collection, which was tailored to individual body measurements, a modelling procedure was performed and a prototype was created before the final realization. Once it has been established that the prototype completely

fulfilled the expectations of the user and after the correction of the cut, if necessary, the work clothes was realized in the material.

The material, colour and pattern are carefully selected and aligned with the model. Personalization of the work clothes is the result of research and collaboration with teachers who have expressed their needs and requirements that work clothes needed to satisfy, just as the colours, shapes and motives they prefer [13].

## RESULTS

Researching the influence of colour on children, the role of the teachers work clothes in kindergarten and the communication with the teachers resulted in the creation of 5 personalized work clothes models. The results are shown in figures 1 - 3.



Figure 2: Model of work clothes no. 1



Figure 3: Model of work clothes no. 2



## Reactions of children and educators after three months of working with children in personalized work clothes

After 3 months of work in personalized work clothes at the kindergarten Bedekovčina, for which clothes were made within this work, the teachers presented their experiences. A structured interview of 10 issues related to design, functionality and communication has been made. Questions were answered by 12 teachers. Ten teachers cast their opinions based on their own experience after 3 months of work in personalized work clothes. Two teachers cast their minds by observing colleagues working in personalized work clothes.

Interview questions and answers:

1. How do you like the approach of personalized work uniforms?

Teachers believe that the work clothes made in this way, with colours and playful patterns, give warmth and openness to children, which is extremely important in the period of adaptation of children to kindergarten. Personalized uniforms approach is a good idea because they provide an individualized approach, flexibility inside of their organization, and acceptance (people in uniform), which is one of the most important characteristics of their profession.

2. Do you think that this approach in the design of work uniforms should be carried out in the future for teachers in kindergartens?

They support the personalized approach to the design of the work clothes and feel that it should continue to be implemented in kindergartens in the future and predict that it will develop well because it is accepted among employees and children. Parents also react positively.

3. What are the advantages of work clothes in terms of functionality, comfort in wearing and maintaining?

The teachers rated the work clothes as very functional because they are protecting their personal clothes under it, comfortable to wear because of the natural materials they are made of, do not disturb everyday movements during working hours and are easy to maintain because they bear high temperatures during washing.

4. Do they have any deficiencies, if any, which ones?

Disadvantages after 3 months of wearing personalized work clothes were not observed.

5. How children react to personalized work clothes?

Personalized work clothes induced positive reactions in children. Given the fact that children are seeing changes in adults, they notice when the teacher is wearing or not wearing work clothes. Playful and creative work clothes encourage communication and leave a positive impression on the child and the teacher.

6. Does this kind of approach allow children to be educated (do children develop faster and easier to recognize colour, texture and shape ...)?

This approach in design encourages children's education from socio-emotional development in which communication, emotions and emotional reactions, and the recognition of colours and shapes belong. The cognitive development of a child is promoted, namely recognizing and naming colours, geometric characters, fairy-tale characters, and developing touch sensations.

7. What kind of communication and interaction the teachers and children create with this type of work clothes?

The teachers highlighted positive results in communication and interaction with children. As an example, working clothes of this type helps out to introverted children who make easier communication through it.

8. And how did the personalized work clothes improve the quality of work in the kindergarten?

Working clothes does not condition the quality of the work, it is a part of the person who wears it. The teacher's interaction with the child through its observing of work clothes detects what a child likes and by that can make easier its adjustment or staying in kindergarten by planning activities based on some motives on work clothes.

9. What impresses you most in the work clothes design and why?

In the design of the work clothes, the teachers were impressed by its visual identity. The combination of colours and shapes encourages a good mood in children. Children feel more relaxed and have more confidence with the teacher than in monotonous and same work uniforms.

10. What are your suggestions to improve this approach to work uniforms and why?

They support and recommend the approach to the design of the work clothes in kindergartens supports and to all kindergartens, teacher, and principals in order to know and understand the quality of work clothes personalization. They recommend that such a questionnaire be conducted among children. In this way, they would find their opinion, which they prefer, a variant when all teachers have the same work clothes or when they have different. Children will certainly provide useful guidance for further development.



Figure 3: Teachers in Bedekovčina kindergarten in personalized work clothes

## CONCLUSIONS

There is no strict rule for the kindergarten teacher's work clothes, which gives the designer more freedom for ideas. In the design of work clothes colours and patterns have an important role in encouraging a child to learn, differentiate, creativity, verbal communication, affect emotions, mood, and behaviour. Everything from the child's environment allows learning, which is why work clothes is a good example of overcoming everyday activities. It also helps children and adults overcome stress and shock, feel depressed, relieve anger, rage and sorrow, and provide mental security and inner balance. Personalized work clothes in kindergarten increase production costs, but positive responses generated by this approach and proven after working with children show that this approach should not be neglected. The research was conducted in a kindergarten where 12 teachers were employed. All the reactions of children, parents, and teachers were positive, which certainly shows the need for such an approach to work clothes making. Among other things, the personality of the teachers shows in everyday dressing, so this approach is one of the important segments in the educational system. Aesthetically and functionally designed uniforms send a positive message and contribute to the quality of working with children. The positive reactions of children, parents and teachers show that such an approach is desirable and opens up opportunities for further research on the theme of personalized work clothes for teachers in kindergarten.

## REFERENCES

- [1] Pejnović, N. Osobna zaštitna oprema za zaštitu tijela. Sigurnost. 2015. 57 (3):229-242
- [2] Hrvatski leksikon. Uniforma. Available from: <http://www.hrleksikon.info/definicija/uniforma.html>

- [3] Hrvatska enciklopedija Leksikografskog zavoda Miroslav Krleža. Odjeća. Available from: <http://www.enciklopedija.hr/natuknica.aspx?id=63206>
- [4] Narodne novine. Popis hrvatskih normi za osobnu zaštitnu opremu. Available from: [http://narodne-novine.nn.hr/clanci/sluzbeni/full/2009\\_09\\_110\\_2825.html](http://narodne-novine.nn.hr/clanci/sluzbeni/full/2009_09_110_2825.html)
- [5] Krešić, V. Komunikacija u sestrinstvu - međuljudski odnosi zdravstvenih djelatnika. Sestrinski glasnik. 2013. SG/NJ 18:41-43. Available from: <https://doi.org/10.11608/sgnj.2013.18.010>
- [6] Pražić, B. Crtež i slika u psihijatriji. Zagreb. Naprijed; 1987.
- [7] Subašić, J. Psihologija boja-Kako boje utječu na raspoloženje, emocije i ponašanje. Impuls portal. 2017. Available from: <http://impulsportal.net/index.php/kultura/alter/6999-psihologija-boja-kako-boje-utjecu-na-raspolozenje-emocije-i-ponasanje>
- [8] Zjakić, I, Milković, M. Psihologija boja. Varaždin. Veleučilište u Varaždinu; 2010.
- [9] Lovrić-Cindrić, D. Kako razviti emocionalnu inteligenciju djeteta. Zagreb. Mozaik knjiga; 2015.
- [10] Starčević Perica, M. Kako djeca uče boje? Martinin blog. 2018. Available from: <http://martininblog.hr/kako-djeca-uče-boje/>
- [11] Cvetković Lay, J, Sekulić Majurec, A. Darovito je, što ću s njim? Zagreb. Alinea; 2008.
- [12] Sveden Brinkmann, Steinar Kvale. Interviews, Learning the Craft of Qualitative Research Interviewing. Third Edition. SAGE Publication; 2015.
- [13] Jakuš, S. Projektiranje kolekcije radne odjeće za odgajateljice u vrtiću. Zagreb. Sveučilište u Zagrebu Tekstilno-tehnološki fakultet; 2018.
- [14] Čunko, R. Kvaliteta tekstilnih proizvoda. Zagreb. Zrinski d.d; 2009.

# MODELLING A COLLECTION OF WOMEN DRESSES INSPIRED BY THE ANOMALIES IN HUMAN BEHAVIOUR

**Nikolija BARETIĆ<sup>1</sup>, Ksenija DOLEŽAL<sup>1\*</sup>**

<sup>1</sup>University of Zagreb Faculty of Textile Technology, Prilaz baruna Filipovića 28a, 10000 Zagreb, Croatia, \*email: ksenija.dolezal@ttf.hr

---

## **ABSTRACT**

*In the world of endless ideas of individuals and designers, it is necessary to explore new possibilities in their realization. This article, in fact, finds inspiration deeper in human existence. It is based on anomalies in human behaviour, and through the creative process it shows how they can manifest themselves in shaping the collection. The article covers three, statistically, most common forms of anomalies or human behaviour disorders, and through discussion it indicates that they shape the form of the model in the collection of women dresses.*

## **KEYWORDS**

*Clothing design, clothing modelling, women dresses*

---

## **INTRODUCTION**

Today fashion is subject to rapid changes, which are marked by trends from season to season. Designers in searching for new ideas to develop collections sometimes are driven by aspects of life, positive or negative, which can be easily applied onto clothes, throughout form or content of clothing. Mentioned reflections have resulted in development of a collection of women's dresses. The inspiration for collection modelling is based on changes in human behaviour, which is not in accordance with expected and ingrained behaviour patterns. Following the mentioned anomalies in behaviour and their features, the idea for the realisation of collection containing three models was created.

### **Anomalies in human behaviour**

Personality disorders are pervading, inflexible and constant forms of behaviour that cause significant suffering or functional disorder. Personality consists of ways of thinking, understanding, reactions and associating, which over time get relatively stable in different situations [1]. Personality is noticeable from late adolescence i.e. early adult age, and although it defines a person over a longer period of life, some behavioural characteristics get less conspicuous with age, and some can be changed. Personality disorders occur when these characteristics become maladaptive, to such a level that it interferes with human functioning on daily basis.

### *Bipolar disorder*

Bipolar disorder is characterized by alternation of mania and depression at certain time periods. Compared to those periods, but also to other factors, such as the intensity of these phases, bipolar disorder is divided into several types. Bipolar affective disorder is an endogenous mental illness in which the episodes of mania and depression alternate. It belongs to heavy endogenous psychosis. The phase shift is not defined, so it comes to shorter manic and long depressive periods, or vice versa. It does not damage the patient's personality, and between manic and depressive cycles, the patient acts healthy and balanced [2].



Figure 1. Visual representation of mood swings in persons suffering from BAP [3]

### *Obsessive-compulsive disorder*

This type of disorder is characterized by unreasonable thoughts and fears (obsessions), which impel the person to repeated forcible or compulsive behaviour. People with obsessive-compulsive disorder feel the need for compulsory actions with an effort to ease their stressful emotions. Having an obsessive compulsive disorder, a person may and not be aware that the obsession is unreasonable. Compulsiveness represents the urge to perform and to repeat actions that are perceived as internal constraint [4]. Persons with obsessive compulsive disorder often have sudden, short, sporadic movements (ticks), and also symptoms as persistent unstable thoughts or mental images may occur, that cause pain and anxiety.

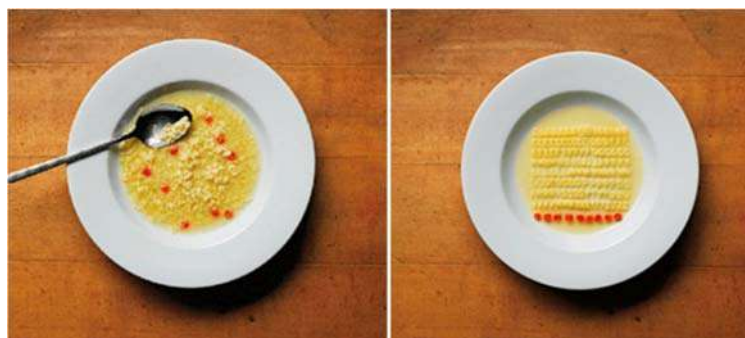

Figure 2. Visual representation of obsessive-compulsive disorder symptoms [5]

Compulsive behaviour involves recurring behaviour that is triggered by obsession or instincts. This recurring behaviour has the purpose of reducing the anxiety associated with obsession or preventing bad things that might happen. As consequence of obsession, one can notice verification of actions, resulting from fear of some kind of damage (fire, flood, burglary, etc.), contamination or constant need for cleaning and washing [4].

#### *Post-traumatic stress disorder*

Post-traumatic stress disorder is a psychological consequence of exposure to stressful experiences that include death threat, serious physical injuries, and threat to persons mental or physical integrity. In the focus of trauma is the memory of the main stressful event (such as the image and sound of gunfire, screams or instant silence, knife stab, mine explosion, wounding, punch, sounds of an aircraft or a siren). Violent acts have worse consequences for victims from natural disasters, since victims of violence or violent events have the feeling that they were deliberately chosen as an abuse target. For victims of abuse the social world becomes a dangerous place where people from the surrounding represent a security threat. In victim's memory, a pattern of human cruelty is engraved, because of which the attacked person looks with fear at everything that resembles the attack, that has caused the trauma [6,7].

## **EXPERIMENTAL**

In this part of the article, three dress models, of which the collection consists, are made by modelling procedures on the basic women's dress pattern [8].

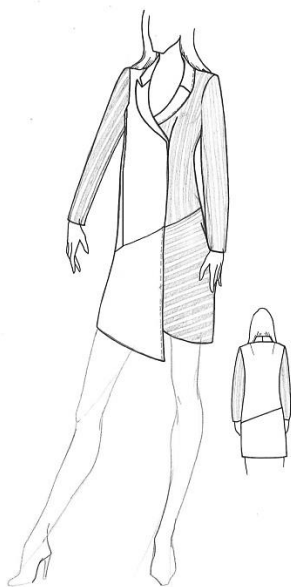

Figure 3. First model



Figure 4. Second model

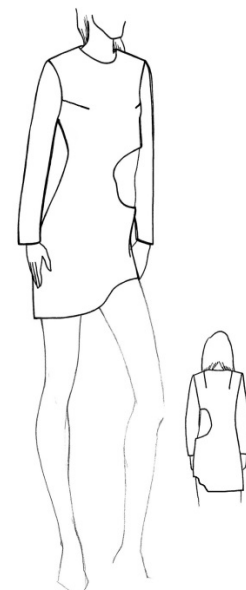

Figure 5. Third model

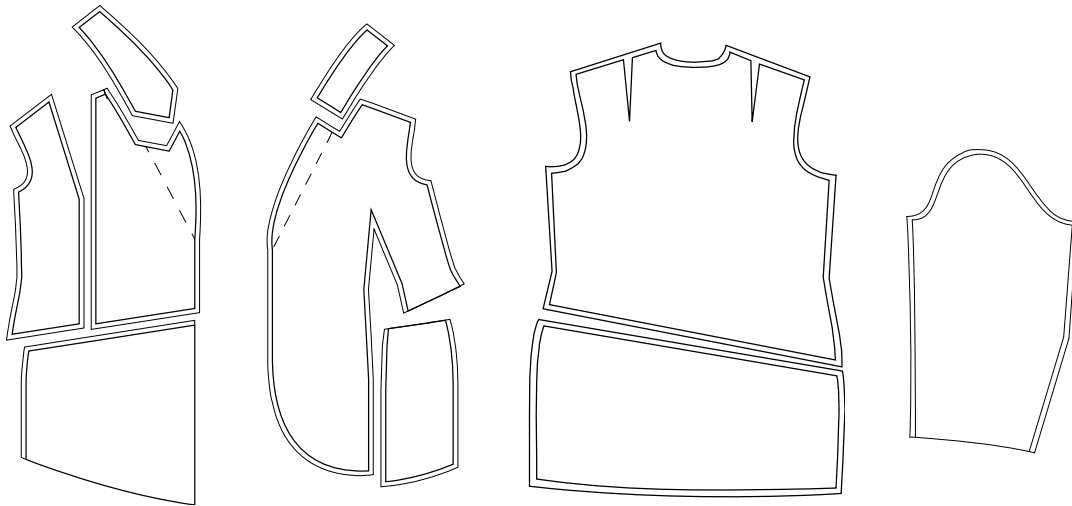

Figure 6. Modelling a first model

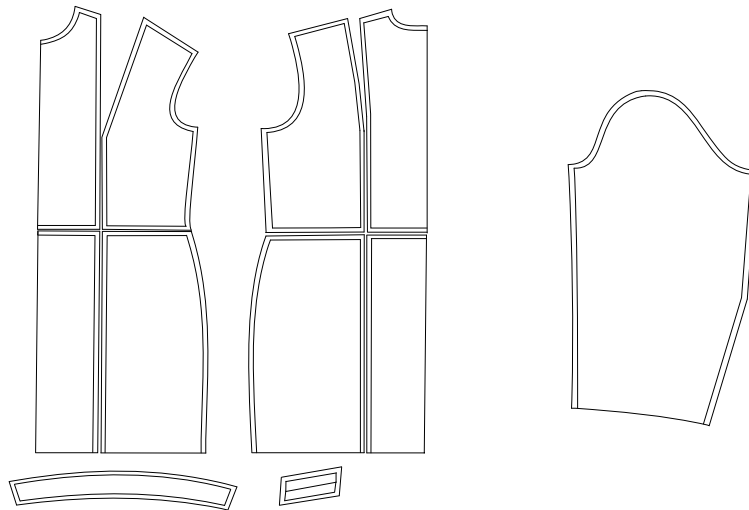

Figure 7. Modelling a second model

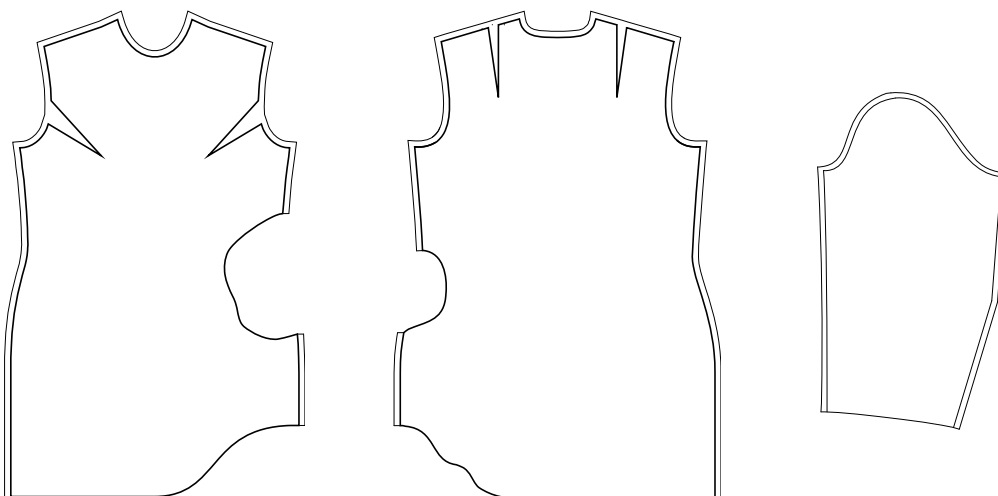

Figure 8. Modelling a third model



## DISCUSSIONS

Using modelling procedures, a collection of three models was created, inspired by changes in human behaviour. The specificity of the first model is asymmetry in form; the left and right front parts are opposed to each other. Precisely through this duality of form, the first link to behaviour of people suffering from bipolar disorder appears. So, a certain disharmony, is what this disorder characterises - as here is the case with pattern parts. Namely the bipolar disorder is manifested in this model primarily throughout the form.

In the second model throughout the form the characteristics of behaviour anomaly is shaped. Inspiration is based on cognition about obsessive-compulsive disorder. The specificity of this disorder is that in the case of an ill person, certain, not necessarily inappropriate, action is repeated on a daily basis countless times, based on what can be concluded it is about aforementioned disorder. This is manifested on the pattern of the second model by repetition of certain elements such as stand-up collar, pocket lids, pattern symmetry and more pattern parts. The higher number of repetition of pattern parts implies repetition of actions or compulsive behaviour as part of the anomaly.

The third model is elaborated in a different way, compared to the previous two. It was made by reduction of the second model pattern. Deprived of a multitude of pattern parts in appearance, it is based on the content, instead on realization through the form. The idea is that this garment of simpler appearance and without patterns, with a flat surface, intended for dressing for people with post-traumatic stress disorder. A person, who has experienced in life any form of trauma, can use the dress as a canvas and in this way express her emotions on the fabric. In this case, the traumatized individual adds the visual content to this model, which can be considered as a certain type of self-help.

Thereby the traumatized person becomes a designer and may change the appearance of the model at his own discretion, if she wishes so. By removing the material to create a hole, the ill person negates the suffered trauma and turns to an alternative that allows her to express herself creatively on the remained part of this dress model. The same hole represents the trauma, and may be larger or smaller with variations in shape.

## CONCLUSIONS

The collection of dresses inspired by changes in human behaviour was made as the result of short personal research and unification of problems that today's society is facing. In the centre of both is the man and his relationship to himself and to the environment in which he exists. Human behaviour is relative and it is marked by changes that are not necessarily positive, and is influenced by a number of external and internal factors. There are three such changes, i.e. behavioural disorders, transformed into the form of dress models.

## REFERENCES

- [1] MSD priručnik dijagnostike i terapije: Poremećaji osobnosti [Internet]. [Cited 2018 Aug 21] Available from: <http://www.msd-prirucnici.placebo.hr/msd-prirucnik/psihijatrija/poremecaji-osobnosti>
- [2] Thomas D. Meyer: Bipolarni poremećaj, Naklada Slap, ISBN: 978-953-191-357-7, 2008.
- [3] Psiholoskosavetovanje. rs - Razgovori i terapije [Internet]. [Cited 2018 Sep 10] Available from: <https://www.psiholoskosavetovanje.rs/bipolarni-poremecaj/>
- [4] Opsesivno-kompulzivni poremećaj – Wikipedija [Internet]. [Cited 2018 Sep 15] Available from: [https://hr.wikipedia.org/wiki/Opsesivno-kompulzivni\\_poreme%C4%87aj](https://hr.wikipedia.org/wiki/Opsesivno-kompulzivni_poreme%C4%87aj)
- [5] Opsesivno-kompulzivni poremećaj, Divithana [Internet]. [Cited 2018 Sep 25] Available from: <http://divithana.com/lifestyle/moda-i-zdravlje/psihologija/opsesivno-kompulzivni-poremecaj/>
- [6] Klain E., Gregurek R.: Posttraumatski stresni poremećaj, Medicinska naklada, 2001.
- [7] Posttraumatski stresni poremećaj – Wikipedija [Internet]. [Cited 2018 Sep 25] Available from: [https://hr.wikipedia.org/wiki/Posttraumatski\\_stresni\\_poreme%C4%87aj](https://hr.wikipedia.org/wiki/Posttraumatski_stresni_poreme%C4%87aj)
- [8] Ujević D., Rogale D., Hrastinski M.: Tehnike konstruiranja i modeliranja odjeće – drugo dopunjeno i prošireno izdanje, Tekstilno-tehnološki fakultet, Zrinski d.d., Čakovec, 2004.

**Book of Proceedings  
of the  
12<sup>th</sup> International Scientific-Professional Symposium  
Textile Science & Economy**

**January 23<sup>rd</sup> to 24<sup>th</sup>, 2019  
Zagreb, Croatia**

**ISSN 2584 - 6450**